

- ※ DC TYPE WITH SHORT CIRCUIT PROTECTION AND POLARITY REVERSED PROTECTION
 直流型都附有短路保護和極性反接保護迴路
- ※ AC TYPE WITH SURGE ABSORBING CIRCUIT MAY AVOID SURGE DAMAGED
 交流型都附有突波吸收迴路可避免突波破壞
- ※ HIGH SOLID COMPACT STRUCTURE IP-67 SUITED TO BE APPLIED IN THE POOR CIRCUMSTANCE
 堅固結構- IP67- 適用各種環境
- ※ ALL MODELS WITH OPERATING LED, EASY TO ADJUSTED
 全機種附動作指示燈便於安裝調整

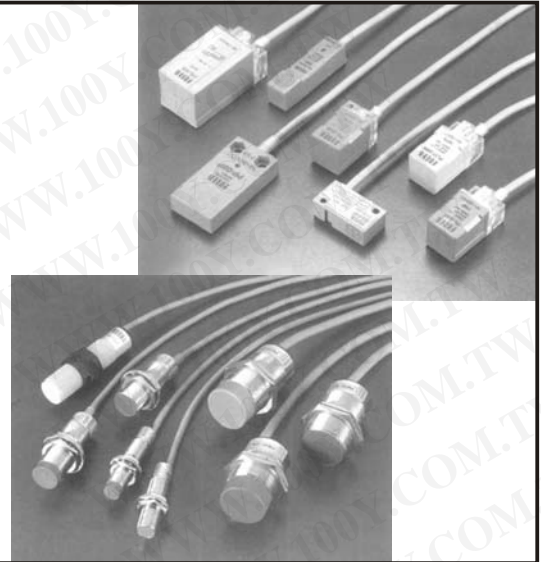

Guiding of Model 型號索引

TUBULAR TYPE

Ex. PM - 12 04 - N B - S - M12
 ① ② ③ ④ ⑤ ⑥ ⑦

- 1> TYPE 型式
 PM= SCREW TYPE 螺絲型
- 2> OUTLINE DIAMETER 外徑
 08=M8x1.0 18=M18x1.0
 12=M12x1.0 30=M30x1.5
- 3> SENSING DISTANCE 檢測距離
 02=2.0mm 10=10. mm
 05=5.0 mm 15=15.0mm
- 4> OUTPUT METHOD 輸出方式
 N=NPN P=PNP
 S=SCR
- 5> OUTPUT STATUS 輸出狀態
 NON= NO TYPE
 B= NC TYPE B= NC TYPE
- 6> LENGTH OF BODY 本體長度
 NON= STANDARD TYPE
 S= SHORT TYPE
- 7> CONNECTING METHOD 接線方式
 NON= LEAD WIRE TYPE
 M12= M12 CONNECTOR TYPE
 PG= M8 LEAD WIRE CONNECTOR TYPE

SQUARE TYPE

Ex. LS - 04 N B - V - PG
 ① ② ③ ④ ⑤ ⑥

- 1> TYPE 型式
 PS=SQUARE TYPE PP=PLATE TYP
 PL=LONG TYPE BS=MICROTYPE
- 2> SENSING DISTANCE 檢測距離
 04= 4.0 mm 10= 10.0mm
 05= 5.0 mm 15= 15.0 mm
- 3> OUTPUT METHOD 輸出方式
 N= NPN P= PNP
- 4> OUTPUT STATUS 輸出狀態
 NON= NO TYPE
 B= NC TYPE B= NC TYPE
- 5> DIRECTION OF SENSING
 V= VERTICAL TYPE 垂直式
 NON= HORIZONTAL TYPE 水平式
- 6> CONNECTION METHOD 接線方式
 NON= LEAD WIRE TYPE
 PG= M8 LEAD WIRE CONNECTOR TYPE

**NOTE : THE B<NC> TYPE HAVE NO STOCK
 MAYBE, ACCEPTED ORDER TO MANUFACTURE**

Output Circuit & Connection Diagram

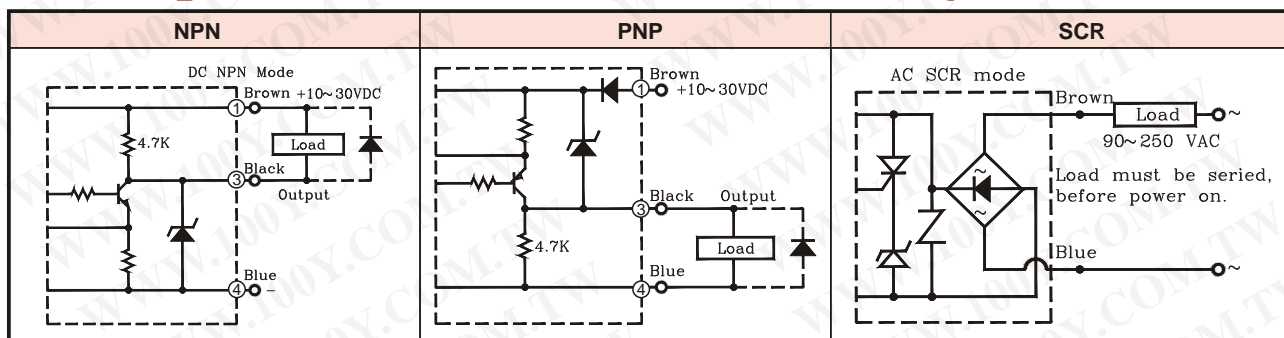

General Data

Specification	DC Type	AC Type
Operating Voltage	10~30 VDC	90~250VAC
Power Ripple	< 20% of Peak to Peak	50/60Hz
Output Current	150mA max.	100mA max.
Current Consumption	< 10mA	< 2mA
Residual Voltage	< 0.1V	
Leakage Current	< 0.8mA	< 4.0mA
Hysteresis	<10% of Sensing Distance	
Thermal Drift	< 10 μ m/ C	
Voltage Drift	< 1 μ m/V	
Protection Circuit	Short Circuit & Polarity Reversed Protection	Surge Protection Circuit
Operating Temp./Hum.	-20°C~+80°C ; 35%~95% RH	
Protection Class	IP-67	
Wiring Method	3 Cores / 4.2 ϕ X 2m	2 Cores / 4.2 ϕ X 2m
Color of Sensing Face	NPN : Red ;PNP ;Green	Blue

Application Hints

When using a switching regulator , please be sure to ground the FG (Frame Ground) and G (Ground) terminal , If failure to do so , if may resulting malfunction of the sensor for the noise of the switching regulator. The ripple of the DC power supply is required less than 20% to avoid resulting malfunction of the sensor.

■ Square Type < Plastic Housing >

Outline Dimension	Model	Output Method	Sensing Distance	Mounting Method	Sensing Direction	Operating Voltage	Response Frequency
	LS-04N-V	NPN	4.0mm	Non-Flushed	Vertical	10 ~ 30 VDC	2KHZ
	LS-04P-V	PNP			Horizontal		
	LS-04N	NPN					
	LS-04P	PNP					
	SP-05N	NPN	5.0mm	Non-Flushed	Vertical	10 ~ 30 VDC	800HZ
	SP-05P	PNP					
	BS-02N	NPN	2.0mm	Flushed	Vertical	10 ~ 30 VDC	2KHZ
	BS-02P	PNP	4.0mm	Non-Flushed			
	BS-04N	NPN					
	BS-04P	PNP					
	PP-05N	NPN	5.0mm	Flushed	Vertical	10 ~ 30 VDC	800HZ
	PP-05P	PNP	8.0mm	Non-Flushed			
	PP-08N	NPN					
	PP-08P	PNP					
	PS-04N-V	NPN	4.0mm	Non-Flushed	Vertical	10 ~ 30 VDC	2KHZ
	PS-04P-V	PNP	Horizontal				
	PS-04N	NPN					
	PS-04P	PNP					
	PS-05N	NPN	5.0mm	Flushed	Horizontal	10 ~ 30 VDC	800HZ
	PS-05P	PNP	8.0mm	Non-Flushed			
	PS-08N	NPN					
	PS-08P	PNP					
	PL-05N	NPN	5.0mm	Flushed	Horizontal	10 ~ 30 VDC	800HZ
	PL-05P	PNP	8.0mm	Non-Flushed			
	PL-08N	NPN					
	PL-08P	PNP					
	PS-05S	SCR	5.0mm	Flushed	Horizontal	90 ~ 250 VAC	20HZ
	PS-08S	SCR	8.0mm	Non-Flushed			
	PS-10N	NPN	10.0mm	Flushed	Horizontal	10 ~ 30 VDC	500HZ
	PS-10P	PNP					
	PS-15N	NPN	15.0mm	Non-Flushed	Horizontal	90 ~ 250 VAC	20HZ
	PS-15P	PNP					
	PS-10S	SCR	10.0mm	Flushed			
	PS-15S	SCR	15.0mm	Non-Flushed			

M8/M12 Tubular Type

Outline Dimension	Model	Output Status	Output Method	Operating Voltage	Sensing Direction	Response Frequency	Mounting Method
	PM08-01N	NO	NPN	10 ~ 30 VDC	1.0mm	2.5KHZ	Flushed
	PM08-01NB	NC					
	PM08-01P	NO	PNP				
	PM08-01PB	NC					
	PM08-02N	NO	NPN	10 ~ 30 VDC	2.0mm	2.5KHZ	Non-Flushed
	PM08-02NB	NC					
	PM08-02P	NO	PNP				
	PM08-02PB	NC					
	PM12-02N-S	NO	NPN	10 ~ 30 VDC	2.0mm	2.5KHZ	Flushed
	PM12-02NB-S	NC					
	PM12-02P-S	NO	PNP				
	PM12-02PB-S	NC					
	PM12-04N-S	NO	NPN	10 ~ 30 VDC	4.0mm	2.5KHZ	Non-Flushed
	PM12-04NB-S	NC					
	PM12-04P-S	NO	PNP				
	PM12-04PB-S	NC					
	PM12-02N	NO	NPN	10 ~ 30 VDC	2.0mm	2.5KHZ	Flushed
	PM12-02NB	NC					
	PM12-02P	NO	PNP				
	PM12-02PB	NC					
	PM12-04N	NO	NPN	10 ~ 30 VDC	4.0mm	2.5KHZ	Non-Flushed
	PM12-04NB	NC					
	PM12-04P	NO	PNP				
	PM12-04PB	NC					
	PM12-02S	NO	SCR	90 ~ 250 VAC	2.0mm	20HZ	Flushed
	PM12-02SB	NC					
	PM12-04S	NO	SCR	90 ~ 250 VAC	4.0mm	20HZ	Non-Flushed
	PM12-04SB	NC					
	PM12-02N-M12	NO	NPN	10 ~ 30 VDC	2.0mm	2.5KHZ	Flushed
	PM12-02NB-M12	NC					
	PM12-02P-M12	NO	PNP				
	PM12-02PB-M12	NC					
	PM12-04N-M12	NO	NPN	10 ~ 30 VDC	4.0mm	2.5KHZ	Non-Flushed
	PM12-04NB-M12	NC					
	PM12-04P-M12	NO	PNP				
	PM12-04PB-M12	NC					

PM18 series

INDUCTIVE PROXIMITY SENSOR

CE

M18 Tubular Type

Outline Dimension	Model	Output Status	Output Method	Operating Voltage	Sensing Direction	Response Frequency	Mounting Method
	PM18-05N-S	NO	NPN	10 ~ 30 VDC	5.0mm	800HZ	Flushed
	PM18-05NB-S	NC					
	PM18-05P-S	NO	PNP				
	PM18-05PB-S	NC					
	PM18-08N-S	NO	NPN	10 ~ 30 VDC	8.0mm	800HZ	Non-Flushed
	PM18-08NB-S	NC					
	PM18-08P-S	NO	PNP				
	PM18-08PB-S	NC					
	PM18-05N	NO	NPN	10 ~ 30 VDC	5.0mm	800HZ	Flushed
	PM18-05NB	NC					
	PM18-05P	NO	PNP				
	PM18-05PB	NC					
	PM18-08N	NO	NPN	10 ~ 30 VDC	8.0mm	800HZ	Non-Flushed
	PM18-08NB	NC					
	PM18-08P	NO	PNP				
	PM18-08PB	NC					
<p>Polymid Housing</p>	PM18-08N-P	NO	NPN	10 ~ 30 VDC	8.0mm	800HZ	Non-Flushed
	PM18-08NB-P	NC					
	PM18-08P-P	NO	PNP				
	PM18-08PB-P	NC					
	PM18-08S-P	NO	SCR				
	PM18-08SB-P	NC					
	PM18-05S	NO	SCR	90 ~ 250 VAC	5.0mm	20HZ	Flushed
	PM18-05SB	NC					
	PM18-08S	NO	SCR	90 ~ 250 VAC	8.0mm	20HZ	Non-Flushed
	PM18-08SB	NC					
	PM18-05N-M12	NO	NPN	10 ~ 30 VDC	5.0mm	800HZ	Flushed
	PM18-05NB-M12	NC					
	PM18-05P-M12	NO	PNP				
	PM18-05PB-M12	NC					
	PM18-08N-M12	NO	NPN	10 ~ 30 VDC	8.0mm	800HZ	Non-Flushed
	PM18-08NB-M12	NC					
	PM18-08P-M12	NO	PNP				
	PM18-08PB-M12	NC					

M30 Tubular Type

Outline Dimension	Model	Output Status	Output Method	Operating Voltage	Sensing Direction	Response Frequency	Mounting Method
	PM30-10N-S	NO	NPN	10 ~ 30 VDC	10.0mm	500HZ	Flushed
	PM30-10NB-S	NC					
	PM30-10P-S	NO	PNP				
	PM30-10PB-S	NC					
	PM30-15N-S	NO	NPN	10 ~ 30 VDC	15.0mm	500HZ	Non-Flushed
	PM30-15NB-S	NC					
	PM30-15P-S	NO	PNP				
	PM30-15PB-S	NC					
	PM30-10N	NO	NPN	10 ~ 30 VDC	10.0mm	500HZ	Flushed
	PM30-10NB	NC					
	PM30-10P	NO	PNP				
	PM30-10 PB	NC					
	PM30-15N	NO	NPN	10 ~ 30 VDC	15.0mm	500HZ	Non-Flushed
	PM30-15NB	NC					
	PM30-15P	NO	PNP				
	PM30-15PB	NC					
	PM30-10S	NO	SCR	90 ~ 250 VAC	10.0mm	20HZ	Flushed
	PM30-10SB	NO					
	PM30-15S	NO	SCR	90 ~ 250 VAC	15.0mm	20HZ	Non-Flushed
	PM30-15SB	NO					

Fixed Bracket

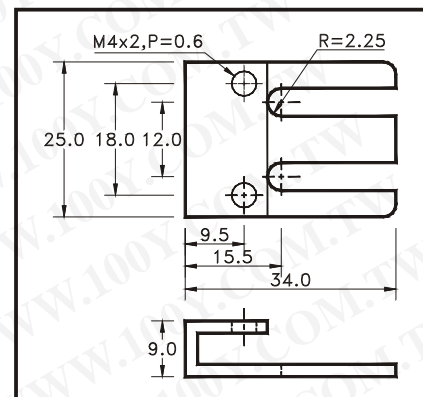
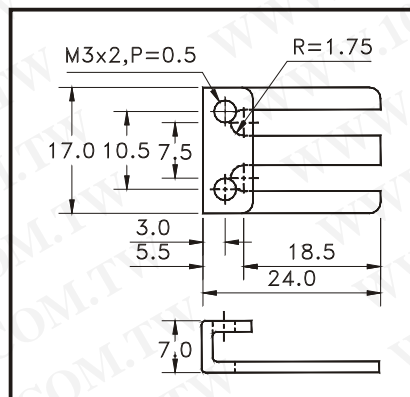
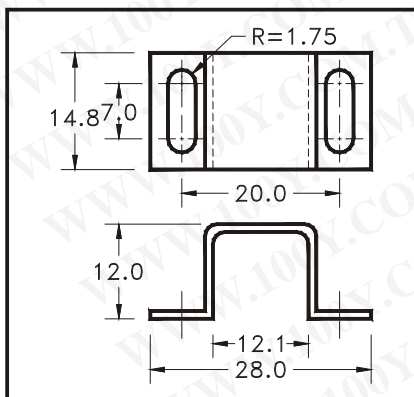

PS/PM series

INDUCTIVE PROXIMITY SENSOR CE

Connecting Method of AND & OR

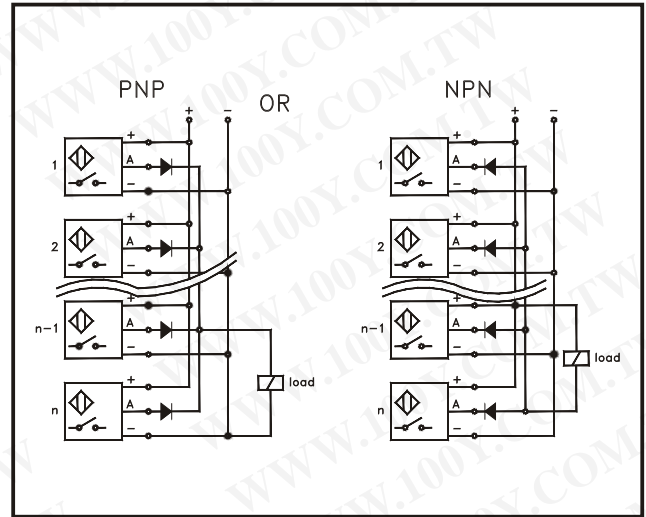
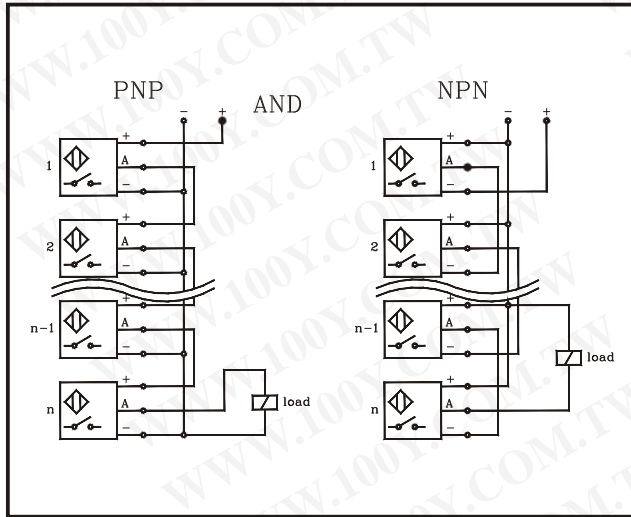

Basic Definition of Inductive Proximity Sensor

Target

Which is steel, 1 mm thick, square form with width lengths equal to the diameter of the sensing surface, if the target is made of a different material, the sensing distance must be multiplied by the Correction Factors.

Accuracy < Repetition >

Tolerance of operating position that sensor is certainly operated under the same conditions.

Hysteresis

Hysteresis is the different distance between the operating points that the target is approaching and leaving the sensing area of the sensor. The value is expressed as a percentage of the sensing distance, $< \Delta d / S_n \% >$.

Switch frequency

This is the maximum response frequency per second, based on a pulse / pause ratio of 1:2. The sketch shows the condition of test.

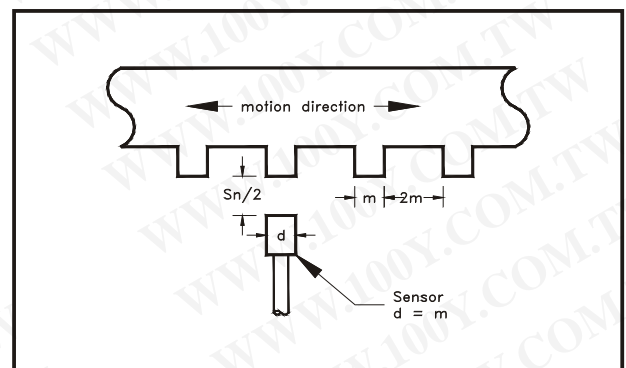
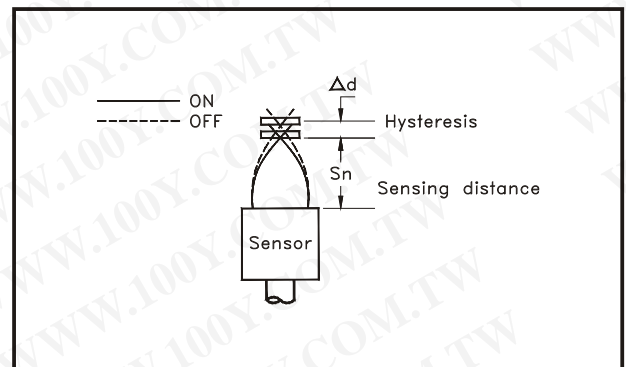
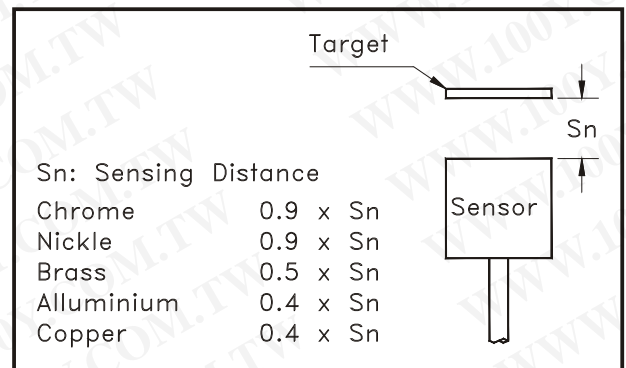

How To Install Induction Proximity Sensor

Flushed type

A proximity sensor can be flushed mounted in metal and surrounded by metal up to the level of the active face.

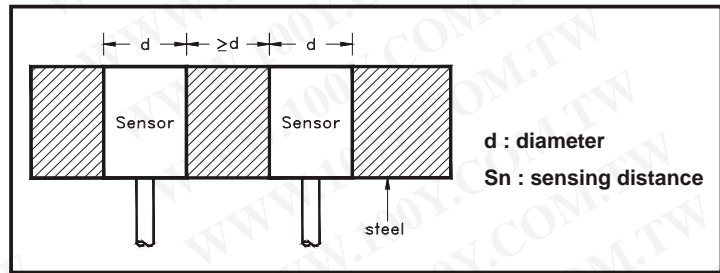

Non-flushed

A proximity sensor cannot be flushed in metal, a clear zone of 3 times of the diameter of the sensing surface must be kept.

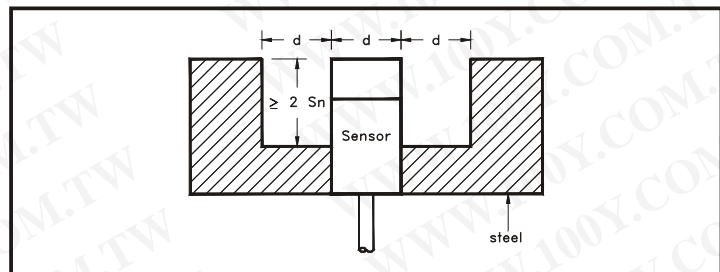

Mutual Interference

Installing inductive proximity sensors of the same model face to face or side by side, please set the minimum distance between the sensors larger than the diameter of sensor, to avoid the malfunction.

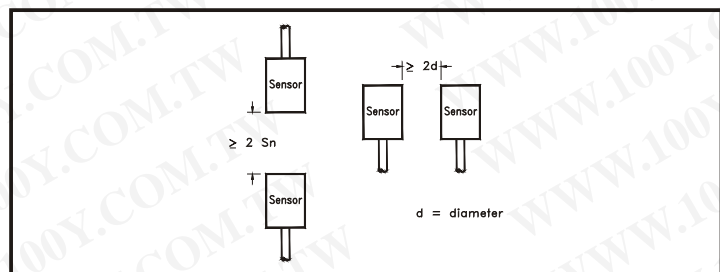

Clamping torque

Be sure to set a spring washer when fixing the sensor.

Don't tighten the sensor's mounting screw of PM series, with a clamping torque higher the right values.

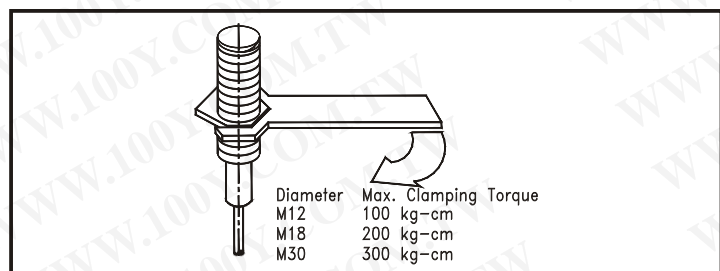

Wiring

To avoid being influenced by noised. Try best to separate the cable of the sensor from power lines and high

If extend the sensor cable, use a cable which diameter as same as that.