

## 2.5-V TO 3.3-V HIGH-PERFORMANCE CLOCK BUFFER

### FEATURES

- High-Performance 1:10 Clock Driver
- Operates up to 200 MHz at  $V_{DD}$  3.3 V
- Pin-to-Pin Skew < 100 ps at  $V_{DD}$  3.3 V
- $V_{DD}$  Range: 2.3 V to 3.6 V
- Operating Temperature Range  $-40^{\circ}\text{C}$  to  $85^{\circ}\text{C}$
- Output Enable Glitch Suppression
- Distributes One Clock Input to Two Banks of Five Outputs
- 25- $\Omega$  On-Chip Series Damping Resistors
- Packaged in 24-Pin TSSOP

### APPLICATIONS

- General-Purpose Applications

### DESCRIPTION

The CDCVF2310 is a high-performance, low-skew clock buffer that operates up to 200 MHz. Two banks of five outputs each provide low-skew copies of CLK. After power up, the default state of the outputs is low regardless of the state of the control pins. For normal operation, the outputs of bank 1Y[0:4] or 2Y[0:4] can be placed in a low state when the control pins (1G or 2G, respectively) are held low and a negative clock edge is detected on the CLK input. The outputs of bank 1Y[0:4] or 2Y[0:4] can be switched into the buffer mode when the control pins (1G and 2G) are held high and a negative clock edge is detected on the CLK input. The device operates in a 2.5-V and 3.3-V environment. The built-in output enable glitch suppression ensures a synchronized output enable sequence to distribute full period clock signals.

The CDCVF2310 is characterized for operation from  $-40^{\circ}\text{C}$  to  $85^{\circ}\text{C}$ .

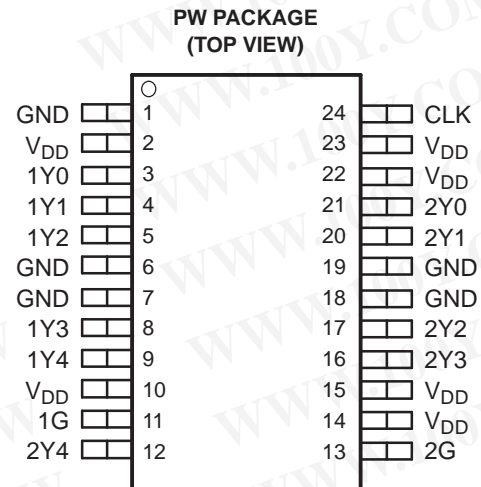

勝特力材料 886-3-5753170  
 勝特力电子(上海) 86-21-34970699  
 勝特力电子(深圳) 86-755-83298787  
[Http://www.100y.com.tw](http://www.100y.com.tw)



Please be aware that an important notice concerning availability, standard warranty, and use in critical applications of Texas Instruments semiconductor products and disclaimers thereto appears at the end of this data sheet.



These devices have limited built-in ESD protection. The leads should be shorted together or the device placed in conductive foam during storage or handling to prevent electrostatic damage to the MOS gates.

FUNCTIONAL BLOCK DIAGRAM

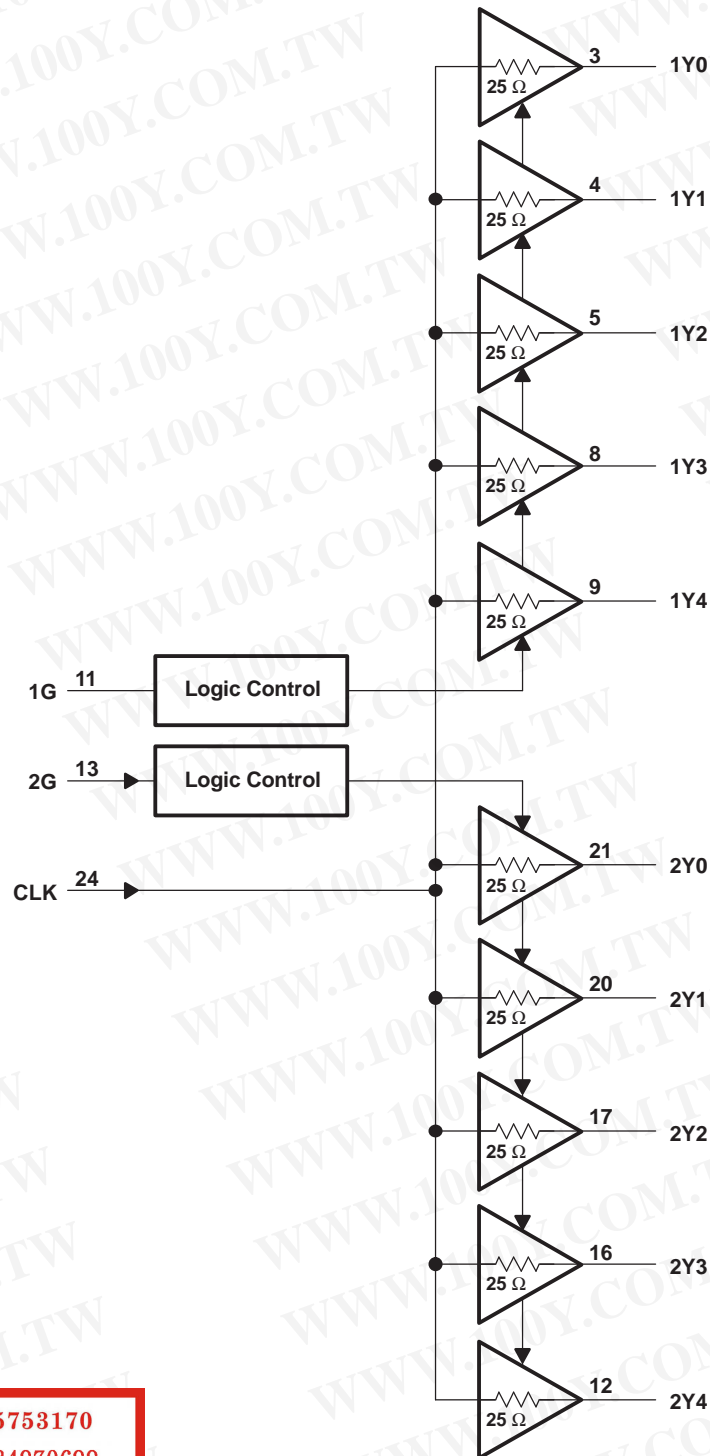

勝特力材料 886-3-5753170  
 勝特力电子(上海) 86-21-34970699  
 勝特力电子(深圳) 86-755-83298787  
[Http://www.100y.com.tw](http://www.100y.com.tw)

**FUNCTION TABLE**

INPUT			OUTPUT	
1G	2G	CLK	1Y[0:4]	2Y[0:4]
L	L	↓	L	L
H	L	↓	CLK <sup>(1)</sup>	L
L	H	↓	L	CLK <sup>(1)</sup>
H	H	↓	CLK <sup>(1)</sup>	CLK <sup>(1)</sup>

- (1) After detecting one negative edge on the CLK input, the output follows the input CLK if the control pin is held high.

**Terminal Functions**

TERMINAL		I/O	DESCRIPTION
NAME	NO.		
1G	11	I	Output enable control for 1Y[0:4] outputs. This output enable is active-high, meaning the 1Y[0:4] clock outputs follow the input clock (CLK) if this pin is logic high.
2G	13	I	Output enable control for 2Y[0:4] outputs. This output enable is active-high, meaning the 2Y[0:4] clock outputs follow the input clock (CLK) if this pin is logic high.
1Y[0:4]	3, 4, 5, 8, 9	O	Buffered output clocks
2Y[0:4]	21, 20, 17, 16, 12	O	Buffered output clocks
CLK	24	I	Input reference frequency
GND	1, 6, 7, 18, 19		Ground
V <sub>DD</sub>	2, 10, 14, 15, 22, 23		DC power supply, 2.3 V – 3.6 V

勝特力材料 886-3-5753170  
 勝特力电子(上海) 86-21-34970699  
 勝特力电子(深圳) 86-755-83298787  
[Http://www.100y.com.tw](http://www.100y.com.tw)

DETAILED DESCRIPTION

Output Enable Glitch Suppression Circuit

The purpose of the glitch suppression circuitry is to ensure the output enable sequence is synchronized with the clock input such that the output buffer is enabled or disabled on the next full period of the input clock (negative edge triggered by the input clock) (see Figure 1).

The G input must fulfill the timing requirements ( $t_{su}$ ,  $t_h$ ) according to the *Switching Characteristics* table for predictable operation.

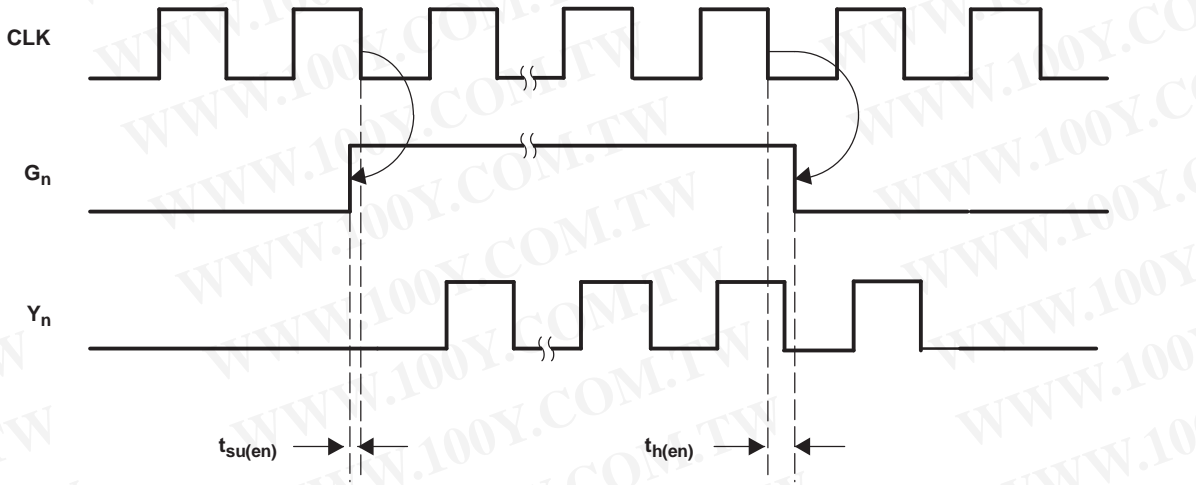

a) Enable Mode

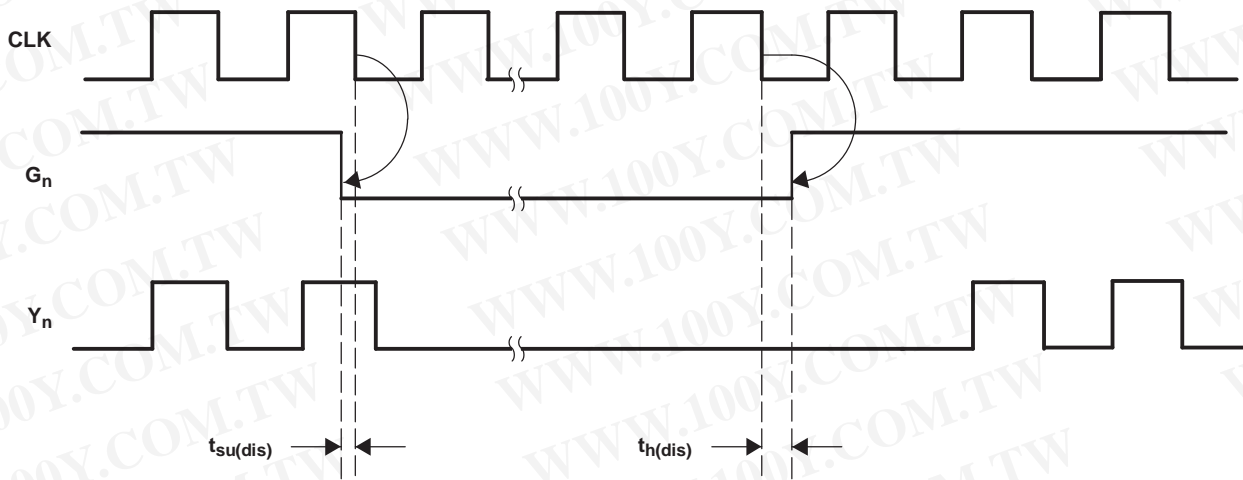

b) Disable Mode

Figure 1. Enable and Disable Mode Relative to CLK↓

勝特力材料 886-3-5753170  
 勝特力电子(上海) 86-21-34970699  
 勝特力电子(深圳) 86-755-83298787  
[Http://www.100y.com.tw](http://www.100y.com.tw)

## ABSOLUTE MAXIMUM RATINGS

over operating free-air temperature range (unless otherwise noted) <sup>(1)</sup>

Supply voltage range, $V_{DD}$	–0.5 V to 4.6 V
Input voltage range, $V_I$ <sup>(2)(3)</sup>	–0.5 V to $V_{DD} + 0.5$ V
Output voltage range, $V_O$ <sup>(2)(3)</sup>	–0.5 V to $V_{DD} + 0.5$ V
Input clamp current, $I_{IK}$ ( $V_I < 0$ or $V_I > V_{DD}$ )	±50 mA
Output clamp current, $I_{OK}$ ( $V_O < 0$ or $V_O > V_{DD}$ )	±50 mA
Continuous total output current, $I_O$ ( $V_O = 0$ to $V_{DD}$ )	±50 mA
Package thermal impedance, $\theta_{JA}$ <sup>(4)</sup> : PW package	120°C/W
Storage temperature range $T_{stg}$	–65°C to 150°C

- (1) Stresses beyond those listed under “absolute maximum ratings” may cause permanent damage to the device. These are stress ratings only, and functional operation of the device at these or any other conditions beyond those indicated under “recommended operating conditions” is not implied. Exposure to absolute-maximum-rated conditions for extended periods may affect device reliability.
- (2) The input and output negative voltage ratings may be exceeded if the input and output clamp-current ratings are observed.
- (3) This value is limited to 4.6 V maximum.
- (4) The package thermal impedance is calculated in accordance with JESD 51.

## RECOMMENDED OPERATING CONDITIONS <sup>(1)</sup>

		MIN	NOM	MAX	UNIT
Supply voltage, $V_{DD}$		2.3	2.5		V
			3.3	3.6	
Low-level input voltage, $V_{IL}$	$V_{DD} = 3$ V to 3.6 V			0.8	V
	$V_{DD} = 2.3$ V to 2.7 V			0.7	
High-level input voltage, $V_{IH}$	$V_{DD} = 3$ V to 3.6 V	2			V
	$V_{DD} = 2.3$ V to 2.7 V	1.7			
Input voltage, $V_I$		0		$V_{DD}$	V
High-level output current, $I_{OH}$	$V_{DD} = 3$ V to 3.6 V			12	mA
	$V_{DD} = 2.3$ V to 2.7 V			6	
Low-level output current, $I_{OL}$	$V_{DD} = 3$ V to 3.6 V			12	mA
	$V_{DD} = 2.3$ V to 2.7 V			6	
Operating free-air temperature, $T_A$		–40		85	°C

- (1) Unused inputs must be held high or low to prevent them from floating.

## ELECTRICAL CHARACTERISTICS

over recommended operating free-air temperature range (unless otherwise noted)

PARAMETER	TEST CONDITIONS	MIN	TYP <sup>(1)</sup>	MAX	UNIT
$V_{IK}$ Input voltage	$V_{DD} = 3$ V, $I_I = -18$ mA			–1.2	V
$I_I$ Input current	$V_I = 0$ V or $V_{DD}$			±5	μA
$I_{DD}$ <sup>(2)</sup> Static device current	CLK = 0 V or $V_{DD}$ , $I_O = 0$ mA			80	μA
$C_I$ Input capacitance	$V_{DD} = 2.3$ V to 3.6 V, $V_I = 0$ V or $V_{DD}$		2.5		pF
$C_O$ Output capacitance	$V_{DD} = 2.3$ V to 3.6 V, $V_I = 0$ V or $V_{DD}$		2.8		pF

- (1) All typical values are at respective nominal  $V_{DD}$ .
- (2) For  $I_{CC}$  over frequency, see [Figure 6](#).

### $V_{DD} = 3.3$ V ±0.3 V

PARAMETER	TEST CONDITIONS	MIN	TYP <sup>(1)</sup>	MAX	UNIT
$V_{OH}$ High-level output voltage	$V_{DD} = \text{min to max}$ , $I_{OH} = -100$ μA	$V_{DD} - 0.2$			V
	$V_{DD} = 3$ V	$I_{OH} = -12$ mA	2.1		
		$I_{OH} = -6$ mA	2.4		

- (1) All typical values are at respective nominal  $V_{DD}$ .

**V<sub>DD</sub> = 3.3 V ±0.3 V (continued)**

PARAMETER		TEST CONDITIONS		MIN	TYP <sup>(1)</sup>	MAX	UNIT
V <sub>OL</sub>	Low-level output voltage	V <sub>DD</sub> = min to max,	I <sub>OL</sub> = -100 μA			0.2	V
		V <sub>DD</sub> = 3 V	I <sub>OL</sub> = 12 mA			0.8	
			I <sub>OL</sub> = 6 mA			0.55	
I <sub>OH</sub>	High-level output current	V <sub>DD</sub> = 3 V,	V <sub>O</sub> = 1 V	-28			mA
		V <sub>DD</sub> = 3.3 V,	V <sub>O</sub> = 1.65 V		-36		
		V <sub>DD</sub> = 3.6 V,	V <sub>O</sub> = 3.135 V			-14	
I <sub>OL</sub>	Low-level output current	V <sub>DD</sub> = 3 V,	V <sub>O</sub> = 1.95 V	28			mA
		V <sub>DD</sub> = 3.3 V,	V <sub>O</sub> = 1.65 V		36		
		V <sub>DD</sub> = 3.6 V,	V <sub>O</sub> = 0.4 V			14	

**V<sub>DD</sub> = 2.5 V ±0.2 V**

PARAMETER		TEST CONDITIONS		MIN	TYP <sup>(1)</sup>	MAX	UNIT
V <sub>OH</sub>	High-level output voltage	V <sub>DD</sub> = min to max,	I <sub>OH</sub> = -100 μA	V <sub>DD</sub> - 0.2			V
		V <sub>DD</sub> = 2.3 V	I <sub>OH</sub> = -6 mA	1.8			
V <sub>OL</sub>	Low-level output voltage	V <sub>DD</sub> = min to max,	I <sub>OL</sub> = 100 μA			0.2	V
		V <sub>DD</sub> = 2.3 V	I <sub>OL</sub> = 6 mA			0.55	
I <sub>OH</sub>	High-level output current	V <sub>DD</sub> = 2.3 V,	V <sub>O</sub> = 1 V	-17			mA
		V <sub>DD</sub> = 2.5 V,	V <sub>O</sub> = 1.25 V		-25		
		V <sub>DD</sub> = 2.7 V,	V <sub>O</sub> = 2.375 V			-10	
I <sub>OL</sub>	Low-level output current	V <sub>DD</sub> = 2.3 V,	V <sub>O</sub> = 1.2 V	17			mA
		V <sub>DD</sub> = 2.5 V,	V <sub>O</sub> = 1.25 V		25		
		V <sub>DD</sub> = 2.7 V,	V <sub>O</sub> = 0.3 V			10	

(1) All typical values are at respective nominal V<sub>DD</sub>.

**TIMING REQUIREMENTS**

over recommended ranges of supply voltage and operating free-air temperature

		MIN	NOM	MAX	UNIT
f <sub>clk</sub>	Clock frequency	V <sub>DD</sub> = 3 V to 3.6 V		0	200
		V <sub>DD</sub> = 2.3 V to 2.7 V		0	170

**JITTER CHARACTERISTICS**

Characterized using CDCVF2310 Performance EVM when V<sub>DD</sub>=3.3 V. Outputs not under test are terminated to 50 Ω.

PARAMETER		TEST CONDITIONS		MIN	TYP	MAX	UNIT
t <sub>jitter</sub>	Additive phase jitter from input to output 1Y0	12 kHz to 5 MHz, f <sub>out</sub> = 30.72 MHz			52		fs rms
		12 kHz to 20 MHz, f <sub>out</sub> = 125 MHz			45		

勝特力材料 886-3-5753170  
 勝特力电子(上海) 86-21-34970699  
 勝特力电子(深圳) 86-755-83298787  
[Http://www.100y.com.tw](http://www.100y.com.tw)

## SWITCHING CHARACTERISTICS

over recommended operating free-air temperature range (unless otherwise noted)

$V_{DD} = 3.3\text{ V} \pm 0.3\text{ V}$  (see Figure 2)

PARAMETER		TEST CONDITIONS	MIN	TYP	MAX	UNIT
$t_{PLH}$	CLK to $Y_n$	$f = 0\text{ MHz to }200\text{ MHz}$ For circuit load, see Figure 2.	1.3		2.8	ns
$t_{PHL}$						
$t_{sk(o)}$	Output skew ( $Y_m$ to $Y_n$ ) <sup>(1)</sup> (see Figure 4)				100	ps
$t_{sk(p)}$	Pulse skew (see Figure 5)				250	ps
$t_{sk(pp)}$	Part-to-part skew				500	ps
$t_r$	Rise time (see Figure 3)	$V_O = 0.4\text{ V to }2\text{ V}$	0.7		2	V/ns
$t_f$	Fall time (see Figure 3)	$V_O = 2\text{ V to }0.4\text{ V}$	0.7		2	V/ns
$t_{su(en)}$	Enable setup time, $G_{high}$ before CLK ↓		0.1			ns
$t_{su(dis)}$	Disable setup time, $G_{low}$ before CLK ↓		0.1			ns
$t_{h(en)}$	Enable hold time, $G_{high}$ after CLK ↓		0.4			ns
$t_{h(dis)}$	Disable hold time, $G_{low}$ after CLK ↓		0.4			ns

(1) The  $t_{sk(o)}$  specification is only valid for equal loading of all outputs.

$V_{DD} = 2.5\text{ V} \pm 0.2\text{ V}$  (see Figure 2)

PARAMETER		TEST CONDITIONS	MIN	TYP	MAX	UNIT
$t_{PLH}$	CLK to $Y_n$	$f = 0\text{ MHz to }170\text{ MHz}$ For circuit load, see Figure 2.	1.5		3.5	ns
$t_{PHL}$						
$t_{sk(o)}$	Output skew ( $Y_m$ to $Y_n$ ) <sup>(1)</sup> (see Figure 4)				170	ps
$t_{sk(p)}$	Pulse skew (see Figure 5)				400	ps
$t_{sk(pp)}$	Part-to-part skew				600	ps
$t_r$	Rise time (see Figure 3)	$V_O = 0.4\text{ V to }1.7\text{ V}$	0.5		1.4	V/ns
$t_f$	Fall time (see Figure 3)	$V_O = 1.7\text{ V to }0.4\text{ V}$	0.5		1.4	V/ns
$t_{su(en)}$	Enable setup time, $G_{high}$ before CLK ↓		0.1			ns
$t_{su(dis)}$	Disable setup time, $G_{low}$ before CLK ↓		0.1			ns
$t_{h(en)}$	Enable hold time, $G_{high}$ after CLK ↓		0.4			ns
$t_{h(dis)}$	Disable hold time, $G_{low}$ after CLK ↓		0.4			ns

(1) The  $t_{sk(o)}$  specification is only valid for equal loading of all outputs.

## PARAMETER MEASUREMENT INFORMATION

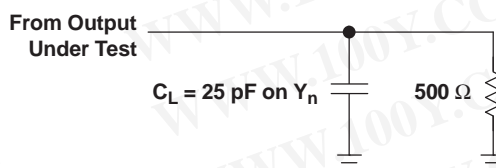

勝特力材料 886-3-5753170  
勝特力电子(上海) 86-21-34970699  
勝特力电子(深圳) 86-755-83298787  
[Http://www.100y.com.tw](http://www.100y.com.tw)

- $C_L$  includes probe and jig capacitance.
- All input pulses are supplied by generators having the following characteristics:  $PRR \leq 200\text{ MHz}$ ,  $Z_O = 50\ \Omega$ ,  $t_r < 1.2\text{ ns}$ ,  $t_f < 1.2\text{ ns}$ .

Figure 2. Test Load Circuit

PARAMETER MEASUREMENT INFORMATION (continued)

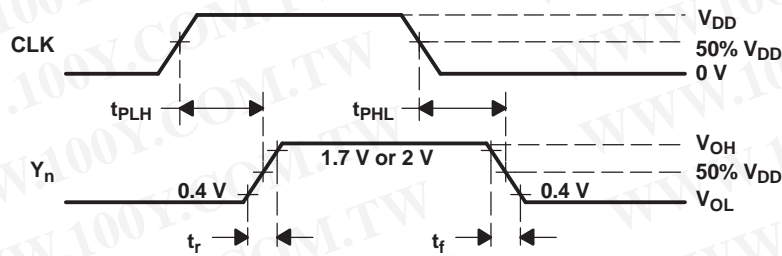

Figure 3. Voltage Waveforms Propagation Delay Times

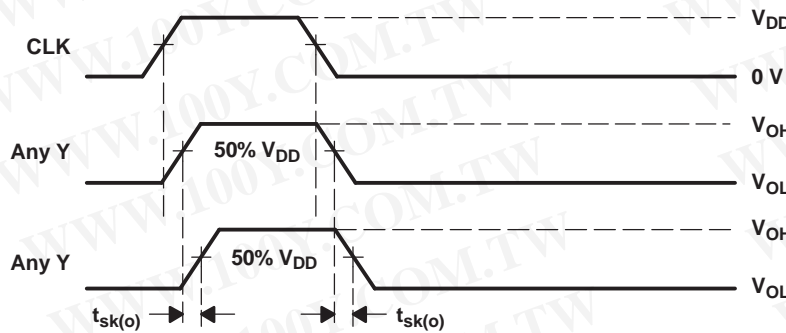
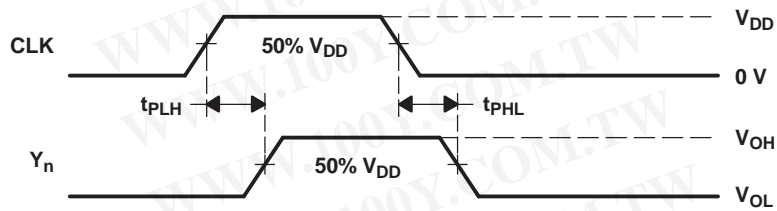

Figure 4. Output Skew



NOTE:  $t_{sk(p)} = |t_{PLH} - t_{PHL}|$

Figure 5. Pulse Skew

勝特力材料 886-3-5753170  
 勝特力电子(上海) 86-21-34970699  
 勝特力电子(深圳) 86-755-83298787  
[Http://www.100y.com.tw](http://www.100y.com.tw)

PARAMETER MEASUREMENT INFORMATION (continued)

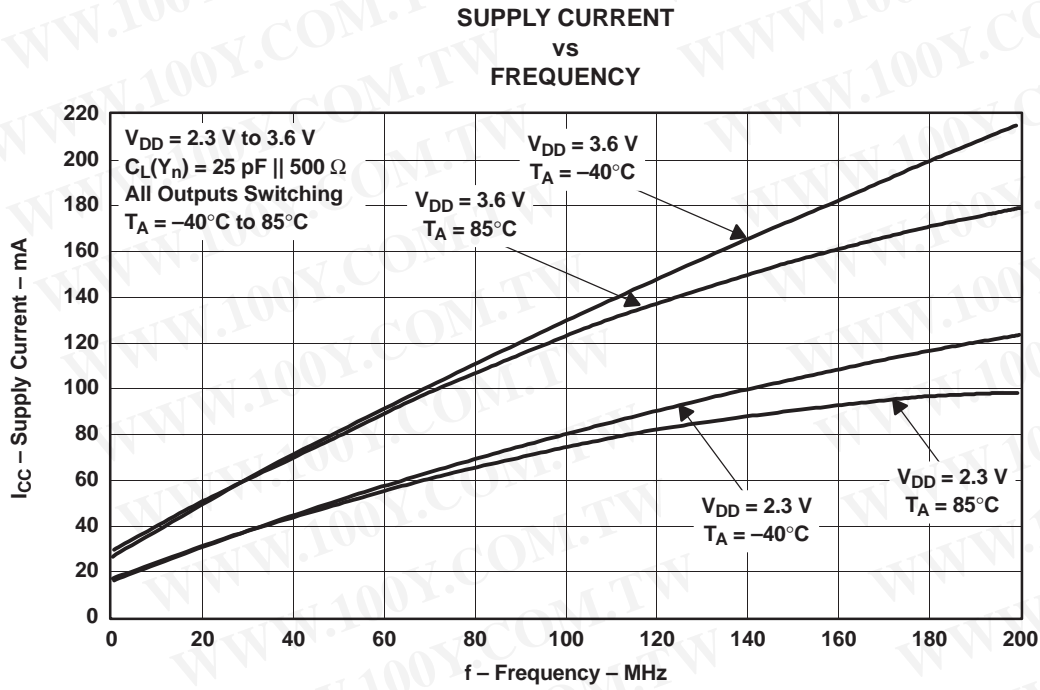

勝特力材料 886-3-5753170  
 勝特力电子(上海) 86-21-34970699  
 勝特力电子(深圳) 86-755-83298787  
[Http://www.100y.com.tw](http://www.100y.com.tw)

**PACKAGING INFORMATION**

Orderable Device	Status <sup>(1)</sup>	Package Type	Package Drawing	Pins	Package Qty	Eco Plan <sup>(2)</sup>	Lead/Ball Finish	MSL Peak Temp <sup>(3)</sup>
CDCVF2310PW	ACTIVE	TSSOP	PW	24	60	Green (RoHS & no Sb/Br)	CU NIPDAU	Level-1-260C-UNLIM
CDCVF2310PWG4	ACTIVE	TSSOP	PW	24	60	Green (RoHS & no Sb/Br)	CU NIPDAU	Level-1-260C-UNLIM
CDCVF2310PWR	ACTIVE	TSSOP	PW	24	2000	Green (RoHS & no Sb/Br)	CU NIPDAU	Level-1-260C-UNLIM
CDCVF2310PWRG4	ACTIVE	TSSOP	PW	24	2000	Green (RoHS & no Sb/Br)	CU NIPDAU	Level-1-260C-UNLIM

<sup>(1)</sup> The marketing status values are defined as follows:

**ACTIVE:** Product device recommended for new designs.

**LIFEBUY:** TI has announced that the device will be discontinued, and a lifetime-buy period is in effect.

**NRND:** Not recommended for new designs. Device is in production to support existing customers, but TI does not recommend using this part in a new design.

**PREVIEW:** Device has been announced but is not in production. Samples may or may not be available.

**OBSOLETE:** TI has discontinued the production of the device.

<sup>(2)</sup> Eco Plan - The planned eco-friendly classification: Pb-Free (RoHS), Pb-Free (RoHS Exempt), or Green (RoHS & no Sb/Br) - please check <http://www.ti.com/productcontent> for the latest availability information and additional product content details.

**TBD:** The Pb-Free/Green conversion plan has not been defined.

**Pb-Free (RoHS):** TI's terms "Lead-Free" or "Pb-Free" mean semiconductor products that are compatible with the current RoHS requirements for all 6 substances, including the requirement that lead not exceed 0.1% by weight in homogeneous materials. Where designed to be soldered at high temperatures, TI Pb-Free products are suitable for use in specified lead-free processes.

**Pb-Free (RoHS Exempt):** This component has a RoHS exemption for either 1) lead-based flip-chip solder bumps used between the die and package, or 2) lead-based die adhesive used between the die and leadframe. The component is otherwise considered Pb-Free (RoHS compatible) as defined above.

**Green (RoHS & no Sb/Br):** TI defines "Green" to mean Pb-Free (RoHS compatible), and free of Bromine (Br) and Antimony (Sb) based flame retardants (Br or Sb do not exceed 0.1% by weight in homogeneous material)

<sup>(3)</sup> MSL, Peak Temp. -- The Moisture Sensitivity Level rating according to the JEDEC industry standard classifications, and peak solder temperature.

**Important Information and Disclaimer:**The information provided on this page represents TI's knowledge and belief as of the date that it is provided. TI bases its knowledge and belief on information provided by third parties, and makes no representation or warranty as to the accuracy of such information. Efforts are underway to better integrate information from third parties. TI has taken and continues to take reasonable steps to provide representative and accurate information but may not have conducted destructive testing or chemical analysis on incoming materials and chemicals. TI and TI suppliers consider certain information to be proprietary, and thus CAS numbers and other limited information may not be available for release.

In no event shall TI's liability arising out of such information exceed the total purchase price of the TI part(s) at issue in this document sold by TI to Customer on an annual basis.

勝特力材料 886-3-5753170  
 勝特力电子(上海) 86-21-34970699  
 勝特力电子(深圳) 86-755-83298787  
[Http://www.100y.com.tw](http://www.100y.com.tw)

**TAPE AND REEL INFORMATION**

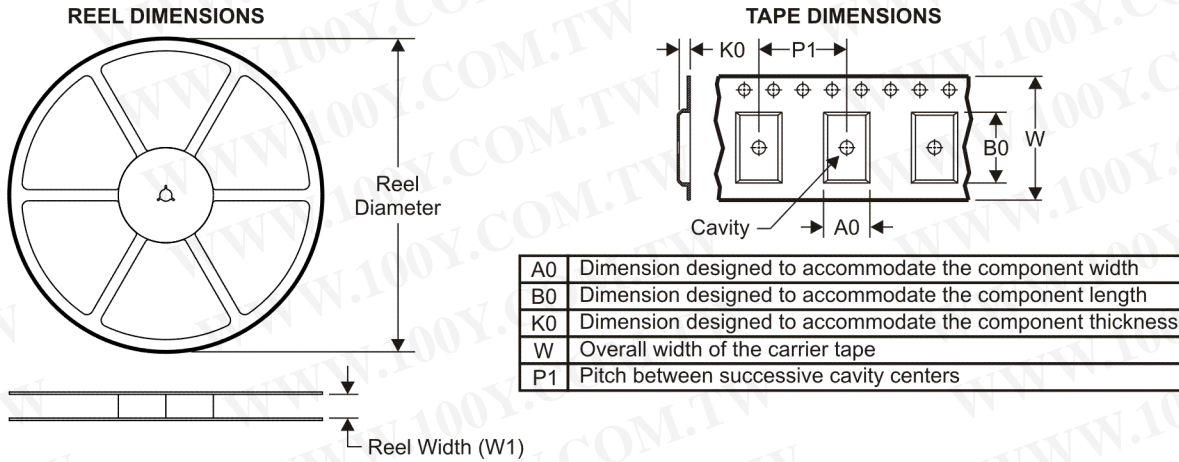

A0	Dimension designed to accommodate the component width
B0	Dimension designed to accommodate the component length
K0	Dimension designed to accommodate the component thickness
W	Overall width of the carrier tape
P1	Pitch between successive cavity centers

**QUADRANT ASSIGNMENTS FOR PIN 1 ORIENTATION IN TAPE**

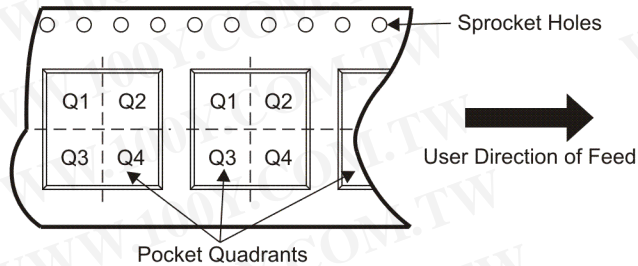

\*All dimensions are nominal

Device	Package Type	Package Drawing	Pins	SPQ	Reel Diameter (mm)	Reel Width W1 (mm)	A0 (mm)	B0 (mm)	K0 (mm)	P1 (mm)	W (mm)	Pin1 Quadrant
CDCVF2310PWR	TSSOP	PW	24	2000	330.0	16.4	6.95	8.3	1.6	8.0	16.0	Q1

勝特力材料 886-3-5753170  
 勝特力电子(上海) 86-21-34970699  
 勝特力电子(深圳) 86-755-83298787  
[Http://www.100y.com.tw](http://www.100y.com.tw)

**TAPE AND REEL BOX DIMENSIONS**

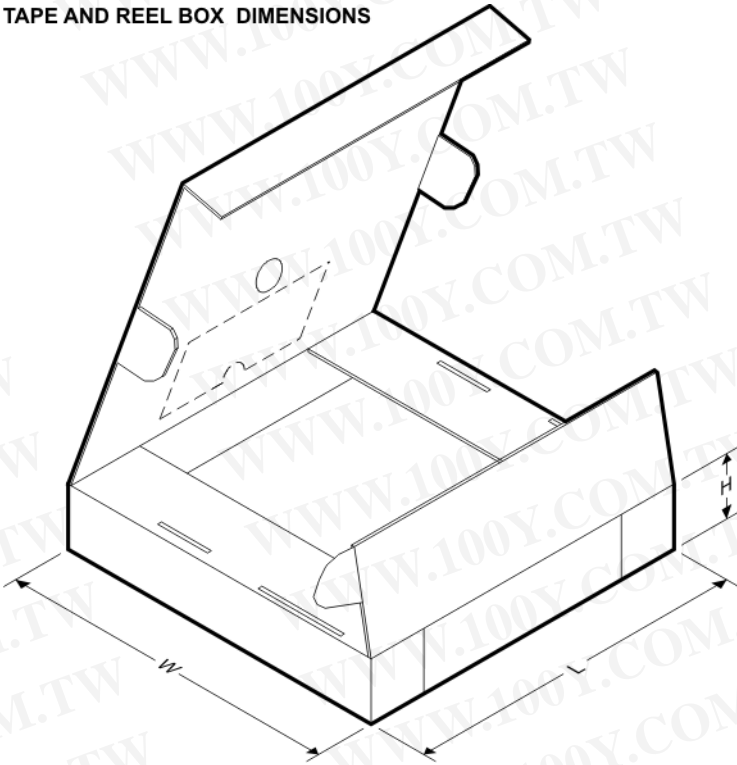

\*All dimensions are nominal

Device	Package Type	Package Drawing	Pins	SPQ	Length (mm)	Width (mm)	Height (mm)
CDCVF2310PWR	TSSOP	PW	24	2000	346.0	346.0	33.0

勝特力材料 886-3-5753170  
 勝特力电子(上海) 86-21-34970699  
 勝特力电子(深圳) 86-755-83298787  
[Http://www.100y.com.tw](http://www.100y.com.tw)

# MECHANICAL DATA

PW (R-PDSO-G24)

PLASTIC SMALL OUTLINE

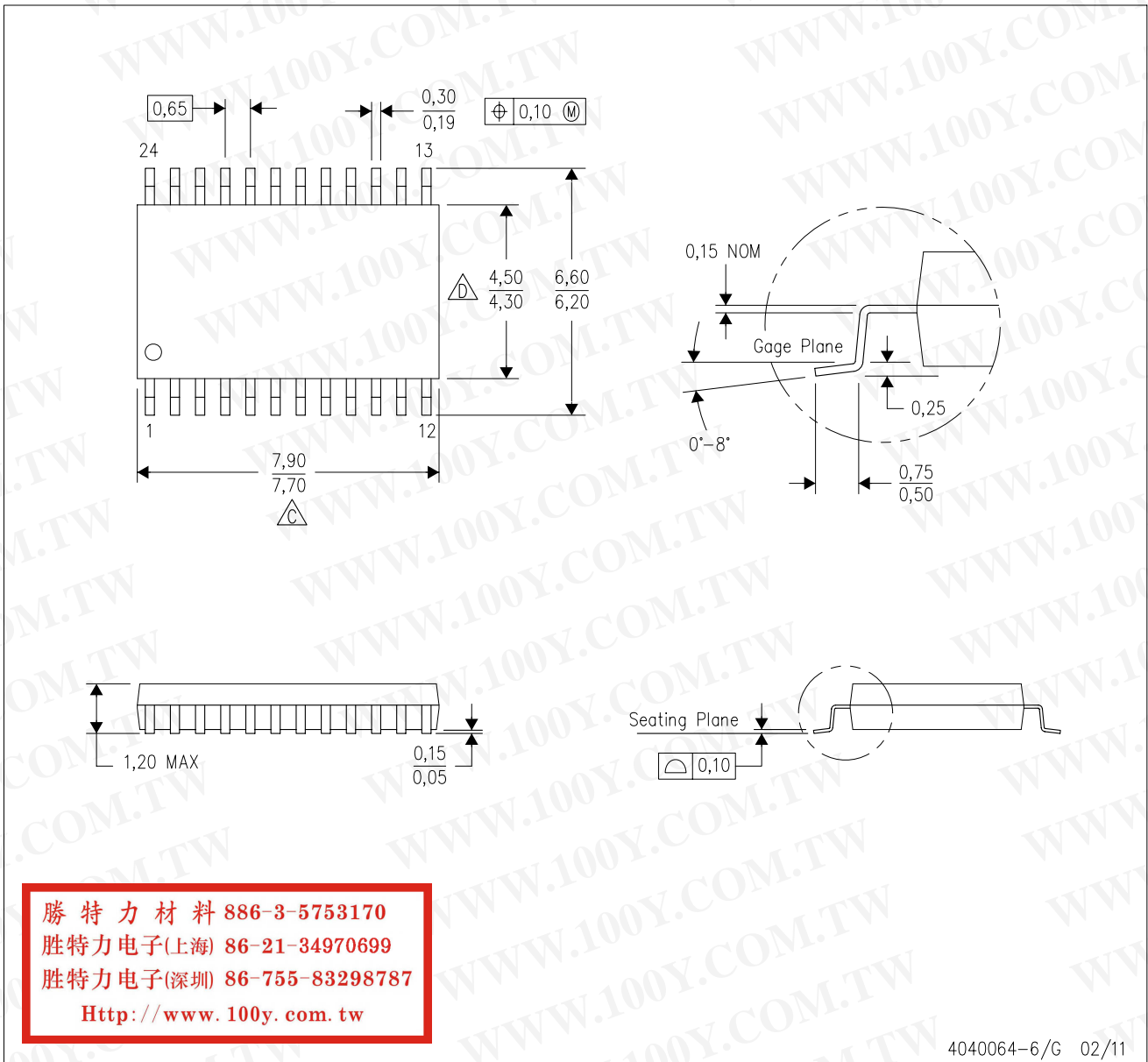

- NOTES:
- A. All linear dimensions are in millimeters. Dimensioning and tolerancing per ASME Y14.5M-1994.
  - B. This drawing is subject to change without notice.
  - C. Body length does not include mold flash, protrusions, or gate burrs. Mold flash, protrusions, or gate burrs shall not exceed 0,15 each side.
  - D. Body width does not include interlead flash. Interlead flash shall not exceed 0,25 each side.
  - E. Falls within JEDEC MO-153

# LAND PATTERN DATA

PW (R-PDSO-G24)

PLASTIC SMALL OUTLINE

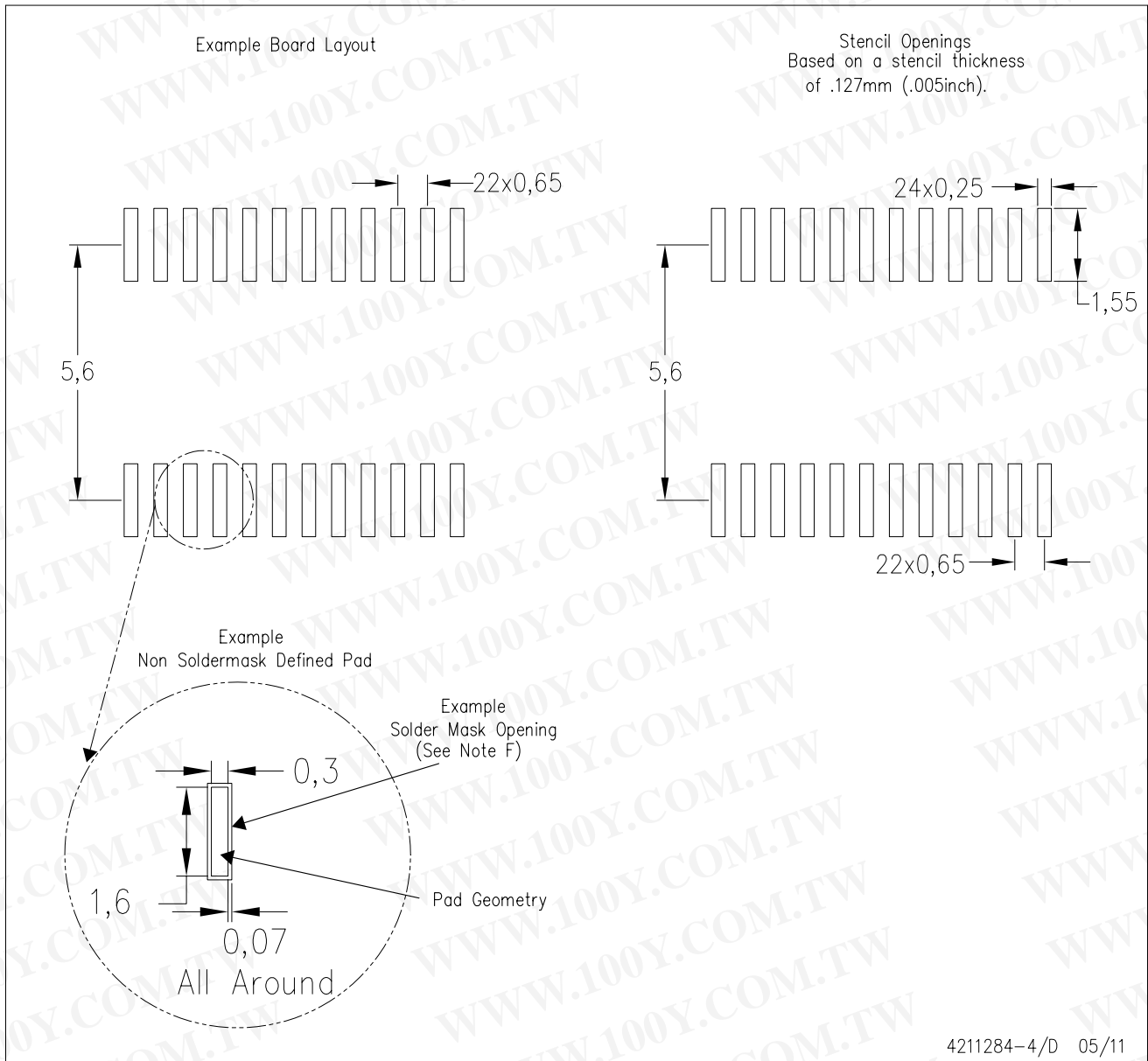

NOTES:

- A. All linear dimensions are in millimeters.
- B. This drawing is subject to change without notice.
- C. Publication IPC-7351 is recommended for alternate design.
- D. Laser cutting apertures with trapezoidal walls and also rounding corners will offer better paste release. Customers should contact their board assembly site for stencil design recommendations. Refer to IPC-7525 for other stencil recommendations.
- E. Customers should contact their board fabrication site for solder mask tolerances between and around signal pads.

**勝特力材料 886-3-5753170**  
**勝特力电子(上海) 86-21-34970699**  
**勝特力电子(深圳) 86-755-83298787**  
[Http://www.100y.com.tw](http://www.100y.com.tw)

## IMPORTANT NOTICE

Texas Instruments Incorporated and its subsidiaries (TI) reserve the right to make corrections, modifications, enhancements, improvements, and other changes to its products and services at any time and to discontinue any product or service without notice. Customers should obtain the latest relevant information before placing orders and should verify that such information is current and complete. All products are sold subject to TI's terms and conditions of sale supplied at the time of order acknowledgment.

TI warrants performance of its hardware products to the specifications applicable at the time of sale in accordance with TI's standard warranty. Testing and other quality control techniques are used to the extent TI deems necessary to support this warranty. Except where mandated by government requirements, testing of all parameters of each product is not necessarily performed.

TI assumes no liability for applications assistance or customer product design. Customers are responsible for their products and applications using TI components. To minimize the risks associated with customer products and applications, customers should provide adequate design and operating safeguards.

TI does not warrant or represent that any license, either express or implied, is granted under any TI patent right, copyright, mask work right, or other TI intellectual property right relating to any combination, machine, or process in which TI products or services are used. Information published by TI regarding third-party products or services does not constitute a license from TI to use such products or services or a warranty or endorsement thereof. Use of such information may require a license from a third party under the patents or other intellectual property of the third party, or a license from TI under the patents or other intellectual property of TI.

Reproduction of TI information in TI data books or data sheets is permissible only if reproduction is without alteration and is accompanied by all associated warranties, conditions, limitations, and notices. Reproduction of this information with alteration is an unfair and deceptive business practice. TI is not responsible or liable for such altered documentation. Information of third parties may be subject to additional restrictions.

Resale of TI products or services with statements different from or beyond the parameters stated by TI for that product or service voids all express and any implied warranties for the associated TI product or service and is an unfair and deceptive business practice. TI is not responsible or liable for any such statements.

TI products are not authorized for use in safety-critical applications (such as life support) where a failure of the TI product would reasonably be expected to cause severe personal injury or death, unless officers of the parties have executed an agreement specifically governing such use. Buyers represent that they have all necessary expertise in the safety and regulatory ramifications of their applications, and acknowledge and agree that they are solely responsible for all legal, regulatory and safety-related requirements concerning their products and any use of TI products in such safety-critical applications, notwithstanding any applications-related information or support that may be provided by TI. Further, Buyers must fully indemnify TI and its representatives against any damages arising out of the use of TI products in such safety-critical applications.

TI products are neither designed nor intended for use in military/aerospace applications or environments unless the TI products are specifically designated by TI as military-grade or "enhanced plastic." Only products designated by TI as military-grade meet military specifications. Buyers acknowledge and agree that any such use of TI products which TI has not designated as military-grade is solely at the Buyer's risk, and that they are solely responsible for compliance with all legal and regulatory requirements in connection with such use.

TI products are neither designed nor intended for use in automotive applications or environments unless the specific TI products are designated by TI as compliant with ISO/TS 16949 requirements. Buyers acknowledge and agree that, if they use any non-designated products in automotive applications, TI will not be responsible for any failure to meet such requirements.

Following are URLs where you can obtain information on other Texas Instruments products and application solutions:

### Products

Audio	<a href="http://www.ti.com/audio">www.ti.com/audio</a>
Amplifiers	<a href="http://amplifier.ti.com">amplifier.ti.com</a>
Data Converters	<a href="http://dataconverter.ti.com">dataconverter.ti.com</a>
DLP® Products	<a href="http://www.dlp.com">www.dlp.com</a>
DSP	<a href="http://dsp.ti.com">dsp.ti.com</a>
Clocks and Timers	<a href="http://www.ti.com/clocks">www.ti.com/clocks</a>
Interface	<a href="http://interface.ti.com">interface.ti.com</a>
Logic	<a href="http://logic.ti.com">logic.ti.com</a>
Power Mgmt	<a href="http://power.ti.com">power.ti.com</a>
Microcontrollers	<a href="http://microcontroller.ti.com">microcontroller.ti.com</a>
RFID	<a href="http://www.ti-rfid.com">www.ti-rfid.com</a>
RF/IF and ZigBee® Solutions	<a href="http://www.ti.com/lprf">www.ti.com/lprf</a>

### Applications

Communications and Telecom	<a href="http://www.ti.com/communications">www.ti.com/communications</a>
Computers and Peripherals	<a href="http://www.ti.com/computers">www.ti.com/computers</a>
Consumer Electronics	<a href="http://www.ti.com/consumer-apps">www.ti.com/consumer-apps</a>
Energy and Lighting	<a href="http://www.ti.com/energy">www.ti.com/energy</a>
Industrial	<a href="http://www.ti.com/industrial">www.ti.com/industrial</a>
Medical	<a href="http://www.ti.com/medical">www.ti.com/medical</a>
Security	<a href="http://www.ti.com/security">www.ti.com/security</a>
Space, Avionics and Defense	<a href="http://www.ti.com/space-avionics-defense">www.ti.com/space-avionics-defense</a>
Transportation and Automotive	<a href="http://www.ti.com/automotive">www.ti.com/automotive</a>
Video and Imaging	<a href="http://www.ti.com/video">www.ti.com/video</a>
Wireless	<a href="http://www.ti.com/wireless-apps">www.ti.com/wireless-apps</a>

TI E2E Community Home Page

[e2e.ti.com](http://e2e.ti.com)

Mailing Address: Texas Instruments, Post Office Box 655303, Dallas, Texas 75265  
Copyright © 2011, Texas Instruments Incorporated

勝特力材料 886-3-5753170  
勝特力电子(上海) 86-21-34970699  
勝特力电子(深圳) 86-755-83298787  
[Http://www.100y.com.tw](http://www.100y.com.tw)