



Subwoofer Cross-Over Low Pass Filter IC

PT2351

DESCRIPTION

PT2351 is an 8-pin subwoofer cross-over low pass filter chip utilizing CMOS Technology having a slope rate of -12dB/oct or -18 dB/oct. Using an external capacitor, the roll-off point can be adjusted to meet your needs or taste. PT2351 has low distortion, high input impedance and low output impedance design. The application circuit and pin assignments are optimized for easy PCB Layout and cost saving benefits.

FEATURES

- CMOS Technology
- Single Power Supply: 3V to 9V
- Second Order Low Pass Filter Design with Slope Rate = -12dB/oct
- Third Order Low Pass Filter Design with Slope Rate = -18 dB/oct
- Low Output Impedance (Typ. 40 Ohms)
- Least External Components
- The Roll-Off Point can be adjusted using an External Capacitor
- 2-Channel Inputs are mixed to a Single Subwoofer Output
- Available in 8-pin, SO or DIP Package

APPLICATIONS

- Multi-Media Audio Subwoofer System
- Audio Equipment
- Sound Card
- Home Theater System



Subwoofer Cross-Over Low Pass Filter IC

PT2351

PIN CONFIGURATION

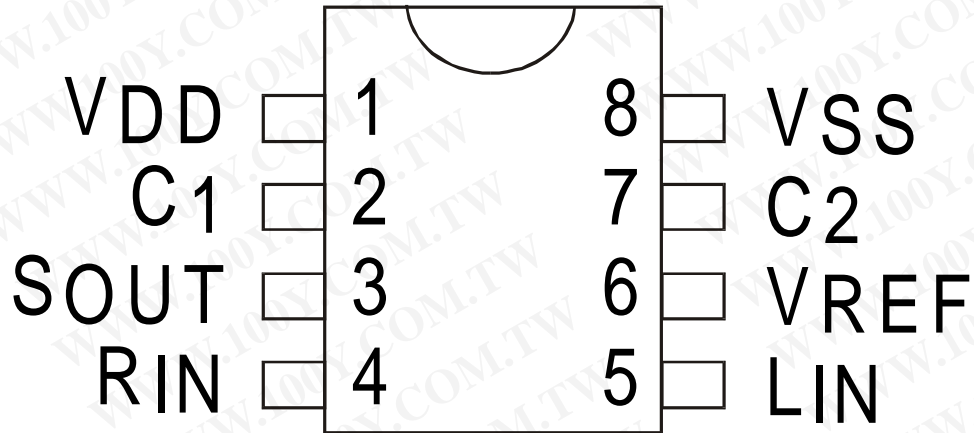

PT2351

ORDER INFORMATION

Valid Part Number	Package Type
PT2351	8 Pins, DIP
PT2351-S	8 Pins, SO



Subwoofer Cross-Over Low Pass Filter IC

PT2351

SECOND ORDER LOW PASS FILTER APPLICATION CIRCUIT

The Second Order Low Pass Filter application circuit only needs very few components. The Cross-Over Filter Point can be adjusted by modifying the values of capacitors -- C1, and C2. For better circuit characteristic, it is recommended that C2 be twice the value of C1. Please refer to the diagram below.

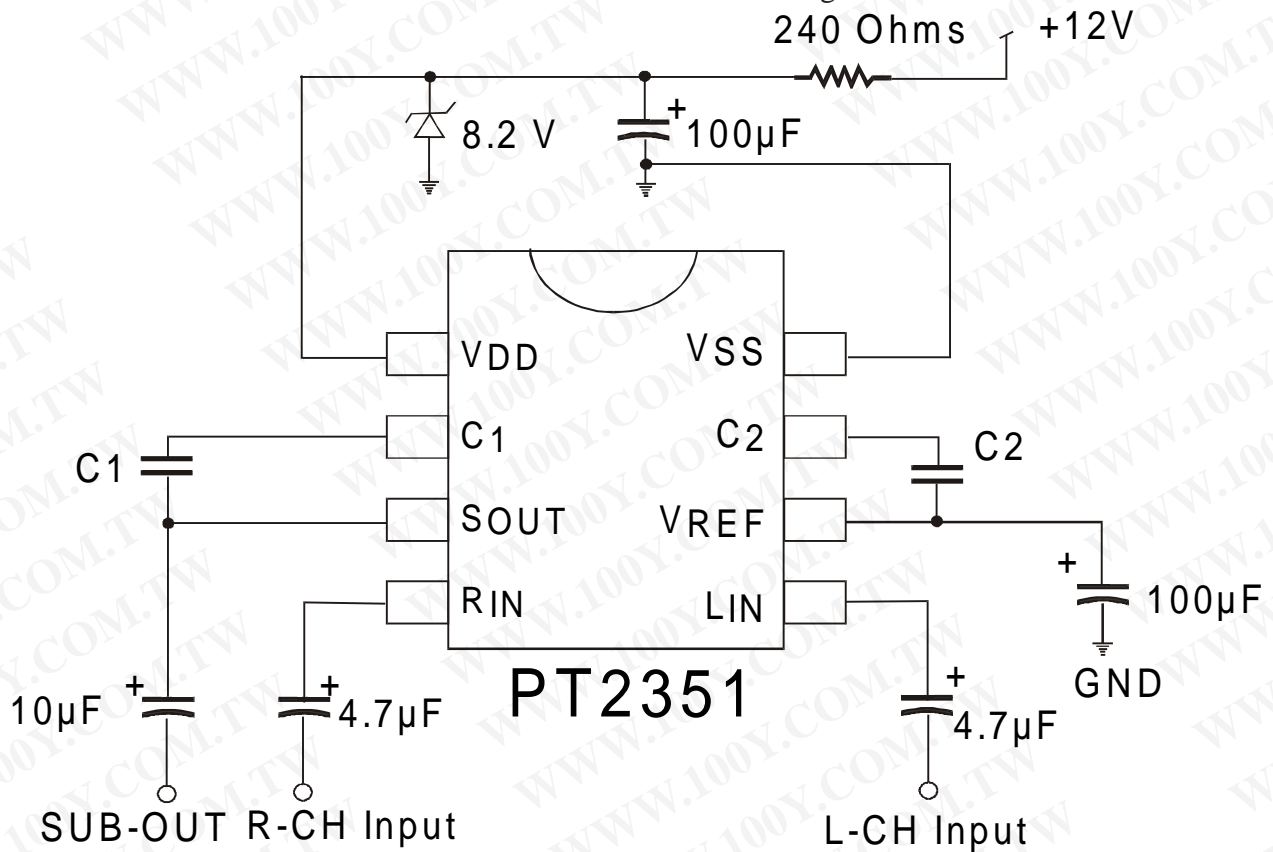



Subwoofer Cross-Over Low Pass Filter IC

PT2351

THIRD ORDER APPLICATION CIRCUIT

If you need more High Frequency Attenuation, then you just need to add the R-C group between the capacitor 4.7 μ F and the Input terminals (RIN and LIN) to achieve a Third Order Frequency Response. Please refer to the diagram below.

