

10-Bit, 2-Port Bus Switch

Features:

- Near-Zero propagation delay
- 5Ω switches connect inputs to outputs
- Direct bus connection when switches are ON
- Ultra-low quiescent power (0.2μA typical)
 - Ideally suited for notebook applications
- Packaging (Pb-free & Green Available):
 - 24-pin 150-mil wide plastic QSOP (Q)
 - 24-pin 300-mil wide plastic SOIC (S)
 - 24-pin 173-mil wide plastic TSSOP (L)

Description:

Pericom Semiconductor's PI5C3384 and PI5C3384C are 10-bit, 2-port bus switches designed with a low On-Resistance allowing inputs to be connected directly to outputs. The bus switch creates no additional propagational delay or additional ground bounce noise. The switches are turned ON by the Bus Enable (\overline{BEx}) input signals. Two bus enable signals are provided, one for each of the upper and lower five bits of the two 10-bit buses.

勝特力材料 886-3-5753170
 勝特力电子(上海) 86-21-34970699
 勝特力电子(深圳) 86-755-83298787
[Http://www.100y.com.tw](http://www.100y.com.tw)

Block Diagram

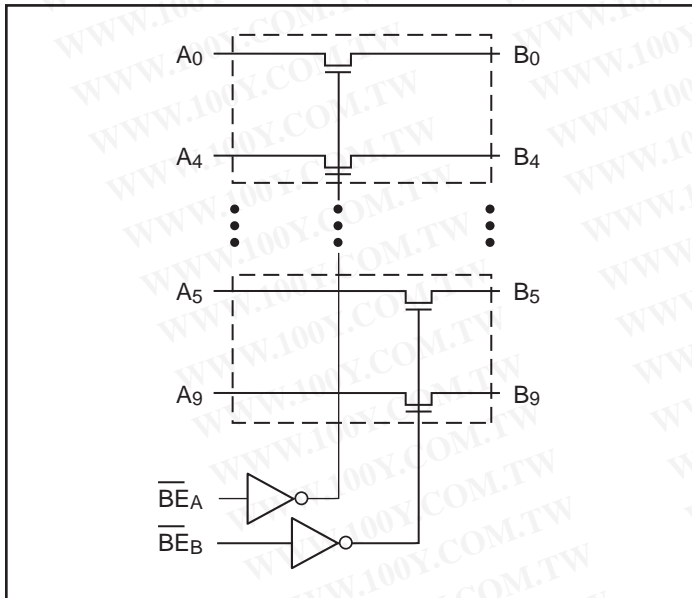

Pin Configuration

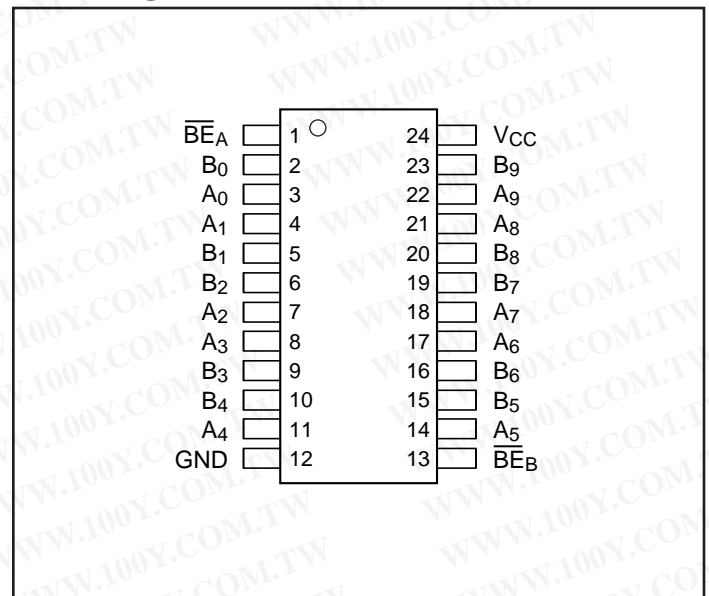

Truth Table⁽¹⁾

Function	\overline{BE}_A	\overline{BE}_B	B ₀ -B ₄	B ₅ -B ₉
Disconnect	H	H	Hi-Z	Hi-Z
Connect	L	H	A ₀ -A ₄	Hi-Z
Connect	H	L	Hi-Z	A ₅ -A ₉
Connect	L	L	A ₀ -A ₄	A ₅ -A ₉

Note:

1. H = High Voltage Level
- X = Don't Care
- L = Low Voltage Level
- Hi-Z = High Impedance

Pin Description

Pin Name	Description
\overline{BE}_A , \overline{BE}_B	Bus Enable Inputs (Active LOW)
A ₀ -A ₉	Bus A
B ₀ -A ₉	Bus B
GND	Ground
V _{CC}	Power

Maximum Ratings

(Above which the useful life may be impaired. For user guidelines, not tested.)

Storage Temperature	-65°C to +150°C
Ambient Temperature with Power Applied	-40°C to +85°C
Supply Voltage to Ground Potential (Inputs & V _{CC} Only).....	-0.5V to +7.0V
Supply Voltage to Ground Potential (Outputs & D/O Only)	-0.5V to +7.0V
DC Input Voltage	-0.5V to +7.0V
DC Output Current.....	120 mA
Power Dissipation	0.5W

Note:

Stresses greater than those listed under MAXIMUM RATINGS may cause permanent damage to the device. This is a stress rating only and functional operation of the device at these or any other conditions above those indicated in the operational sections of this specification is not implied. Exposure to absolute maximum rating conditions for extended periods may affect reliability.

DC Electrical Characteristics (Over the Operating Range, T_A = -40°C to +85°C, V_{CC} = 5V ±5%)

Parameters	Description	Test Conditions ⁽¹⁾	Min.	Typ. ⁽²⁾	Max.	Units
V _{IH}	Input HIGH Voltage	Guaranteed Logic HIGH Level	2.0			V
V _{IL}	Input LOW Voltage	Guaranteed Logic LOW Level	-0.5		0.8	
I _{IH}	Input HIGH Current	V _{CC} = Max., V _{IN} = V _{CC}	-1		1	μA
I _{IL}	Input LOW Current	V _{CC} = Max., V _{IN} = GND	-1		1	
I _{OZ}	High-Impedance Output Current	0 ≤ A, B ≤ V _{CC}	-1		1	
V _{IK}	Clamp Diode Voltage	V _{CC} = Min. I _{IN} = -18 mA		-0.7	-1.2	V
		PI5C3384C			-1.8	
I _{OS}	Short Circuit Current ⁽³⁾	A (B) = 0V, B (A) = V _{CC}	100			mA
V _H	Input Hysteresis at Control Pins			150		mV
R _{ON}	Switch On-Resistance ⁽⁴⁾	V _{CC} = Min. V _{IN} = 0V I _{ON} = 48 mA		5	7	Ω
		V _{CC} = Min. V _{IN} = 2.4V I _{ON} = 15mA		10	15	

Notes:

1. For Max. or Min. conditions, use appropriate value specified under Electrical Characteristics for the applicable device type.
2. Typical values are at V_{CC} = 5.0V, T_A = 25°C ambient and maximum loading.
3. Not more than one output should be shorted at one time. Duration of the test should not exceed one second.
4. Measured by the voltage drop between A and B pin at indicated current through the switch. On-Resistance is determined by the lower of the voltages on the two (A,B) pins.

勝特力材料 886-3-5753170
 勝特力电子(上海) 86-21-34970699
 勝特力电子(深圳) 86-755-83298787
[Http://www.100y.com.tw](http://www.100y.com.tw)

Capacitance ($T_A = 25^\circ\text{C}$, $f = 1\text{ MHz}$)

Parameters ⁽¹⁾	Description	Test Conditions	Typ.	Max.	Units
C_{IN}	Input Capacitance	$V_{IN} = 0\text{V}$		6	pF
C_{OFF}	A/B Capacitance, Switch Off			6	
C_{ON}	A/B Capacitance, Switch On			8	

Notes:

1. This parameter is determined by device characterization but is not production tested.

Power Supply Characteristics

Parameters	Description	Test Conditions ⁽¹⁾	Min.	Typ. ⁽²⁾	Max.	Units
I_{CC}	Quiescent Power Supply Current	$V_{CC} = \text{Max.},$ $V_{IN} = \text{GND or } V_{CC}$	PI5C3384	0.1	3.0	μA
			PI5C3384C	60	100	
ΔI_{CC}	Supply Current per Input @ TTL HIGH	$V_{CC} = \text{Max.},$ $V_{IN} = 3.4\text{V}^{(3)}$			2.5	mA
I_{CCD}	Supply Current per Input per MHz ⁽⁴⁾	$V_{CC} = \text{Max.},$ A and B Pins Open BE1 or BE2 = GND Control Input Toggling 50% Duty Cycle			0.25	mA/ MHz

Notes:

1. For Max. or Min. conditions, use appropriate value specified under Electrical Characteristics for the applicable device.
2. Typical values are at $V_{CC} = 5.0\text{V}$, $+25^\circ\text{C}$ ambient.
3. Per TTL driven input ($V_{IN} = 3.4\text{V}$, control inputs only); A and B pins do not contribute to I_{CC} .
4. This current applies to the control inputs only and represent the current required to switch internal capacitance at the specified frequency. The A and B inputs generate no significant AC or DC currents as they transition. This parameter is not tested, but is guaranteed by design.

Switching Characteristics over Operating Range

Parameters	Description	Conditions ⁽¹⁾	PI5C3384/3384C			Unit
			Min.	Typ.	Max.	
t_{PLH} t_{PHL}	Propagation Delay ^(2,3) Ax to Bx, Bx to Ax	$C_L = 50\text{pF}$ $R_L = 500\Omega$		0.25		ns
t_{pZH} t_{pZL}	Bus Enable Time BEx to Ax or Bx		1.5		6.5	
t_{pHZ} t_{pLZ}	Bus Disable Time BEx to Ax or Bx		1.5		5.5	

Notes:

1. See test circuit and waveforms.
2. This parameter is guaranteed but not tested on Propagation Delays.
3. The bus switch contributes no propagational delay other than the RC delay of the On-Resistance of the switch and the load capacitance. The time constant for the switch alone is of the order of 0.25ns for 50pF load. Since this time constant is much smaller than the rise/fall times of typical driving signals, it adds very little propagational delay to the system. Propagational delay of the bus switch when used in a system is determined by the driving circuit on the driving side of the switch and its interaction with the load on the driven side.

勝特力材料 886-3-5753170
勝特力电子(上海) 86-21-34970699
勝特力电子(深圳) 86-755-83298787
[Http://www.100y.com.tw](http://www.100y.com.tw)

Test Circuit

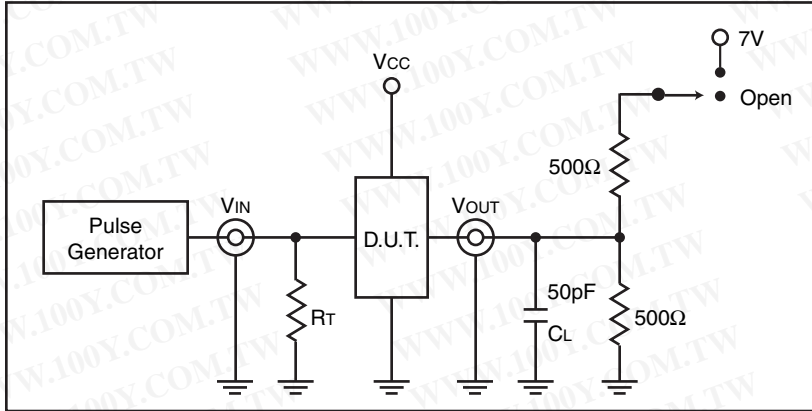

Switch Position

Test	Switch
Disable LOW	Closed
Enable LOW	Closed
t_{PD}	Open

Definitions:
 C_L = Load capacitance (includes jig and probe capacitance)
 R_T = Termination resistance (should be equal to Z_{OUT} of the pulse generator)

Enable and Disable Timing Diagram

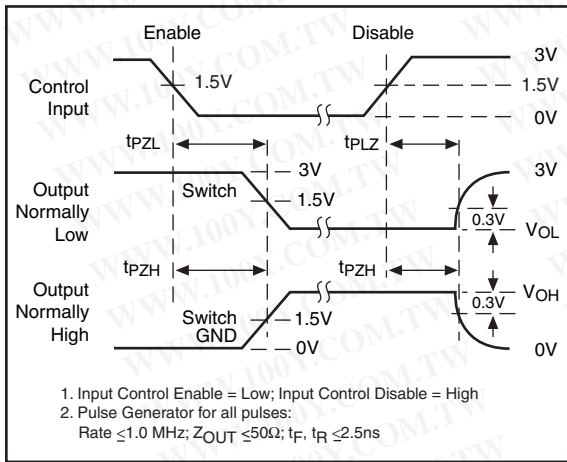

Propagation Delay Diagram

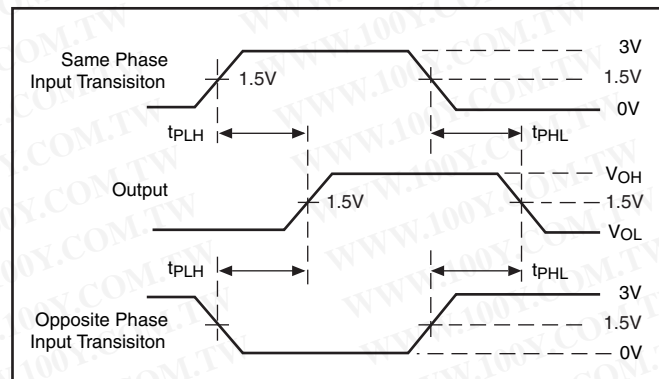

勝特力材料 886-3-5753170
 勝特力电子(上海) 86-21-34970699
 勝特力电子(深圳) 86-755-83298787
[Http://www.100y.com.tw](http://www.100y.com.tw)

Packaging Mechanical: 24-pin TSSOP (L)

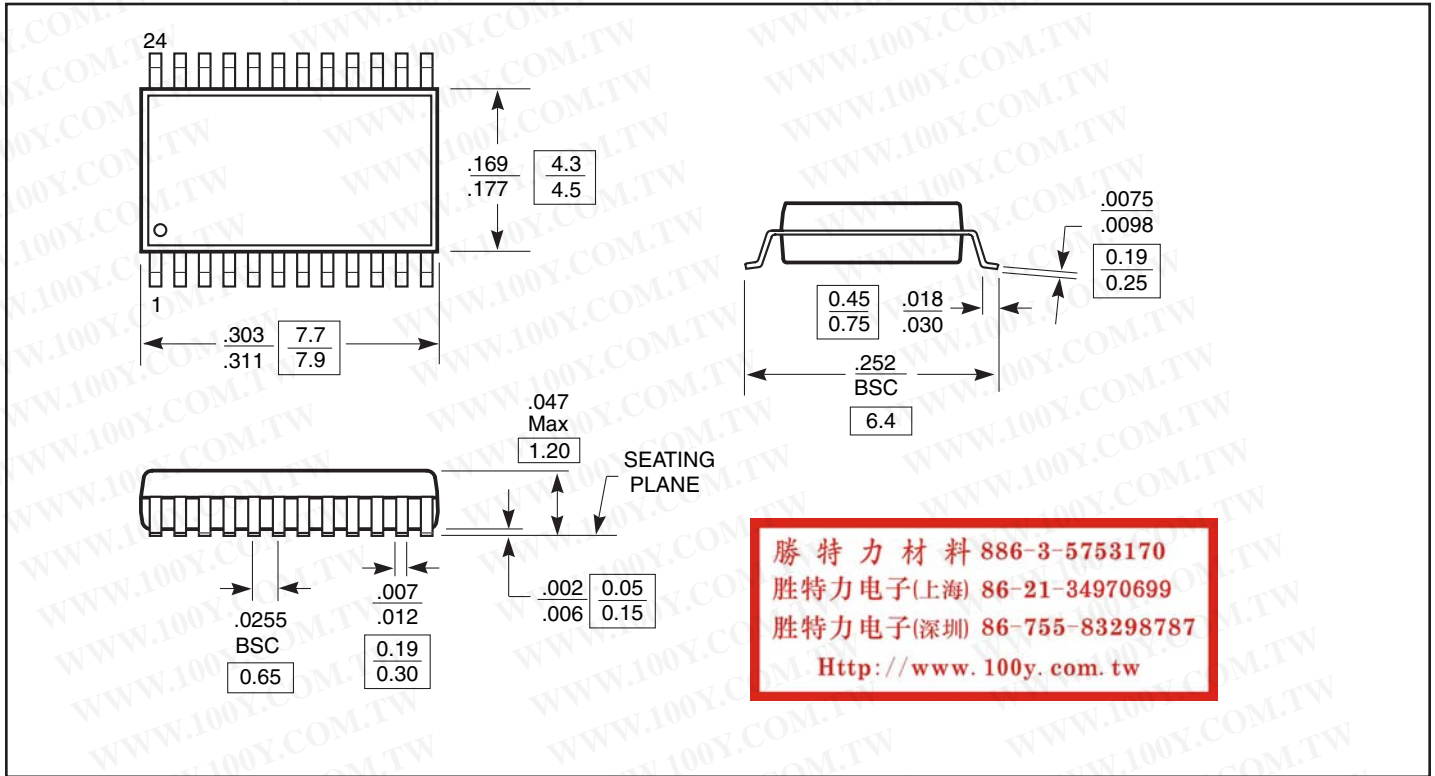

Packaging Mechanical: 24-pin QSOP (Q)

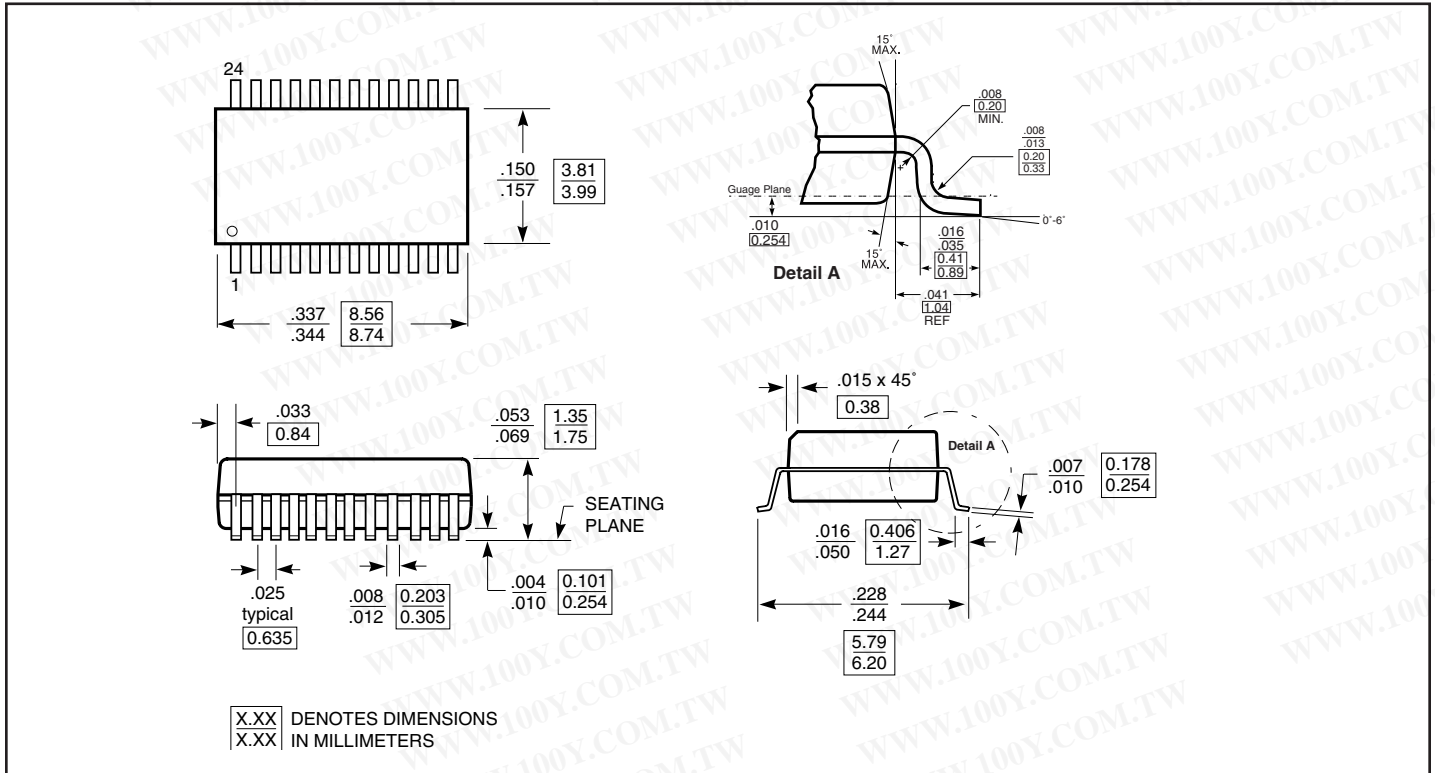

Packaging Mechanical: 24-pin SOIC (S)

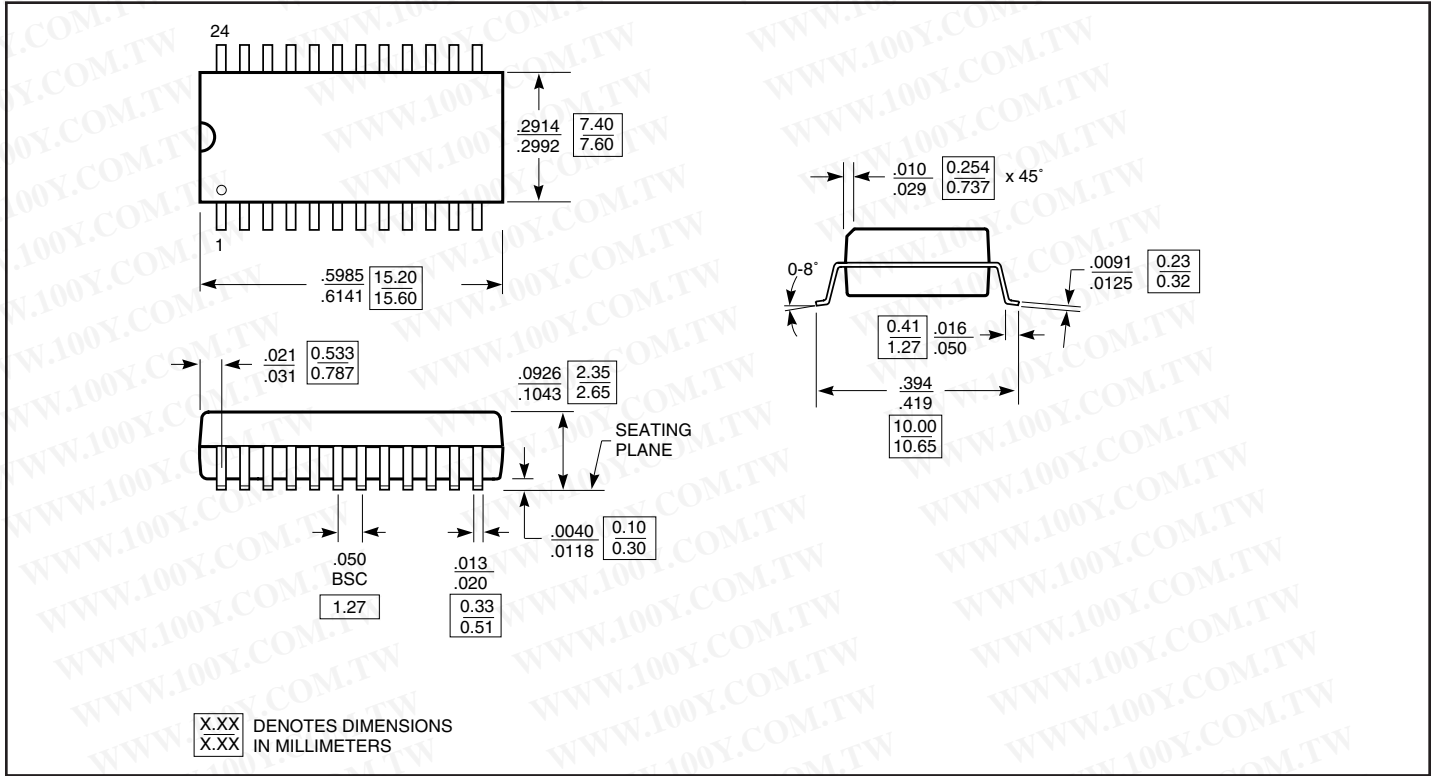

Ordering Information

Ordering Code	Package Code	Package Description
PI5C3384L	L	24-pin 173-mil wide plastic TSSOP
PI5C3384LE	L	Pb-free & Green, 24-pin 173-mil wide plastic TSSOP
PI5C3384Q	Q	24-pin 150-mil wide plastic QSOP
PI5C3384QE	Q	Pb-free & Green, 24-pin 150-mil wide plastic QSOP
PI5C3384S	S	24-pin 300-mil wide plastic SOIC
PI5C3384CQ	Q	24-pin 150-mil wide plastic QSOP
PI5C3384CQE	Q	Pb-free & Green, 24-pin 150-mil wide plastic QSOP

Notes:

- Thermal characteristics can be found on the company web site at www.pericom.com/packaging/
- E = Pb-free & Green
- Adding an X suffix = Tape/Reel

勝特力材料 886-3-5753170
 勝特力电子(上海) 86-21-34970699
 勝特力电子(深圳) 86-755-83298787
[Http://www.100y.com.tw](http://www.100y.com.tw)