

勝特力材料 886-3-5753170
 勝特力电子(上海) 86-21-34970699
 勝特力电子(深圳) 86-755-83298787
 Http://www.100y.com.tw

MAXIM

Dual, 5Ω Analog Switches

MAX4621/MAX4622/MAX4623

General Description

The MAX4621/MAX4622/MAX4623 are precision, dual, high-speed analog switches. The single-pole/single-throw (SPST) MAX4621 and double-pole/single-throw (DPST) MAX4623 dual switches are normally open (NO). The single-pole/double-throw (SPDT) MAX4622 has two normally closed (NC) and two NO poles. All three parts offer low 5Ω on-resistance guaranteed to match to within 0.5Ω between channels and to remain flat over the full analog signal range ($\Delta 0.5\Omega$ max). They also offer low leakage (<500pA at +25°C, <5nA at +85°C) and fast switching times (turn-on time <250ns, turn-off time <200ns).

These analog switches are ideal in low-distortion applications and are the preferred solution over mechanical relays in automatic test equipment or applications where current switching is required. They have low power requirements, use less board space, and are more reliable than mechanical relays.

The MAX4621/MAX4622/MAX4623 are pin-compatible replacements for the DG401/DG403/DG405, respectively, offering improved overall performance. These monolithic switches operate from a single positive supply (+4.5V to +36V) or with bipolar supplies ($\pm 4.5V$ to $\pm 18V$) while retaining CMOS-logic input compatibility.

Rail-to-Rail is a registered trademark of Nippon Motorola, Ltd.

Features

- ◆ Low On-Resistance: 3Ω (typ), 5Ω (max)
- ◆ Guaranteed RON Match Between Channels (0.5Ω max)
- ◆ Guaranteed Break-Before-Make Operation (MAX4622)
- ◆ Guaranteed Off-Channel Leakage <5nA at +85°C
- ◆ Single-Supply Operation (+4.5V to +36V)
Bipolar-Supply Operation ($\pm 4.5V$ to $\pm 18V$)
- ◆ TTL/CMOS-Logic Compatible
- ◆ Rail-to-Rail® Analog Signal Handling Capability
- ◆ Pin Compatible with DG401/DG403/DG405

Applications

Reed Relay Replacement	Military Radios
Test Equipment	PBX, PABX Systems
Communication Systems	Audio-Signal Routing
Data-Acquisition Systems	Avionics

Ordering Information

PART	TEMP. RANGE	PIN-PACKAGE
MAX4621CSE	0°C to +70°C	16 Narrow SO
MAX4621CPE	0°C to +70°C	16 Plastic DIP

Ordering Information continued at end of data sheet.

Pin Configurations/Functional Diagrams/Truth Tables

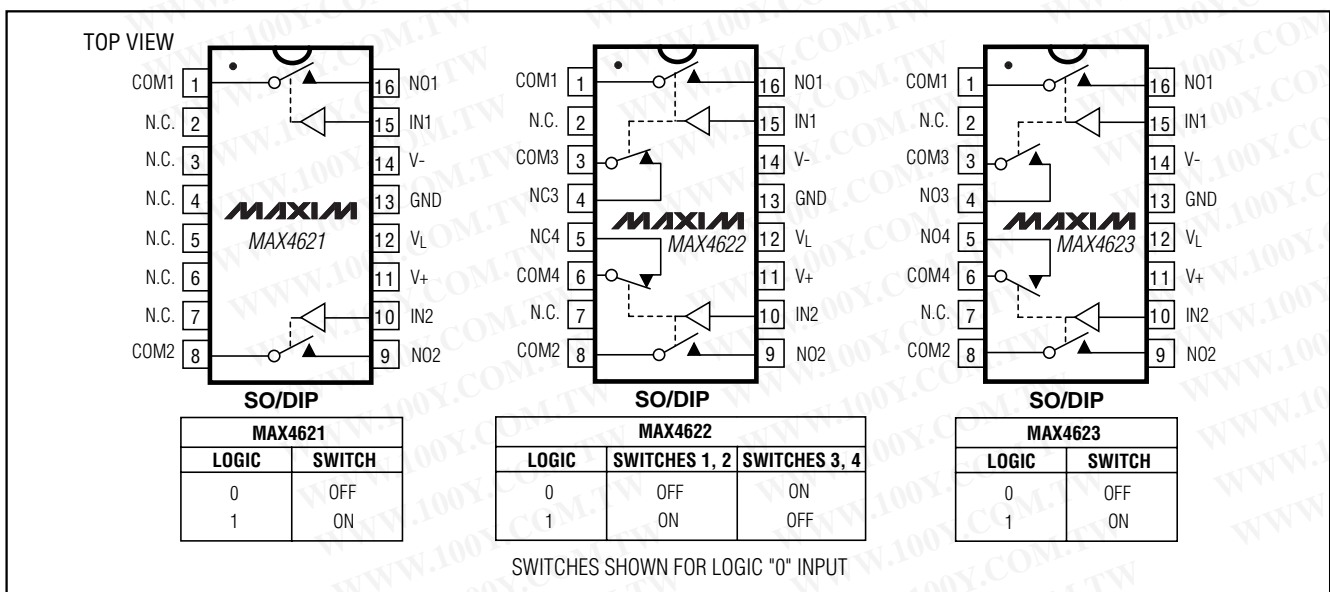

MAXIM

Maxim Integrated Products 1

For free samples & the latest literature: <http://www.maxim-ic.com>, or phone 1-800-998-8800.
 For small orders, phone 1-800-835-8769.

Dual, 5Ω Analog Switches

ABSOLUTE MAXIMUM RATINGS

(Voltages Referenced to GND)

V+ to GND	-0.3V to +44V
V- to GND	+0.3V to -44V
V+ to V-	-0.3V to +44V
V _L to GND	-0.3V to (V+ + 0.3V)
All Other Pins to GND (Note 1)	(V- - 0.3V) to (V+ + 0.3V)
Continuous Current (COM ₋ , NO ₋ , NC ₋)	±100mA
Peak Current (COM ₋ , NO ₋ , NC ₋) (pulsed at 1ms, 10% duty cycle)	±300mA

Continuous Power Dissipation (T_A = +70°C)

Narrow SO (derate 8.70mW/°C above +70°C)	696mW
Narrow DIP (derate 10.53mW/°C above +70°C)	842mW

Operating Temperature Ranges

MAX462_C_	0°C to +70°C
MAX462_E_	-40°C to +85°C
Storage Temperature Range	-65°C to +150°C
Lead Temperature (soldering, 10sec)	+300°C

Note 1: Signals on NO₋, NC₋, or COM₋ exceeding V+ or V- are clamped by internal diodes. Limit forward-diode current to maximum current rating.

Stresses beyond those listed under "Absolute Maximum Ratings" may cause permanent damage to the device. These are stress ratings only, and functional operation of the device at these or any other conditions beyond those indicated in the operational sections of the specifications is not implied. Exposure to absolute maximum rating conditions for extended periods may affect device reliability.

ELECTRICAL CHARACTERISTICS—Dual Supplies

(V+ = +15V, V- = -15V, V_L = +5V, GND = 0, V_{INH} = +2.4V, V_{INL} = +0.8V, T_A = T_{MIN} to T_{MAX}, unless otherwise noted. Typical values are at T_A = +25°C.) (Note 2)

PARAMETER	SYMBOL	CONDITIONS	MIN	TYP	MAX	UNITS	
ANALOG SWITCH							
Input Voltage Range (Note 3)	V _{COM-} , V _{NO-} , V _{NC-}		V-		V+	V	
On-Resistance	R _{ON}	I _{COM-} = 10mA, V _{NO-} or V _{NC-} = ±10V		3	5	Ω	
			T _A = +25°C				
			T _A = T _{MIN} to T _{MAX}		7		
On-Resistance Match Between Channels (Notes 3, 4)	ΔR _{ON}	I _{COM-} = 10mA, V _{NO-} or V _{NC-} = ±10V		0.25	0.5	Ω	
			T _A = +25°C				
			T _A = T _{MIN} to T _{MAX}		0.7		
On-Resistance Flatness (Notes 3, 5)	R _{FLAT(ON)}	I _{COM-} = 10mA; V _{NO-} or V _{NC-} = -5V, 0, 5V		0.2	0.5	Ω	
			T _A = +25°C				
			T _A = T _{MIN} to T _{MAX}		0.7		
Off-Leakage Current (NO ₋ or NC ₋) (Note 6)	I _{NO-} , I _{NC-}	V _{NO-} or V _{NC-} = ±10V, V _{COM-} = ∓10V		-0.5	0.01	0.5	nA
			T _A = +25°C				
			T _A = T _{MIN} to T _{MAX}	-5		5	
COM ₋ Off-Leakage Current (Note 6)	I _{COM-(OFF)}	V _{COM-} = ±10V, V _{NO-} or V _{NC-} = ∓10V		-0.5	0.01	0.5	nA
			T _A = +25°C				
			T _A = T _{MIN} to T _{MAX}	-5		5	
COM ₋ On-Leakage Current (Note 6)	I _{COM-(ON)}	V _{COM-} = ±10V, V _{NO-} or V _{NC-} = ∓10V or floating		-1	0.02	1	nA
			T _A = +25°C				
			T _A = T _{MIN} to T _{MAX}	-10		10	
LOGIC INPUT							
Input Current with Input Voltage High	I _{INH}	V _{IN-} = 2.4V	-0.5	0.001	0.5	μA	
Input Current with Input Voltage Low	I _{INL}	V _{IN-} = 0.8V	-0.5	0.001	0.5	μA	
Logic Input Voltage High	V _{INH}		2.4			V	
Logic Input Voltage Low	V _{INL}				0.8	V	

Dual, 5Ω Analog Switches

ELECTRICAL CHARACTERISTICS—Dual Supplies (continued)

(V+ = +15V, V- = -15V, VL = +5V, GND = 0, VINH = +2.4V, VINL = +0.8V, TA = TMIN to TMAX, unless otherwise noted. Typical values are at TA = +25°C.) (Note 2)

PARAMETER	SYMBOL	CONDITIONS		MIN	TYP	MAX	UNITS
POWER SUPPLY							
Power-Supply Range				±4.5		±20.0	V
Positive Supply Current	I+	VIN_ = 0 or 5V	TA = +25°C	-0.5	0.001	0.5	μA
			TA = TMIN to TMAX	-5		5	
Negative Supply Current	I-	VIN_ = 0 or 5V	TA = +25°C	-0.5	0.001	0.5	μA
			TA = TMIN to TMAX	-5		5	
Logic Supply Current	IL	VIN_ = 0 or 5V	TA = +25°C	-0.5	0.001	0.5	μA
			TA = TMIN to TMAX	-5		5	
Ground Current	IGND	VIN_ = 0 or 5V	TA = +25°C	-0.5	0.001	0.5	μA
			TA = TMIN to TMAX	-5		5	
SWITCH DYNAMIC CHARACTERISTICS							
Turn-On Time	tON	VCOM_ = ±10V, Figure 2	TA = +25°C		120	250	ns
			TA = TMIN to TMAX			325	
Turn-Off Time	tOFF	VCOM_ = ±10V, Figure 2	TA = +25°C		90	200	ns
			TA = TMIN to TMAX			275	
Break-Before-Make Time Delay (MAX4622 only)	tD	VCOM_ = ±10V, Figure 3, TA = +25°C		5	25		ns
Charge Injection	Q	CL = 1.0nF, VGEN = 0, RGEN = 0, Figure 4, TA = +25°C			480		pC
Off-Isolation (Note 7)	VISO	RL = 50Ω, f = 1MHz, Figure 5, TA = +25°C			-62		dB
Crosstalk (Note 8)	VCT	RL = 50Ω, f = 1MHz, Figure 6, TA = +25°C			-60		dB
NC_ or NO_ Capacitance	COFF	f = 1MHz, Figure 7, TA = +25°C			34		pF
COM_ Off-Capacitance	CCOM	f = 1MHz, Figure 7, TA = +25°C			34		pF
On-Capacitance	CCOM	f = 1MHz, Figure 8, TA = +25°C			150		pF

MAX4621/MAX4622/MAX4623

Dual, 5Ω Analog Switches

ELECTRICAL CHARACTERISTICS—Single Supply

(V+ = +12V, V- = 0, VL = +5V, GND = 0, VINH = +2.4V, VINL = +0.8V, TA = TMIN to TMAX, unless otherwise noted. Typical values are TA = +25°C.) (Note 2)

PARAMETER	SYMBOL	CONDITIONS	MIN	TYP	MAX	UNITS	
ANALOG SWITCH							
Input Voltage Range (Note 3)	VCOM_, VNO_, VNC_		GND		V+	V	
On-Resistance	RON	ICOM_ = 10mA, VNO_ or VNC_ = 10V	TA = +25°C	5.5	8	Ω	
			TA = TMIN to TMAX		10		
On-Resistance Match Between Channels (Notes 3, 4)	ΔRON	ICOM_ = 10mA, VNO_ or VNC_ = 10V, TA = +25°C		0.2	0.5	Ω	
On-Resistance Flatness (Notes 3, 5)	RFLAT(ON)	ICOM_ = 10mA; VNO_ or VNC_ = 3V, 6V, 9V; TA = +25°C		0.9	1.3	Ω	
NO_ or NC_ Off-Leakage Current (Notes 6, 9)	INO_(OFF), INC_(OFF)	VCOM_ = 1V, 10V; VNO_ or VNC_ = 10V, 1V	TA = +25°C	-0.5	0.01	0.5	nA
			TA = TMIN to TMAX	-5		5	
COM_ Off-Leakage Current (Notes 6, 9)	ICOM_(OFF)	VCOM_ = 10V, 1V; VNO_ or VNC_ = 1V, 10V	TA = +25°C	-0.5	0.01	0.5	nA
			TA = TMIN to TMAX	-5		5	
COM_ On-Leakage Current (Notes 6, 9)	ICOM_(ON)	VCOM_ = 10V, 1V; VNO_ or VNC_ = 10V, 1V, or floating	TA = +25°C	-1	0.02	1	nA
			TA = TMIN to TMAX	-10		10	
LOGIC INPUT							
Input Current with Input Voltage High	IINH	VIN_ = 2.4V	-0.5	0.001	0.5	μA	
Input Current with Input Voltage Low	IINL	VIN_ = 0.8V	-0.5	0.001	0.5	μA	
Logic Input Voltage High	VINH		2.4			V	
Logic Input Voltage Low	VINL				0.8	V	
POWER SUPPLY							
Power-Supply Range			4.5		36.0	V	
Positive Supply Current	I+	VIN_ = 0 or 5V	TA = +25°C	-0.5	0.001	0.5	μA
			TA = TMIN to TMAX	-5		5	
Logic Supply Current	IL	VIN_ = 0 or 5V	TA = +25°C	-0.5	0.001	0.5	μA
			TA = TMIN to TMAX	-5		5	
Ground Current	IGND	VIN_ = 0 or 5V	TA = +25°C	-0.5	0.001	0.5	μA
			TA = TMIN to TMAX	-5		5	

Dual, 5Ω Analog Switches

ELECTRICAL CHARACTERISTICS—Single Supply (continued)

(V+ = +12V, V- = 0, VL = +5V, GND = 0, VINH = +2.4V, VINL = +0.8V, TA = TMIN to TMAX, unless otherwise noted. Typical values are TA = +25°C.) (Note 2)

PARAMETER	SYMBOL	CONDITIONS	MIN	TYP	MAX	UNITS
SWITCH DYNAMIC CHARACTERISTICS						
Turn-On Time (Note 3)	tON	VCOM_ = 10V, Figure 2	TA = +25°C	200	350	ns
			TA = TMIN to TMAX		475	
Turn-Off Time (Note 3)	tOFF	VCOM_ = 10V, Figure 2	TA = +25°C	100	200	ns
			TA = TMIN to TMAX		300	
Break-Before-Make Time Delay (MAX4622 only) (Note 3)	tD	RL = 100Ω, CL = 35pF, Figure 3, TA = +25°C	10	75		ns
Charge Injection	Q	CL = 1.0nF, VGEN = 0, RGEN = 0, Figure 4		45		pC
Off-Isolation (Note 7)	VISO	RL = 50Ω, f = 1MHz, Figure 5		-62		dB
Crosstalk (Note 8)	VCT	RL = 50Ω, f = 1MHz, Figure 6		-60		dB

Note 2: The algebraic convention, where the most negative value is a minimum and the most positive value is a maximum, is used in this data sheet.

Note 3: Guaranteed by design.

Note 4: $\Delta R_{ON} = R_{ON_MAX} - R_{ON_MIN}$.

Note 5: Flatness is defined as the difference between the maximum and minimum values of on-resistance as measured over the specified analog signal range.

Note 6: Leakage currents are 100% tested at the maximum-rated hot temperature and guaranteed by correlation at +25°C.

Note 7: Off-isolation = $20\log_{10} [V_{COM_} / (V_{NC_} \text{ or } V_{NO_})]$. VCOM_ = output, VNC_ or VNO_ = input to off switch.

Note 8: Between any two switches.

Note 9: Leakage testing for single-supply operation is guaranteed by testing with dual supplies.

MAX4621/MAX4622/MAX4623

Dual, 5Ω Analog Switches

Typical Operating Characteristics

($T_A = +25^\circ\text{C}$, unless otherwise noted.)

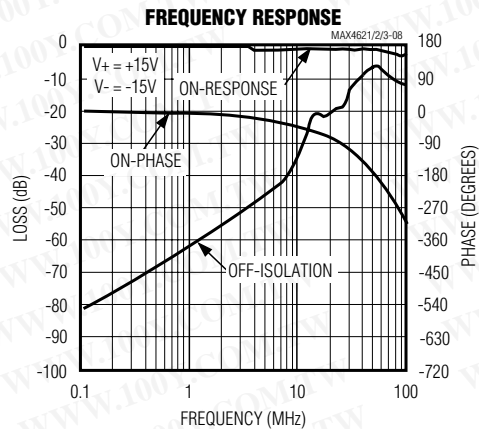
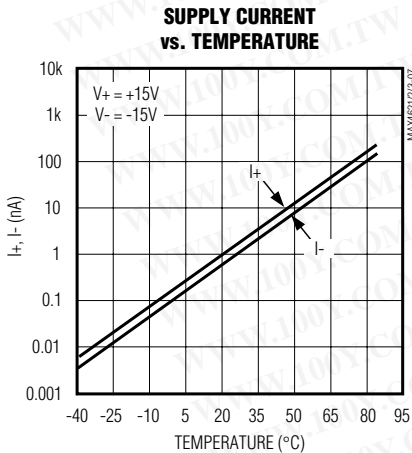
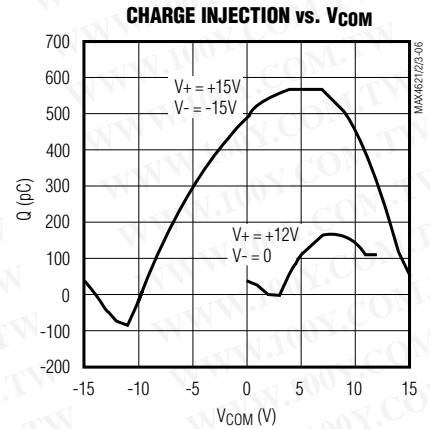
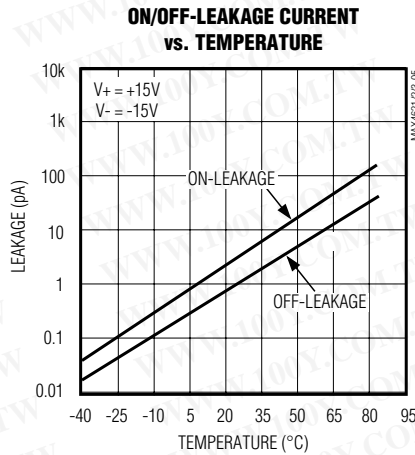
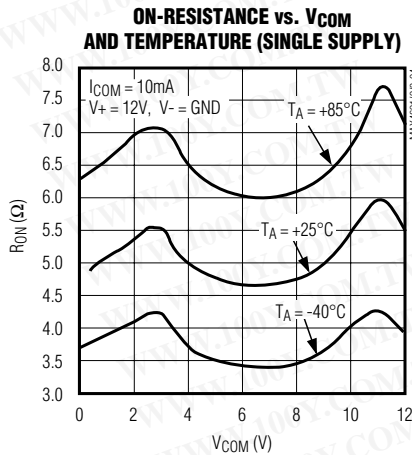
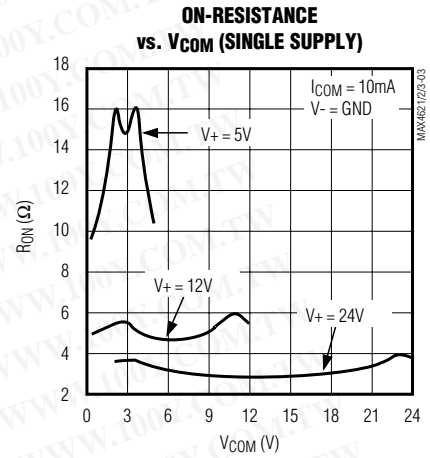
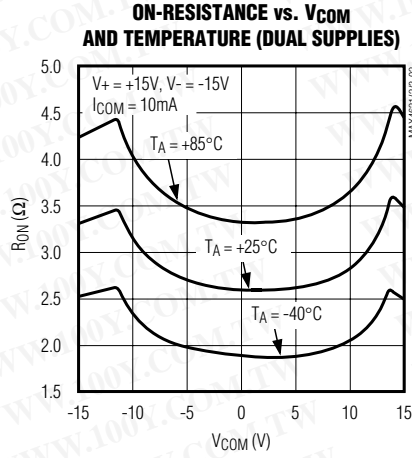
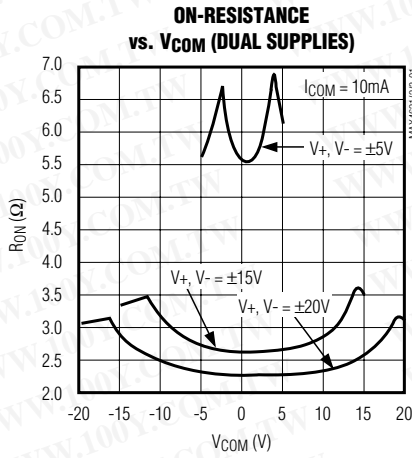

Dual, 5Ω Analog Switches

MAX4621/MAX4622/MAX4623

Pin Description

PIN	NAME	FUNCTION
MAX4621		
1, 8	COM1, COM2	Switch Common Terminal
2–7	N.C.	Not internally connected
9, 16	NO2, NO1	Switch Normally Open Terminal
10, 15	IN2, IN1	Digital Logic Inputs
11	V+	Positive Supply-Voltage Input
12	V _L	Logic Supply-Voltage Input
13	GND	Ground
14	V-	Negative Supply Voltage Input
MAX4622		
1, 3, 6, 8	COM ₋	Switch Common Terminal
2, 7	N.C.	Not internally connected
4, 5, 9, 16	NC ₋ , NO ₋	Switch Normally Closed/Open Terminal
10, 15	IN2, IN1	Digital Logic Inputs
11	V+	Positive Supply-Voltage Input
12	V _L	Logic Supply-Voltage Input
13	GND	Ground
14	V-	Negative Supply Voltage Input
MAX4623		
1, 3, 6, 8	COM ₋	Switch Common Terminal
2, 7	N.C.	Not internally connected
4, 5, 9, 16	NO ₋	Switch Normally Open Terminal
10, 15	IN2, IN1	Digital Logic Inputs
11	V+	Positive Supply-Voltage Input
12	V _L	Logic Supply-Voltage Input
13	GND	Ground
14	V-	Negative Supply Voltage

Applications Information

Operation with Supply Voltages Other than ±15V

The MAX4621/MAX4622/MAX4623 switches operate with ±4.5V to ±18V bipolar supplies and a +4.5V to +36V single supply. In either case, analog signals ranging from V₊ to V₋ can be switched. The *Typical Operating Characteristics* graphs show the typical on-resistance variation with analog signal and supply voltage.

Overvoltage Protection

Proper power-supply sequencing is recommended for all CMOS devices. It is important not to exceed the absolute maximum ratings because stresses beyond the listed ratings may cause permanent damage to the devices. Always sequence V₊ on first, followed by V_L, V₋, and logic inputs. If power-supply sequencing is not possible, add two small signal diodes in series with the supply pins and a Schottky diode between V₊ and V_L (Figure 1). Adding diodes reduces the analog signal range to 1V below V₊ and 1V above V₋, but low switch resistance and low leakage characteristics are unaffected. The difference between V₊ and V₋ should not exceed +44V.

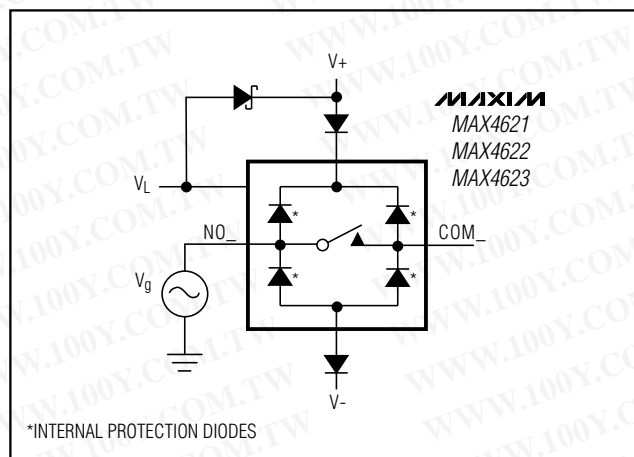

Figure 1. Overvoltage Protection Using Blocking Diodes

Dual, 5Ω Analog Switches

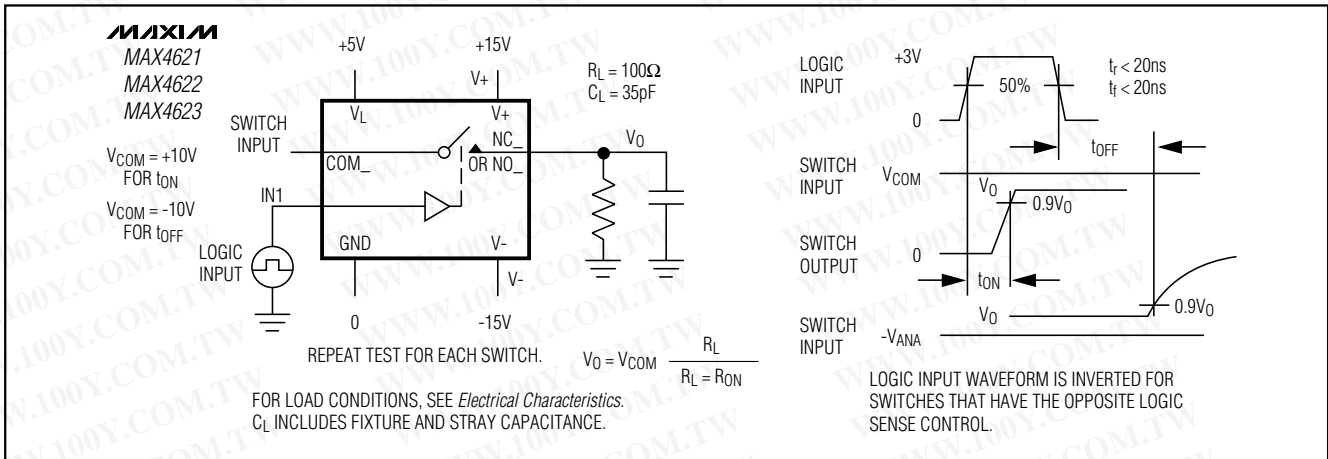

Figure 2. Switching-Time Test Circuit

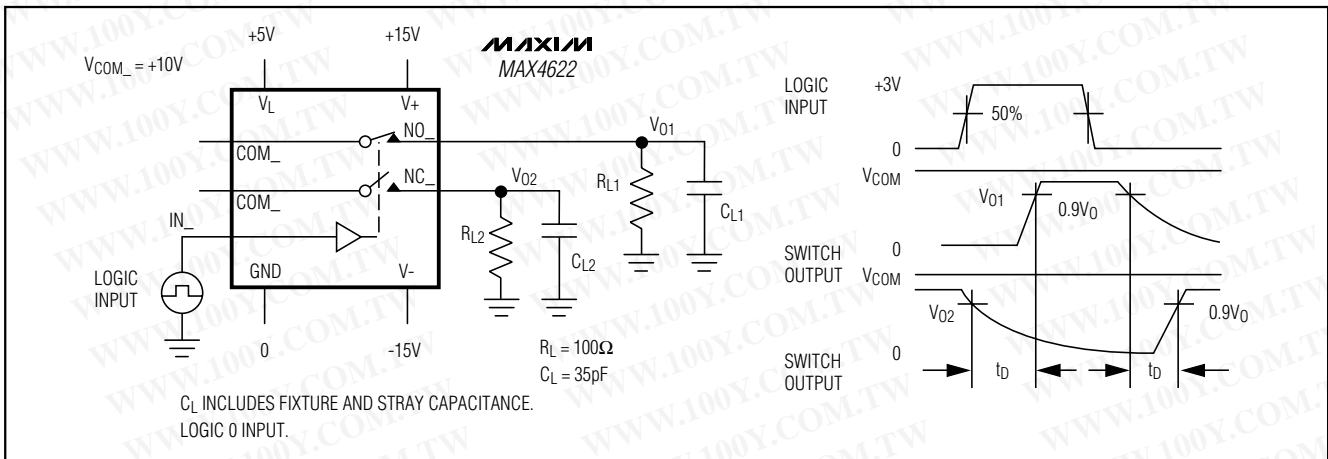

Figure 3. MAX4622 Break-Before-Make Test Circuit

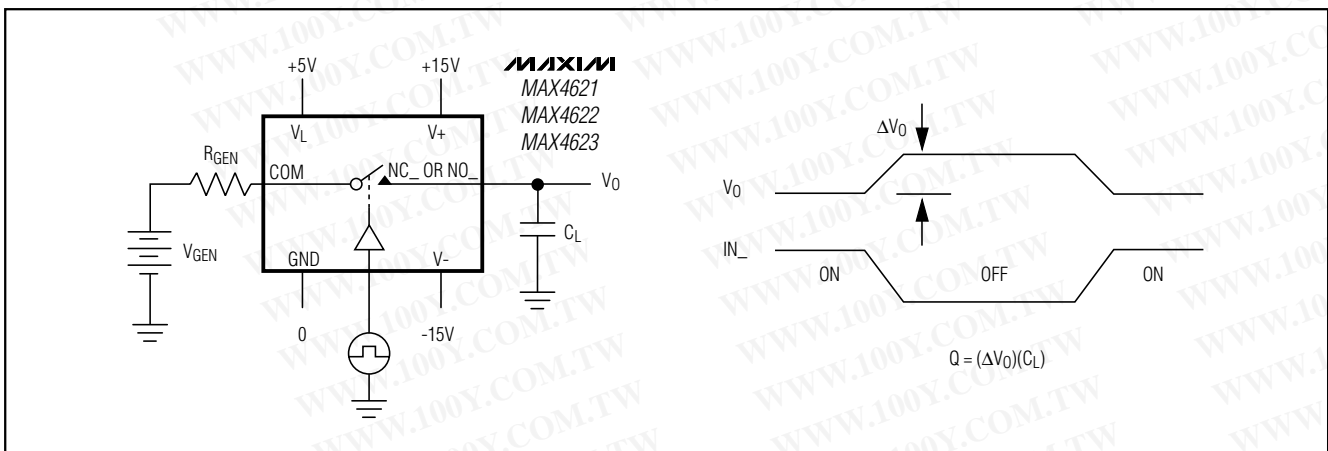

Figure 4. Charge-Injection Test Circuit

Dual, 5Ω Analog Switches

MAX4621/MAX4622/MAX4623

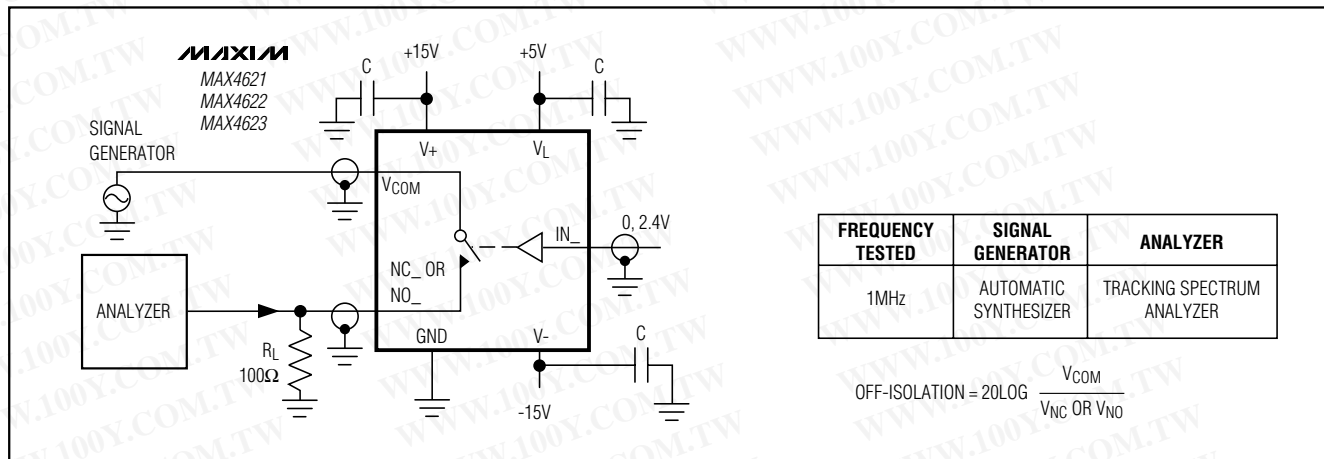

Figure 5. Off-Isolation

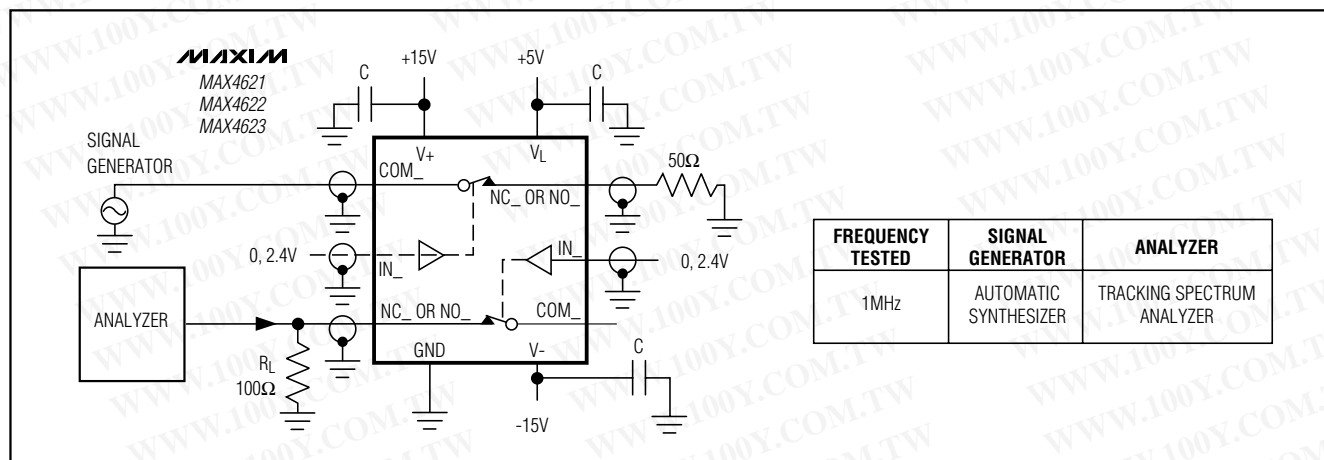

Figure 6. Crosstalk Test Circuit

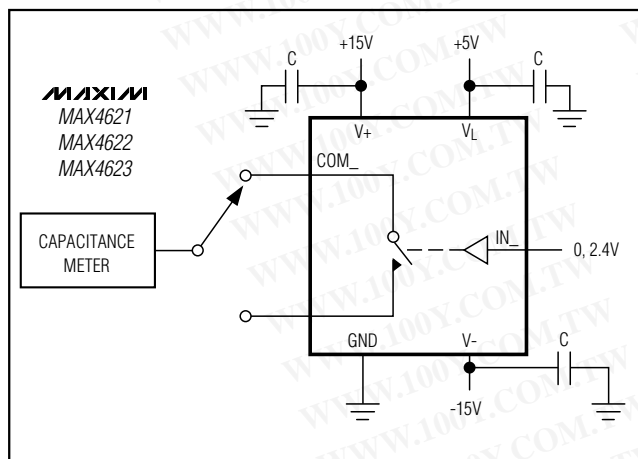

Figure 7. Channel-On Capacitance

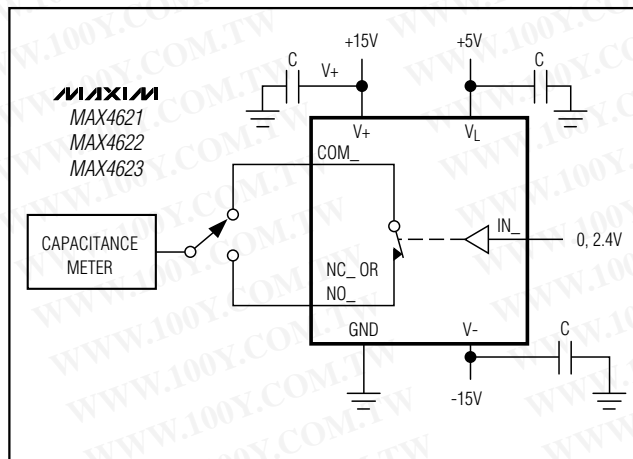

Figure 8. Channel-Off Capacitance

Dual, 5Ω Analog Switches

Ordering Information (continued)

PART	TEMP. RANGE	PIN-PACKAGE
MAX4621ESE	-40°C to +85°C	16 Narrow SO
MAX4621EPE	-40°C to +85°C	16 Plastic DIP
MAX4622CSE	0°C to +70°C	16 Narrow SO
MAX4622CPE	0°C to +70°C	16 Plastic DIP
MAX4622ESE	-40°C to +85°C	16 Narrow SO
MAX4622EPE	-40°C to +85°C	16 Plastic DIP
MAX4623CSE	0°C to +70°C	16 Narrow SO
MAX4623CPE	0°C to +70°C	16 Plastic DIP
MAX4623ESE	-40°C to +85°C	16 Narrow SO
MAX4623EPE	-40°C to +85°C	16 Plastic DIP

Chip Information

TRANSISTOR COUNT: 82

Package Information

	INCHES		MILLIMETERS	
	MIN	MAX	MIN	MAX
A	0.053	0.069	1.35	1.75
A1	0.004	0.010	0.10	0.25
B	0.014	0.019	0.35	0.49
C	0.007	0.010	0.19	0.25
e	0.050		1.27	
E	0.150	0.157	3.80	4.00
H	0.228	0.244	5.80	6.20
h	0.010	0.020	0.25	0.50
L	0.016	0.050	0.40	1.27

	INCHES		MILLIMETERS		N	MS012
	MIN	MAX	MIN	MAX		
D	0.189	0.197	4.80	5.00	8	A
D	0.337	0.344	8.55	8.75	14	B
D	0.386	0.394	9.80	10.00	16	C

NOTES:
 1. D&E DO NOT INCLUDE MOLD FLASH
 2. MOLD FLASH OR PROTRUSIONS NOT TO EXCEED .15mm (.006")
 3. LEADS TO BE COPLANAR WITHIN .102mm (.004")
 4. CONTROLLING DIMENSION: MILLIMETER
 5. MEETS JEDEC MS012-XX AS SHOWN IN ABOVE TABLE
 6. N = NUMBER OF PINS

MAXIM
 IN AN AREA OF SIMILAR TO THIS, FAX AND TO 774
 PROPRIETARY INFORMATION

PACKAGE FAMILY OUTLINE: SOIC .150" 1/1 21-0041 A
 DOCUMENT CONTROL NUMBER REV

Dual, 5Ω Analog Switches

Package Information (continued)

MAX4621/MAX4622/MAX4623

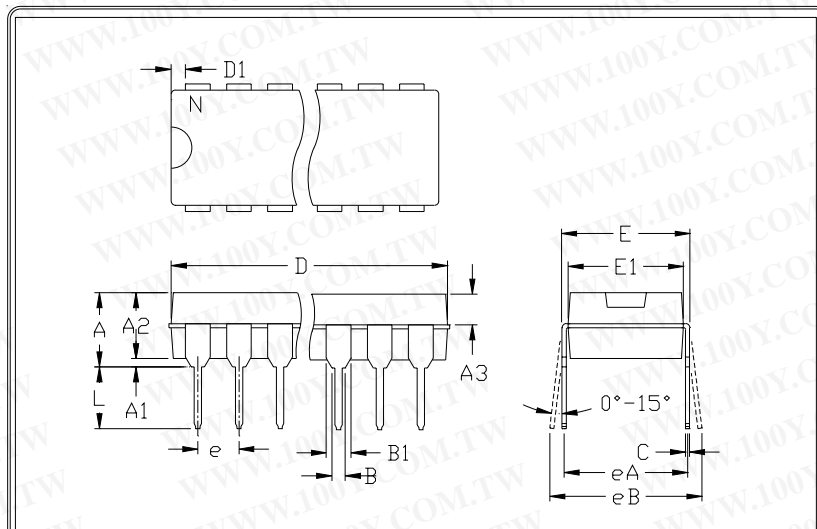

	INCHES		MILLIMETERS	
	MIN	MAX	MIN	MAX
A	---	0.200	---	5.08
A1	0.015	---	0.38	---
A2	0.125	0.175	3.18	4.45
A3	0.055	0.080	1.40	2.03
B	0.016	0.022	0.41	0.56
B1	0.045	0.065	1.14	1.65
C	0.008	0.012	0.20	0.30
D1	0.005	0.080	0.13	2.03
E	0.300	0.325	7.62	8.26
E1	0.240	0.310	6.10	7.87
e	0.100	---	2.54	---
eA	0.300	---	7.62	---
eB	---	0.400	---	10.16
L	0.115	0.150	2.92	3.81

	INCHES		MILLIMETERS		N	MS001
	MIN	MAX	MIN	MAX		
D	0.348	0.390	8.84	9.91	8	AB
D	0.735	0.765	18.67	19.43	14	AC
D	0.745	0.765	18.92	19.43	16	AA
D	0.885	0.915	22.48	23.24	18	AD
D	1.015	1.045	25.78	26.54	20	AE
D	1.14	1.265	28.96	32.13	24	AF
D	1.360	1.380	34.54	35.05	28	*5

- NOTES:
1. D&E DO NOT INCLUDE MOLD FLASH
 2. MOLD FLASH OR PROTRUSIONS NOT TO EXCEED .15mm (.006")
 3. CONTROLLING DIMENSION: MILLIMETER
 4. MEETS JEDEC MS001-XX AS SHOWN IN ABOVE TABLE
 5. SIMILAR TO JEDEC MO-058B
 6. N = NUMBER OF PINS

 PACKAGE FAMILY OUTLINE: PDIP .300" 1/1 21-0043 A
101 SAN CARLOS, DR. SAN JOSE, CA 95050. FAX (408) 737-7700 TITLE DOCUMENT CONTROL NUMBER REV

Dual, 5Ω Analog Switches

NOTES

勝特力材料 886-3-5753170
勝特力电子(上海) 86-21-34970699
勝特力电子(深圳) 86-755-83298787
[Http://www.100y.com.tw](http://www.100y.com.tw)

Maxim cannot assume responsibility for use of any circuitry other than circuitry entirely embodied in a Maxim product. No circuit patent licenses are implied. Maxim reserves the right to change the circuitry and specifications without notice at any time.

12 _____ **Maxim Integrated Products, 120 San Gabriel Drive, Sunnyvale, CA 94086 408-737-7600**