



Precision, Quad, SPDT, CMOS Analog Switch

MAX333A

General Description

The MAX333A is a precision, quad, single-pole double-throw (SPDT) analog switch. The four independent switches operate with bipolar supplies ranging from $\pm 4.5\text{V}$ to $\pm 20\text{V}$, or with a single-ended supply between $+10\text{V}$ and $+30\text{V}$. The MAX333A offers low on resistance (less than 35Ω), guaranteed to match within 2Ω between channels and to remain flat over the analog signal range ($\Delta 3\Omega$ max). It also offers break-before-make switching (10ns typical), with turn-off times less than 145ns and turn-on times less than 175ns. The MAX333A is ideal for portable operation since quiescent current runs less than $50\mu\text{A}$ with all inputs high or low.

This monolithic, quad switch is fabricated with Maxim's new improved silicon-gate process. Design improvements guarantee extremely low charge injection (10pC), low power consumption (3.75mW), and electrostatic discharge (ESD) greater than 2000V.

Logic inputs are TTL and CMOS compatible and guaranteed over a $+0.8\text{V}$ to $+2.4\text{V}$ range—regardless of supply voltage. Logic inputs and switched analog signals can range anywhere between the supply voltages without damage.

Applications

Test Equipment
 Communications Systems
 PBX, PABX
 Heads-Up Displays
 Portable Instruments

Pin Configuration

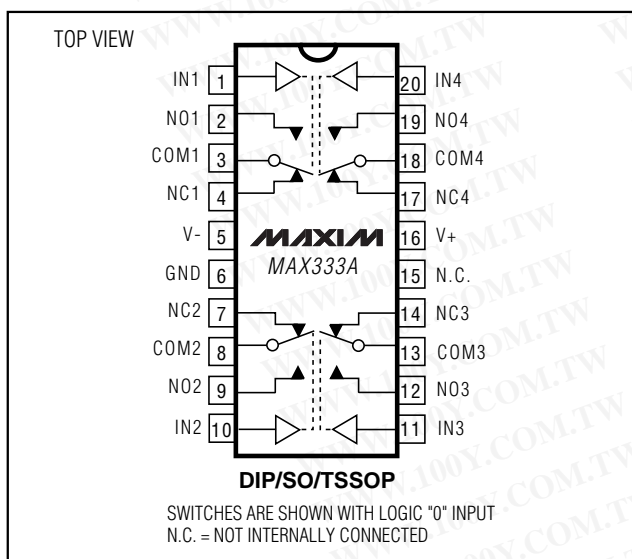

Features

- ◆ Upgraded Replacement for a DG211/DG212 Pair or Two DG403s
- ◆ Low On Resistance $< 17\Omega$ Typical (35Ω Max)
- ◆ Guaranteed Matched On Resistance Between Channels $< 2\Omega$
- ◆ Guaranteed Flat On Resistance over Analog Signal Range $\Delta 3\Omega$ Max
- ◆ Guaranteed Charge Injection $< 10\text{pC}$
- ◆ Guaranteed Off-Channel Leakage $< 6\text{nA}$ at $+85^\circ\text{C}$
- ◆ ESD Guaranteed $> 2000\text{V}$ per Method 3015.7
- ◆ Single-Supply Operation ($+10\text{V}$ to $+30\text{V}$)
 Bipolar-Supply Operation ($\pm 4.5\text{V}$ to $\pm 20\text{V}$)
- ◆ TTL-/CMOS-Logic Compatibility
- ◆ Rail-to-Rail Analog Signal Handling Capability

Ordering Information

PART	TEMP. RANGE	PIN-PACKAGE
MAX333ACPP	0°C to $+70^\circ\text{C}$	20 Plastic DIP
MAX333ACWP	0°C to $+70^\circ\text{C}$	20 Wide SO
MAX333ACUP	0°C to $+70^\circ\text{C}$	20 TSSOP
MAX333AC/D	0°C to $+70^\circ\text{C}$	Dice*
MAX333AEPP	-40°C to $+85^\circ\text{C}$	20 Plastic DIP
MAX333AEWP	-40°C to $+85^\circ\text{C}$	20 Wide SO
MAX333AEUP	-40°C to $+85^\circ\text{C}$	20 TSSOP
MAX333AMJP	-55°C to $+125^\circ\text{C}$	20 CERDIP

* Contact factory for dice specifications.

Typical Operating Circuit

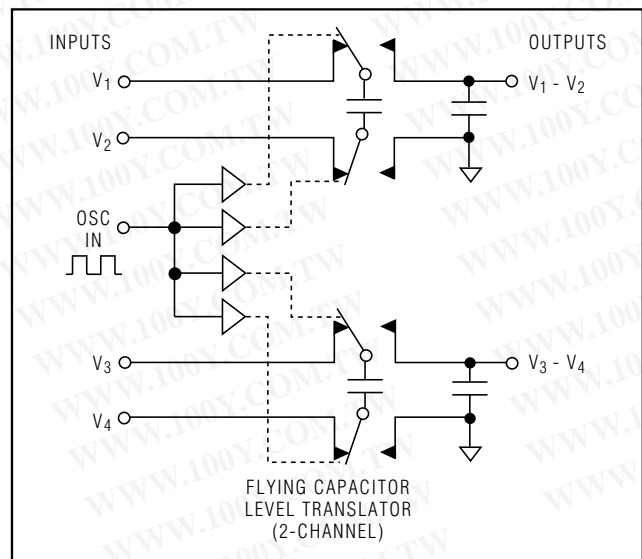

Precision, Quad, SPDT, CMOS Analog Switch

ABSOLUTE MAXIMUM RATINGS

V+ to V-	44V
V _{IN} , V _{COM} , V _{NO} , V _{NC}	V- to V+
(V _{NO} - V _{NC})	32V
V+ to Ground	30V
V- to Ground	30V
Current, Any Terminal Except V _{COM} , V _{NO} , or V _{NC}	30mA
Continuous Current, V _{COM} , V _{NO} , or V _{NC}	20mA
Peak Current, V _{COM} , V _{NO} , or V _{NC} (Pulsed at 1ms, 10% duty cycle max)	70mA
ESD	2000V

Continuous Power Dissipation (T _A = +70°C) (Note 1)	
Plastic DIP (derate above +70°C by 11.11mW/°C)	889mW
SO (derate above +70°C by 10.00mW/°C)	800mW
CERDIP (derate above +70°C by 11.11mW/°C)	889mW
TSSOP (derate above +70°C by 7mW/°C)	559mW
Operating Temperature Ranges:	
MAX333AC	0°C to +70°C
MAX333AE	-40°C to +85°C
MAX333AMJP	-55°C to +125°C
Storage Temperature Range	-65°C to +150°C
Lead Temperature (soldering, 10sec)	+300°C

Note 1: Device mounted with all leads soldered to PC board.

Stresses beyond those listed under "Absolute Maximum Ratings" may cause permanent damage to the device. These are stress ratings only, and functional operation of the device at these or any other conditions beyond those indicated in the operational sections of the specifications is not implied. Exposure to absolute maximum rating conditions for extended periods may affect device reliability.

ELECTRICAL CHARACTERISTICS—Dual Supplies

(GND = 0V, V+ = +15V, V- = -15V, T_A = +25°C, unless otherwise noted.)

PARAMETER	SYMBOL	CONDITIONS	MIN	TYP (Notes 2, 3)	MAX	UNITS	
POWER REQUIREMENTS							
Positive Supply Current	I+	V _{IN} = 0V/5V, V+ = 16.5V, V- = -16.5V		0.05	0.25	mA	
Supply Voltage Range	V+/V-	Dual supply, V+ = V-	±4.5V		±20	V	
	V+	Single supply, V- = GND	10		30		
Negative Supply Current	I-	V _{IN} = 0V/5V, V+ = 16.5V, V- = -16.5V		0.01	1	µA	
LOGIC INPUT							
Input Voltage Low	V _{IL}		V-		0.8	V	
Input Voltage High	V _{IH}		2.4		V+	V	
Input Current	I _{IN}	V _{IN} = V-, V+	-1.0	0.0001	1.0	µA	
SWITCH							
Analog Signal Range	V _{COM} , V _{NO} , V _{NC}		V-		V+	V	
On Circuit Resistance	R _{ON}	V _{COM} = +10V, I _(NC or NO) = 1mA; V _{COM} = -10V, I _(NC or NO) = 1mA	M	20	35	Ω	
			C, E	45			
On Resistance Match Between Channels (Note 4)	R _{ON}	I _(NC or NO) = -10mA, V _D = 10V or -10V, V+ = 15V, V- = -15V	T _A = +25°C		2	Ω	
			T _A = T _{MIN} to T _{MAX}		4		
On Resistance Flatness (Note 4)	R _{ON}	I _(NC or NO) = -10mA, V _D = 5V or -5V, V+ = 15V, V- = -15V	T _A = +25°C		3	Ω	
			T _A = T _{MIN} to T _{MAX}		5		
On Circuit Leakage Current	I _{COM}	V _{COM} = ±15.5V, V _{NC} or V _{NO} = +15.5V, V+ = 16.5V, V- = -16.5V	M	-0.75	0.75	nA	
			C, E	-1.00	0.20		1.00
Off Circuit Leakage Current	I _{NC} or I _{NO}	V _{COM} = ±15.5V, V _{NC} or V _{NO} = +15.5V, V+ = 16.5V, V- = -16.5V	M	-0.25	0.01	0.25	nA
			C, E	-0.50	0.02	0.05	
DYNAMIC							
Turn-Off Time	t _{OFF}	Figure 1			145	ns	
Turn-On Time	t _{ON}				175	ns	
Break-Before-Make Time	t _{OPEN}		10			ns	
Off Capacitance	C _{OFF}			5		pF	
On Capacitance	C _{ON}			5		pF	
Charge Injection	Q	C _L = 10nF, V _{GEN} = 0V, R _{GEN} = 0Ω, Figure 6	T _A = +25°C		2	10	pC
Off Isolation	OIRR	f = 1MHz, R _L = 75Ω, V _{COM} = 2.3V _{RMS}			72		dB
Crosstalk	CCRR				78		dB

Precision, Quad, SPDT, CMOS Analog Switch

MAX333A

ELECTRICAL CHARACTERISTICS—DUAL SUPPLIES (continued)

(GND = 0V, V+ = +15V, V- = -15V, T_A = T_{MIN} to T_{MAX}, unless otherwise noted.)

PARAMETER	SYMBOL	CONDITIONS	MIN	TYP (Notes 2, 3)	MAX	UNITS
LOGIC INPUT						
Input Voltage Low	V _{IL}		V-		0.8	V
Input Voltage High	V _{IH}		2.4		V+	V
Input Current	I _{IN}	V _{IN} = V-, V+	-1.0	0.0001	1.0	μA
SWITCH						
Analog Signal Range	V _{COM}		V-		V+	V
On Circuit Resistance	R _{ON}	V _{COM} = 10V, I _(NC or NO) = 1mA; V _{COM} = -10V, I _(NC or NO) = 1mA	C, E		45	Ω
			M		45	
On Circuit Leakage Current	I _{COM}	V _{COM} = ±15V, V _{NC} or V _{NO} = -15V, V+ = 16.5V, V- = -16.5V	C, E	-10	10	nA
			M	-60	60	
On Circuit Leakage Current	I _{NC} or I _{NO}	V _{COM} = ±15V, V _{NC} or V _{NO} = -15V, V+ = 16.5V, V- = -16.5V	C, E	-6	6	nA
			M			

ELECTRICAL CHARACTERISTICS—Single Supply

(GND = 0V, V+ = +12V, V- = 0V, T_A = +25°C, unless otherwise noted.)

PARAMETER	SYMBOL	CONDITIONS	MIN	TYP (Notes 2, 3)	MAX	UNITS
SUPPLY						
Supply Voltage Range	V+	Single supply, V- = GND	10		30	V
Positive Supply Current	I+				0.25	mA
INPUT						
Input Voltage Low	V _{INLO}		0		0.8	V
Input Voltage High	V _{INHI}		2.4		V+	V
Input Current	I _{IN}	V _{IN} = V+, 0V			1	μA
SWITCH						
Analog Signal Range	V _{COM} , V _{NO} , V _{NC}		V-		V+	V
On Circuit Resistance	r _{ON}	V _{COM} = 10V, I _(NC or NO) = 1mA, V _{COM} = 1V, I _(NC or NO) = 1mA		35	75	Ω
On Circuit Leakage Current	I _{COM}	V _{COM} = 11V, V _{NC} or V _{NO} = 0V V _{COM} = 1V, V _{NC} or V _{NO} = V+			0.75	nA
Off Circuit Leakage Current	I _{NC} or I _{NO}	V _{COM} = 11V V _{NC} or V _{NO} = 1V			0.25	nA
DYNAMIC						
Turn-Off Time	t _{OFF}	Figure 1		45		ns
Turn-On Time	t _{ON}			90		ns
Break-Before-Make Time	t _{OPEN}		5	10		ns
Off Isolation	OIRR	f = 1MHz, R _L = 75Ω, V _{COM} = 2.3V _{RMS}		70		dB
Crosstalk	CCRR			72		dB

Note 2: The algebraic convention, whereby the most negative value is a minimum and the most positive is a maximum, is used in this data sheet.

Note 3: Typical values are for design aid only, not guaranteed or subject to production testing.

Note 4: On resistance match between channels and flatness are guaranteed only with bipolar-supply operation.

Precision, Quad, SPDT, CMOS Analog Switch

Typical Operating Characteristics

($T_A = +25^\circ\text{C}$, unless otherwise noted).

ON RESISTANCE vs. V_{COM} AND POWER SUPPLY VOLTAGE

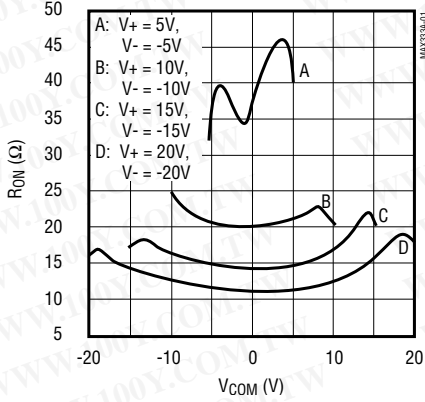

ON RESISTANCE vs. V_{COM} AND TEMPERATURE

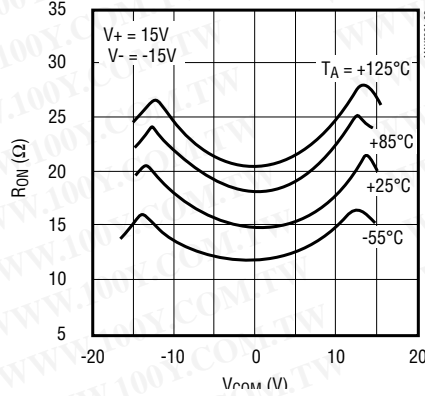

ON RESISTANCE vs. V_{COM} AND TEMPERATURE

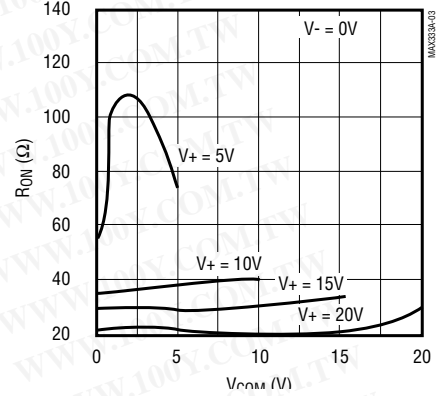

ON RESISTANCE vs. V_{COM} AND SINGLE SUPPLY

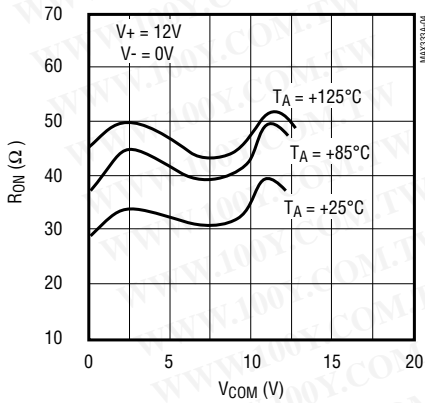

OFF LEAKAGE CURRENTS vs. TEMPERATURE

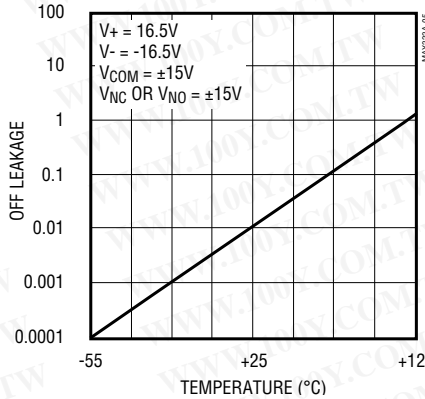

ON LEAKAGE CURRENTS vs. TEMPERATURE

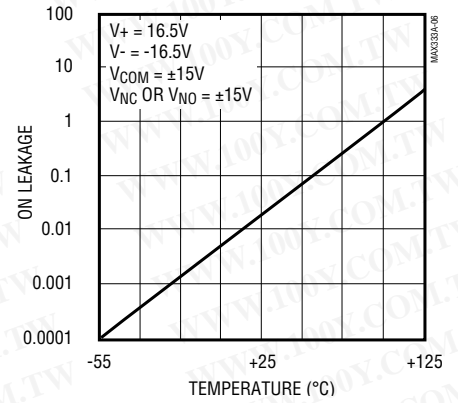

CHARGE INJECTION vs. V_{COM}

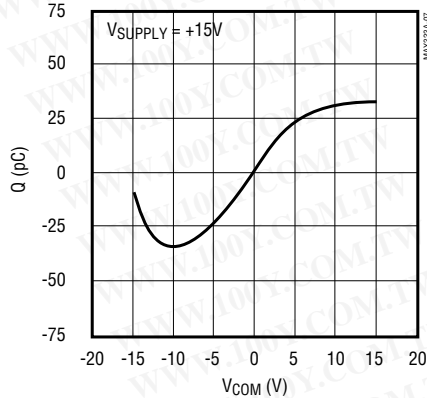

SUPPLY CURRENT vs. TEMPERATURE

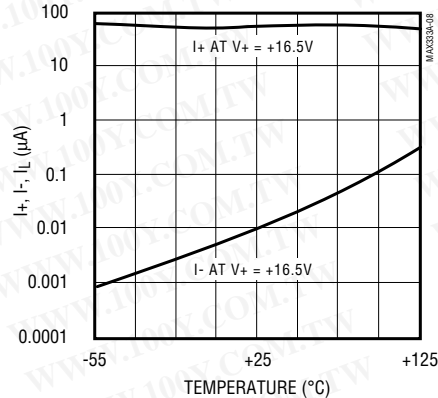

Precision, Quad, SPDT, CMOS Analog Switch

MAX333A

Pin Description

PIN	NAME	FUNCTION
1, 10, 11, 20	IN1-IN4	Logic-Level Inputs
2, 9, 12, 19	NO1-NO4	Normally Open Switches
3, 8, 13, 18	COM1-COM4	Common Switch Poles
4, 7, 14, 17	NC1-NC4	Normally Closed Switches
5	V-	Negative Power Supply
6	GND	Ground
15	N.C.	Not Internally Connected
16	V+	Positive Power Supply

Overvoltage Protection

Proper power-supply sequencing is recommended for all CMOS devices. It is important not to exceed the absolute maximum ratings because stresses beyond the listed ratings may cause permanent damage to the devices. Always sequence V+ on first, followed by VL, V-, and logic inputs. If power-supply sequencing is not possible, add two small signal diodes in series with the supply pins (Figure 1). Adding the diodes reduces the analog signal range to 1V below V+ and 1V below V-, but low switch resistance and low leakage characteristics are unaffected.

Applications Information

Operation with Supply Voltages Other than ±15V_o

The main limitation of supply voltages other than ±15V is a reduction in the analog signal range. The MAX333A operates with ±5V to ±20V bipolar supplies. The *Typical Operating Characteristics* and graphs show typical on resistance for ±15V, ±10V, ±5 supplies. Switching times increase by a factor of two or more for ±5V operation. The MAX333A can operate from +10V to +24V unipolar supplies. It can be powered from a single +10V to +24V supply, as well as from unbalanced supplies such as +24V and -5V. Connect V- to 0V when operating with a single supply.

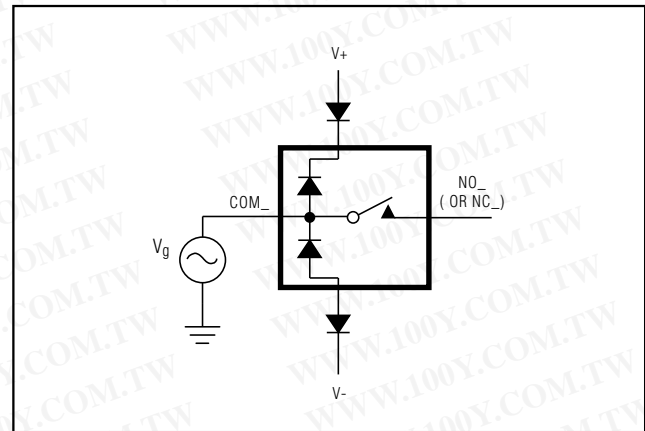

Figure 1. Overvoltage Protection Using Blocking Diodes

Test Circuits/Timing Diagrams

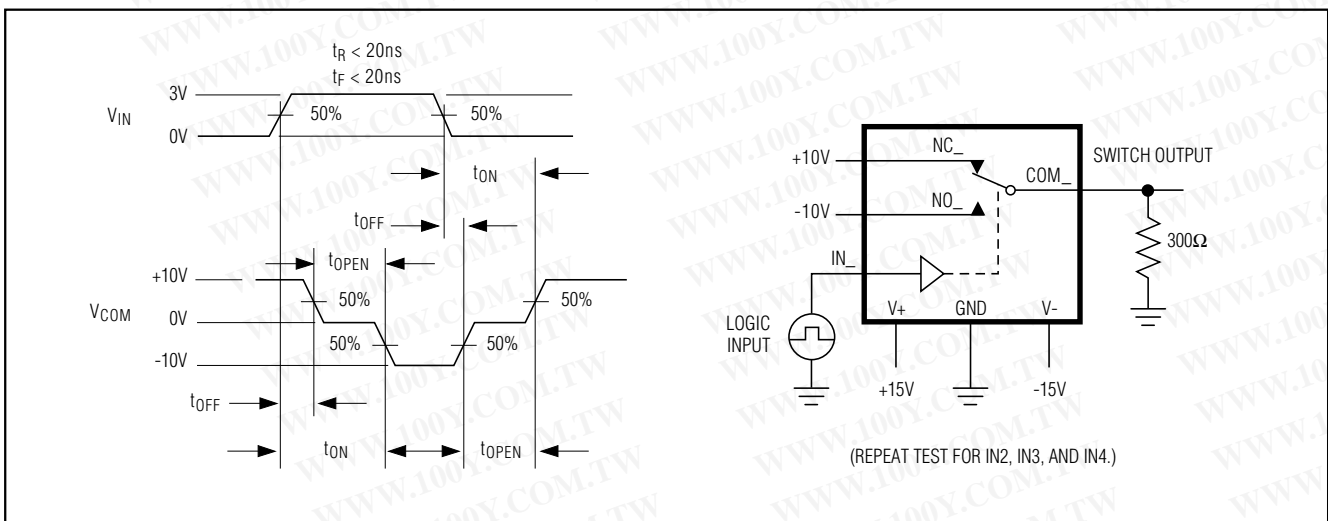

Figure 2. Switching-Time Test Circuit

Precision, Quad, SPDT, CMOS Analog Switch

Test Circuits/Timing Diagrams

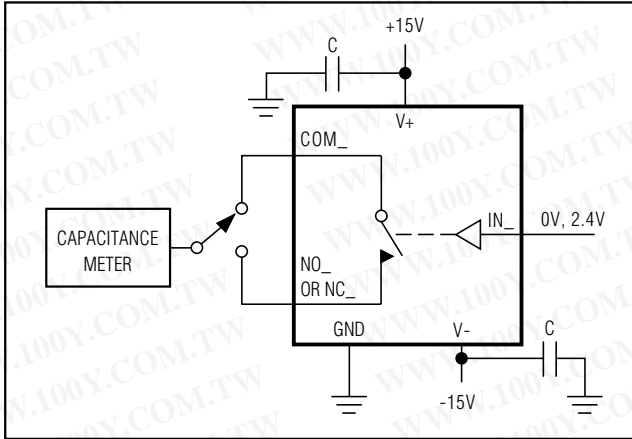

Figure 3. Channel-Off Capacitance

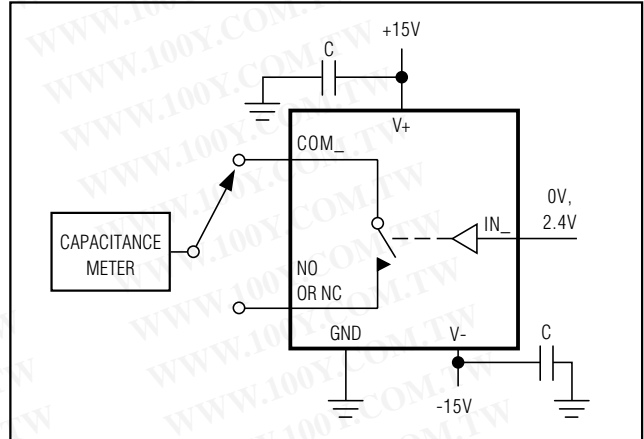

Figure 4. Channel-On Capacitance

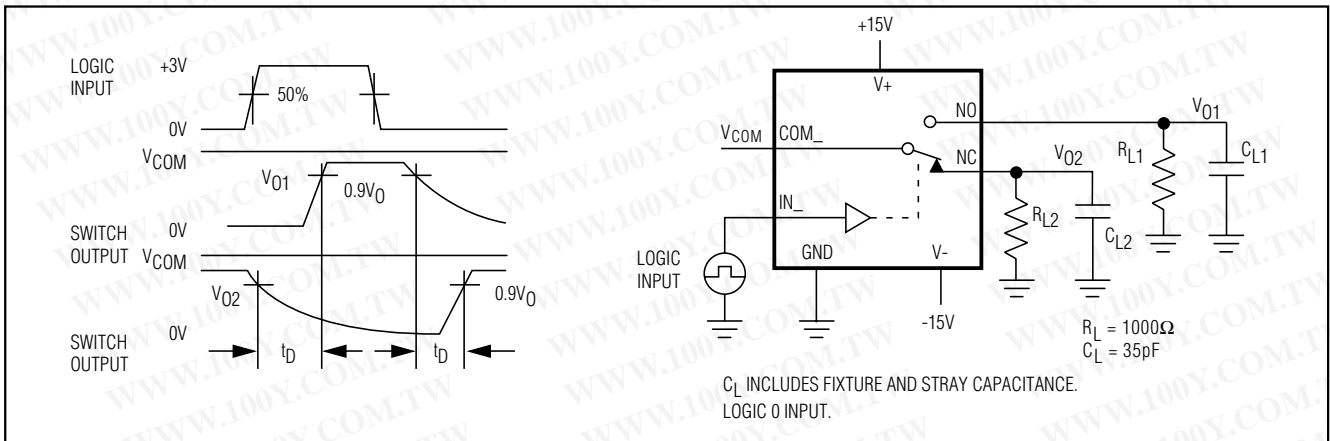

Figure 5. Break-Before-Make

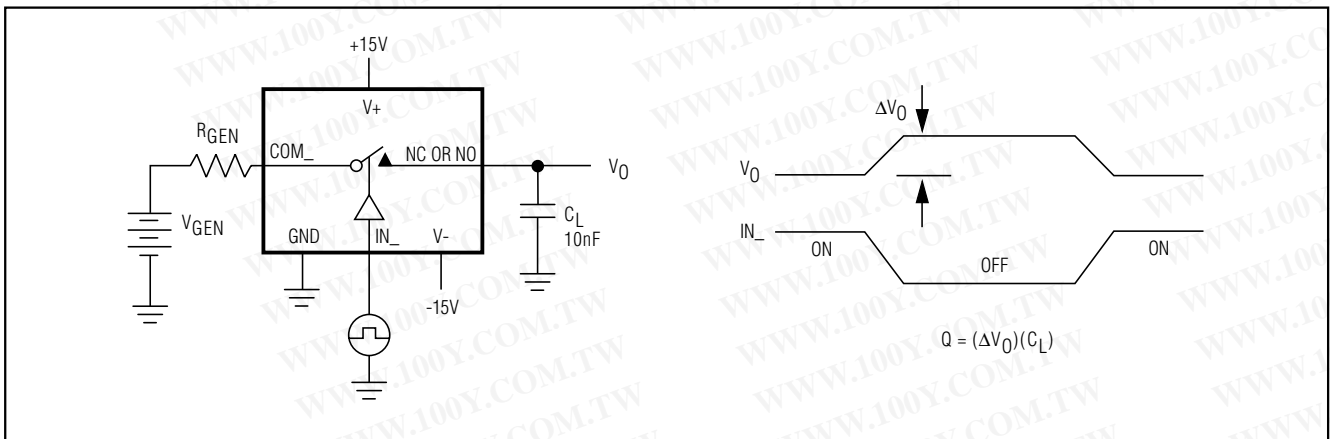

Figure 6. Charge Injection

Precision, Quad, SPDT, CMOS Analog Switch

Test Circuits/Timing Diagrams (continued)

MAX333A

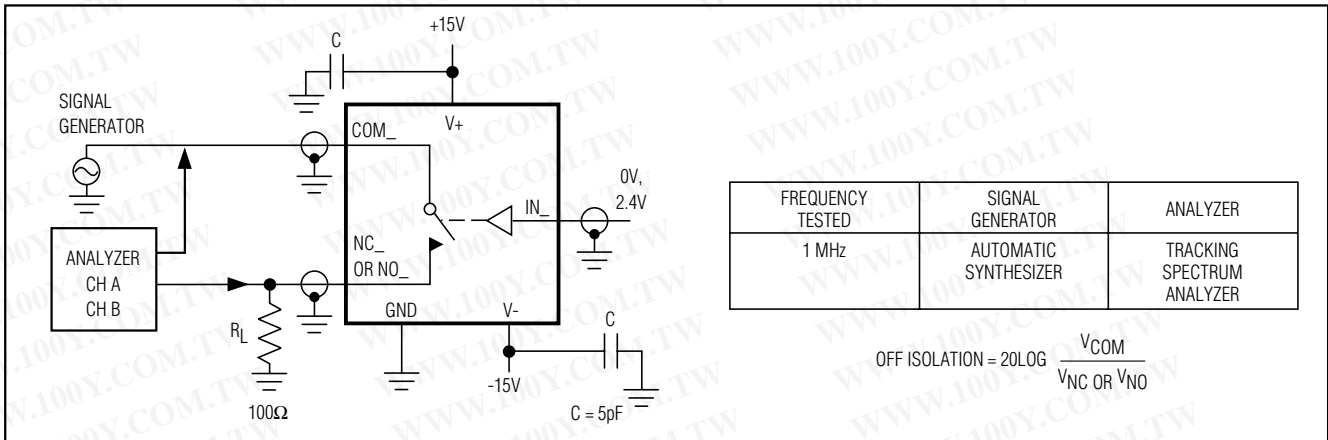

Figure 7. Off-Isolation

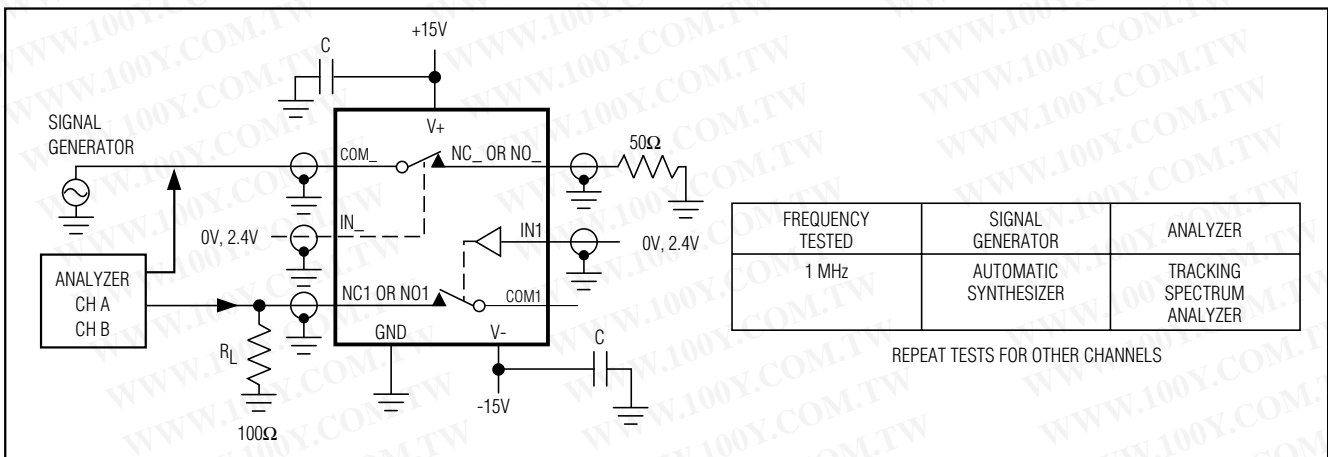
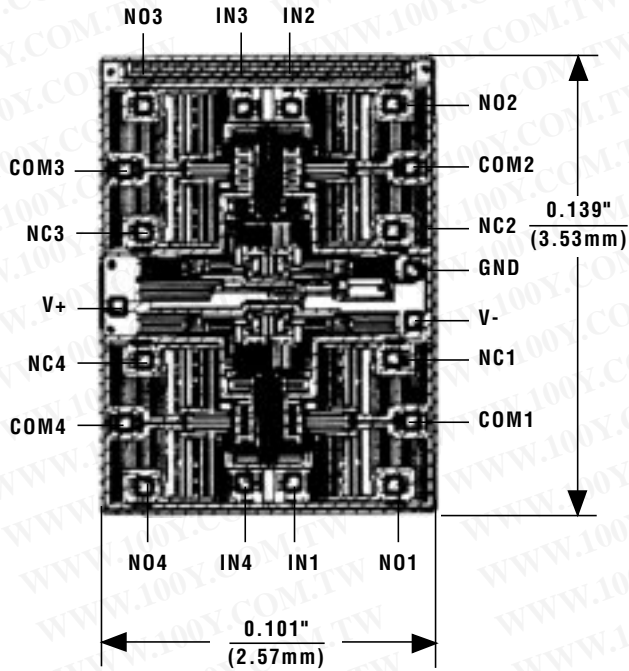

Figure 8. Crosstalk

Precision, Quad, SPDT, CMOS Analog Switch

MAX333A

Chip Topography



TRANSISTOR COUNT: 145;
 SUBSTRATE CONNECTED TO V+.

Maxim cannot assume responsibility for use of any circuitry other than circuitry entirely embodied in a Maxim product. No circuit patent licenses are implied. Maxim reserves the right to change the circuitry and specifications without notice at any time.

8 Maxim Integrated Products, 120 San Gabriel Drive, Sunnyvale, CA 94086 (408) 737-7600