

Single 16-Channel/Differential 8-Channel, CMOS Analog Multiplexers

The DG406 and DG407 monolithic CMOS analog multiplexers are drop-in replacements for the popular DG506A and DG507A series devices. They each include an array of sixteen analog switches, a TTL and CMOS compatible digital decode circuit for channel selection, a voltage reference for logic thresholds, and an ENABLE input for device selection when several multiplexers are present.

These multiplexers feature lower signal ON resistance (<100Ω) and faster transition time ($t_{TRANS} < 300ns$) compared to the DG506A and DG507A. Charge injection has been reduced, simplifying sample and hold applications.

The improvements in the DG406 series are made possible by using a high voltage silicon-gate process. An epitaxial layer prevents the latch-up associated with older CMOS technologies. The 44V maximum voltage range permits controlling 30V_{P-P} signals when operating with ±15V power supplies.

The sixteen switches are bilateral, equally matched for AC or bidirectional signals. The ON resistance variation with analog signals is quite low over a ±5V analog input range.

Pinouts

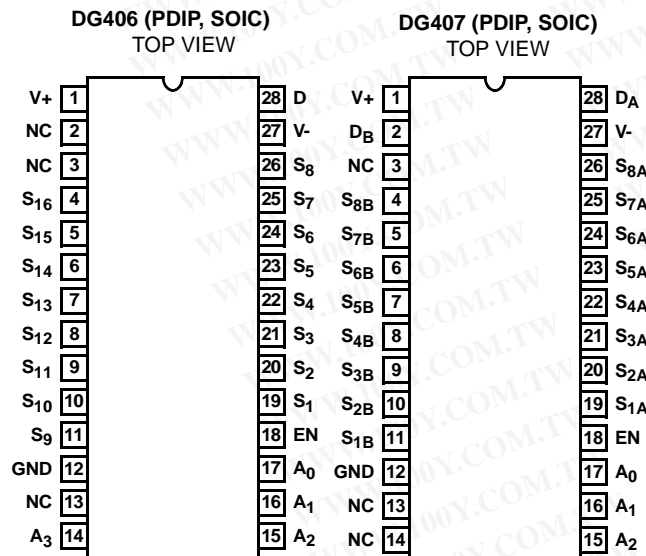

Features

- ON-Resistance (Max) 100Ω
- Low Power Consumption (P_D) <1.2mW
- Fast Transition Time (Max) 300ns
- Low Charge Injection
- TTL, CMOS Compatible
- Single or Split Supply Operation
- Pb-Free Plus Anneal Available (RoHS Compliant)

Applications

- Battery Operated Systems
- Data Acquisition
- Medical Instrumentation
- Hi-Rel Systems
- Communication Systems
- Automatic Test Equipment

Related Literature

- Technical Brief TB363 “Guidelines for Handling and Processing Moisture Sensitive Surface Mount Devices (SMDs)”

Ordering Information

PART NUMBER	PART MARKING	TEMP. RANGE (°C)	PACKAGE	PKG. DWG. #
DG406DJ	DG406DJ	-40 to 85	28 Ld PDIP	E28.6
DG406DJZ	DG406DJZ	-40 to 85	28 Ld PDIP* (Pb-free)	E28.6
DG406DY	DG406DY	-40 to 85	28 Ld SOIC	M28.3
DG406DY-T	DG406DY	28 Ld SOIC Tape and Reel		M28.3
DG406DYZ	DG406DYZ	-40 to 85	28 Ld SOIC (Pb-free)	M28.3
DG406DYZ-T	DG406DYZ	28 Ld SOIC Tape and Reel (Pb-free)		M28.3
DG407DJ	DG407DJ	-40 to 85	28 Ld PDIP	E28.6
DG407DJZ	DG407DJZ	-40 to 85	28 Ld PDIP* (Pb-free)	E28.6
DG407DY	DG407DY	-40 to 85	28 Ld SOIC	M28.3
DG407DYZ	DG407DYZ	-40 to 85	28 Ld SOIC (Pb-free)	M28.3

*Pb-free PDIPs can be used for through hole wave solder processing only. They are not intended for use in Reflow solder processing applications.

NOTE: Intersil Pb-free plus anneal products employ special Pb-free material sets; molding compounds/die attach materials and 100% matte tin plate termination finish, which are RoHS compliant and compatible with both SnPb and Pb-free soldering operations. Intersil Pb-free products are MSL classified at Pb-free peak reflow temperatures that meet or exceed the Pb-free requirements of IPC/JEDEC J STD-020.

勝特力材料 886-3-5753170
勝特力电子(上海) 86-21-34970699
勝特力电子(深圳) 86-755-83298787
[Http://www.100y.com.tw](http://www.100y.com.tw)

Schematic Diagram (Typical Channel)

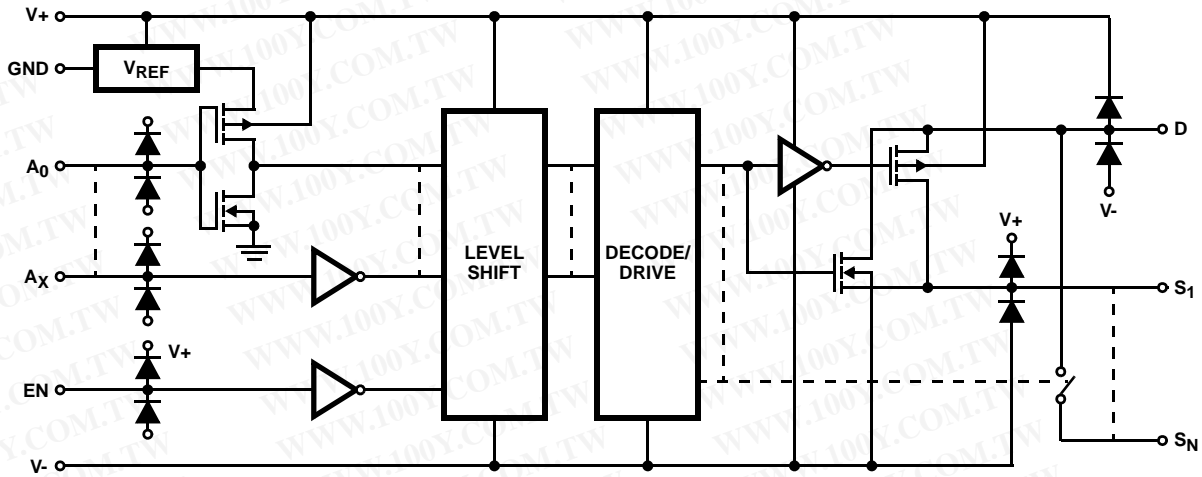

Functional Diagrams

DG406

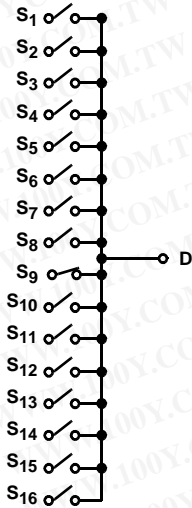

TO DECODER LOGIC
CONTROLLING BOTH
TIERS OF MUXING

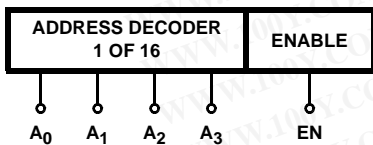

DG407

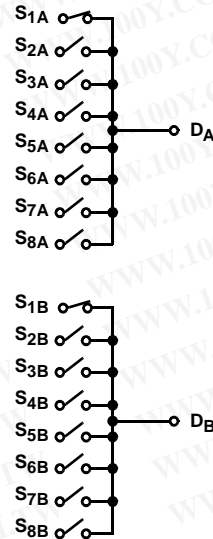

TO DECODER LOGIC
CONTROLLING BOTH
TIERS OF MUXING

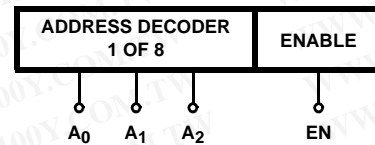

勝特力材料 886-3-5753170
 勝特力电子(上海) 86-21-34970699
 勝特力电子(深圳) 86-755-83298787
[Http://www.100y.com.tw](http://www.100y.com.tw)

DG406, DG407

DG406 TRUTH TABLE

A ₃	A ₂	A ₁	A ₀	EN	ON SWITCH
X	X	X	X	0	None
0	0	0	0	1	1
0	0	0	1	1	2
0	0	1	0	1	3
0	0	1	1	1	4
0	1	0	0	1	5
0	1	0	1	1	6
0	1	1	0	1	7
0	1	1	1	1	8
1	0	0	0	1	9
1	0	0	1	1	10
1	0	1	0	1	11
1	0	1	1	1	12
1	1	0	0	1	13
1	1	0	1	1	14
1	1	1	0	1	15
1	1	1	1	1	16

DG407 TRUTH TABLE

A ₂	A ₁	A ₀	EN	ON SWITCH PAIR
X	X	X	0	None
0	0	0	1	1
0	0	1	1	2
0	1	0	1	3
0	1	1	1	4
1	0	0	1	5
1	0	1	1	6
1	1	0	1	7
1	1	1	1	8

Logic "0" = V_{AL} < 0.8V.
 Logic "1" = V_{AH} > 2.4V.
 X = Don't Care.

勝特力材料 886-3-5753170
勝特力电子(上海) 86-21-34970699
勝特力电子(深圳) 86-755-83298787
[Http://www.100y.com.tw](http://www.100y.com.tw)

Absolute Maximum Ratings

V+ to V-	44.0V
GND to V-	25V
Digital Inputs, V _S , V _D (Note 1)	(V-) -2V to (V+) +2V or 20mA, Whichever Occurs First
Continuous Current (Any Terminal)	30mA
Peak Current, S or D (Pulsed 1ms, 10% Duty Cycle Max)	100mA

Operating Conditions

Temperature Range	-40°C to 85°C
-------------------	---------------

Thermal Information

Thermal Resistance (Typical, Note1)	θ_{JA} (°C/W)
PDIP Package*	60
SOIC Package	75
Maximum Junction Temperature	150°C
Maximum Storage Temperature Range	-65°C to 150°C
Maximum Lead Temperature (Soldering 10s)	300°C (PLCC and SOIC - Lead Tips Only)

*Pb-free PDIPs can be used for through hole wave solder processing only. They are not intended for use in Reflow solder processing applications.

CAUTION: Stresses above those listed in "Absolute Maximum Ratings" may cause permanent damage to the device. This is a stress only rating and operation of the device at these or any other conditions above those indicated in the operational sections of this specification is not implied.

NOTES:

1. θ_{JA} is measured with the component mounted on a low effective thermal conductivity test board in free air. See Tech Brief TB379 for details.
2. Signals on S_X, D_X, EN or A_X exceeding V+ or V- are clamped by internal diodes. Limit diode current to maximum current ratings.

Electrical Specifications

Test Conditions: V+ = +15V, V- = -15V, V_{AL} = 0.8V, V_{AH} = 2.4V Unless Otherwise Specified

PARAMETER	TEST CONDITIONS	TEMP (°C)	(NOTE 3) MIN	(NOTE 4) TYP	(NOTE 3) MAX	UNITS	
DYNAMIC CHARACTERISTICS							
Transition Time, t _{TRANS}	(See Figure 1)	25	-	200	300	ns	
		Full	-	-	400	ns	
Break-Before-Make Interval, t _{OPEN}	(See Figure 3)	25	25	50	-	ns	
		Full	10	-	-	ns	
Enable Turn-ON Time, t _{ON(EN)}	(See Figure 2)	25	-	150	200	ns	
		Full	-	-	400	ns	
Enable Turn-OFF Time, t _{OFF(EN)}		25	-	70	150	ns	
		Full	-	-	300	ns	
Charge Injection, Q	C _L = 1nF, V _S = 0V, R _S = 0Ω	25	-	40	-	pC	
OFF Isolation, OIRR	V _{EN} = 0V, R _L = 1kΩ, f = 100kHz (Note 7)	25	-	-69	-	dB	
Logic Input Capacitance, C _{IN}	f = 1MHz	25	-	7	-	pF	
Source OFF Capacitance, C _{S(OFF)}	V _{EN} = 0V, V _S = 0V, f = 1MHz	25	-	8	-	pF	
Drain OFF Capacitance, C _{D(OFF)}	V _{EN} = 0V, V _D = 0V, f = 1MHz	DG406	25	-	160	-	pF
		DG407	25	-	80	-	pF
Drain ON Capacitance, C _{D(ON)}	V _{EN} = 5V, V _D = 0V, f = 1MHz	DG406	25	-	180	-	pF
		DG407	25	-	90	-	pF
DIGITAL INPUT CHARACTERISTICS							
Logic High Input Voltage, V _{INH}		Full	2.4	-	-	V	
Logic Low Input Voltage, V _{INL}		Full	-	-	0.8	V	
Logic High Input Current, I _{AH}	V _A = 2.4V, 15V	Full	-1	-	1	μA	
Logic Low Input Current, I _{AL}	V _{EN} = 0V, 2.4V, V _A = 0V	Full	-1	-	1	μA	
ANALOG SWITCH CHARACTERISTICS							
Drain-Source ON Resistance, r _{DS(ON)}	V _D = ±10V, I _S = ±10mA (Note 5)	25	-	50	100	Ω	
		Full	-	-	125	Ω	
r _{DS(ON)} Matching Between Channels, Δr _{DS(ON)}	V _D = 10V, -10V (Note 6)	25	-	5	-	%	

DG406, DG407

Electrical Specifications Test Conditions: $V_+ = +15V$, $V_- = -15V$, $V_{AL} = 0.8V$, $V_{AH} = 2.4V$ Unless Otherwise Specified (Continued)

PARAMETER	TEST CONDITIONS	TEMP (°C)	(NOTE 3) MIN	(NOTE 4) TYP	(NOTE 3) MAX	UNITS	
Source OFF Leakage Current, $I_{S(OFF)}$	$V_{EN} = 0V$, $V_S = \pm 10V$, $V_D = \mp 10V$	25	-0.5	0.01	0.5	nA	
		Full	-5	-	5	nA	
Drain OFF Leakage Current, $I_{D(OFF)}$ DG406		25	-1	0.04	1	nA	
		Full	-40	-	40	nA	
		DG407	25	-1	0.04	1	nA
			Full	-20	-	20	nA
Drain ON Leakage Current, $I_{D(ON)}$ DG406	$V_S = V_D = \pm 10V$ (Note 5)	25	-1	0.04	1	nA	
		Full	-40	-	40	nA	
		DG407	25	-1	0.04	1	nA
			Full	-20	-	20	nA
POWER SUPPLY CHARACTERISTICS							
Positive Supply Current, I_+	$V_{EN} = V_A = 0V$ or $5V$ (Standby)	25	-	13	30	μA	
		Full	-	-	75	μA	
Negative Supply Current, I_-		25	-1	-0.01	-	μA	
		Full	-10	-	-	μA	
Positive Supply Current, I_+	$V_{EN} = 2.4V$, $V_A = 0V$ (Enabled)	25	-	80	100	μA	
		Full	-	-	200	μA	
Negative Supply Current, I_-		25	-1	-0.01	-	μA	
		Full	-10	-	-	μA	

Electrical Specifications Single Supply Test Conditions: $V_+ = 12V$, $V_- = 0V$, $V_{AL} = 0.8V$, $V_{AH} = 2.4V$, Unless Otherwise Specified

PARAMETER	TEST CONDITIONS	TEMP (°C)	(NOTE 3) MIN	(NOTE 4) TYP	(NOTE 3) MAX	UNITS
DYNAMIC CHARACTERISTICS						
Switching Time of Multiplexer, t_{TRANS}	$V_{S1} = 8V$, $V_{S8} = 0V$, $V_{IN} = 2.4V$	25	-	300	450	ns
Enable Turn-ON Time, $t_{ON(EN)}$	$V_{INH} = 2.4V$, $V_{INL} = 0V$, $V_{S1} = 5V$	25	-	250	600	ns
Enable Turn-OFF Time, $t_{OFF(EN)}$		25	-	150	300	ns
Charge Injection, Q	$C_L = 1nF$, $V_S = 6V$, $R_S = 0\Omega$	25	-	20	-	pC

勝特力材料 886-3-5753170
 勝特力电子(上海) 86-21-34970699
 勝特力电子(深圳) 86-755-83298787
[Http://www.100y.com.tw](http://www.100y.com.tw)

DG406, DG407

Electrical Specifications Single Supply Test Conditions: $V_+ = 12V$, $V_- = 0V$, $V_{AL} = 0.8V$, $V_{AH} = 2.4V$, Unless Otherwise Specified **(Continued)**

PARAMETER	TEST CONDITIONS	TEMP (°C)	(NOTE 3) MIN	(NOTE 4) TYP	(NOTE 3) MAX	UNITS
ANALOG SWITCH CHARACTERISTICS						
Analog Signal Range, V_{ANALOG}		Full	0	-	12	V
Drain-Source ON-Resistance, $r_{DS(ON)}$	$V_D = 3V, 10V, I_S = -1mA$ (Note 5)	25	-	90	120	Ω
$r_{DS(ON)}$ Matching Between Channels (Note 6), $\Delta r_{DS(ON)}$		25	-	5	-	%
Source Off Leakage Current, $I_{S(OFF)}$	$V_{EN} = 0V, V_D = 10V$ or $0.5V$, $V_S = 0.5V$ or $10V$	25	-	0.01	-	nA
Drain Off Leakage Current, $I_{D(OFF)}$						
DG406		25	-	0.04	-	nA
DG407	25	-	0.04	-	nA	
Drain On Leakage Current, $I_{D(ON)}$	$V_S = V_D = \pm 10V$ (Note 5)	25	-	0.04	-	nA
DG406		25	-	0.04	-	nA
DG407	25	-	0.04	-	nA	
POWER SUPPLY CHARACTERISTICS						
Positive Supply Current (I_+) (Standby)	$V_{EN} = 0V$ or $5V$, $V_A = 0V$ or $5V$	25	-	13	30	μA
		Full	-	13	75	μA
Negative Supply Current (I_-) (Enabled)		25	-1	-0.01	-	μA
		Full	-5	-0.01	-	μA

NOTES:

- The algebraic convention whereby the most negative value is a minimum and the most positive a maximum, is used in this data sheet.
- Typical values are for Design Aid Only, not guaranteed nor production tested.
- Sequence each switch ON.
- $\Delta r_{DS(ON)} = (r_{DS(ON)}(Max) - r_{DS(ON)}(Min)) \div r_{DS(ON)} \text{ average}$.
- Worst case isolation occurs on channel 8B due to proximity to the drain pin.

Test Circuits and Waveforms

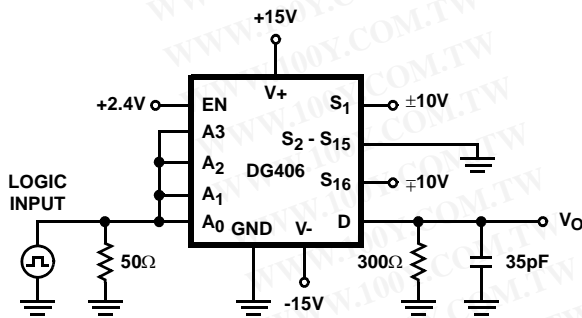

FIGURE 1A. DG406 TEST CIRCUIT

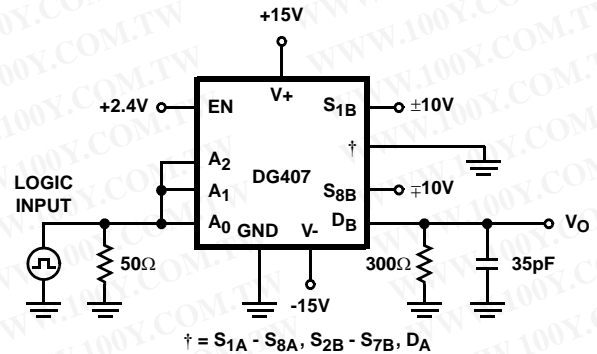

FIGURE 1B. DG407 TEST CIRCUIT

勝特力材料 886-3-5753170
 勝特力电子(上海) 86-21-34970699
 勝特力电子(深圳) 86-755-83298787
[Http://www.100y.com.tw](http://www.100y.com.tw)

Test Circuits and Waveforms (Continued)

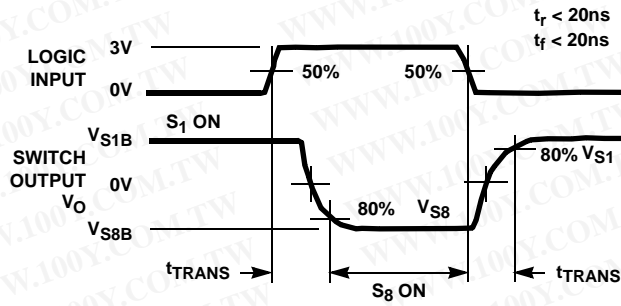

FIGURE 1C. MEASUREMENT POINTS

FIGURE 1. TRANSITION TIME

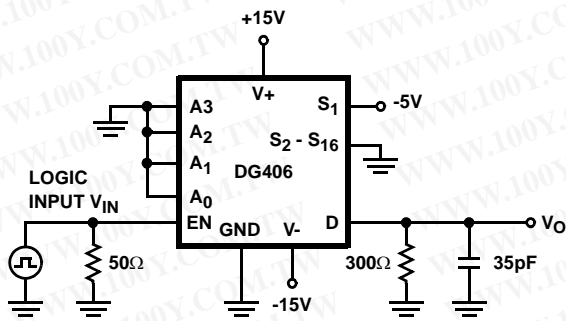

FIGURE 2A. DG406 TEST CIRCUIT

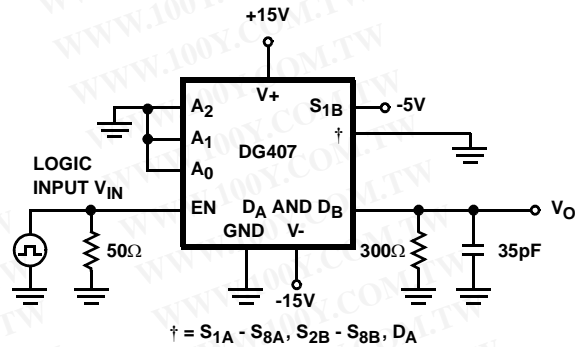

FIGURE 2B. DG407 TEST CIRCUIT

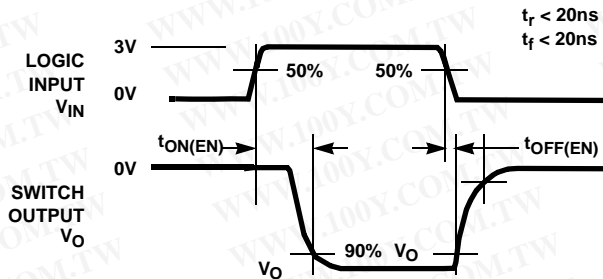

FIGURE 2C. MEASUREMENT POINTS

FIGURE 2. ENABLE SWITCHING TIMES

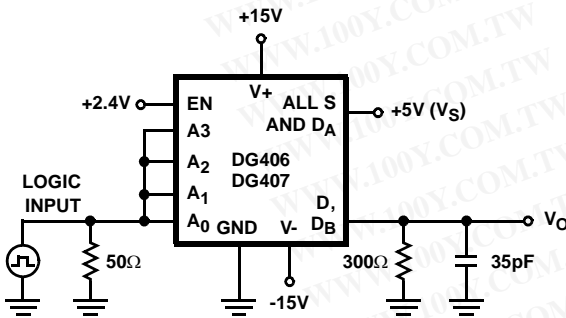

FIGURE 3A. TEST CIRCUIT

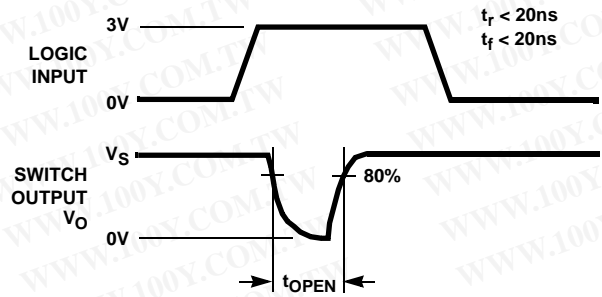

FIGURE 3B. MEASUREMENT POINTS

FIGURE 3. BREAK-BEFORE-MAKE INTERVAL

Typical Performance Curves

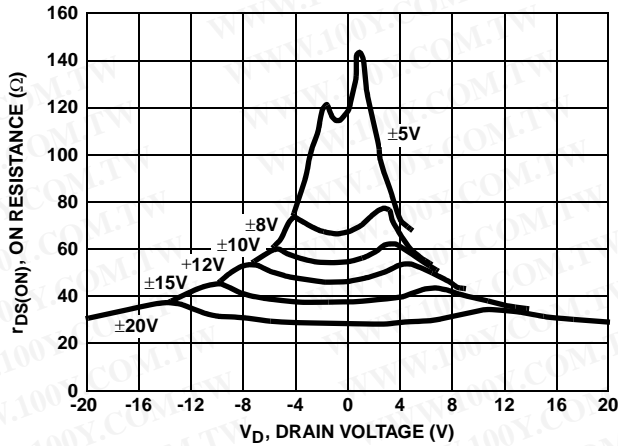

FIGURE 4. $r_{DS(ON)}$ vs V_D AND SUPPLY

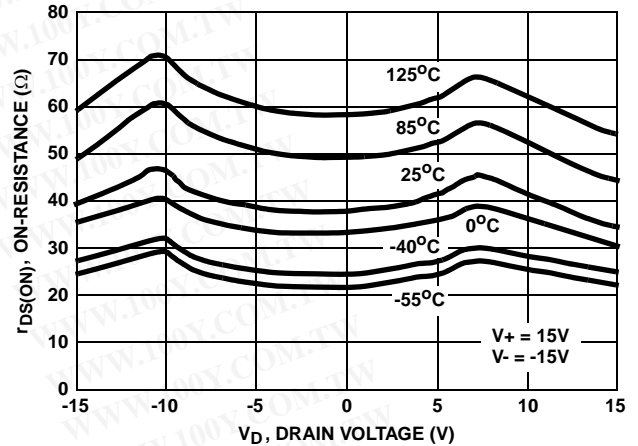

FIGURE 5. $r_{DS(ON)}$ vs V_D AND TEMPERATURE

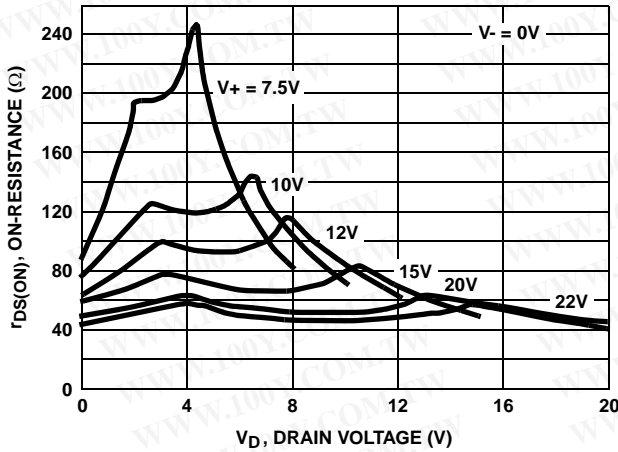

FIGURE 6. $r_{DS(ON)}$ vs V_D AND SUPPLY

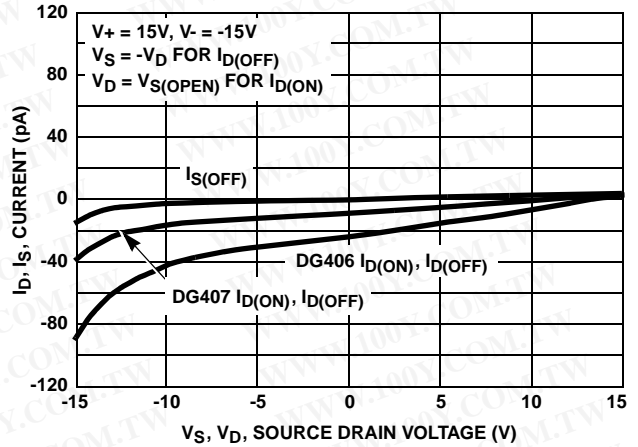

FIGURE 7. I_D, I_S LEAKAGE CURRENTS vs ANALOG VOLTAGE

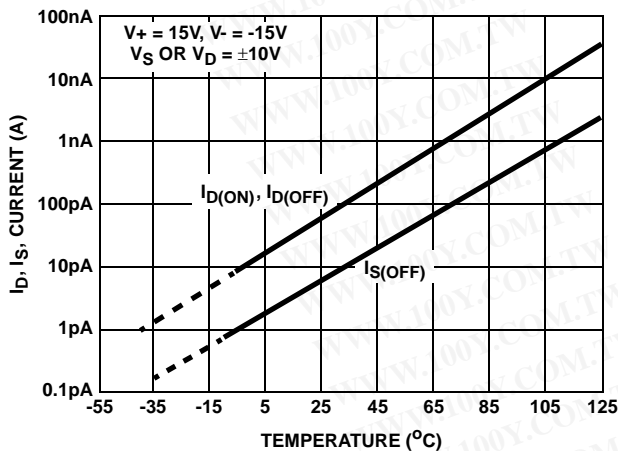

FIGURE 8. I_D, I_S LEAKAGE vs TEMPERATURE

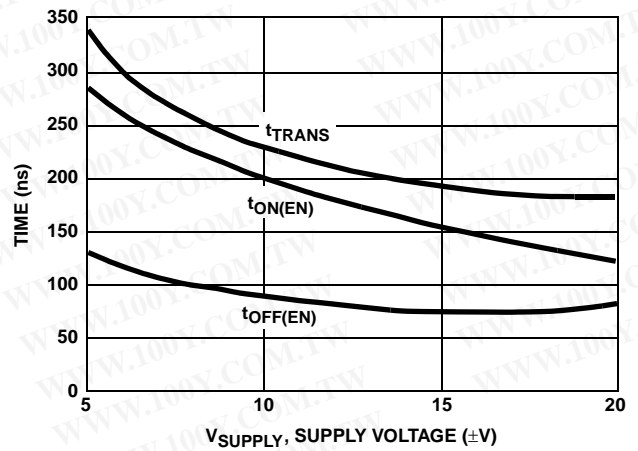

FIGURE 9. SWITCHING TIMES vs BIPOLAR SUPPLIES

Typical Performance Curves (Continued)

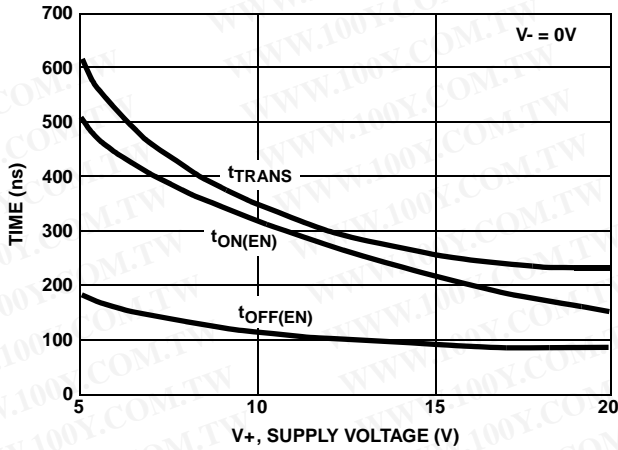

FIGURE 10. SWITCHING TIMES vs SINGLE SUPPLY

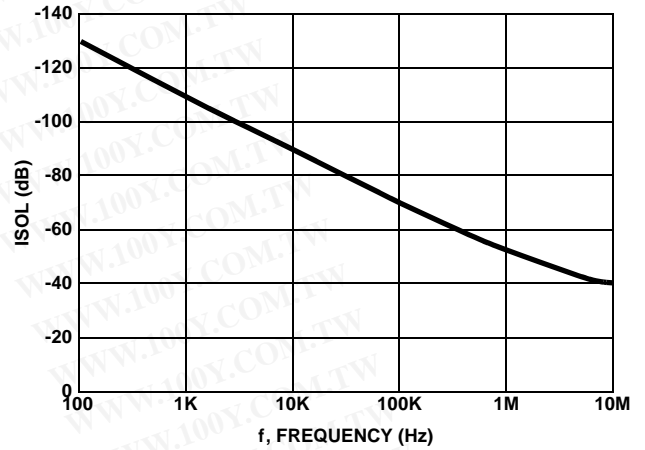

FIGURE 11. OFF ISOLATION vs FREQUENCY

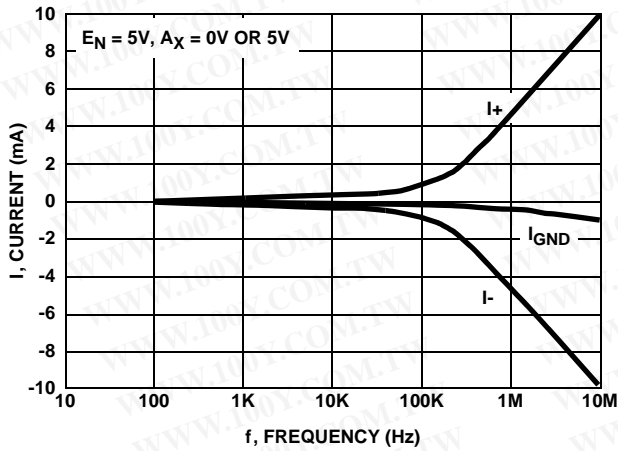

FIGURE 12. SUPPLY CURRENTS vs SWITCHING FREQUENCY

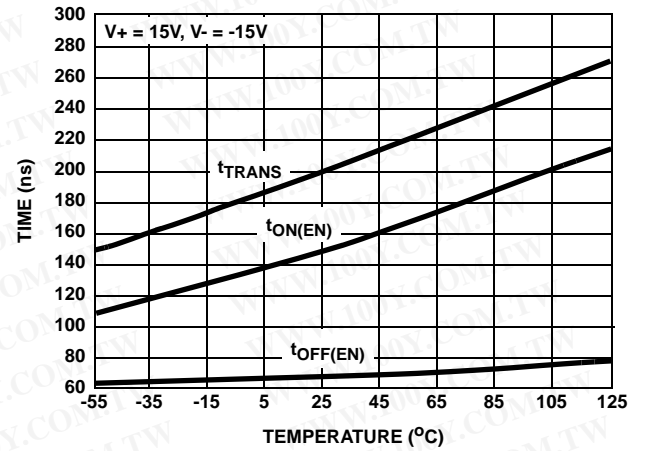

FIGURE 13. t_{ON}/t_{OFF} vs TEMPERATURE

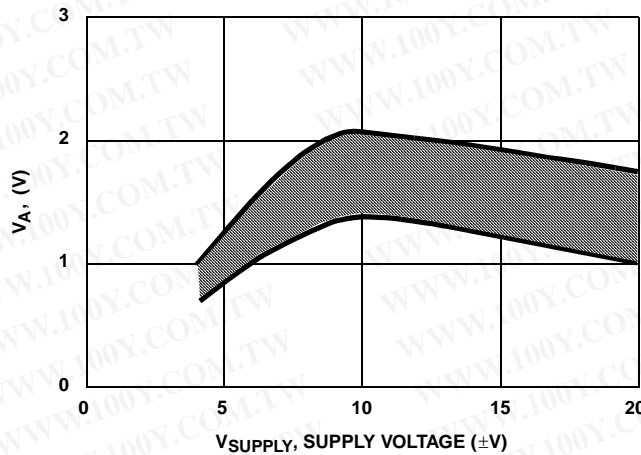

FIGURE 14. SWITCHING THRESHOLD vs SUPPLY VOLTAGE

DG406, DG407

Die Characteristics

DIE DIMENSIONS:

2490 μ m x 4560 μ m x 485 μ m

METALLIZATION:

Type: SiAl

Thickness: 12k \AA \pm 1k \AA

PASSIVATION:

Type: Nitride

Thickness: 8k \AA \pm 1k \AA

WORST CASE CURRENT DENSITY:

9.1 x 10⁴ A/cm²

Metallization Mask Layout

DG406

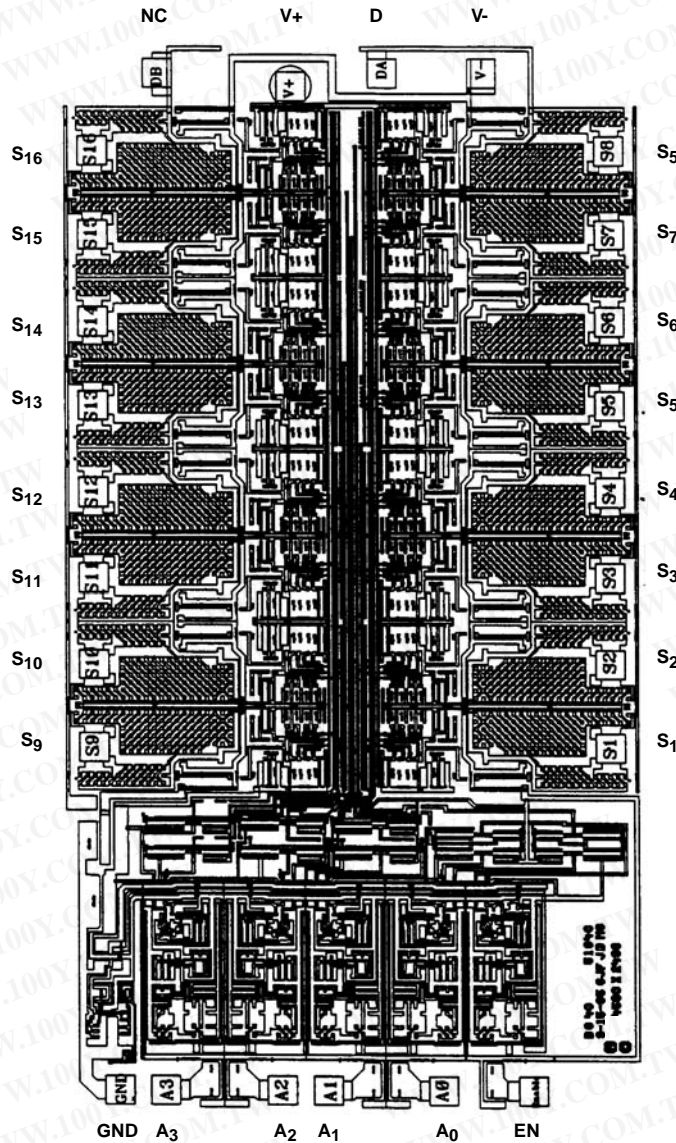

勝特力材料 886-3-5753170
勝特力电子(上海) 86-21-34970699
勝特力电子(深圳) 86-755-83298787
[Http://www.100y.com.tw](http://www.100y.com.tw)

DG406, DG407

Die Characteristics

DIE DIMENSIONS:

2490 μ m x 4560 μ m x 485 μ m

METALLIZATION:

Type: SiAl

Thickness: 12k \AA \pm 1k \AA

PASSIVATION:

Type: Nitride

Thickness: 8k \AA \pm 1k \AA

WORST CASE CURRENT DENSITY:

9.1 x 10⁴ A/cm²

Metallization Mask Layout

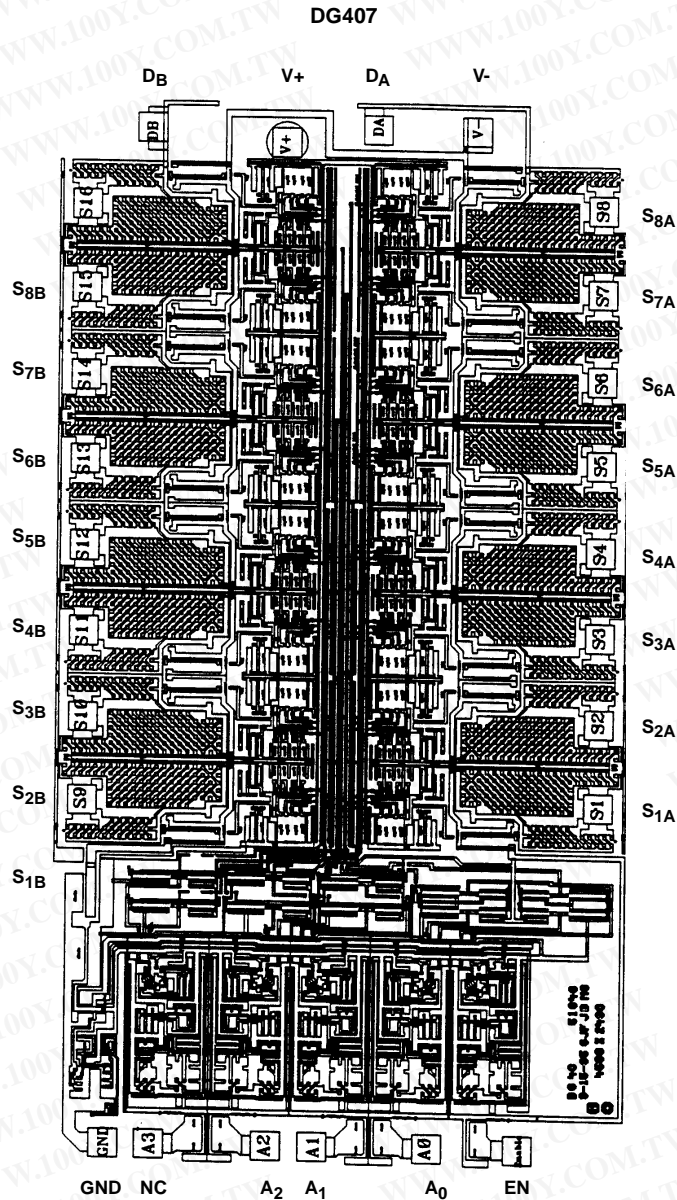

勝特力材料 886-3-5753170
勝特力电子(上海) 86-21-34970699
勝特力电子(深圳) 86-755-83298787
[Http://www.100y.com.tw](http://www.100y.com.tw)

Dual-In-Line Plastic Packages (PDIP)

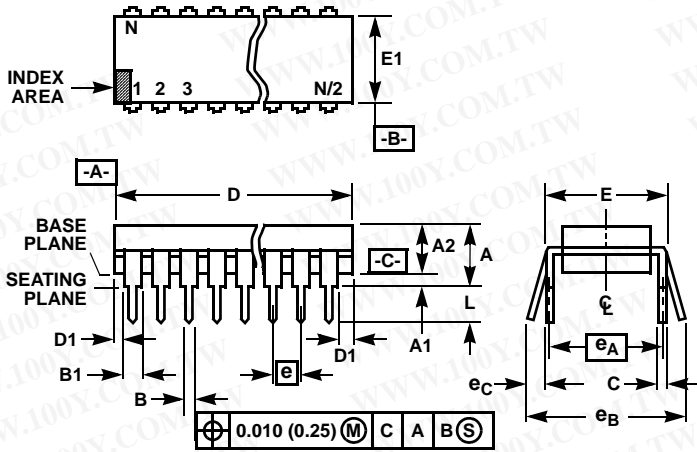

E28.6 (JEDEC MS-011-AB ISSUE B)
28 LEAD DUAL-IN-LINE PLASTIC PACKAGE

SYMBOL	INCHES		MILLIMETERS		NOTES
	MIN	MAX	MIN	MAX	
A	-	0.250	-	6.35	4
A1	0.015	-	0.39	-	4
A2	0.125	0.195	3.18	4.95	-
B	0.014	0.022	0.356	0.558	-
B1	0.030	0.070	0.77	1.77	8
C	0.008	0.015	0.204	0.381	-
D	1.380	1.565	35.1	39.7	5
D1	0.005	-	0.13	-	5
E	0.600	0.625	15.24	15.87	6
E1	0.485	0.580	12.32	14.73	5
e	0.100 BSC		2.54 BSC		-
e _A	0.600 BSC		15.24 BSC		6
e _B	-	0.700	-	17.78	7
L	0.115	0.200	2.93	5.08	4
N	28		28		9

NOTES:

- Controlling Dimensions: INCH. In case of conflict between English and Metric dimensions, the inch dimensions control.
- Dimensioning and tolerancing per ANSI Y14.5M-1982.
- Symbols are defined in the "MO Series Symbol List" in Section 2.2 of Publication No. 95.
- Dimensions A, A1 and L are measured with the package seated in JEDEC seating plane gauge GS-3.
- D, D1, and E1 dimensions do not include mold flash or protrusions. Mold flash or protrusions shall not exceed 0.010 inch (0.25mm).
- E and e_A are measured with the leads constrained to be perpendicular to datum -C-.
- e_B and e_C are measured at the lead tips with the leads unconstrained. e_C must be zero or greater.
- B1 maximum dimensions do not include dambar protrusions. Dambar protrusions shall not exceed 0.010 inch (0.25mm).
- N is the maximum number of terminal positions.
- Corner leads (1, N, N/2 and N/2 + 1) for E8.3, E16.3, E18.3, E28.3, E42.6 will have a B1 dimension of 0.030 - 0.045 inch (0.76 - 1.14mm).

Rev. 1 12/00

勝特力材料 886-3-5753170
 勝特力电子(上海) 86-21-34970699
 勝特力电子(深圳) 86-755-83298787
[Http://www.100y.com.tw](http://www.100y.com.tw)

Small Outline Plastic Packages (SOIC)

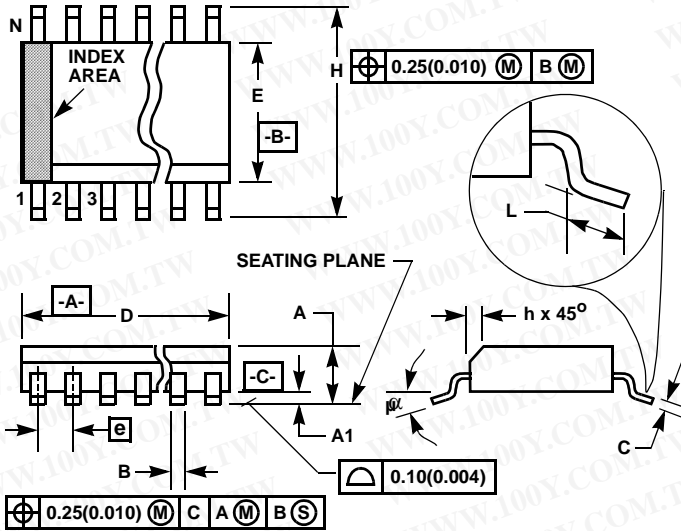

M28.3 (JEDEC MS-013-AE ISSUE C)
28 LEAD WIDE BODY SMALL OUTLINE PLASTIC PACKAGE

SYMBOL	INCHES		MILLIMETERS		NOTES
	MIN	MAX	MIN	MAX	
A	0.0926	0.1043	2.35	2.65	-
A1	0.0040	0.0118	0.10	0.30	-
B	0.013	0.0200	0.33	0.51	9
C	0.0091	0.0125	0.23	0.32	-
D	0.6969	0.7125	17.70	18.10	3
E	0.2914	0.2992	7.40	7.60	4
e	0.05 BSC		1.27 BSC		-
H	0.394	0.419	10.00	10.65	-
h	0.01	0.029	0.25	0.75	5
L	0.016	0.050	0.40	1.27	6
N	28		28		7
α	0°	8°	0°	8°	-

NOTES:

1. Symbols are defined in the "MO Series Symbol List" in Section 2.2 of Publication Number 95.
2. Dimensioning and tolerancing per ANSI Y14.5M-1982.
3. Dimension "D" does not include mold flash, protrusions or gate burrs. Mold flash, protrusion and gate burrs shall not exceed 0.15mm (0.006 inch) per side.
4. Dimension "E" does not include interlead flash or protrusions. Interlead flash and protrusions shall not exceed 0.25mm (0.010 inch) per side.
5. The chamfer on the body is optional. If it is not present, a visual index feature must be located within the crosshatched area.
6. "L" is the length of terminal for soldering to a substrate.
7. "N" is the number of terminal positions.
8. Terminal numbers are shown for reference only.
9. The lead width "B", as measured 0.36mm (0.014 inch) or greater above the seating plane, shall not exceed a maximum value of 0.61mm (0.024 inch)
10. Controlling dimension: MILLIMETER. Converted inch dimensions are not necessarily exact.

Rev. 0 12/93

勝特力材料 886-3-5753170
 勝特力电子(上海) 86-21-34970699
 勝特力电子(深圳) 86-755-83298787
[Http://www.100y.com.tw](http://www.100y.com.tw)

All Intersil U.S. products are manufactured, assembled and tested utilizing ISO9000 quality systems.
Intersil Corporation's quality certifications can be viewed at www.intersil.com/design/quality

Intersil products are sold by description only. Intersil Corporation reserves the right to make changes in circuit design, software and/or specifications at any time without notice. Accordingly, the reader is cautioned to verify that data sheets are current before placing orders. Information furnished by Intersil is believed to be accurate and reliable. However, no responsibility is assumed by Intersil or its subsidiaries for its use; nor for any infringements of patents or other rights of third parties which may result from its use. No license is granted by implication or otherwise under any patent or patent rights of Intersil or its subsidiaries.

For information regarding Intersil Corporation and its products, see www.intersil.com