



CMOS, 2.5 Ω Low Voltage, Triple/Quad SPDT Switches

勝特力材料 886-3-5753170
勝特力电子(上海) 86-21-34970699
勝特力电子(深圳) 86-755-83298787
[Http://www.100y.com.tw](http://www.100y.com.tw)

ADG733/ADG734

FEATURES

- 1.8 V to 5.5 V Single Supply
- ±2.5 V Dual Supply
- 2.5 Ω On Resistance
- 0.5 Ω On Resistance Flatness
- 100 pA Leakage Currents
- 19 ns Switching Times
- Triple SPDT: ADG733
- Quad SPDT: ADG734
- Small TSSOP and QSOP Packages
- Low Power Consumption
- TTL/CMOS Compatible Inputs

APPLICATIONS

- Data Acquisition Systems
- Communication Systems
- Relay Replacement
- Audio and Video Switching
- Battery Powered Systems

FUNCTIONAL BLOCK DIAGRAMS

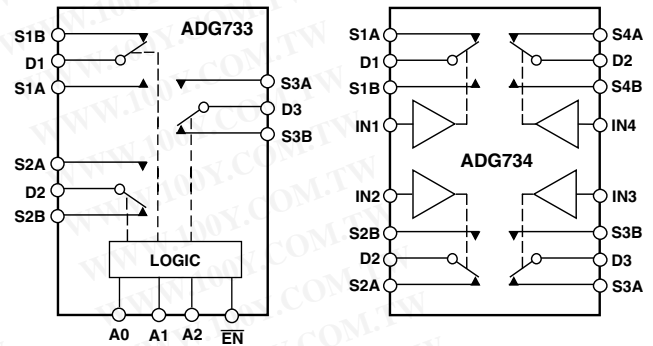

SWITCHES SHOWN FOR A "1" INPUT LOGIC

GENERAL DESCRIPTION

The ADG733 and ADG734 are low voltage, CMOS devices comprising three independently selectable SPDT (single pole, double throw) switches and four independently selectable SPDT switches respectively.

Low power consumption and operating supply range of 1.8 V to 5.5 V and dual ±2.5 V make the ADG733 and ADG734 ideal for battery powered, portable instruments. All channels exhibit break-before-make switching action preventing momentary shorting when switching channels. An \overline{EN} input on the ADG733 is used to enable or disable the device. When disabled, all channels are switched OFF.

These 2–1 multiplexers/SPDT switches are designed on an enhanced submicron process that provides low power dissipation yet gives high switching speed, very low on resistance, high signal bandwidths, and low leakage currents. On resistance is in the region of a few ohms, is closely matched between switches, and is very flat over the full signal range. These parts can operate equally well in either direction and have an input signal range that extends to the supplies.

The ADG733 is available in small TSSOP and QSOP packages, while the ADG734 is available in a small TSSOP package.

PRODUCT HIGHLIGHTS

1. Single/Dual Supply Operation. The ADG733 and ADG734 are fully specified and guaranteed with 3 V and 5 V single supply rails and ±2.5 V dual supply rails.
2. Low On Resistance (2.5 Ω typical)
3. Low Power Consumption (<0.01 μW)
4. Guaranteed Break-Before-Make Switching Action

REV. A

Information furnished by Analog Devices is believed to be accurate and reliable. However, no responsibility is assumed by Analog Devices for its use, nor for any infringements of patents or other rights of third parties that may result from its use. No license is granted by implication or otherwise under any patent or patent rights of Analog Devices.

One Technology Way, P.O. Box 9106, Norwood, MA 02062-9106, U.S.A.
Tel: 781/329-4700 www.analog.com
Fax: 781/326-8703 © Analog Devices, Inc., 2002

ADG733/ADG734—SPECIFICATIONS¹ ($V_{DD} = 5\text{ V} \pm 10\%$, $V_{SS} = 0\text{ V}$, $GND = 0\text{ V}$, unless otherwise noted.)

Parameter	B Version		Unit	Test Conditions/Comments
	+25°C	-40°C to +85°C		
ANALOG SWITCH				
Analog Signal Range		0 V to V_{DD}	V	
On Resistance (R_{ON})	2.5		Ω typ	$V_S = 0\text{ V}$ to V_{DD} , $I_{DS} = 10\text{ mA}$; Test Circuit 1
	4.5	5.0	Ω max	
On Resistance Match between Channels (ΔR_{ON})		0.1	Ω typ	$V_S = 0\text{ V}$ to V_{DD} , $I_{DS} = 10\text{ mA}$
		0.4	Ω max	
On Resistance Flatness ($R_{FLAT(ON)}$)	0.5		Ω typ	$V_S = 0\text{ V}$ to V_{DD} , $I_{DS} = 10\text{ mA}$
		1.2	Ω max	
LEAKAGE CURRENTS				
Source OFF Leakage I_S (OFF)	± 0.01		nA typ	$V_{DD} = 5.5\text{ V}$ $V_D = 4.5\text{ V}/1\text{ V}$, $V_S = 1\text{ V}/4.5\text{ V}$; Test Circuit 2
	± 0.1	± 0.3	nA max	
Channel ON Leakage I_D , I_S (ON)	± 0.01		nA typ	$V_D = V_S = 1\text{ V}$, or 4.5 V ; Test Circuit 3
	± 0.1	± 0.5	nA max	
DIGITAL INPUTS				
Input High Voltage, V_{INH}		2.4	V min	
Input Low Voltage, V_{INL}		0.8	V max	
Input Current I_{INL} or I_{INH}	0.005		μA typ	$V_{IN} = V_{INL}$ or V_{INH}
		± 0.1	μA max	
C_{IN} , Digital Input Capacitance	4		pF typ	
DYNAMIC CHARACTERISTICS²				
t_{ON}	19		ns typ	$R_L = 300\ \Omega$, $C_L = 35\text{ pF}$; $V_S = 3\text{ V}$, Test Circuit 4
		34	ns max	
t_{OFF}	7		ns typ	$R_L = 300\ \Omega$, $C_L = 35\text{ pF}$; $V_S = 3\text{ V}$, Test Circuit 4
		12	ns max	
ADG733 $t_{ON}(\overline{EN})$	20		ns typ	$R_L = 300\ \Omega$, $C_L = 35\text{ pF}$; $V_S = 3\text{ V}$, Test Circuit 5
		40	ns max	
$t_{OFF}(\overline{EN})$	7		ns typ	$R_L = 300\ \Omega$, $C_L = 35\text{ pF}$; $V_S = 3\text{ V}$, Test Circuit 5
		12	ns max	
Break-Before-Make Time Delay, t_D	13		ns typ	$R_L = 300\ \Omega$, $C_L = 35\text{ pF}$; $V_S = 3\text{ V}$, Test Circuit 6
		1	ns min	
Charge Injection	± 3		pC typ	$V_S = 2\text{ V}$, $R_S = 0\ \Omega$, $C_L = 1\text{ nF}$; Test Circuit 7
Off Isolation	-72		dB typ	$R_L = 50\ \Omega$, $C_L = 5\text{ pF}$, $f = 1\text{ MHz}$; Test Circuit 8
Channel-to-Channel Crosstalk	-67		dB typ	$R_L = 50\ \Omega$, $C_L = 5\text{ pF}$, $f = 1\text{ MHz}$; Test Circuit 9
-3 dB Bandwidth	160		MHz typ	$R_L = 50\ \Omega$, $C_L = 5\text{ pF}$, Test Circuit 10
C_S (OFF)	11		pF typ	$f = 1\text{ MHz}$
C_D , C_S (ON)	34		pF typ	$f = 1\text{ MHz}$
POWER REQUIREMENTS				
I_{DD}	0.001		μA typ	$V_{DD} = 5.5\text{ V}$ Digital Inputs = 0 V or 5.5 V
		1.0	μA max	

NOTES

¹Temperature range is as follows: B Version: -40°C to +85°C.

²Guaranteed by design, not subject to production test.

Specifications subject to change without notice.

勝特力材料 886-3-5753170
勝特力电子(上海) 86-21-34970699
勝特力电子(深圳) 86-755-83298787
[Http://www.100y.com.tw](http://www.100y.com.tw)

SPECIFICATIONS¹

($V_{DD} = 3\text{ V} \pm 10\%$, $V_{SS} = 0\text{ V}$, $GND = 0\text{ V}$, unless otherwise noted.)

ADG733/ADG734

Parameter	B Version		Unit	Test Conditions/Comments
	+25°C	-40°C to +85°C		
ANALOG SWITCH				
Analog Signal Range		0 V to V_{DD}	V	
On Resistance (R_{ON})	6		Ω typ	$V_S = 0\text{ V}$ to V_{DD} , $I_{DS} = 10\text{ mA}$; Test Circuit 1
	11	12	Ω max	
On Resistance Match between Channels (ΔR_{ON})		0.1	Ω typ	$V_S = 0\text{ V}$ to V_{DD} , $I_{DS} = 10\text{ mA}$
		0.4	Ω max	
On Resistance Flatness ($R_{FLAT(ON)}$)		3	Ω typ	$V_S = 0\text{ V}$ to V_{DD} , $I_{DS} = 10\text{ mA}$
LEAKAGE CURRENTS				
Source OFF Leakage I_S (OFF)	± 0.01		nA typ	$V_{DD} = 3.3\text{ V}$ $V_S = 3\text{ V}/1\text{ V}$, $V_D = 1\text{ V}/3\text{ V}$; Test Circuit 2
	± 0.1	± 0.3	nA max	
Channel ON Leakage I_D , I_S (ON)	± 0.01		nA typ	$V_S = V_D = 1\text{ V}$ or 3 V ; Test Circuit 3
	± 0.1	± 0.5	nA max	
DIGITAL INPUTS				
Input High Voltage, V_{INH}		2.0	V min	
Input Low Voltage, V_{INL}		0.8	V max	
Input Current I_{INL} or I_{INH}	0.005		μA typ	$V_{IN} = V_{INL}$ or V_{INH}
		± 0.1	μA max	
C_{IN} , Digital Input Capacitance	4		pF typ	
DYNAMIC CHARACTERISTICS²				
t_{ON}	28		ns typ	$R_L = 300\ \Omega$, $C_L = 35\text{ pF}$; $V_S = 2\text{ V}$, Test Circuit 4
		55	ns max	$R_L = 300\ \Omega$, $C_L = 35\text{ pF}$; $V_S = 2\text{ V}$, Test Circuit 4
t_{OFF}	9		ns typ	$R_L = 300\ \Omega$, $C_L = 35\text{ pF}$; $V_S = 2\text{ V}$, Test Circuit 4
		16	ns max	$R_L = 300\ \Omega$, $C_L = 35\text{ pF}$; $V_S = 2\text{ V}$, Test Circuit 5
ADG733 $t_{ON}(\overline{EN})$	29		ns typ	$R_L = 300\ \Omega$, $C_L = 35\text{ pF}$; $V_S = 2\text{ V}$, Test Circuit 5
		60	ns max	$R_L = 300\ \Omega$, $C_L = 35\text{ pF}$; $V_S = 2\text{ V}$, Test Circuit 5
$t_{OFF}(\overline{EN})$	9		ns typ	$R_L = 300\ \Omega$, $C_L = 35\text{ pF}$; $V_S = 2\text{ V}$, Test Circuit 5
		16	ns max	$R_L = 300\ \Omega$, $C_L = 35\text{ pF}$; $V_S = 2\text{ V}$, Test Circuit 6
Break-Before-Make Time Delay, t_D	22		ns typ	$R_L = 300\ \Omega$, $C_L = 35\text{ pF}$; $V_S = 2\text{ V}$, Test Circuit 6
		1	ns min	$V_S = 1\text{ V}$, $R_S = 0\ \Omega$, $C_L = 1\text{ nF}$; Test Circuit 7
Charge Injection	± 3		pC typ	$R_L = 50\ \Omega$, $C_L = 5\text{ pF}$, $f = 1\text{ MHz}$; Test Circuit 8
Off Isolation	-72		dB typ	$R_L = 50\ \Omega$, $C_L = 5\text{ pF}$, $f = 1\text{ MHz}$; Test Circuit 9
Channel-to-Channel Crosstalk	-67		dB typ	$R_L = 50\ \Omega$, $C_L = 5\text{ pF}$, $f = 1\text{ MHz}$; Test Circuit 10
-3 dB Bandwidth	160		MHz typ	$R_L = 50\ \Omega$, $C_L = 5\text{ pF}$, $f = 1\text{ MHz}$
C_S (OFF)	11		pF typ	$f = 1\text{ MHz}$
C_D , C_S (ON)	34		pF typ	$f = 1\text{ MHz}$
POWER REQUIREMENTS				
I_{DD}	0.001		μA typ	$V_{DD} = 3.3\text{ V}$ Digital Inputs = 0 V or 3.3 V
		1.0	μA max	

NOTES

¹Temperature ranges are as follows: B Version: -40°C to +85°C.

²Guaranteed by design, not subject to production test.

Specifications subject to change without notice.

勝特力材料 886-3-5753170
勝特力电子(上海) 86-21-34970699
勝特力电子(深圳) 86-755-83298787
[Http://www.100y.com.tw](http://www.100y.com.tw)

ADG733/ADG734—SPECIFICATIONS¹

DUAL SUPPLY ($V_{DD} = +2.5\text{ V} \pm 10\%$, $V_{SS} = -2.5\text{ V} \pm 10\%$, $GND = 0\text{ V}$, unless otherwise noted.)

Parameter	B Version		Unit	Test Conditions/Comments
	+25°C	-40°C to +85°C		
ANALOG SWITCH				
Analog Signal Range		V_{SS} to V_{DD}	V	
On Resistance (R_{ON})	2.5		Ω typ	$V_S = V_{SS}$ to V_{DD} , $I_{DS} = 10\text{ mA}$;
	4.5	5.0	Ω max	Test Circuit 1
On Resistance Match between Channels (ΔR_{ON})		0.1	Ω typ	$V_S = V_{SS}$ to V_{DD} , $I_{DS} = 10\text{ mA}$
		0.4	Ω max	
On Resistance Flatness ($R_{FLAT(ON)}$)	0.5		Ω typ	$V_S = V_{SS}$ to V_{DD} , $I_{DS} = 10\text{ mA}$
		1.2	Ω max	
LEAKAGE CURRENTS				
Source OFF Leakage I_S (OFF)	± 0.01		nA typ	$V_{DD} = +2.75\text{ V}$, $V_{SS} = -2.75\text{ V}$
	± 0.1	± 0.3	nA max	$V_S = +2.25\text{ V}/-1.25\text{ V}$, $V_D = -1.25\text{ V}/+2.25\text{ V}$;
Channel ON Leakage I_D , I_S (ON)	± 0.01		nA typ	Test Circuit 2
	± 0.1	± 0.5	nA max	$V_S = V_D = +2.25\text{ V}/-1.25\text{ V}$, Test Circuit 3
DIGITAL INPUTS				
Input High Voltage, V_{INH}		1.7	V min	
Input Low Voltage, V_{INL}		0.7	V max	
Input Current				
I_{INL} or I_{INH}	0.005		μA typ	$V_{IN} = V_{INL}$ or V_{INH}
		± 0.1	μA max	
C_{IN} , Digital Input Capacitance	4		pF typ	
DYNAMIC CHARACTERISTICS²				
t_{ON}	21		ns typ	$R_L = 300\ \Omega$, $C_L = 35\text{ pF}$;
		35	ns max	$V_S = 1.5\text{ V}$, Test Circuit 4
t_{OFF}	10		ns typ	$R_L = 300\ \Omega$, $C_L = 35\text{ pF}$;
		16	ns max	$V_S = 1.5\text{ V}$, Test Circuit 4
ADG733 $t_{ON}(\overline{EN})$	21		ns typ	$R_L = 300\ \Omega$, $C_L = 35\text{ pF}$;
		40	ns max	$V_S = 1.5\text{ V}$, Test Circuit 5
$t_{OFF}(\overline{EN})$	10		ns typ	$R_L = 300\ \Omega$, $C_L = 35\text{ pF}$;
		16	ns max	$V_S = 1.5\text{ V}$, Test Circuit 5
Break-Before-Make Time Delay, t_D	13		ns typ	$R_L = 300\ \Omega$, $C_L = 35\text{ pF}$;
		1	ns min	$V_S = 1.5\text{ V}$, Test Circuit 6
Charge Injection	± 5		pC typ	$V_S = 0\text{ V}$, $R_S = 0\ \Omega$, $C_L = 1\text{ nF}$;
				Test Circuit 7
Off Isolation	-72		dB typ	$R_L = 50\ \Omega$, $C_L = 5\text{ pF}$, $f = 1\text{ MHz}$;
				Test Circuit 8
Channel-to-Channel Crosstalk	-67		dB typ	$R_L = 50\ \Omega$, $C_L = 5\text{ pF}$, $f = 1\text{ MHz}$;
				Test Circuit 9
-3 dB Bandwidth	200		MHz typ	$R_L = 50\ \Omega$, $C_L = 5\text{ pF}$, Test Circuit 10
C_S (OFF)	11		pF typ	$f = 1\text{ MHz}$
C_D , C_S (ON)	34		pF typ	$f = 1\text{ MHz}$
POWER REQUIREMENTS				
I_{DD}	0.001		μA typ	$V_{DD} = 2.75\text{ V}$
		1.0	μA max	Digital Inputs = 0 V or 2.75 V
I_{SS}	0.001		μA typ	$V_{SS} = -2.75\text{ V}$
		1.0	μA max	Digital Inputs = 0 V or 2.75 V

NOTES

¹Temperature range is as follows: B Version: -40°C to +85°C.

²Guaranteed by design, not subject to production test.

Specifications subject to change without notice.

勝特力材料 886-3-5753170
勝特力电子(上海) 86-21-34970699
勝特力电子(深圳) 86-755-83298787
[Http://www.100y.com.tw](http://www.100y.com.tw)

ABSOLUTE MAXIMUM RATINGS¹

(T_A = 25°C, unless otherwise noted.)

V _{DD} to V _{SS}	7 V
V _{DD} to GND	-0.3 V to +7 V
V _{SS} to GND	+0.3 V to -3.5 V
Analog Inputs ²	V _{SS} - 0.3 V to V _{DD} + 0.3 V or 30 mA, Whichever Occurs First
Digital Inputs ²	-0.3 V to V _{DD} + 0.3 V or 30 mA, Whichever Occurs First
Peak Current, S or D	100 mA (Pulsed at 1 ms, 10% Duty Cycle max)
Continuous Current, S or D	30 mA
Operating Temperature Range	
Industrial (A, B Versions)	-40°C to +85°C
Storage Temperature Range	-65°C to +150°C

Junction Temperature	150°C
16-Lead TSSOP, θ _{JA} Thermal Impedance	150.4°C/W
20-Lead TSSOP, θ _{JA} Thermal Impedance	143°C/W
16-Lead QSOP, θ _{JA} Thermal Impedance	149.97°C/W
Lead Temperature, Soldering (10 sec)	300°C
IR Reflow, Peak Temperature (<20 sec)	235°C

NOTES

¹ Stresses above those listed under Absolute Maximum Ratings may cause permanent damage to the device. This is a stress rating only; functional operation of the device at these or any other conditions above those listed in the operational sections of this specification is not implied. Exposure to absolute maximum rating conditions for extended periods may affect device reliability. Only one absolute maximum rating may be applied at any one time.

² Overvoltages at A, EN, IN, S, or D will be clamped by internal diodes. Current should be limited to the maximum ratings given.

ORDERING GUIDE

Model	Temperature Range	Package Description	Package Option
ADG733BRU	-40°C to +85°C	Thin Shrink Small Outline Package (TSSOP)	RU-16
ADG733BRQ	-40°C to +85°C	Quarter Size Outline Package (QSOP)	RQ-16
ADG734BRU	-40°C to +85°C	Thin Shrink Small Outline Package (TSSOP)	RU-20

CAUTION

ESD (electrostatic discharge) sensitive device. Electrostatic charges as high as 4000 V readily accumulate on the human body and test equipment and can discharge without detection. Although the ADG733/ADG734 feature proprietary ESD protection circuitry, permanent damage may occur on devices subjected to high energy electrostatic discharges. Therefore, proper ESD precautions are recommended to avoid performance degradation or loss of functionality.



PIN CONFIGURATIONS

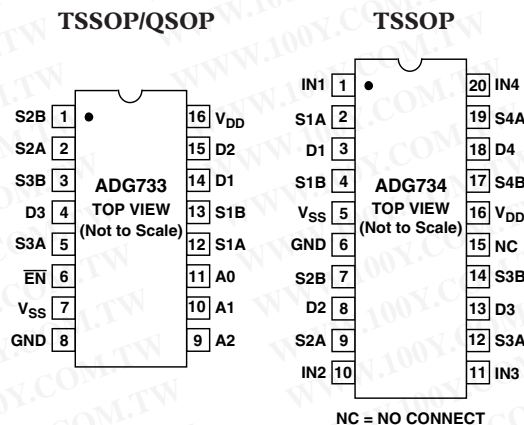

勝特力材料 886-3-5753170
 勝特力电子(上海) 86-21-34970699
 勝特力电子(深圳) 86-755-83298787
[Http://www.100y.com.tw](http://www.100y.com.tw)

ADG733/ADG734

Table I. ADG733 Truth Table

A2	A1	A0	$\overline{\text{EN}}$	ON Switch
X	X	X	1	None
0	0	0	0	D1-S1A, D2-S2A, D3-S3A
0	0	1	0	D1-S1B, D2-S2A, D3-S3A
0	1	0	0	D1-S1A, D2-S2B, D3-S3A
0	1	1	0	D1-S1B, D2-S2B, D3-S3A
1	0	0	0	D1-S1A, D2-S2A, D3-S3B
1	0	1	0	D1-S1B, D2-S2A, D3-S3B
1	1	0	0	D1-S1A, D2-S2B, D3-S3B
1	1	1	0	D1-S1B, D2-S2B, D3-S3B

X = Don't Care.

Table II. ADG734 Truth Table

Logic	Switch A	Switch B
0	OFF	ON
1	ON	OFF

勝特力材料 886-3-5753170
 勝特力电子(上海) 86-21-34970699
 勝特力电子(深圳) 86-755-83298787
[Http://www.100y.com.tw](http://www.100y.com.tw)

TERMINOLOGY

V_{DD}	Most Positive Power Supply Potential
V_{SS}	Most Negative Power Supply in a Dual Supply Application. In single supply applications, this should be tied to ground close to the device.
I_{DD}	Positive Supply Current
I_{SS}	Negative Supply Current
GND	Ground (0 V) Reference
S	Source Terminal. May be an input or output.
D	Drain Terminal. May be an input or output.
A_X	Logic Control Input
$\overline{\text{EN}}$	Active low device enable
$V_D (V_S)$	Analog Voltage on Terminals D and S
R_{ON}	Ohmic Resistance between D and S
ΔR_{ON}	On Resistance Match between any Two Channels (i.e., $R_{ON,max}$ and $R_{ON,min}$)
$R_{FLAT(ON)}$	Flatness is defined as the difference between the maximum and minimum value of on resistance as measured over the specified analog signal range.
I_S (OFF)	Source Leakage Current with the Switch "OFF"
I_D, I_S (ON)	Channel Leakage Current with the Switch "ON"
V_{INL}	Maximum Input Voltage for Logic "0"
V_{INH}	Minimum Input Voltage for Logic "1"
$I_{INL}(I_{INH})$	Input Current of the Digital Input
C_S (OFF)	"OFF" Switch Source Capacitance. Measured with reference to ground.
$C_D, C_S(ON)$	"ON" Switch Capacitance. Measured with reference to ground.
C_{IN}	Digital Input Capacitance
t_{ON}	Delay Time Measured between the 50% and 90% Points of the Digital Inputs and the Switch "ON" Condition
t_{OFF}	Delay Time Measured between the 50% and 90% Points of the Digital Input and the Switch "OFF" Condition
$t_{ON}(\overline{\text{EN}})$	Delay Time between the 50% and 90% Points of the $\overline{\text{EN}}$ Digital Input and the Switch "ON" Condition
$t_{OFF}(\overline{\text{EN}})$	Delay Time between the 50% and 90% Points of the $\overline{\text{EN}}$ Digital Input and the Switch "OFF" Condition
t_{OPEN}	"OFF" Time Measured between the 80% Points of Both Switches when Switching from One Address State to Another
Charge	A Measure of the Glitch Impulse Transferred Injection from the Digital Input to the Analog Output during Switching
Off Isolation	A Measure of Unwanted Signal Coupling through an "OFF" Switch.
Crosstalk	A Measure of Unwanted Signal that Is Coupled through from One Channel to Another as a Result of Parasitic Capacitance
On Response	The Frequency Response of the "ON" Switch
Insertion Loss	The Loss Due to the On Resistance of the switch

Typical Performance Characteristics—ADG733/ADG734

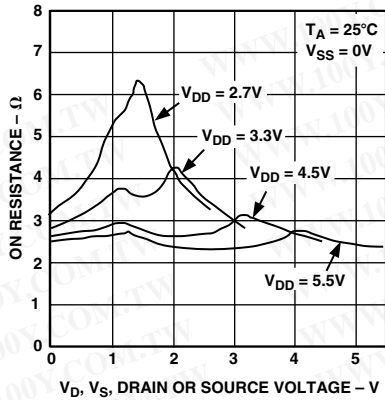

TPC 1. On Resistance as a Function of V_D (V_S) for Single Supply

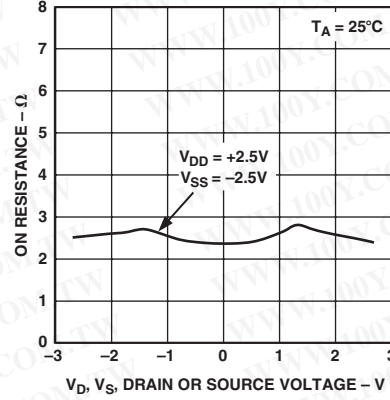

TPC 2. On Resistance as a Function of V_D (V_S) for Dual Supply

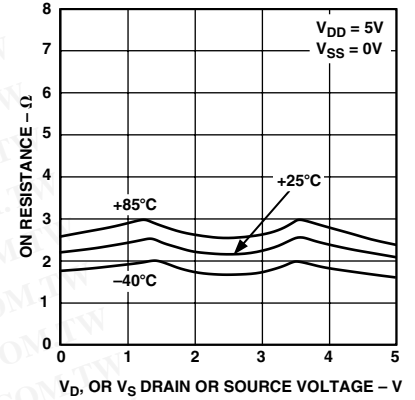

TPC 3. On Resistance as a Function of V_D (V_S) for Different Temperatures, Single Supply

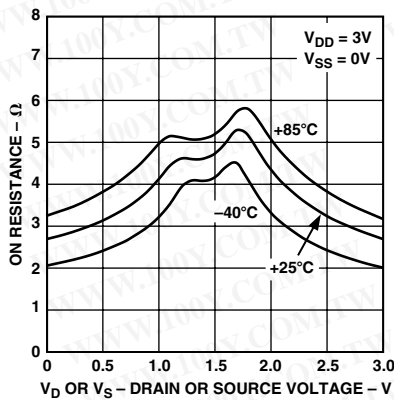

TPC 4. On Resistance as a Function of V_D (V_S) for Different Temperatures, Single Supply

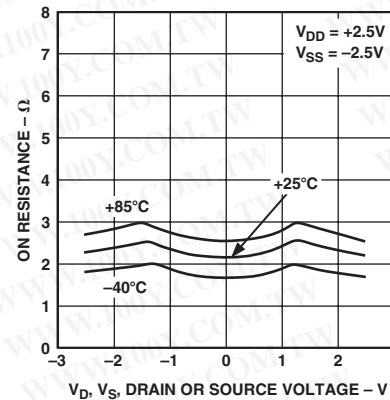

TPC 5. On Resistance as a Function of V_D (V_S) for Different Temperatures, Dual Supply

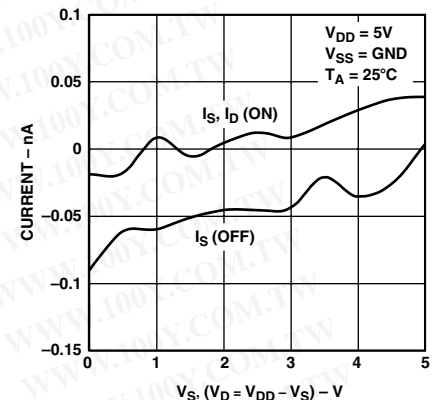

TPC 6. Leakage Currents as a Function of V_D (V_S)

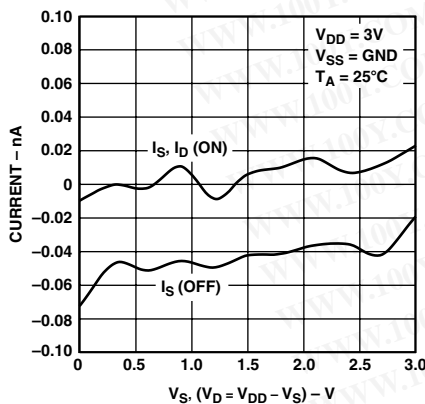

TPC 7. Leakage Currents as a Function of V_D (V_S)

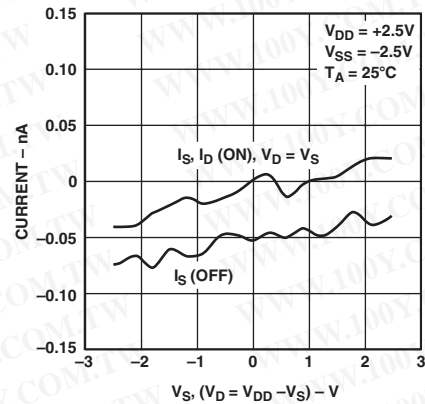

TPC 8. Leakage Currents as a Function of V_D (V_S)

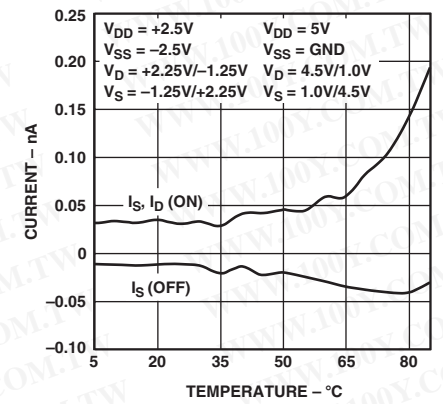

TPC 9. Leakage Currents as a Function of Temperature

勝特力材料 886-3-5753170
 勝特力电子(上海) 86-21-34970699
 勝特力电子(深圳) 86-755-83298787
[Http://www.100y.com.tw](http://www.100y.com.tw)

ADG733/ADG734

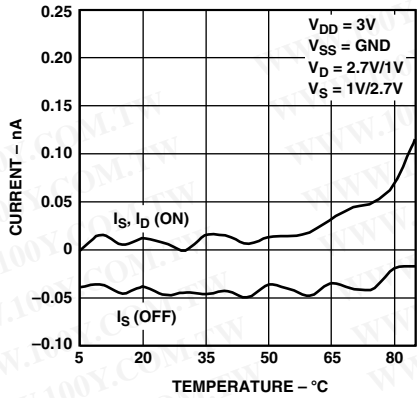

TPC 10. Leakage Currents as a Function of Temperature

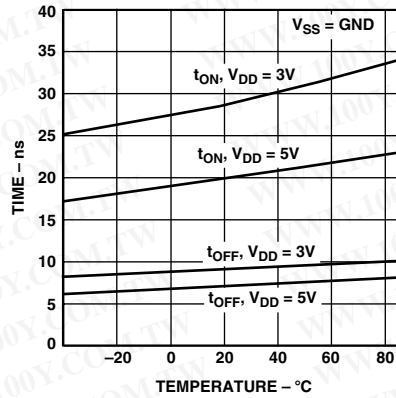

TPC 11. t_{ON}/t_{OFF} Times vs. Temperature

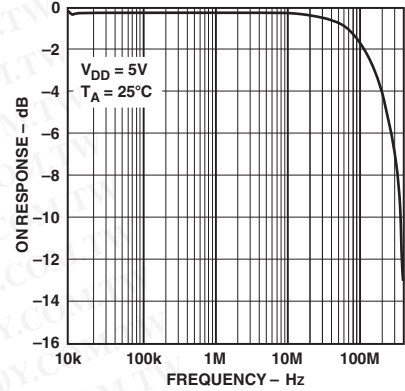

TPC 12. On Response vs. Frequency

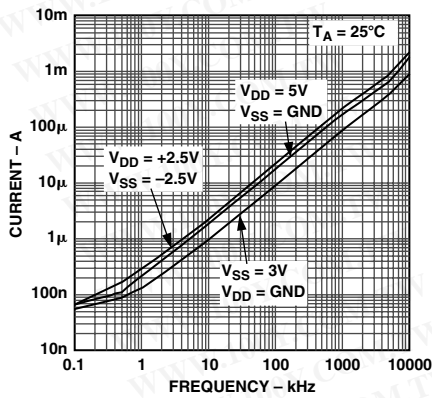

TPC 13. Input Current, I_{DD} vs. Switching Frequency

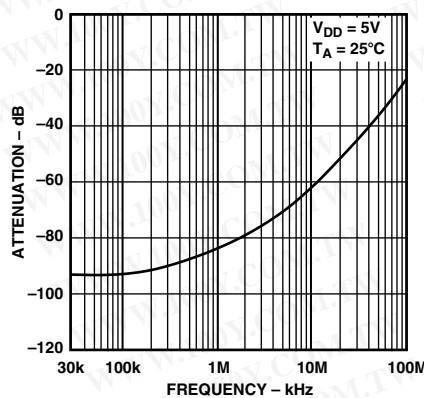

TPC 14. Off Isolation vs. Frequency

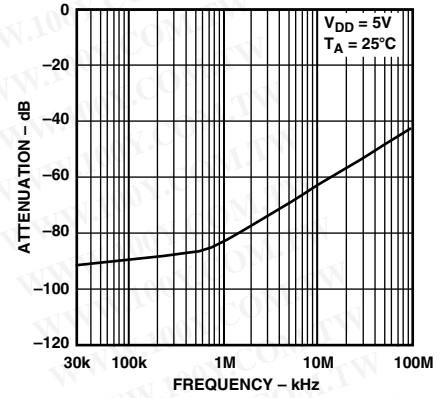

TPC 15. Crosstalk vs. Frequency

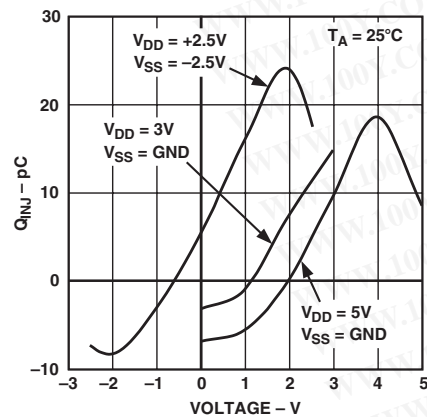

TPC 16. Charge Injection vs. Source Voltage

勝特力材料 886-3-5753170
 勝特力电子(上海) 86-21-34970699
 勝特力电子(深圳) 86-755-83298787
[Http://www.100y.com.tw](http://www.100y.com.tw)

Test Circuits

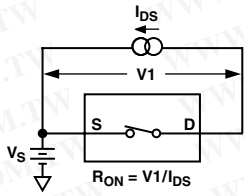

Test Circuit 1. On Resistance

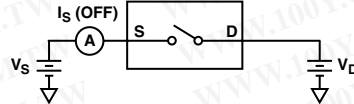

Test Circuit 2. I_S (OFF)

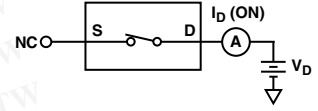

Test Circuit 3. I_D (ON)

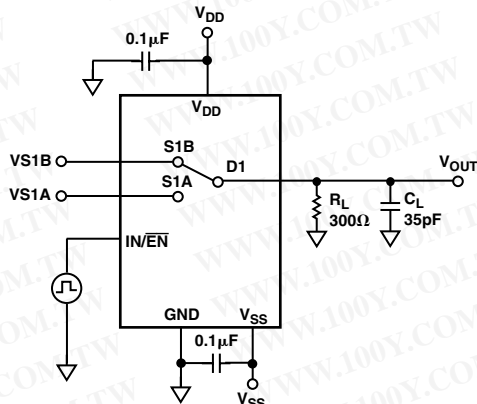

Test Circuit 4. Switching Times, t_{ON} , t_{OFF}

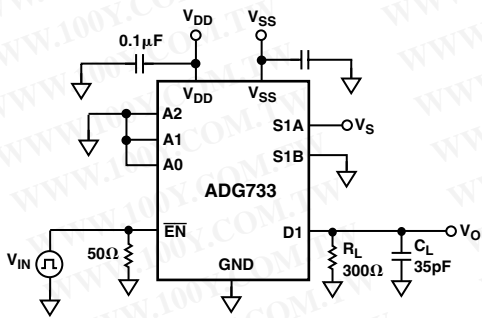
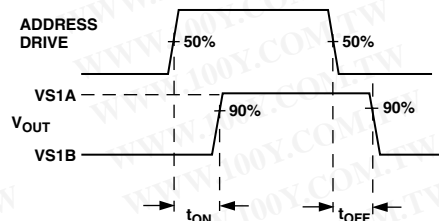

Test Circuit 5. Enable Delay, $t_{ON}(\overline{EN})$, $t_{OFF}(\overline{EN})$

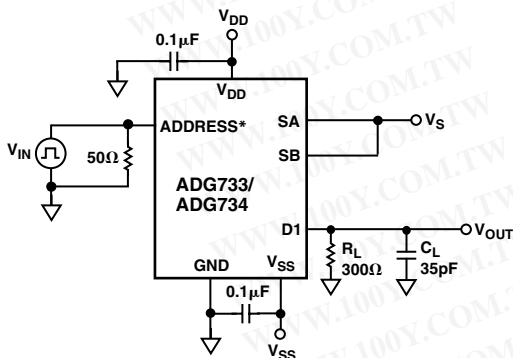
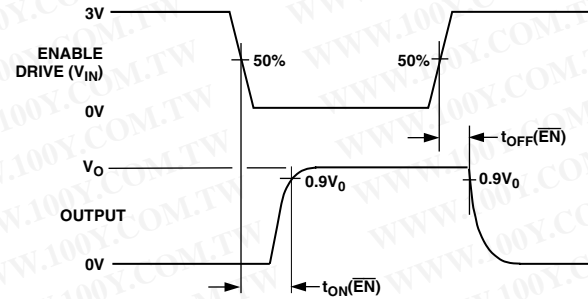

*A0, A1, A2 FOR ADG733, IN1-4 FOR ADG734

Test Circuit 6. Break-Before-Make Delay, t_{OPEN}

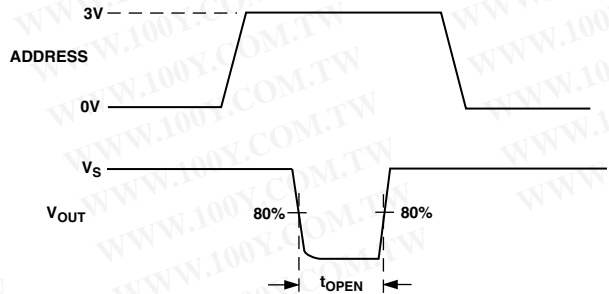

勝特力材料 886-3-5753170
 勝特力电子(上海) 86-21-34970699
 勝特力电子(深圳) 86-755-83298787
[Http://www.100y.com.tw](http://www.100y.com.tw)

ADG733/ADG734

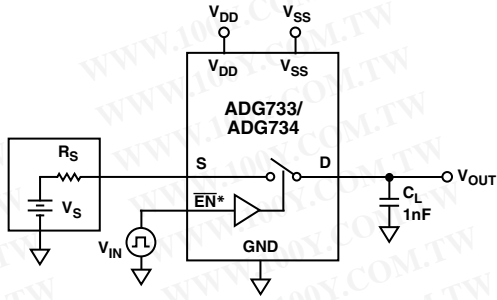

* IN1-4 FOR ADG734

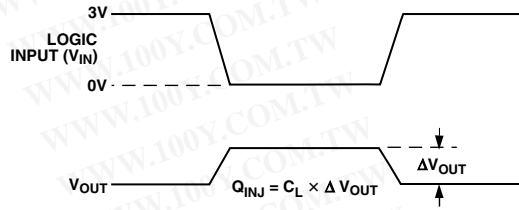

Test Circuit 7. Charge Injection

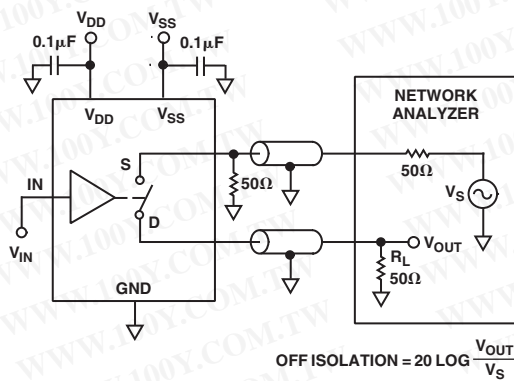

Test Circuit 8. Off Isolation

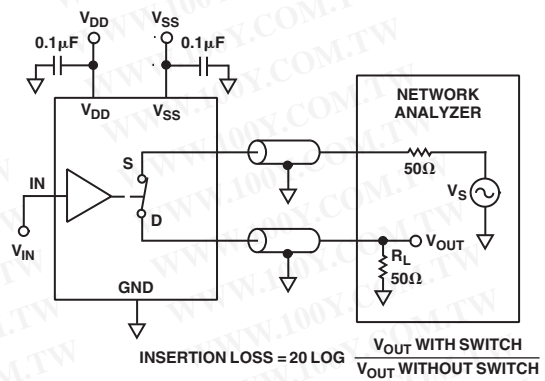

Test Circuit 10. Bandwidth

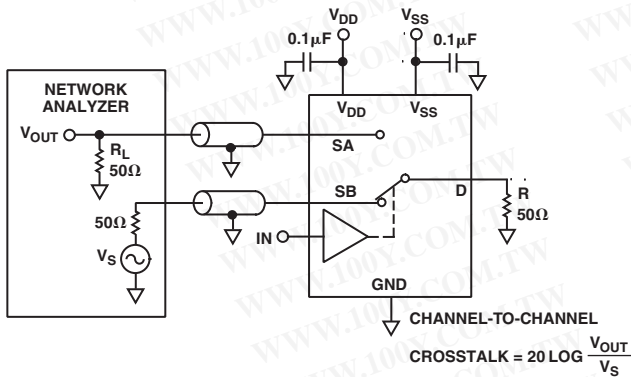

Test Circuit 9. Channel-to-Channel Crosstalk

勝特力材料 886-3-5753170
勝特力电子(上海) 86-21-34970699
勝特力电子(深圳) 86-755-83298787
Http://www.100y.com.tw

OUTLINE DIMENSIONS

16-Lead Thin Shrink Small Outline Package [TSSOP]
(RU-16)

Dimensions shown in millimeters

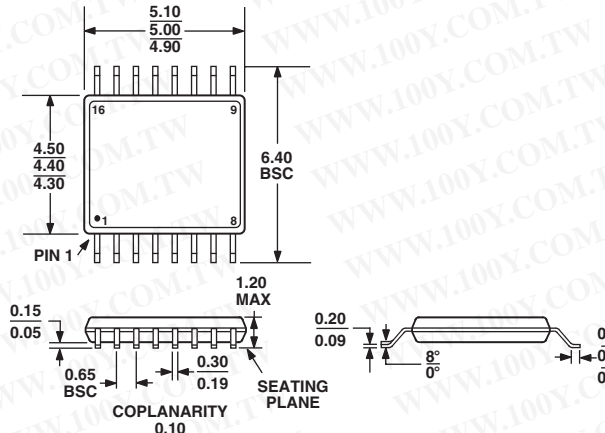

COMPLIANT TO JEDEC STANDARDS MO-153AB

20-Lead Thin Shrink Small Outline Package [TSSOP]
(RU-20)

Dimensions shown in millimeters

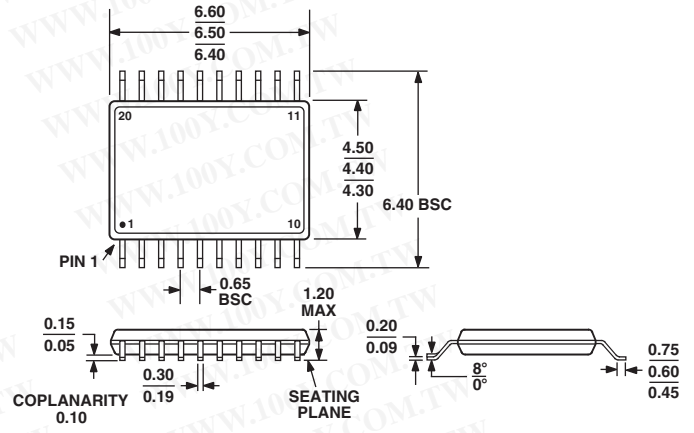

COMPLIANT TO JEDEC STANDARDS MO-153AC

16-Lead SOIC, 0.025 Lead Pitch [QSOP]
(RQ-16)

Dimensions shown in inches

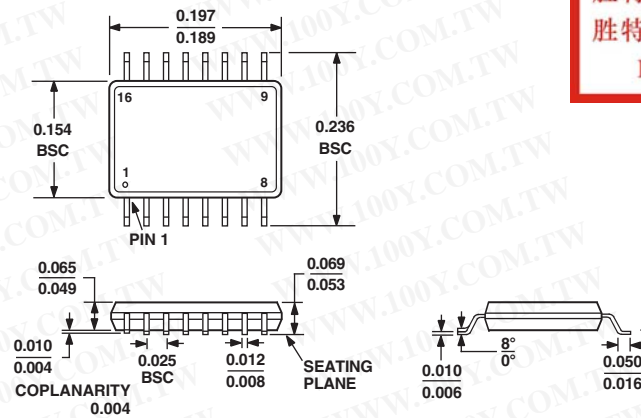

COMPLIANT TO JEDEC STANDARDS MO-137AB

勝特力材料 886-3-5753170
 勝特力电子(上海) 86-21-34970699
 勝特力电子(深圳) 86-755-83298787
[Http://www.100y.com.tw](http://www.100y.com.tw)

ADG733/ADG734

Revision History

勝特力材料 886-3-5753170
勝特力电子(上海) 86-21-34970699
勝特力电子(深圳) 86-755-83298787
[Http://www.100y.com.tw](http://www.100y.com.tw)

Location	Page
11/02—Data Sheet changed from REV. 0 to REV. A.	
Changes to FEATURES	1
Changes to PRODUCT HIGHLIGHTS	1
Changes to SPECIFICATIONS	2
Changes to ABSOLUTE MAXIMUM RATINGS Note 2	5
Changes to TERMINOLOGY table	6
Replaced TPCs 2, 5, 8, and 9	7
Edits to TPCs 6 and 7	7
Replaced TPC 12	8
Edits to TPCs 13 and 16	8
Replaced Test Circuits 8 and 9	10
Added Test Circuit 10	10
Updated OUTLINE DIMENSIONS	11

C01602-0-11/02(A)

PRINTED IN U.S.A.