

# ZRA125

## PRECISION 1.25 VOLT MICROPOWER VOLTAGE REFERENCE

### DESCRIPTION

The ZRA125 uses a bandgap circuit design to achieve a precision micropower voltage reference of 1.25 volts. The device is available in small outline surface mount packages, ideal for applications where space saving is important.

The ZRA125 design provides a stable voltage without an external capacitor and is stable with capacitive loads. The ZRA125 is recommended for operation between 50 $\mu$ A and 5mA and so is ideally suited to low power and battery powered applications.

Excellent performance is maintained to a suggested absolute maximum of 25mA, however the rugged design and 20 volt processing allows the reference to withstand transient effects and currents up to 200mA. Superior switching capability allows the device to reach stable operating conditions in only a few microseconds.

### FEATURES

- No stabilizing capacitor required
- Typical  $T_C$  30ppm/ $^{\circ}$ C
- Typical slope resistance 0.65 $\Omega$
- $\pm$  3% and 2% tolerance
- Industrial temperature range
- Operating current 50 $\mu$ A to 5mA
- Transient response, stable in less than 10 $\mu$ s
- Small outline SOT23 package

### APPLICATIONS

- Battery powered and portable equipment
- Metering and measurement systems
- Instrumentation
- Data acquisition systems
- Precision power supplies
- Test equipment

### SCHEMATIC DIAGRAM

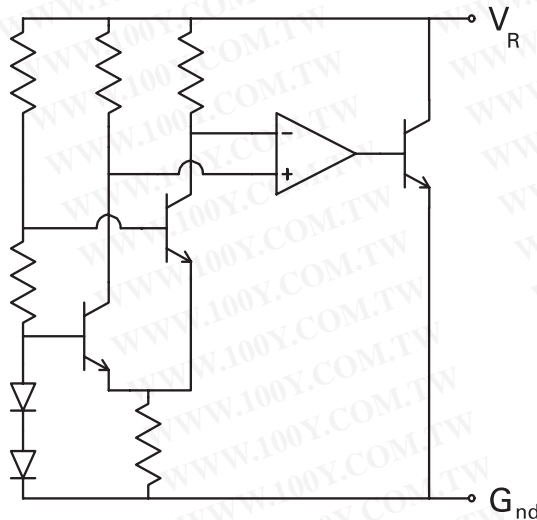

# ZRA125

## ABSOLUTE MAXIMUM RATINGS

Reverse current	25mA
Forward current	25mA
Operating temperature	-40 to 85°C
Storage temperature	-55 to 150°C

勝特力材料 886-3-5753170  
 勝特力电子(上海) 86-21-34970699  
 勝特力电子(深圳) 86-755-83298787  
[Http://www.100y.com.tw](http://www.100y.com.tw)

## POWER DISSIPATION (T<sub>amb</sub> = 25°C)

SOT23 330mW

## ELECTRICAL CHARACTERISTICS (at T<sub>amb</sub> = 25°C unless otherwise stated)

SYMBOL	PARAMETER	CONDITIONS	MIN.	TYP.	MAX.	TOL %	UNITS
V <sub>R</sub>	Reverse breakdown voltage	I <sub>R</sub> = 150μA	1.225 1.21	1.25 1.25	1.275 1.29	2 3	V V
I <sub>MIN</sub>	Minimum operating current			30	50		μA
I <sub>R</sub>	Recommended operating current		0.05		5		mA
T <sub>C</sub> <sup>(1)</sup>	Average reverse breakdown voltage temp. co.	I <sub>R</sub> (min) to I <sub>R</sub> (max)		30	90		ppm/°C
R <sub>S</sub> <sup>(2)</sup>	Slope resistance			0.65	2		Ω
Z <sub>R</sub>	Reverse dynamic impedance	I <sub>R</sub> = 1mA f = 100Hz I <sub>AC</sub> = 0.1I <sub>R</sub>		0.5	1		Ω
E <sub>N</sub>	Wideband Noise Voltage	I <sub>R</sub> = 150μA f = 100Hz to 10kHz		40			μV(rms)

### NOTES:

$$(1) T_C = \frac{V_R \text{ change} \times 1,000,000}{V_R \times \text{temperature change}}$$

T<sub>C</sub> is a characterized parameter not measured on individual devices.

$$(2) R_S = \frac{V_R \text{ change} (I_R(\text{min}) \text{ to } I_R(\text{max}))}{I_R(\text{max}) - I_R(\text{min})}$$

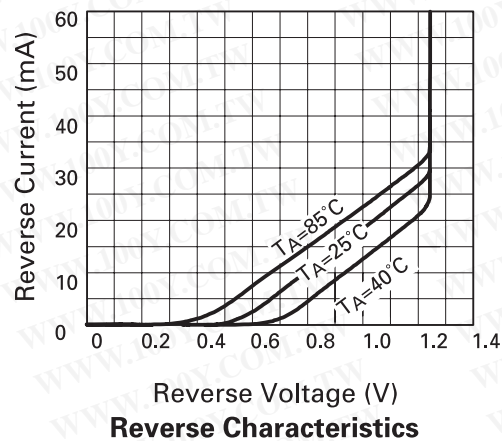

# ZRA125

## TYPICAL CHARACTERISTICS

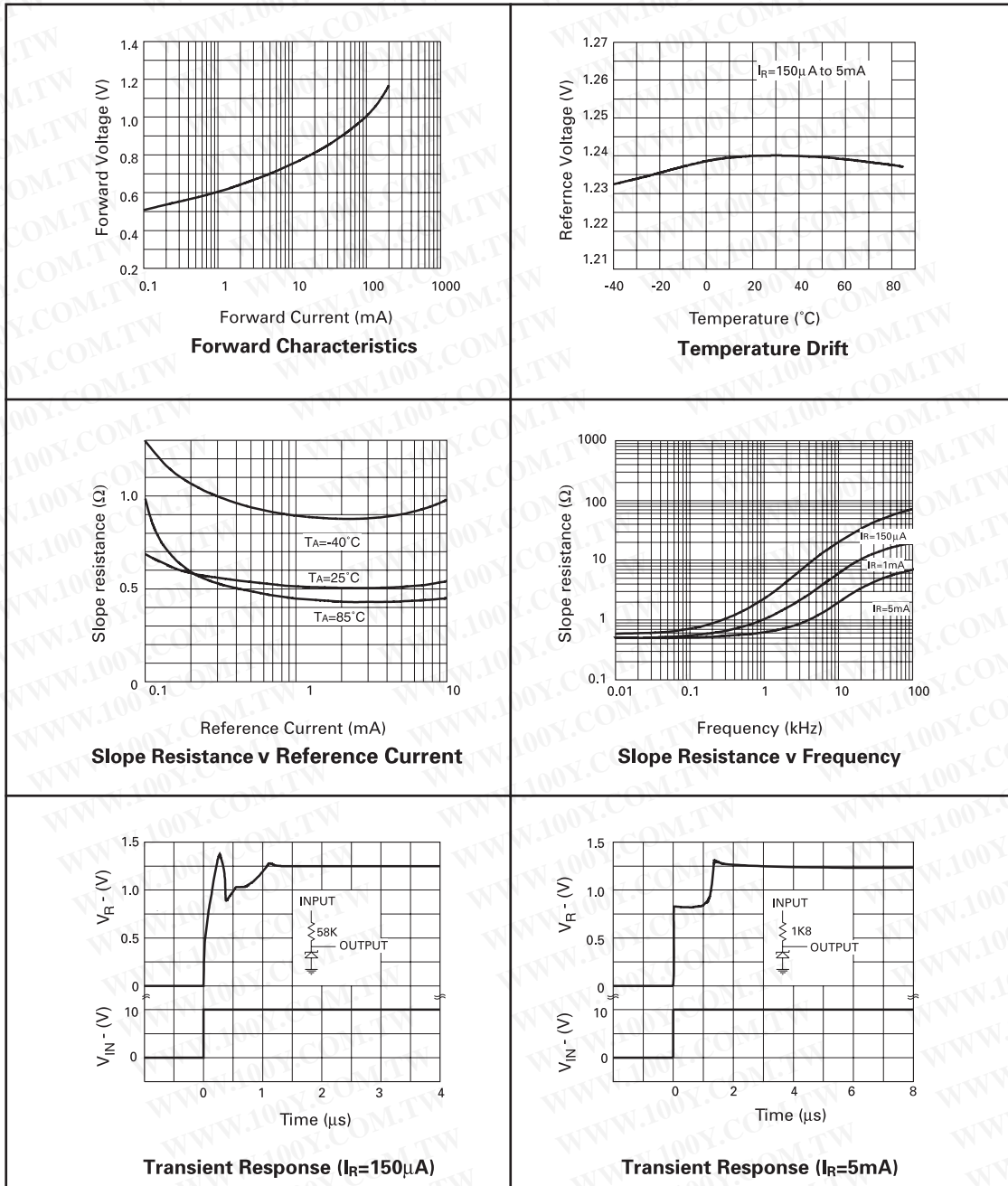

# ZRA125

## CONNECTION DIAGRAM

Package Suffix - F

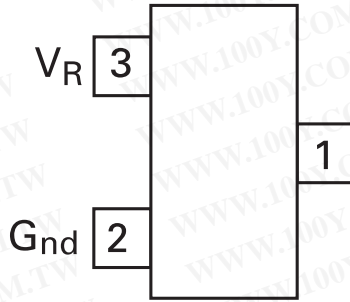

TOP VIEW

Pin 1 floating or connected to pin 2

## ORDERING INFORMATION

Part Number	Tol %	Package	Part Mark	Reel Size	Quantity per reel
ZRA125F02TA	2	SOT23	12B	7"	3,000
ZRA125F03TA	3	SOT23	12A	7"	3,000

# ZRA125

## PACKAGE OUTLINE

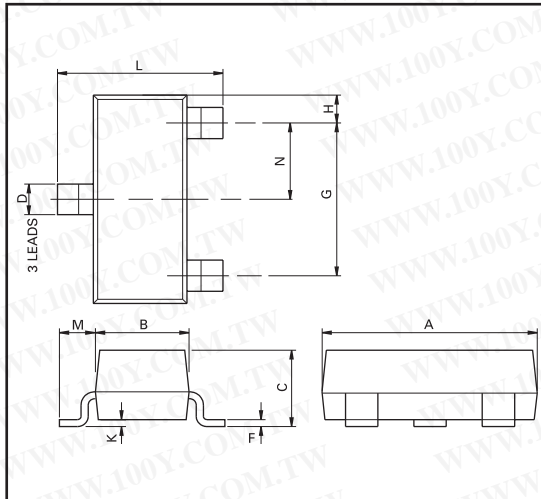

## PAD LAYOUT DETAILS

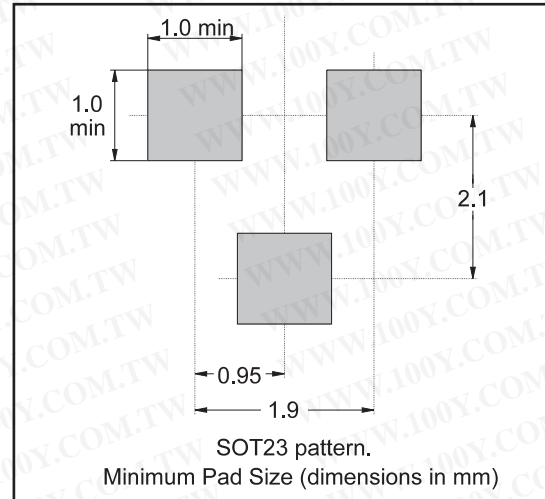

Controlling dimensions are in millimeters. Approximate conversions are given in inches

## PACKAGE DIMENSIONS

DIM	Millimeters		Inches		DIM	Millimeters		Inches	
	Min	Max	Min	Max		Min	Max	Max	Max
A	2.67	3.05	0.105	0.120	H	0.33	0.51	0.013	0.020
B	1.20	1.40	0.047	0.055	K	0.01	0.10	0.0004	0.004
C	—	1.10	—	0.043	L	2.10	2.50	0.083	0.0985
D	0.37	0.53	0.015	0.021	M	0.45	0.64	0.018	0.025
F	0.085	0.15	0.0034	0.0059	N	0.95 NOM		0.0375 NOM	
G	1.90 NOM		0.075 NOM		—	—		—	

勝特力材料 886-3-5753170  
 勝特力电子(上海) 86-21-34970699  
 勝特力电子(深圳) 86-755-83298787  
[Http://www.100y.com.tw](http://www.100y.com.tw)