

SI-8400L/8500L Series Separate Excitation Switching Mode Regulator ICs with Coil

Features

- Switching ICs/Coil combined type
- Requires only 2 discrete components
- Low switching noise
- No heatsink required
- Built-in overcurrent and thermal protection circuits
- Built-in soft start circuit (Output ON/OFF available)...SI-8500L Series

Applications

- Telephone power supplies
- Onboard local power supplies

Lineup

Part Number	SI-8401L	SI-8501L
V _o (V)	5.0	5.0
I _o (A)	0.5	1.0

Absolute Maximum Ratings

Parameter	Symbol	Ratings		Unit
		SI-8400L	SI-8500L	
DC Input Voltage	V _{IN}	35		V
Power Dissipation	P _D	1.25	3	W
Junction Temperature	T _J	+100		°C
Storage Temperature	T _{stg}	-25 to +85		°C

Recommended Operating Conditions

Parameter	Symbol	Ratings		Unit
		SI-8401L		
DC Input Voltage Range	V _{IN}	7 to 33		V
Output Current Range	I _o	0 to 0.5		A
Operating Temperature Range	T _{op}	-20 to +85		°C

Parameter	Symbol	Ratings		Unit
		SI-8501L		
DC Input Voltage Range	V _{IN}	7 to 33		V
Output Current Range	I _o	0 to 1.0		A
Operating Temperature Range	T _{op}	-20 to +85		°C

Electrical Characteristics

(T_a=25°C)

Parameter	Symbol	Ratings			Unit
		SI-8401L			
		min.	typ.	max.	
Output Voltage	V _o	4.80	5.00	5.20	V
	Conditions	V _{IN} =20V, I _o =0.3A			
Efficiency	η	80			%
	Conditions	V _{IN} =20V, I _o =0.3A			
Oscillation Frequency	f	60			kHz
	Conditions	V _{IN} =20V, I _o =0.3A			
Line Regulation	ΔV _{OLINE}	80			mV
	Conditions	V _{IN} =10 to 30V, I _o =0.3A			
Load Regulation	ΔV _{OLOAD}	30			mV
	Conditions	V _{IN} =20V, I _o =0.1 to 0.4A			
Temperature Coefficient of Output Voltage	ΔV _o /ΔT _a	±0.5			mV/°C
Switching Ripple Voltage (C ₂ =470μF)	ΔV _r	20			mV _{p-p}
	Conditions	V _{IN} =20V, I _o =0.3A			
Overcurrent Protection Starting Current	I _{s1}	0.55			A
	Conditions	V _{IN} =10V			

(T_a=25°C)

Parameter	Symbol	Ratings			Unit
		SI-8501L			
		min.	typ.	max.	
Output Voltage	V _o	4.80	5.00	5.20	V
	Conditions	V _{IN} =20V, I _o =0.5A			
Efficiency	η	83			%
	Conditions	V _{IN} =20V, I _o =0.5A			
Oscillation Frequency	f	60			kHz
	Conditions	V _{IN} =20V, I _o =0.5A			
Line Regulation	ΔV _{OLINE}	70			mV
	Conditions	V _{IN} =10 to 30V, I _o =0.5A			
Load Regulation	ΔV _{OLOAD}	30			mV
	Conditions	V _{IN} =20V, I _o =0.2 to 0.8A			
Temperature Coefficient of Output Voltage	ΔV _o /ΔT _a	±0.5			mV/°C
Switching Ripple Voltage (C ₂ =470μF)	ΔV _r	45			mV _{p-p}
	Conditions	V _{IN} =20V, I _o =0.5A			
Overcurrent Protection Starting Current	I _{s1}	1.1			A
	Conditions	V _{IN} =18V			

External Dimensions (Non-package type [EI-12.5 core/EI-19 core])

(Unit : mm)

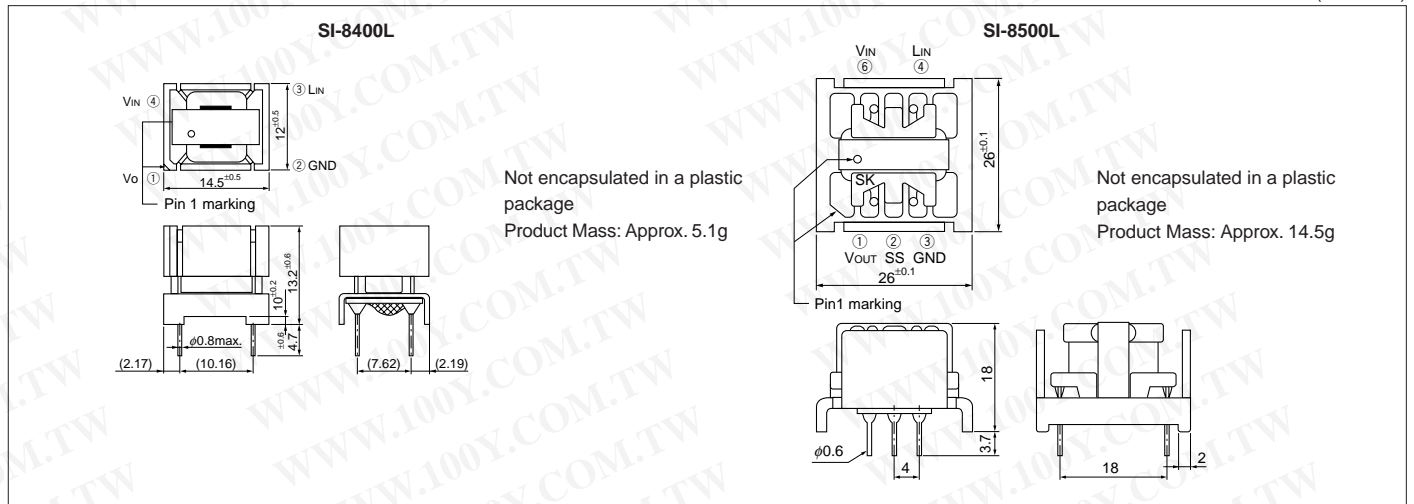

Block Diagram

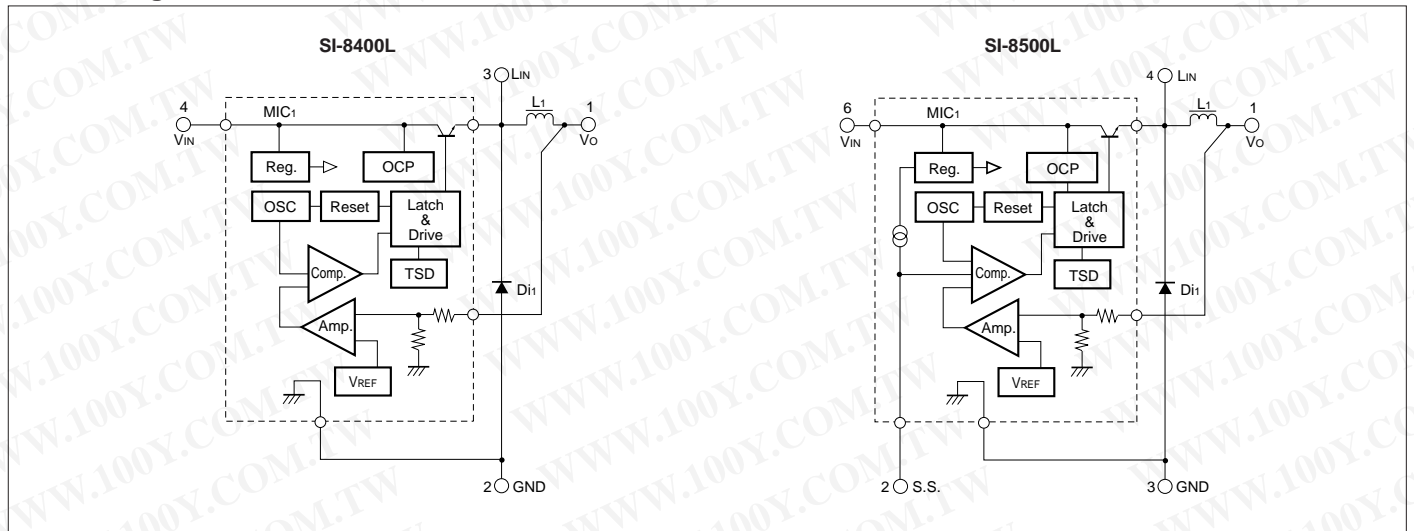

Typical Connection Diagram

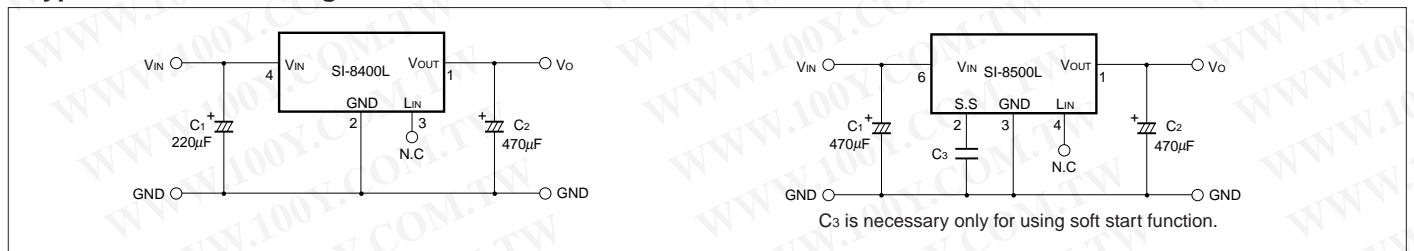

Ta-Pd Characteristics

