



# STM6321, STM6322, STM6821, STM6822, STM6823, STM6824, STM6825

## 5-pin supervisor with watchdog timer and push-button reset

Datasheet –production data

### Features

- Precision  $V_{CC}$  monitoring of 5, 3.3, 3, or 2.5 V power supplies
- $\overline{RST}$  outputs (active low, push-pull or open drain)
- RST outputs (active high, push-pull)
- Reset pulse width of 1.4 ms, 200 ms and 240 ms (typ.)
- Watchdog timeout period of 1.6 s (typ.)
- Manual reset input ( $\overline{MR}$ )
- Low supply current - 3  $\mu$ A (typ.)
- Guaranteed  $\overline{RST}$  (RST) assertion down to  $V_{CC} = 1.0$  V
- Operating temperature:  $-40$  to  $+85$  °C (industrial grade)
- RoHS compliance  
Lead-free components are compliant with the RoHS directive

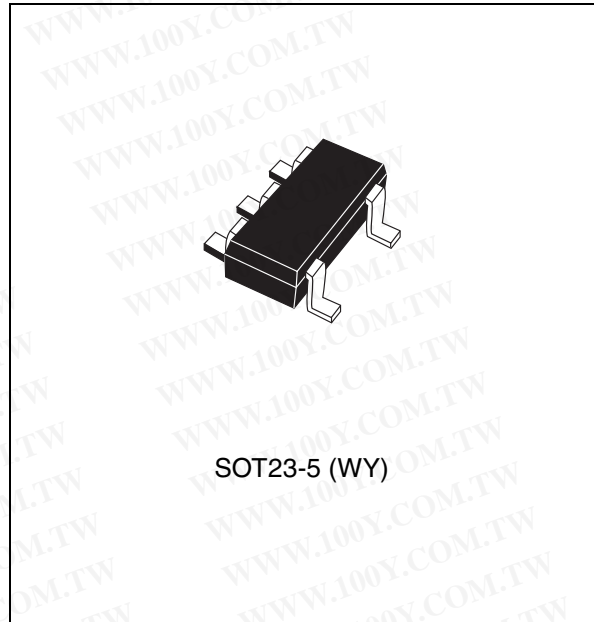


Table 1. Device summary

Part number	Watchdog input	Manual reset input	Reset output		
			Active low (push-pull)	Active high (push-pull)	Active low (open drain)
STM6321	✓			✓	✓
STM6322		✓		✓	✓
STM6821	✓	✓		✓	
STM6822	✓	✓			✓
STM6823	✓	✓	✓		
STM6824	✓		✓	✓	
STM6825		✓	✓	✓	

勝特力材料 886-3-5753170  
勝特力电子(上海) 86-21-34970699  
勝特力电子(深圳) 86-755-83298787  
[Http://www.100y.com.tw](http://www.100y.com.tw)

# Contents

<b>1</b>	<b>Description</b> .....	<b>5</b>
1.1	Pin descriptions .....	7
1.1.1	Active low, push-pull reset output ( $\overline{\text{RST}}$ ) - 6823/6824/6825 .....	7
1.1.2	Active low, open drain reset output ( $\overline{\text{RST}}$ ) - STM6321/6322/6822 .....	7
1.1.3	Push-button reset input ( $\overline{\text{MR}}$ ) .....	7
1.1.4	Watchdog input (WDI) .....	7
1.1.5	Active high reset output (RST) .....	7
<b>2</b>	<b>Operation</b> .....	<b>10</b>
2.1	Reset output .....	10
2.2	Open drain $\overline{\text{RST}}$ output .....	10
2.3	Push-button reset input (STM6322/6821/6822/6823/6825) .....	11
2.4	Watchdog input (STM6321/6821/6822/6823/6824) .....	11
2.5	Applications information .....	11
2.5.1	Watchdog input current .....	11
2.5.2	Ensuring a valid reset output down to $V_{\text{CC}} = 0 \text{ V}$ .....	11
2.6	Interfacing to microprocessors with bidirectional reset pins .....	12
<b>3</b>	<b>Typical operating characteristics</b> .....	<b>13</b>
<b>4</b>	<b>Maximum ratings</b> .....	<b>18</b>
<b>5</b>	<b>DC and AC parameters</b> .....	<b>19</b>
<b>6</b>	<b>Package mechanical data</b> .....	<b>21</b>
<b>7</b>	<b>Package mechanical data</b> .....	<b>24</b>
<b>8</b>	<b>Part numbering</b> .....	<b>27</b>
<b>9</b>	<b>Revision history</b> .....	<b>30</b>

## List of tables

Table 1.	Device summary . . . . .	1
Table 2.	Signal names . . . . .	5
Table 3.	Pin functions . . . . .	7
Table 4.	Absolute maximum ratings . . . . .	18
Table 5.	Operating and AC measurement conditions . . . . .	19
Table 6.	DC and AC characteristic . . . . .	21
Table 7.	SOT23-5 – 5-lead small outline transistor package mechanical data . . . . .	25
Table 8.	Carrier tape dimensions for SOT23-5 package . . . . .	26
Table 9.	Ordering information scheme . . . . .	27
Table 10.	Marking description . . . . .	28
Table 11.	Document revision history . . . . .	30

## List of figures

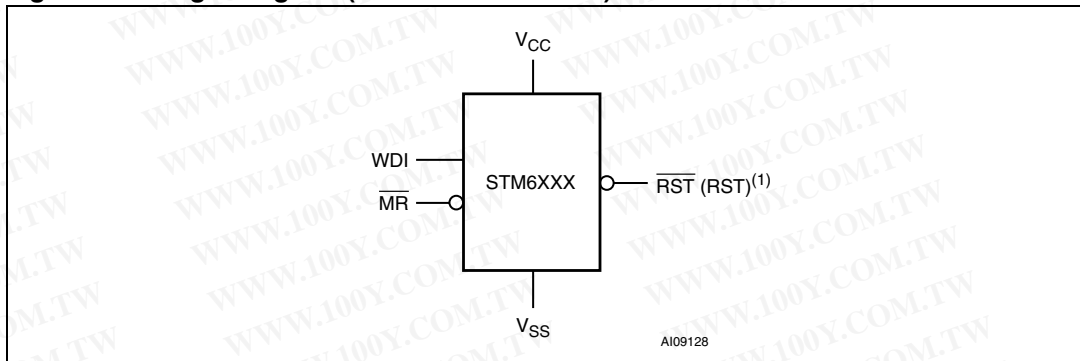
Figure 1.	Logic diagram (STM6821/6822/6823)	5
Figure 2.	Logic diagram (STM6321/6322/6824/6825)	5
Figure 3.	STM6822/6823 SOT23-5 connections	6
Figure 4.	STM6821 SOT23-5 connections	6
Figure 5.	STM6322/6825 SOT23-5 connections	6
Figure 6.	STM6321/6824 SOT23-5 connections	6
Figure 7.	Block diagram (STM6821/6822/6823)	8
Figure 8.	Block diagram (STM6321/6824)	8
Figure 9.	Block diagram (STM6322/6825)	8
Figure 10.	Hardware hookup	9
Figure 11.	STM6321/6322/6822 open drain $\overline{RST}$ output with multiple supplies	10
Figure 12.	Ensuring $\overline{RST}$ valid to $V_{CC} = 0$ , (active low push-pull outputs)	12
Figure 13.	Ensuring RST valid to $V_{CC} = 0$ , (active high, push-pull outputs)	12
Figure 14.	Interfacing to microprocessors with bidirectional reset I/O	12
Figure 15.	$V_{CC}$ -to-reset output delay vs. temperature	13
Figure 16.	Supply current vs. temperature	13
Figure 17.	$\overline{MR}$ -to-reset output delay vs. temperature	14
Figure 18.	Normalized power-up $t_{rec}$ vs. temperature	14
Figure 19.	Normalized reset threshold voltage vs. temperature	15
Figure 20.	Normalized power-up watchdog timeout period	15
Figure 21.	Voltage output low vs. $I_{SINK}$	16
Figure 22.	Voltage output high vs. $I_{SOURCE}$	16
Figure 23.	Maximum transient duration vs. reset threshold overdrive	17
Figure 24.	AC testing input/output waveforms	19
Figure 25.	$\overline{MR}$ timing waveform	19
Figure 26.	Watchdog timing	20
Figure 27.	SOT23-5 – 5-lead small outline transistor package mechanical drawing	25
Figure 28.	Carrier tape for SOT23-5 package	26

# 1 Description

The STM6xxx supervisors are self-contained devices which provide microprocessor supervisory functions. A precision voltage reference and comparator monitors the  $V_{CC}$  input for an out-of-tolerance condition. When an invalid  $V_{CC}$  condition occurs, the reset output ( $\overline{RST}$ ) is forced low (or high in the case of RST). These devices also offer a watchdog timer (except for STM6322/6825) and/or a push-button ( $\overline{MR}$ ) reset input.

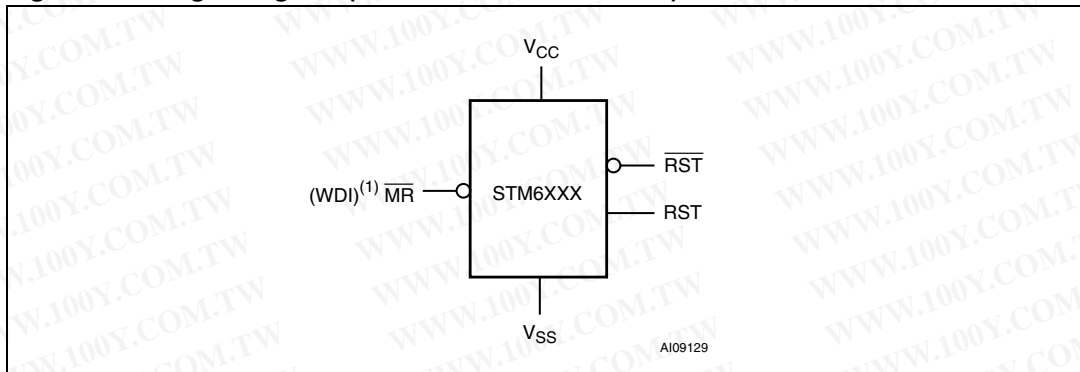
These devices are available in a standard 5-pin SOT23 package.

**Figure 1. Logic diagram (STM6821/6822/6823)**



1. For STM6821 only.

**Figure 2. Logic diagram (STM6321/6322/6824/6825)**

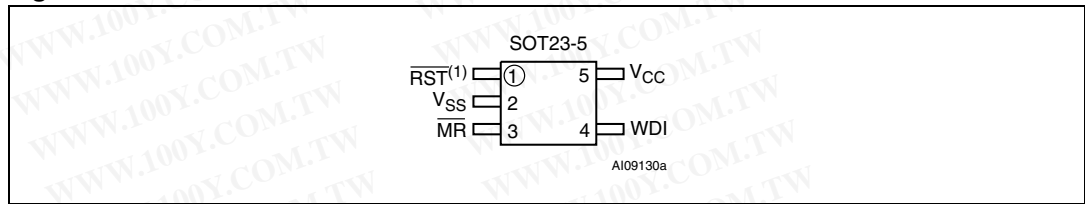


1. For STM6321/6824.

**Table 2. Signal names**

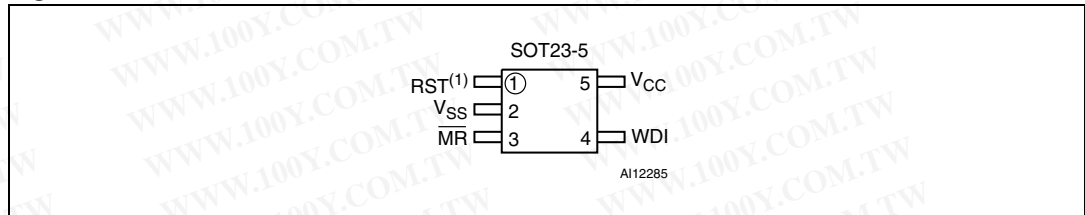
Name	Function
$\overline{MR}$	Push-button reset input
WDI	Watchdog input
$\overline{RST}$	Active low reset output
RST	Active high reset output
$V_{CC}$	Supply voltage
$V_{SS}$	Ground

**Figure 3. STM6822/6823 SOT23-5 connections**



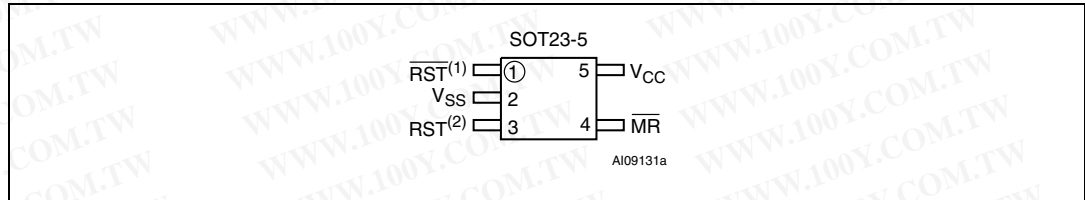
1. Open drain for STM6822.

**Figure 4. STM6821 SOT23-5 connections**



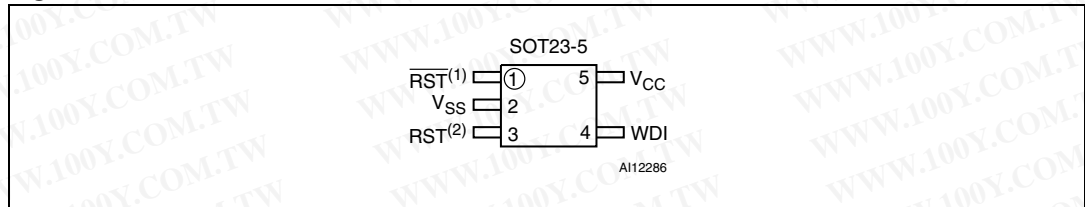
1. Push-pull only.

**Figure 5. STM6322/6825 SOT23-5 connections**



1. Open drain for STM6322.
2. Push-pull only.

**Figure 6. STM6321/6824 SOT23-5 connections**



1. Open drain for STM6321.
2. Push-pull only.

## 1.1 Pin descriptions

### 1.1.1 Active low, push-pull reset output ( $\overline{RST}$ ) - 6823/6824/6825

Pulses low when triggered, and stays low whenever  $V_{CC}$  is below the reset threshold or when  $\overline{MR}$  is a logic low. It remains low for  $t_{rec}$  after either  $V_{CC}$  rises above the reset threshold, the watchdog triggers a reset, or  $\overline{MR}$  goes from low to high.

### 1.1.2 Active low, open drain reset output ( $\overline{RST}$ ) - STM6321/6322/6822

Pulses low when triggered, and stays low whenever  $V_{CC}$  is below the reset threshold or when  $\overline{MR}$  is a logic low. It remains low for  $t_{rec}$  after either  $V_{CC}$  rises above the reset threshold, the watchdog triggers a reset, or  $\overline{MR}$  goes from low to high. Connect a pull-up resistor to supply voltage.

### 1.1.3 Push-button reset input ( $\overline{MR}$ )

A logic low on  $\overline{MR}$  asserts the reset output. Reset remains asserted as long as  $\overline{MR}$  is low and for  $t_{rec}$  after  $\overline{MR}$  returns high. This active low input has an internal 52 k $\Omega$  pull-up. It can be driven from a TTL or CMOS logic line, or shorted to ground with a switch. Leave open if unused.

### 1.1.4 Watchdog input (WDI)

If WDI remains high or low for at least 1.6 s, the internal watchdog timer expires and reset is asserted. The internal watchdog timer clears while reset is asserted or when WDI sees a rising or falling edge. The watchdog function **CAN** be disabled if WDI is left unconnected or is connected to a tristate buffer output.

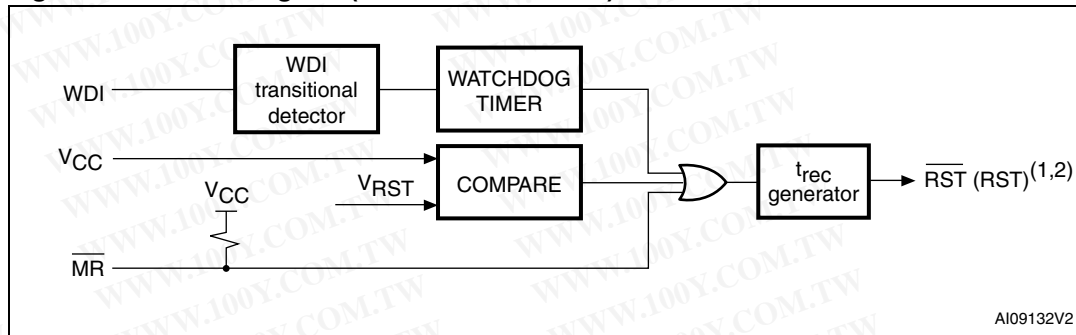
### 1.1.5 Active high reset output (RST)

Active high, push-pull reset output; inverse of  $\overline{RST}$ .

Table 3. Pin functions

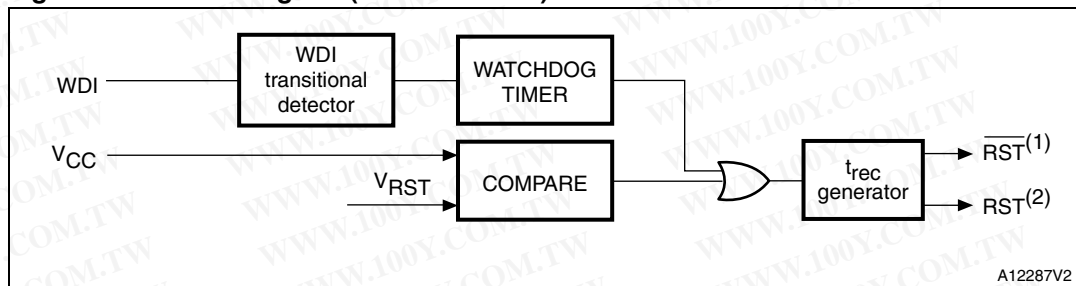
Pin				Name	Function
STM6822 STM6823	STM6821	STM6321 STM6824	STM6322 STM6825		
1	—	1	1	$\overline{RST}$	Active low reset output
3	3	—	4	$\overline{MR}$	Push-button reset input
4	4	4	—	WDI	Watchdog Input
—	1	3	3	RST	Active high reset output
5	5	5	5	$V_{CC}$	Supply voltage
2	2	2	2	$V_{SS}$	Ground

Figure 7. Block diagram (STM6821/6822/6823)



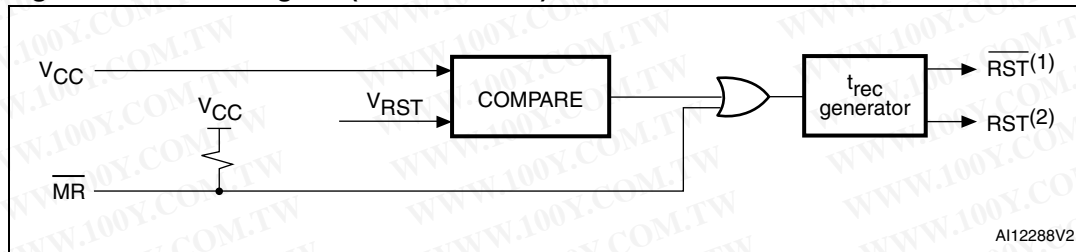
1. Push-pull for STM6823, open drain for STM6822.
2. Active high (push-pull) for STM6821.

Figure 8. Block diagram (STM6321/6824)



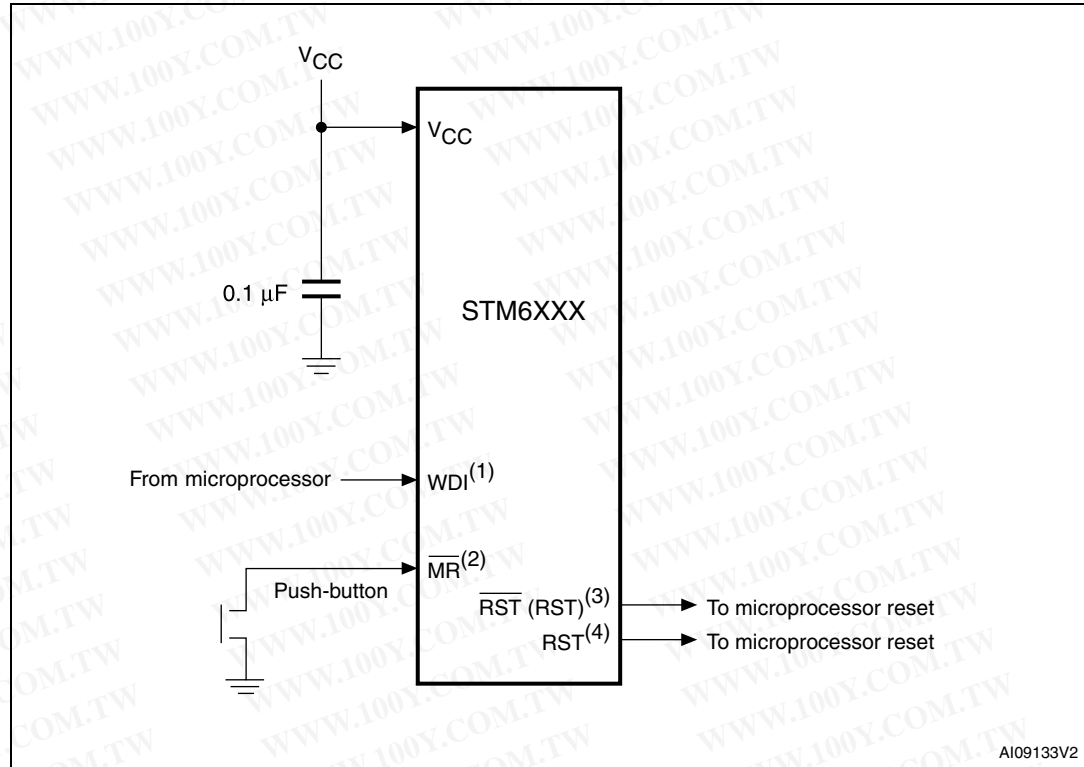
3. Active low (open drain) for STM6321, active low (push-pull) for STM6824.
4. Push-pull only.

Figure 9. Block diagram (STM6322/6825)



1. Active low (open drain) for STM6322, active low (push-pull) for STM6825.
2. Push-pull only.

Figure 10. Hardware hookup



1. For STM6321/6821/6822/6823/6824.
2. For STM6322/6821/6822/6823/6825.
3. For STM6821/ (RST output only).
4. For STM6321/6322/6824/6825 (both RST and  $\overline{\text{RST}}$  outputs).

## 2 Operation

### 2.1 Reset output

The STM6xxx supervisor asserts a reset signal to the MCU whenever  $V_{CC}$  goes below the reset threshold ( $V_{RST}$ ), a watchdog timeout occurs, or when the push-button reset input ( $\overline{MR}$ ) is taken low. Reset is guaranteed valid for  $V_{CC} < V_{RST}$  down to  $V_{CC} = 1\text{ V}$  for  $T_A = 0$  to  $85\text{ }^\circ\text{C}$ .

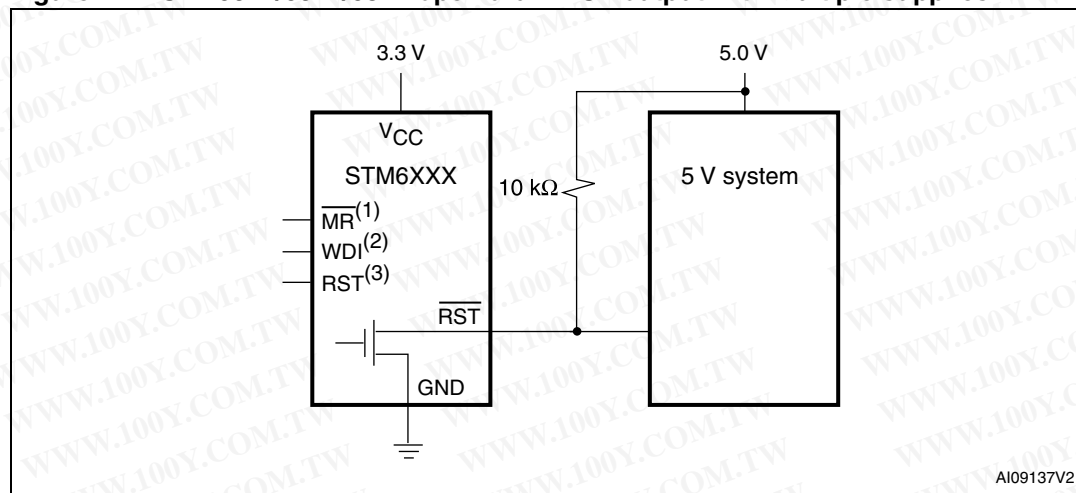
During power-up, once  $V_{CC}$  exceeds the reset threshold an internal timer keeps reset low for the reset timeout period,  $t_{rec}$ . After this interval reset is de-asserted.

Each time  $\overline{RST}$  is asserted, it stays low for at least the reset timeout period ( $t_{rec}$ ). Any time  $V_{CC}$  goes below the reset threshold the internal timer clears. The reset timer starts when  $V_{CC}$  returns above the reset threshold.

### 2.2 Open drain $\overline{RST}$ output

The STM6321/6322/6822 have an active low, open drain reset output. This output structure will sink current when  $\overline{RST}$  is asserted. Connect a pull-up resistor from  $\overline{RST}$  to any supply voltage up to 6 V (see [Figure 11](#)). Select a resistor value large enough to register a logic low, and small enough to register a logic high while supplying all input current and leakage paths connected to the reset output line. A 10 k $\Omega$  pull-up resistor is sufficient in most applications.

**Figure 11. STM6321/6322/6822 open drain  $\overline{RST}$  output with multiple supplies**



1. STM6322/6822.
2. STM6321/6822.
3. STM6321/6322.

## 2.3 Push-button reset input (STM6322/6821/6822/6823/6825)

A logic low on  $\overline{MR}$  asserts reset. Reset remains asserted while  $\overline{MR}$  is low, and for  $t_{rec}$  (see [Figure 25 on page 19](#)) after it returns high. The MR input has an internal 52 k $\Omega$  pull-up resistor, allowing it to be left open if not used. This input can be driven with TTL/CMOS-logic levels or with open drain/collector outputs. Connect a normally open momentary switch from  $\overline{MR}$  to GND to create a manual reset function; external debounce circuitry is not required. If  $\overline{MR}$  is driven from long cables or the device is used in a noisy environment, connect a 0.1  $\mu$ F capacitor from MR to GND to provide additional noise immunity.  $\overline{MR}$  may float, or be tied to  $V_{CC}$  when not used.

## 2.4 Watchdog input (STM6321/6821/6822/6823/6824)

The watchdog timer can be used to detect an out-of-control MCU. If the MCU does not toggle the Watchdog Input (WDI) within  $t_{WD}$  (1.6 sec), the reset is asserted. The internal watchdog timer is cleared by either:

1. a reset pulse, or
2. by toggling WDI (high to low or low to high), which can detect pulses as short as 50 ns.

The timer remains cleared and does not count for as long as reset is asserted. As soon as reset is released, the timer starts counting.

*Note:* The watchdog function may be disabled by floating WDI or tristating the driver connected to WDI. When tristated or disconnected, the maximum allowable leakage current is 10  $\mu$ A and the maximum allowable load capacitance is 200 pF.

## 2.5 Applications information

### 2.5.1 Watchdog input current

The WDI input is internally driven through a buffer and series resistor from the watchdog counter. For minimum watchdog input current (minimum overall power consumption), leave WDI low for the majority of the watchdog timeout period. When high, WDI can draw as much as 160  $\mu$ A. Pulsing WDI high at a low duty cycle will reduce the effect of the large input current. When WDI is left unconnected, the watchdog timer is serviced within the watchdog timeout period by a low-high-low pulse from the counter chain.

### 2.5.2 Ensuring a valid reset output down to $V_{CC} = 0$ V

The STM6xxx supervisors are guaranteed to operate properly down to  $V_{CC} = 1$  V. In applications that require valid reset levels down to  $V_{CC} = 0$ , a pull-down resistor to active low outputs (push/pull only, see [Figure 12 on page 12](#)) and a pull-up resistor to active high outputs (push/pull only, see [Figure 13 on page 12](#)) will ensure that the reset line is valid while the reset output can no longer sink or source current. This scheme does not work with the open drain outputs of the STM6321/6322/6822.

The resistor value used is not critical, but it must be large enough not to load the reset output when  $V_{CC}$  is above the reset threshold. For most applications, 100 k $\Omega$  is adequate.

Figure 12. Ensuring  $\overline{\text{RST}}$  valid to  $V_{\text{CC}} = 0$ , (active low push-pull outputs)

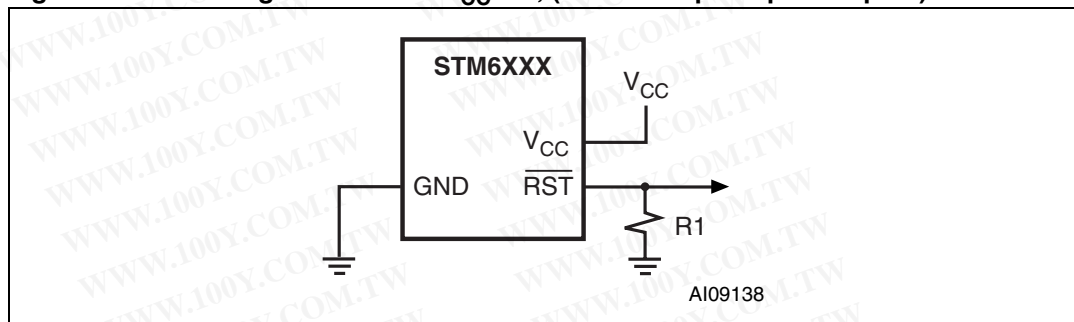
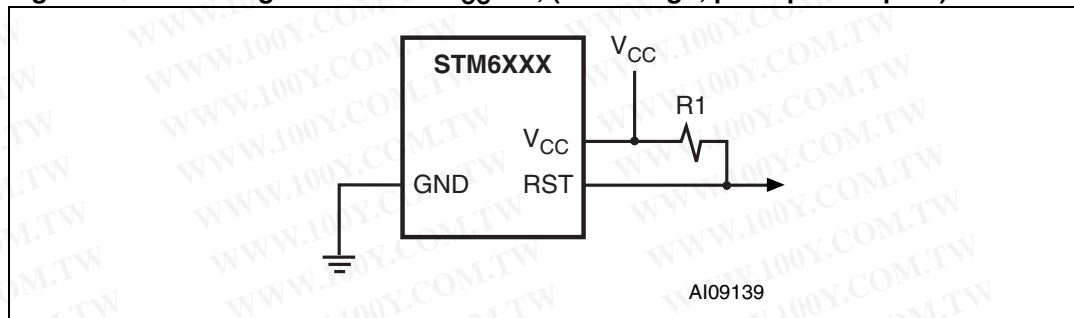


Figure 13. Ensuring RST valid to  $V_{\text{CC}} = 0$ , (active high, push-pull outputs)

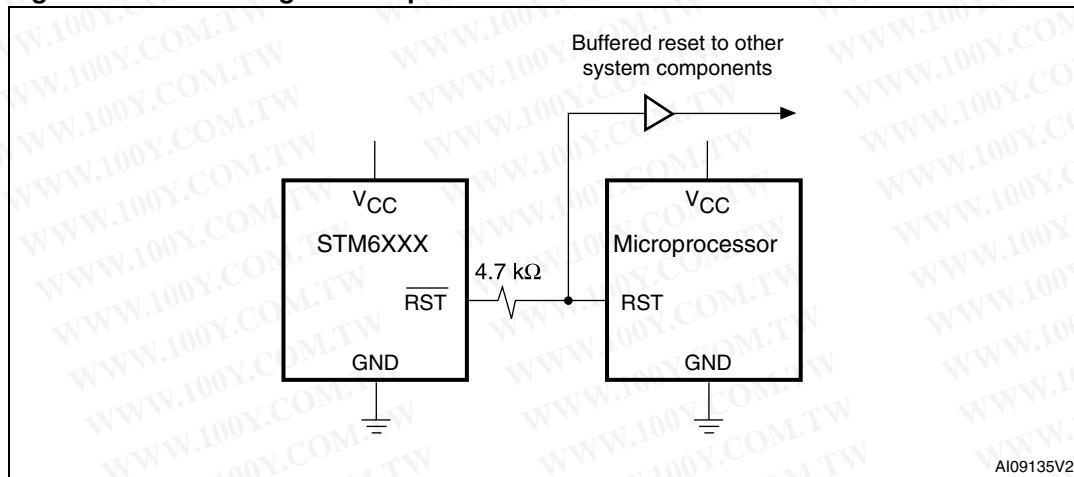


1. This configuration does not work on open drain outputs of the STM6321/6322/6822.

## 2.6 Interfacing to microprocessors with bidirectional reset pins

Microprocessors with bidirectional reset pins can contend with the STM6321/6322/6821/6822/6823/6824/6825 reset output. For example, if the reset output is driven high and the microprocessor wants to pull it low, signal contention will result. To prevent this from occurring, connect a 4.7 kΩ resistor between the reset output and the microprocessor's reset I/O as in [Figure 14](#).

Figure 14. Interfacing to microprocessors with bidirectional reset I/O



### 3 Typical operating characteristics

Figure 15.  $V_{CC}$ -to-reset output delay vs. temperature

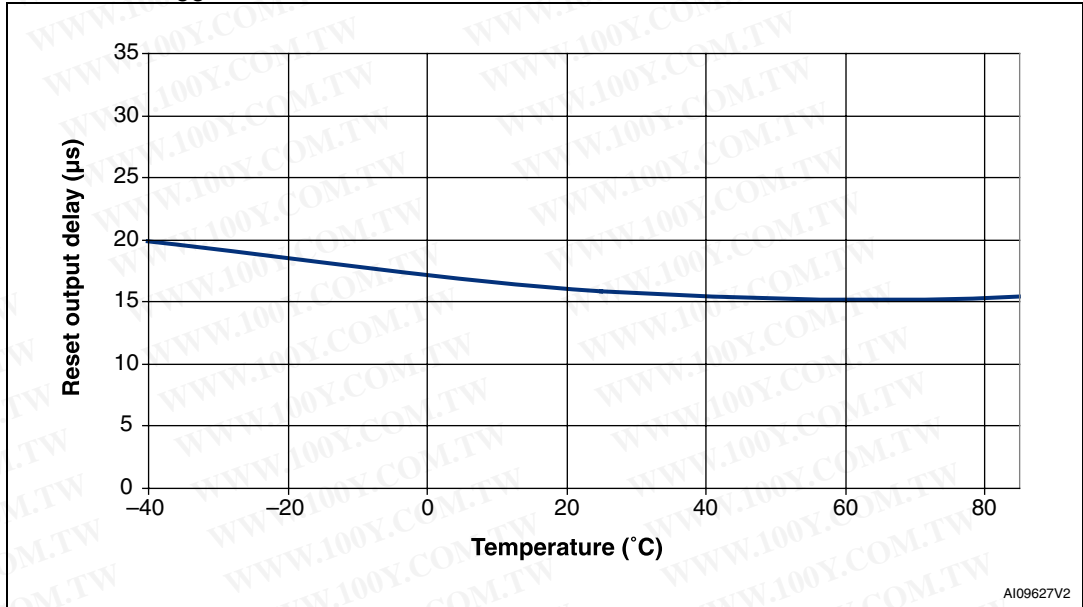


Figure 16. Supply current vs. temperature

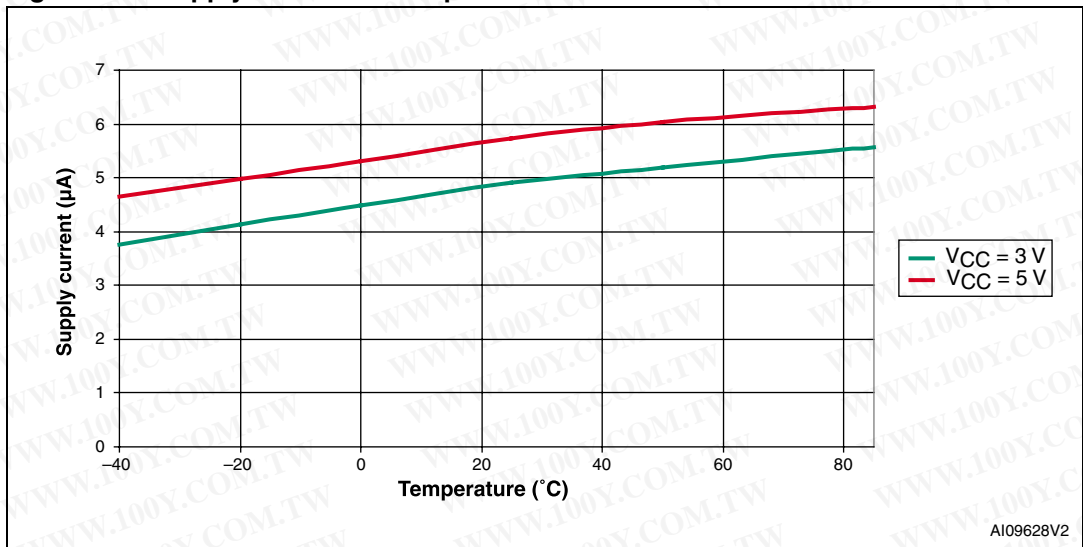


Figure 17.  $\overline{MR}$ -to-reset output delay vs. temperature

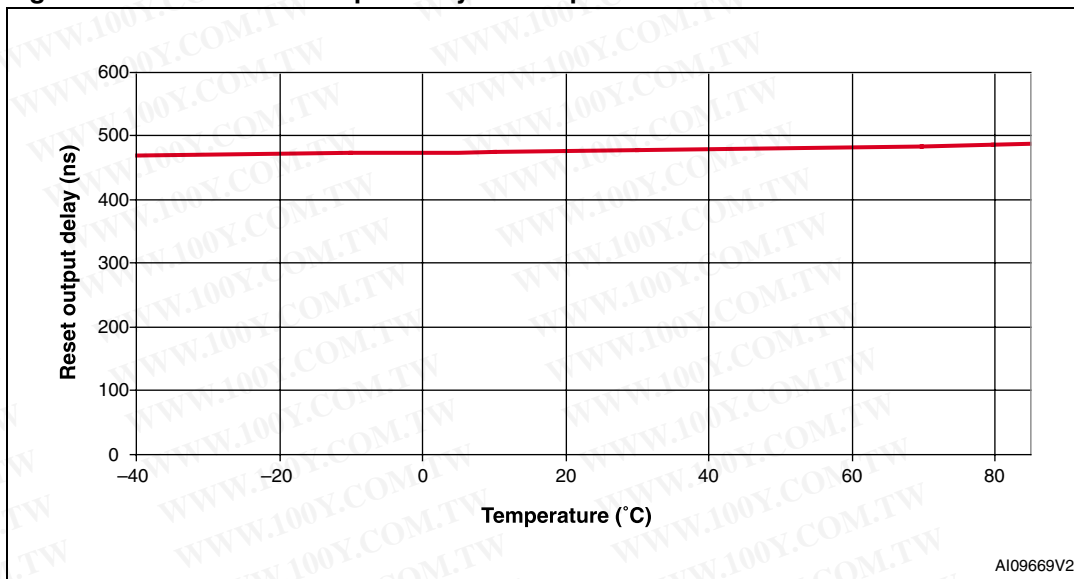


Figure 18. Normalized power-up  $t_{rec}$  vs. temperature

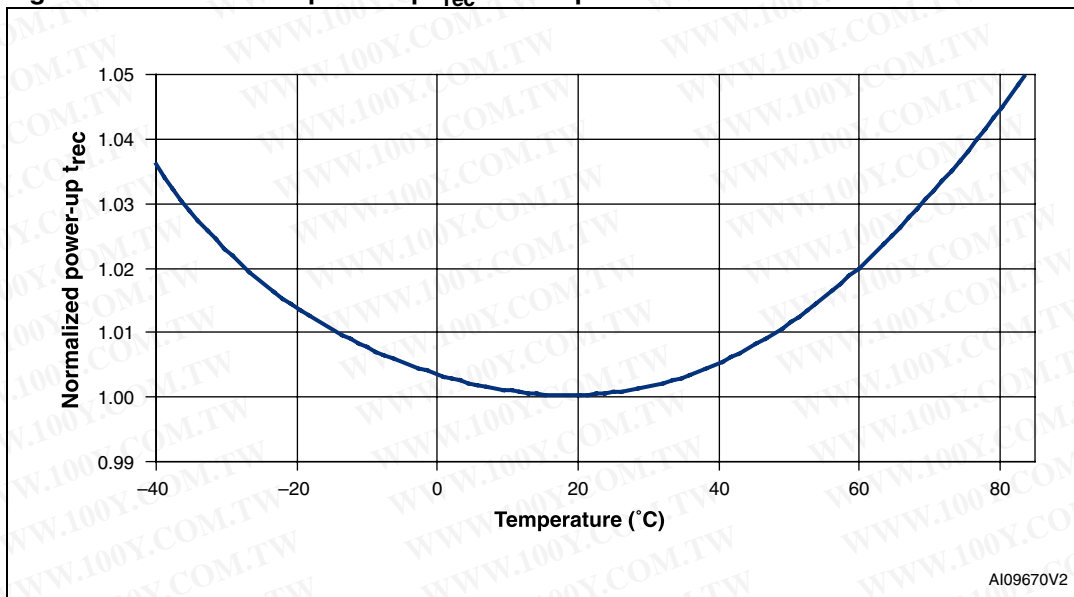


Figure 19. Normalized reset threshold voltage vs. temperature

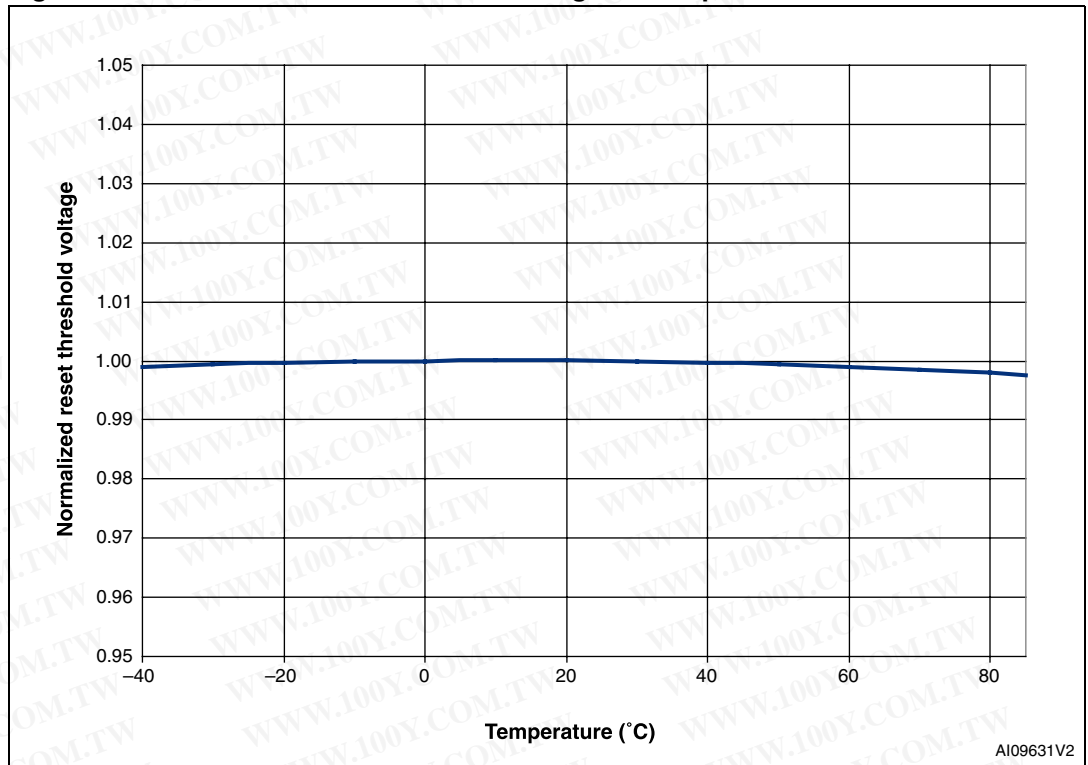


Figure 20. Normalized power-up watchdog timeout period vs. temperature

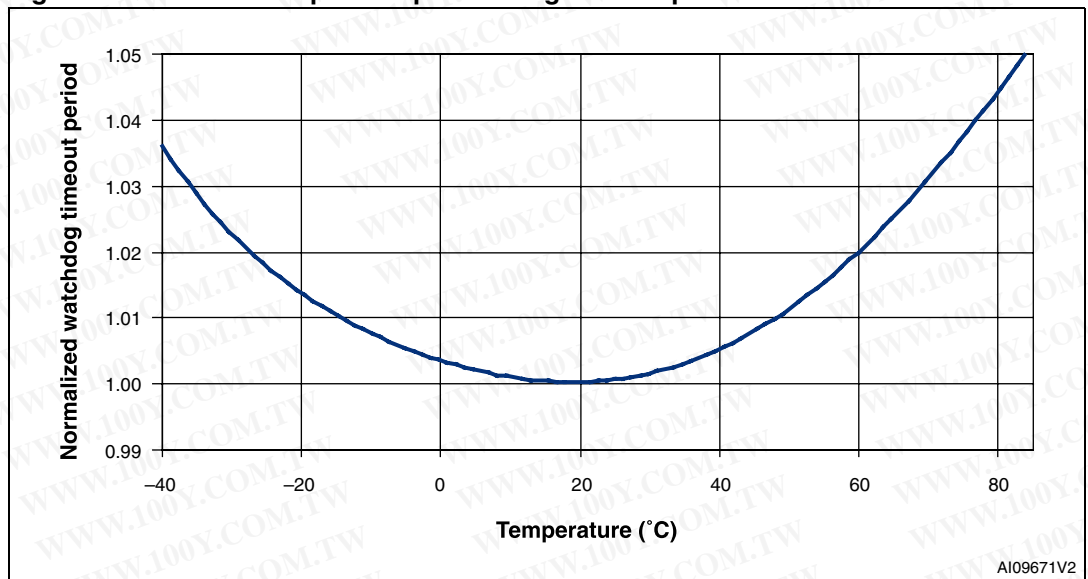


Figure 21. Voltage output low vs.  $I_{SINK}$

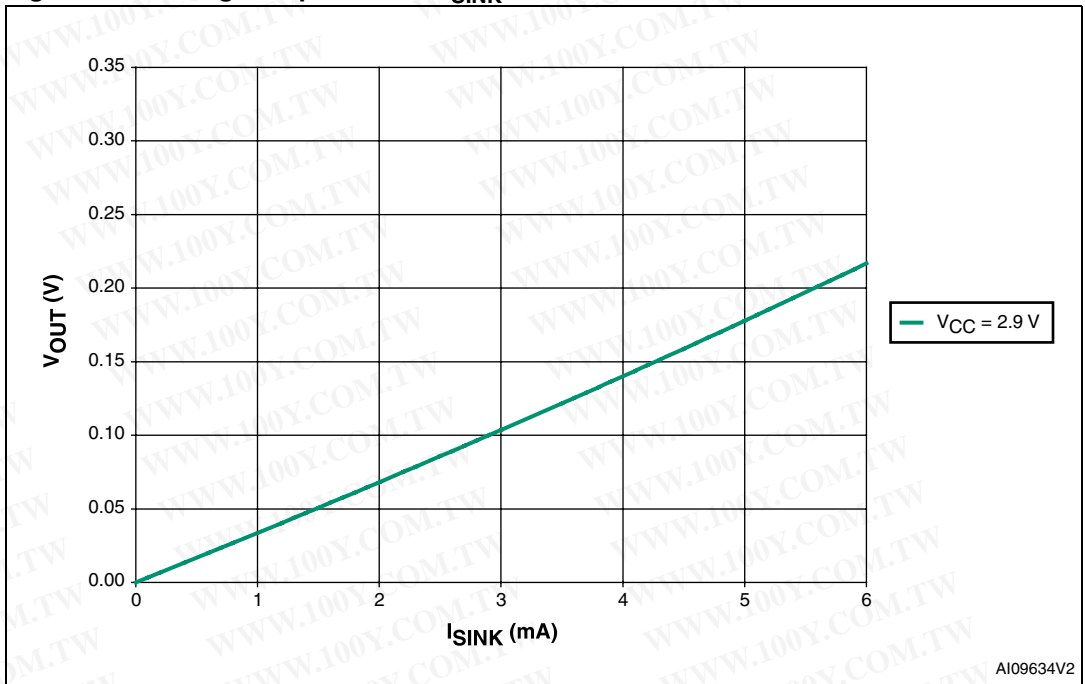


Figure 22. Voltage output high vs.  $I_{SOURCE}$

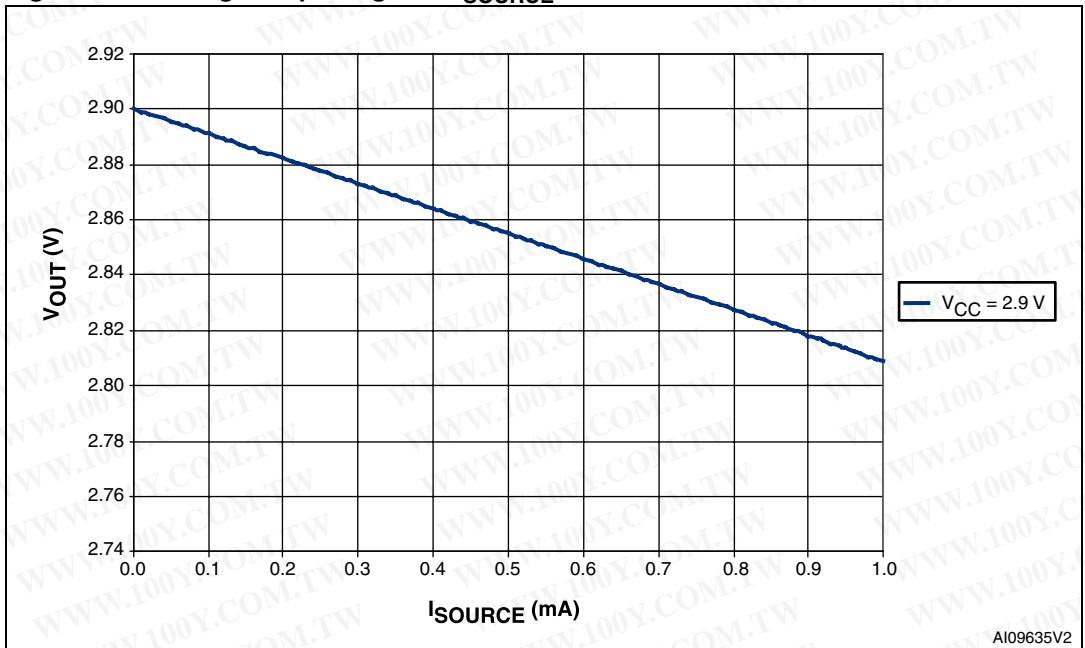
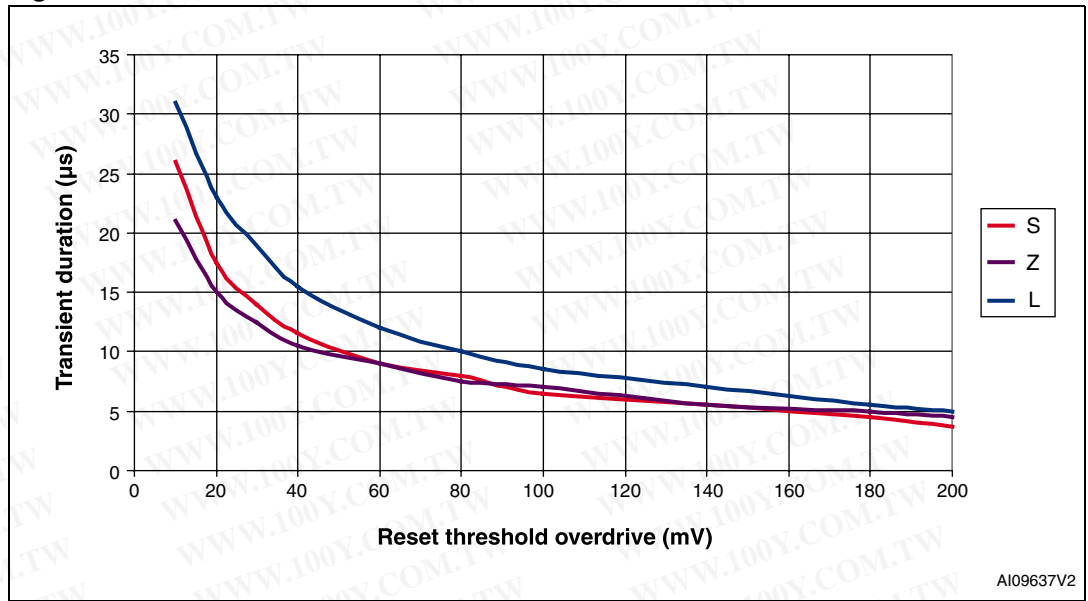


Figure 23. Maximum transient duration vs. reset threshold overdrive



## 4 Maximum ratings

Stressing the device above the rating listed in [Table 4: Absolute maximum ratings](#) may cause permanent damage to the device. These are stress ratings only and operation of the device at these or any other conditions above those indicated in [Table 5: Operating and AC measurement conditions](#) of this specification is not implied. Exposure to absolute maximum rating conditions for extended periods may affect device reliability. Refer also to the STMicroelectronics™ SURE program and other relevant quality documents.

**Table 4. Absolute maximum ratings**

Symbol	Parameter	Value	Unit
$T_{STG}$	Storage temperature ( $V_{CC}$ off)	-55 to 150	°C
$T_{SLD}^{(1)}$	Lead solder temperature for 10 seconds	260	°C
$V_{IO}$	Input or output voltage	-0.3 to $V_{CC} + 0.3$	V
$V_{CC}$	Supply voltage	-0.3 to 7.0	V
$I_O$	Output current	20	mA
$P_D$	Power dissipation	320	mW

1. Reflow at peak temperature of 260 °C (total thermal budget not to exceed 245 °C for greater than 30 seconds).

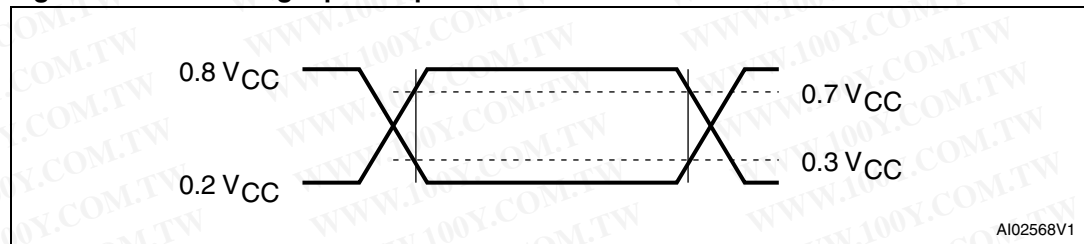
## 5 DC and AC parameters

This section summarizes the operating measurement conditions, and the DC and AC characteristics of the device. The parameters in [Table 6: DC and AC characteristic](#), are derived from tests performed under the measurement conditions summarized in [Table 5: Operating and AC measurement conditions](#). Designers should check that the operating conditions in their circuit match the operating conditions when relying on the quoted parameters.

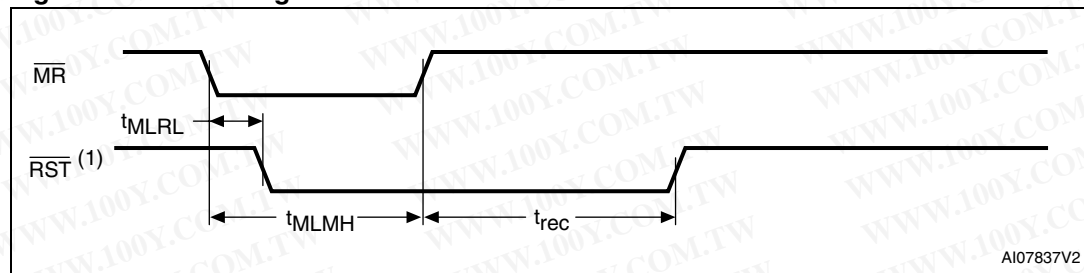
**Table 5. Operating and AC measurement conditions**

Parameter	STM6xxx	Unit
V <sub>CC</sub> supply voltage	1.0 to 5.5	V
Ambient operating temperature (T <sub>A</sub> )	-40 to 85	°C
Input rise and fall times	≤ 5	ns
Input pulse voltages	0.2 to 0.8 V <sub>CC</sub>	V
Input and output timing ref. voltages	0.3 to 0.7 V <sub>CC</sub>	V

**Figure 24. AC testing input/output waveforms**

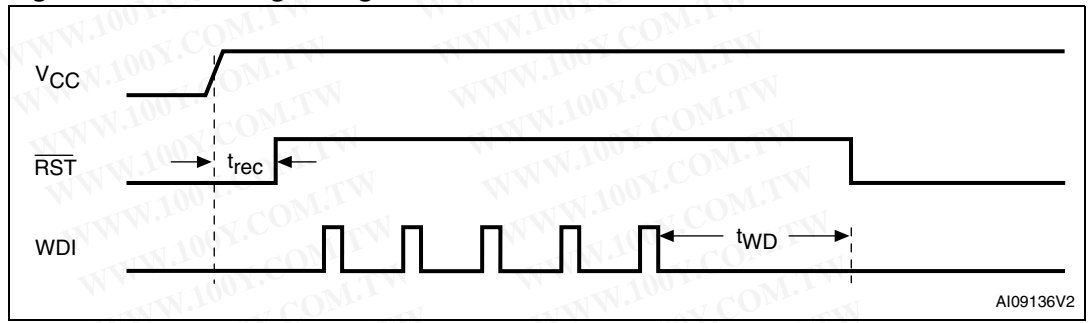


**Figure 25. MR timing waveform**



1. RST for STM6322/6821/6825.

Figure 26. Watchdog timing



## 6 Package mechanical data

Table 6. DC and AC characteristic

Symbol	Alternative	Description	Test condition <sup>(1)</sup>	Min.	Typ.	Max.	Unit
V <sub>CC</sub>		Operating voltage		1.2 <sup>(2)</sup>		5.5	V
I <sub>CC</sub>		V <sub>CC</sub> supply current (MR and WDI unconnected)	T/S/R/Z/Y (V <sub>CC</sub> < 3.6 V)		4	12	μA
			L/M (V <sub>CC</sub> < 5.5 V)		6	17	μA
		V <sub>CC</sub> supply current (MR unconnected; STM6322/6825)	T/S/R/Z/Y (V <sub>CC</sub> < 3.6 V)		3	8	μA
			L/M (V <sub>CC</sub> < 5.5 V)		3	12	μA
I <sub>LI</sub>		Input leakage current	0 V = V <sub>IN</sub> = V <sub>CC</sub>	-1		+1	μA
		Input leakage current (WDI) <sup>(3)</sup>	WDI = V <sub>CC</sub> , time average		120	160	μA
			WDI = GND, time average	-20	-15		μA
I <sub>LO</sub>		Open drain reset output leakage current	V <sub>CC</sub> > V <sub>RST</sub> , Reset not asserted	-1		+1	μA
V <sub>IH</sub>		Input high voltage (MR)	V <sub>RST</sub> > 4.0 V	2.0			V
			V <sub>RST</sub> < 4.0 V	0.7 V <sub>CC</sub>			V
V <sub>IH</sub>		Input high voltage (WDI) <sup>(4)</sup>	V <sub>RST</sub> (max.) < V <sub>CC</sub> < 5.5 V	0.7 V <sub>CC</sub>			V
V <sub>IL</sub>		Input low voltage (MR)	V <sub>RST</sub> > 4.0 V			0.8	V
			V <sub>RST</sub> < 4.0 V			0.3 V <sub>CC</sub>	V
V <sub>IL</sub>		Input low voltage (WDI) <sup>(4)</sup>	V <sub>RST</sub> (max.) < V <sub>CC</sub> < 5.5 V			0.3 V <sub>CC</sub>	V
V <sub>OL</sub>		Output low voltage (RST; push-pull or open drain)	V <sub>CC</sub> ≥ 1.0 V, I <sub>SINK</sub> = 50 μA, Reset asserted			0.3	V
			V <sub>CC</sub> ≥ 1.2 V, I <sub>SINK</sub> = 100 μA, Reset asserted			0.3	V
			V <sub>CC</sub> ≥ 2.7 V, I <sub>SINK</sub> = 1.2 mA, Reset asserted			0.3	V
			V <sub>CC</sub> ≥ 4.5 V, I <sub>SINK</sub> = 3.2 mA, Reset asserted			0.4	V
		Output low voltage (RST; push-pull only)	V <sub>CC</sub> ≥ 2.7 V, I <sub>SINK</sub> = 1.2 mA, Reset not asserted			0.3	V
			V <sub>CC</sub> ≥ 4.5 V, I <sub>SINK</sub> = 3.2 mA, Reset not asserted			0.4	V

Table 6. DC and AC characteristic (continued)

Symbol	Alternative	Description	Test condition <sup>(1)</sup>	Min.	Typ.	Max.	Unit	
V <sub>OH</sub>		Output high voltage ( $\overline{\text{RST}}$ )	V <sub>CC</sub> ≥ 2.7 V, I <sub>SOURCE</sub> = 500 μA, Reset not asserted	0.8 V <sub>CC</sub>			V	
			V <sub>CC</sub> ≥ 4.5 V, I <sub>SOURCE</sub> = 800 μA, Reset not asserted	0.8 V <sub>CC</sub>			V	
		Output high voltage (RST)	V <sub>CC</sub> ≥ 1.0 V, I <sub>SOURCE</sub> = 1 μA, Reset asserted (0 °C to 85 °C)	0.8 V <sub>CC</sub>			V	
			V <sub>CC</sub> ≥ 1.5 V, I <sub>SOURCE</sub> = 100 μA, Reset asserted	0.8 V <sub>CC</sub>			V	
			V <sub>CC</sub> ≥ 2.55 V, I <sub>SOURCE</sub> = 500 μA, Reset asserted	0.8 V <sub>CC</sub>			V	
			V <sub>CC</sub> ≥ 4.25 V, I <sub>SOURCE</sub> = 800 μA, Reset asserted	0.8 V <sub>CC</sub>			V	
	<b>Reset thresholds</b>							
	V <sub>RST</sub> <sup>(5)</sup>		Reset threshold	STM6xxxL	25 °C	4.561	4.630	4.699
-40 to 85 °C					4.514		4.746	V
STM6xxxM				25 °C	4.314	4.390	4.446	V
				-40 to 85 °C	4.270		4.490	V
STM6xxxT				25 °C	3.040	3.080	3.110	V
				-40 to 85 °C	3.000		3.150	V
STM6xxxS				25 °C	2.890	2.930	2.960	V
				-40 to 85 °C	2.857		3.000	V
STM6xxxR				25 °C	2.590	2.630	2.660	V
				-40 to 85 °C	2.564		2.696	V
STM6xxxZ				25 °C	2.266	2.300	2.335	V
				-40 to 85 °C	2.243		2.358	V
STM6xxxY				25 °C	1.970	2.000	2.030	V
				-40 to 85 °C	1.950		2.050	V
		Reset threshold hysteresis	L/M versions		10		mV	
			T/S/R/Z/Y versions		5		mV	
		V <sub>CC</sub> to $\overline{\text{RST}}$ delay (V <sub>RST</sub> - V <sub>CC</sub> = 100 mV, V <sub>CC</sub> falling at 1 mV/μs)			20		μs	
t <sub>rec</sub> <sup>(6)</sup>		Reset pulse width	A	1	1.4	2	ms	
			Blank	140	200	280	ms	
			J	240	360	480	ms	

Table 6. DC and AC characteristic (continued)

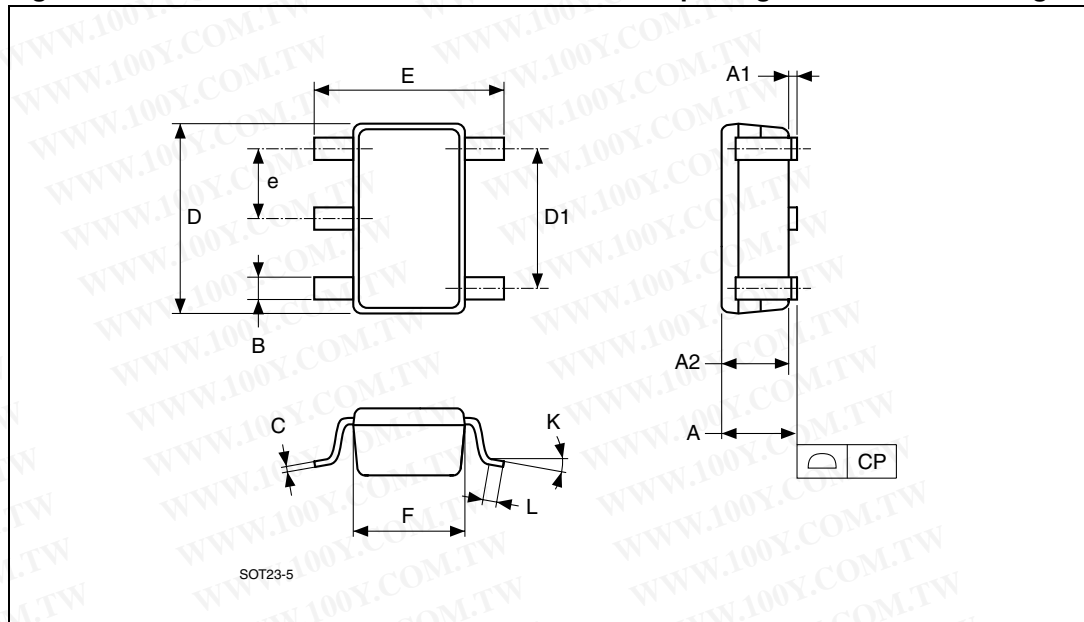
Symbol	Alternative	Description	Test condition <sup>(1)</sup>	Min.	Typ.	Max.	Unit
		Reset threshold temperature coefficient			40		ppm/C
<b>Push-button reset input</b>							
t <sub>MLMH</sub>	t <sub>MR</sub>	$\overline{MR}$ pulse width		1			μs
t <sub>MLRL</sub>	t <sub>MRD</sub>	$\overline{MR}$ to RST output delay			500		ns
		$\overline{MR}$ glitch immunity			100		ns
		$\overline{MR}$ pull-up resistor		35	52	75	kΩ
<b>Watchdog timer</b>							
t <sub>WD</sub> <sup>(6)</sup>		Watchdog timeout period		1.12	1.60	2.24	s
		WDI pulse width <sup>(7)</sup>	V <sub>CC</sub> ≥ 3.0 V	50			ns

- Valid for ambient operating temperature: T<sub>A</sub> = -40 to 85 °C; V<sub>CC</sub> = 4.5 to 5.5 V for “L/M” versions; V<sub>CC</sub> = 2.7 to 3.6 V for “T/S/R” versions; and V<sub>CC</sub> = 1.2 to 2.75 V for “Z/Y” version (except where noted).
- V<sub>CC</sub> (min.) = 1.0 V for T<sub>A</sub> = 0 to +85 °C.
- WDI input is designed to be driven by a three-state output device. To float WDI, the “high-impedance mode” of the output device must have a maximum leakage current of 10 μA and a maximum output capacitance of 200 pF. The output device must also be able to source and sink at least 200 μA when active.
- WDI is internally serviced within the watchdog period if WDI is left unconnected.
- The leakage current measured on the RST pin is tested with the reset asserted (output high impedance).
- Other t<sub>rec</sub> and watchdog timings are offered. Minimum order quantities may apply. Contact local sales office for availability.
- For V<sub>CC</sub> < 3.0 V, t<sub>WD</sub>(min.) = 100 ns.

## 7 Package mechanical data

In order to meet environmental requirements, ST offers these devices in different grades of ECOPACK® packages, depending on their level of environmental compliance. ECOPACK specifications, grade definitions and product status are available at: [www.st.com](http://www.st.com). ECOPACK is an ST trademark.

Figure 27. SOT23-5 – 5-lead small outline transistor package mechanical drawing



1. Drawing is not to scale.

Table 7. SOT23-5 – 5-lead small outline transistor package mechanical data

Symbol	Dimensions					
	mm			inches		
	Typ.	Min.	Max.	Typ.	Min.	Max.
A	1.20	0.90	1.45	0.047	0.035	0.057
A1			0.15			0.006
A2	1.05	0.90	1.30	0.041	0.035	0.051
B	0.40	0.35	0.50	0.016	0.014	0.020
C	0.15	0.09	0.20	0.006	0.004	0.008
D	2.90	2.80	3.00	0.114	0.110	0.118
D1	1.90			0.075		
E	2.80	2.60	3.00	0.110	0.102	0.118
e	0.95			0.037		
F	1.60	1.50	1.75	0.063	0.059	0.069
K		0°	10°		0°	10°
L	0.35	0.10	0.60	0.014	0.004	0.024

Figure 28. Carrier tape for SOT23-5 package

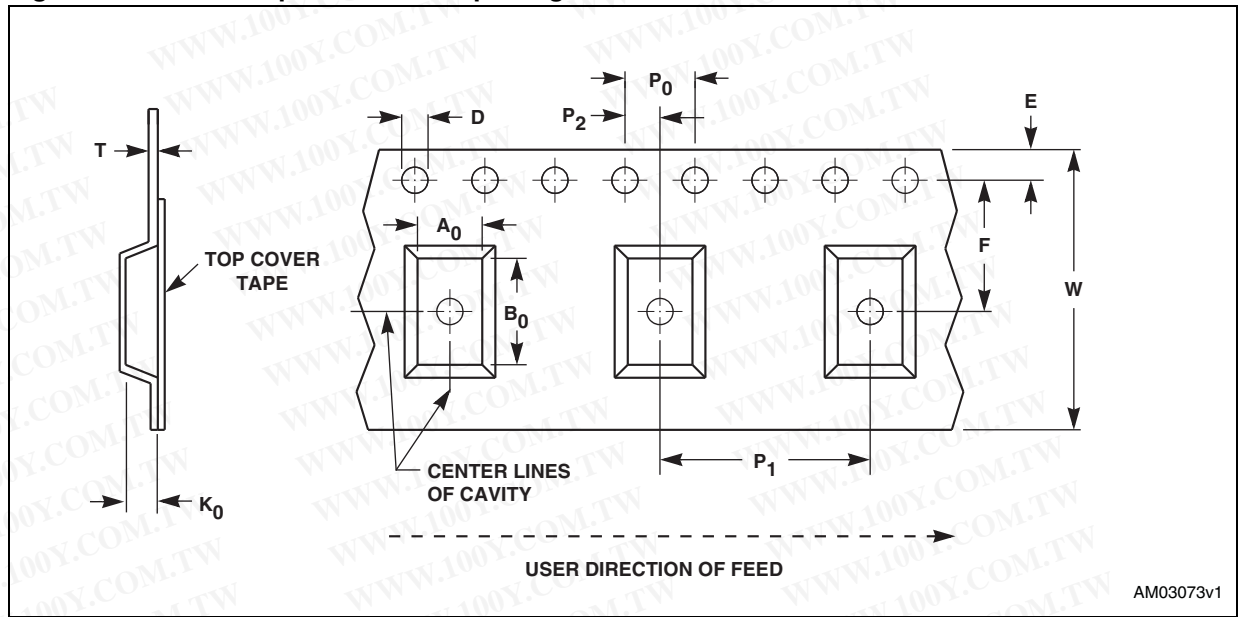


Table 8. Carrier tape dimensions for SOT23-5 package

Package	W	D	E	P <sub>0</sub>	P <sub>2</sub>	F	A <sub>0</sub>	B <sub>0</sub>	K <sub>0</sub>	P <sub>1</sub>	T	Unit	Bulk qty.
SOT23-5	8.00 +0.30 -0.10	1.50 +0.10/ -0.00	1.75 ±0.10	4.00 ±0.10	2.00 ±0.10	3.50 ±0.05	3.23 ±0.10	3.17 ±0.10	1.37 ±0.10	4.00 ±0.10	0.254 ±0.013	mm	3000

# 8 Part numbering

**Table 9. Ordering information scheme**

Example:	STM6xxx	L	WY	6	E
<b>Device type</b>					
STM6xxx					
<b>Reset threshold voltage</b>					
L: $V_{RST} = 4.514$ to $4.746$ V					
M: $V_{RST} = 4.270$ to $4.490$ V					
T: $V_{RST} = 3.000$ to $3.150$ V					
S: $V_{RST} = 2.850$ to $3.000$ V					
R: $V_{RST} = 2.564$ to $2.696$ V					
Z: $V_{RST} = 2.243$ to $2.358$ V					
Y: $V_{RST} = 1.950$ to $2.050$ V					
<b>Reset pulse width<sup>(1)</sup></b>					
A: $t_{rec} = 1$ to $2$ ms					
Blank: $t_{rec} = 140$ to $280$ ms					
J: $t_{rec} = 240$ to $480$ ms					
<b>Package</b>					
WY = SOT23-5					
<b>Temperature range</b>					
6 = $-40$ to $85$ °C					
<b>Shipping method</b>					
E = ECOPACK® package, tubes					
F = ECOPACK® package, tape and reel					

1. Contact local sales office for availability. Other  $t_{rec}$  and watchdog timings are offered. Minimum order quantities may apply.

For other options, or for more information on any aspect of this device, please contact the ST sales office nearest you.



Table 10. Marking description

Part number	Reset threshold (V)	Reset pulse width (ms)	Topside marking <sup>(1)</sup>
STM6321LWY6F	4.630	200	5AU or 5AUx
STM6321MAWY6F	4.390	1.4	5CR or 5CRx
STM6321MWY6F	4.390	200	5AV or 5AVx
STM6321TWY6F	3.080	200	5AW or 5AWx
STM6321SWY6F	2.930	200	5AX or 5AXx
STM6321RWY6F	2.630	200	5AY or 5AYx
STM6322LWY6F	4.630	200	5BA or 5BAx
STM6322MWY6F	4.390	200	5BB or 5BBx
STM6322TWY6F	3.080	200	5BC or 5BCx
STM6322SWY6F	2.930	200	5BD or 5BDx
STM6322RWY6F	2.630	200	5BE or 5BEx
STM6821LWY6F	4.630	200	5BG or 5BGx
STM6821MWY6F	4.390	200	5BH or 5BHx
STM6821TWY6F	3.080	200	5BJ or 5BJx
STM6821SWY6F	2.930	200	5BK or 5BKx
STM6821RWY6F	2.630	200	5BL or 5BLx
STM6822LWY6F	4.630	200	5BN or 5BNx
STM6822MWY6F	4.390	200	5BP or 5BPx
STM6822TWY6F	3.080	200	5BQ or 5BQx
STM6822SWY6F	2.930	200	5BR or 5BRx
STM6822RWY6F	2.630	200	5BS or 5BSx
STM6822ZWY6F	2.300	200	5BT or 5BTx
STM6822YWY6F	2.000	200	5CT or 5CTx
STM6823LWY6F	4.630	200	5BU or 5BUx
STM6823MWY6F	4.390	200	5BV or 5BVx
STM6823JWY6F	3.080	280	5CM or 5CMx
STM6823TWY6F	3.080	200	5BW or 5BWx
STM6823SJWY6F	2.930	280	5CN or 5CNx
STM6823SWY6F	2.930	200	5BX or 5BXx
STM6823RJWY6F	2.630	280	5CP or 5CPx
STM6823RWY6F	2.630	200	5BY or 5BYx
STM6823ZWY6F	2.300	200	5BZ or 5BZx
STM6824LWY6F	4.630	200	5CA or 5CAx
STM6824MWY6F	4.390	200	5CB or 5CBx
STM6824TWY6F	3.080	200	5CC or 5CCx

Table 10. Marking description (continued)

Part number	Reset threshold (V)	Reset pulse width (ms)	Topside marking <sup>(1)</sup>
STM6824SWY6F	2.930	200	5CD or 5CDx
STM6824RWY6F	2.630	200	5CE or 5CEx
STM6825LWY6F	4.630	200	5CG or 5CGx
STM6825MWY6F	4.390	200	5CH or 5CHx
STM6825TWY6F	3.080	200	5CJ or 5CJx
STM6825SWY6F	2.930	200	5CK or 5CKx
STM6825RWY6F	2.630	200	5CL or 5CLx

1. Where "x" = assembly work week (A to Z), such that "A" = WW01-02, "B" = WW03-04, and so forth.

## 9 Revision history

**Table 11. Document revision history**

Date	Revision	Changes
25-Aug-2004	1	First draft
15-Dec-2004	2	Update characteristics ( <a href="#">Figure 15</a> , <a href="#">16</a> , <a href="#">17</a> ; <a href="#">Table 6</a> , and <a href="#">9</a> )
10-Mar-2005	3	Document promoted to Datasheet status
17-Jun-2005	4	Package marking update ( <a href="#">Table 10</a> )
11-Apr-2006	5	Update characteristics, Lead-free text, availability ( <a href="#">Figure 3</a> , <a href="#">4</a> , <a href="#">5</a> , <a href="#">6</a> , <a href="#">7</a> , <a href="#">8</a> , and <a href="#">9</a> ; <a href="#">Table 1</a> , <a href="#">6</a> , <a href="#">9</a> , and <a href="#">10</a> )
11-Aug-2006	6	Update <a href="#">Description</a> , <a href="#">Table 9</a> , and <a href="#">10</a> .
25-May-2007	7	Formatting changes, updated <a href="#">Table 10</a> .
03-Jun-2008	8	Updated cover page; updated reset threshold values in <a href="#">Table 6</a> , <a href="#">9</a> , and <a href="#">10</a> ; addition of text to <a href="#">Section 6</a> ; updated <a href="#">Figure 27</a> and <a href="#">Table 6</a> and <a href="#">7</a> ; minor text changes.
09-Apr-2009	9	Updated <a href="#">Section 1.1.1</a> , <a href="#">Section 6</a> ; added tape and reel specifications <a href="#">Figure 28</a> , <a href="#">Table 8</a> .
06-Jan-2011	10	Document reformatted, Doc ID added, updated <a href="#">Table 10</a> , corrected typo in <a href="#">Features</a> , <a href="#">Section 1.1.4</a> , <a href="#">Section 2.1</a> , <a href="#">Section 2.3</a> , <a href="#">Section 4</a> , <a href="#">Table 4</a> , <a href="#">Table 6</a> , <a href="#">Table 9</a> , <a href="#">Figure 7</a> to <a href="#">Figure 11</a> , <a href="#">Figure 14</a> to <a href="#">Figure 26</a> .
14-Jul-2011	11	Updated <a href="#">Table 10</a> , corrected typo in <a href="#">Table 6</a> , <a href="#">Table 7</a> and <a href="#">Table 8</a> , reformatted <a href="#">Figure 27</a> , updated Disclaimer.
27-Jun-2012	12	Removed note from <a href="#">Features</a> , added cross-references to <a href="#">Section 4</a> and <a href="#">Section 5</a> , minor text corrections throughout document.

勝特力材料 886-3-5753170  
勝特力电子(上海) 86-21-34970699  
勝特力电子(深圳) 86-755-83298787  
[Http://www.100y.com.tw](http://www.100y.com.tw)

**Please Read Carefully:**

Information in this document is provided solely in connection with ST products. STMicroelectronics NV and its subsidiaries ("ST") reserve the right to make changes, corrections, modifications or improvements, to this document, and the products and services described herein at any time, without notice.

All ST products are sold pursuant to ST's terms and conditions of sale.

Purchasers are solely responsible for the choice, selection and use of the ST products and services described herein, and ST assumes no liability whatsoever relating to the choice, selection or use of the ST products and services described herein.

No license, express or implied, by estoppel or otherwise, to any intellectual property rights is granted under this document. If any part of this document refers to any third party products or services it shall not be deemed a license grant by ST for the use of such third party products or services, or any intellectual property contained therein or considered as a warranty covering the use in any manner whatsoever of such third party products or services or any intellectual property contained therein.

**UNLESS OTHERWISE SET FORTH IN ST'S TERMS AND CONDITIONS OF SALE ST DISCLAIMS ANY EXPRESS OR IMPLIED WARRANTY WITH RESPECT TO THE USE AND/OR SALE OF ST PRODUCTS INCLUDING WITHOUT LIMITATION IMPLIED WARRANTIES OF MERCHANTABILITY, FITNESS FOR A PARTICULAR PURPOSE (AND THEIR EQUIVALENTS UNDER THE LAWS OF ANY JURISDICTION), OR INFRINGEMENT OF ANY PATENT, COPYRIGHT OR OTHER INTELLECTUAL PROPERTY RIGHT.**

**UNLESS EXPRESSLY APPROVED IN WRITING BY TWO AUTHORIZED ST REPRESENTATIVES, ST PRODUCTS ARE NOT RECOMMENDED, AUTHORIZED OR WARRANTED FOR USE IN MILITARY, AIR CRAFT, SPACE, LIFE SAVING, OR LIFE SUSTAINING APPLICATIONS, NOR IN PRODUCTS OR SYSTEMS WHERE FAILURE OR MALFUNCTION MAY RESULT IN PERSONAL INJURY, DEATH, OR SEVERE PROPERTY OR ENVIRONMENTAL DAMAGE. ST PRODUCTS WHICH ARE NOT SPECIFIED AS "AUTOMOTIVE GRADE" MAY ONLY BE USED IN AUTOMOTIVE APPLICATIONS AT USER'S OWN RISK.**

Resale of ST products with provisions different from the statements and/or technical features set forth in this document shall immediately void any warranty granted by ST for the ST product or service described herein and shall not create or extend in any manner whatsoever, any liability of ST.

ST and the ST logo are trademarks or registered trademarks of ST in various countries.

Information in this document supersedes and replaces all information previously supplied.

The ST logo is a registered trademark of STMicroelectronics. All other names are the property of their respective owners.

© 2012 STMicroelectronics - All rights reserved

STMicroelectronics group of companies

Australia - Belgium - Brazil - Canada - China - Czech Republic - Finland - France - Germany - Hong Kong - India - Israel - Italy - Japan - Malaysia - Malta - Morocco - Philippines - Singapore - Spain - Sweden - Switzerland - United Kingdom - United States of America

[www.st.com](http://www.st.com)

