



Adjustable and fixed low drop positive voltage regulator

Features

- Low dropout voltage (1 V typ.)
- 2.85 V device performances are suitable for SCSI-2 active termination
- Output current up to 800 mA
- Fixed output voltage of: 1.2 V, 1.8 V, 2.5 V, 3.0 V, 3.3 V, 5.0 V
- Adjustable version availability ($V_{REF} = 1.25$ V)
- Internal current and thermal limit
- Available in ± 1 % (at 25 °C) and 2 % in full temperature range
- Supply voltage rejection: 75 dB (typ.)

Description

The LD1117 is a low drop voltage regulator able to provide up to 800 mA of output current, available even in adjustable version ($V_{REF} = 1.25$ V). Concerning fixed versions, are offered the following output voltages: 1.2 V, 1.8 V, 2.5 V, 2.85 V, 3.0 V, 3.3 V and 5.0 V. The 2.85 V type is ideal for SCSI-2 lines active termination. The device is supplied in: SOT-223, DPAK, SO-8 and TO-220. The SOT-223 and DPAK surface mount packages optimize the thermal characteristics even offering a relevant space saving effect. High efficiency is assured by NPN pass transistor. In fact in this case, unlike than PNP one, the quiescent current flows mostly into the load. Only a very common 10 μ F minimum capacitor is needed for stability.

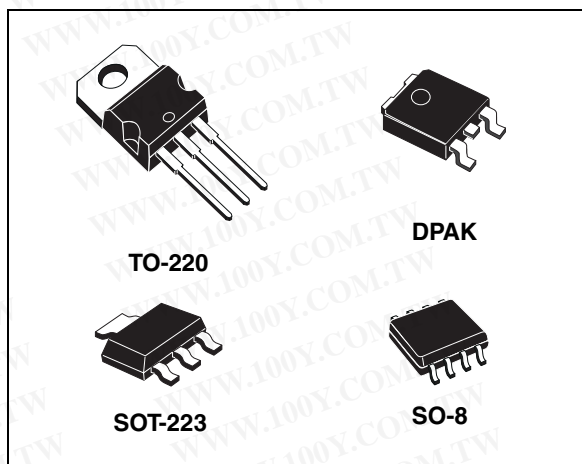

On chip trimming allows the regulator to reach a very tight output voltage tolerance, within ± 1 % at 25 °C. The adjustable LD1117 is pin to pin compatible with the other standard. Adjustable voltage regulators maintaining the better performances in terms of drop and tolerance.

Table 1. Device summary

Part numbers		
LD1117XX12	LD1117XX25C	LD1117XX50C
LD1117XX12C	LD1117XX30	LD1117XX
LD1117XX18	LD1117XX33	LD1117XXC
LD1117XX18C	LD1117XX33C	
LD1117XX25	LD1117XX50	

Contents

1	Diagram	5
2	Pin configuration	6
3	Maximum ratings	7
4	Schematic application	8
5	Electrical characteristics	9
6	Typical application	22
7	LD1117 adjustable: application note	25
8	Package mechanical data	26
9	Order codes	40
10	Revision history	41



List of tables

Table 1.	Device summary	1
Table 2.	Absolute maximum ratings	7
Table 3.	Thermal data	7
Table 4.	Electrical characteristics of LD1117#12	9
Table 5.	Electrical characteristics of LD1117#18	10
Table 6.	Electrical characteristics of LD1117#25	11
Table 7.	Electrical characteristics of LD1117#30	12
Table 8.	Electrical characteristics of LD1117#33	13
Table 9.	Electrical characteristics of LD1117#50	14
Table 10.	Electrical characteristics of LD1117 (adjustable)	15
Table 11.	Electrical characteristics of LD1117#12C	16
Table 12.	Electrical characteristics of LD1117#18C	17
Table 13.	Electrical characteristics of LD1117#25C	18
Table 14.	Electrical characteristics of LD1117#33C	19
Table 15.	Electrical characteristics of LD1117#50C	20
Table 16.	Electrical characteristics of LD1117C (adjustable)	21
Table 17.	TO-220 mechanical data	26
Table 18.	DPAK mechanical data	35
Table 19.	Footprint data	36
Table 20.	Order codes	40
Table 21.	Document revision history	41

List of figures

Figure 1.	Block diagram	5
Figure 2.	Pin connections (top view)	6
Figure 3.	Application circuit (for 1.2 V)	8
Figure 4.	Application circuit (for other fixed output voltages)	8
Figure 5.	Negative supply	22
Figure 6.	Active terminator for SCSI-2 bus	22
Figure 7.	Circuit for increasing output voltage	22
Figure 8.	Voltage regulator with reference	23
Figure 9.	Battery backed-up regulated supply	23
Figure 10.	Post-regulated dual supply	24
Figure 11.	Adjustable output voltage application	25
Figure 12.	Adjustable output voltage application with improved ripple rejection	25
Figure 13.	Drawing dimension TO-220 (type STD-ST Dual Gauge)	27
Figure 14.	Drawing dimension TO-220 (type STD-ST Single Gauge)	28
Figure 15.	Drawing dimension tube for TO-220 Dual Gauge (mm.)	29
Figure 16.	Drawing dimension tube for TO-220 Single Gauge (mm.)	29
Figure 17.	Drawing dimension DPAK (type STD-ST)	32
Figure 18.	Drawing dimension DPAK (type Fujitsu-subcon.)	33
Figure 19.	Drawing dimension DPAK (type IDS-subcon.)	34
Figure 20.	DPAK footprint recommended data	36

1 Diagram

Figure 1. Block diagram

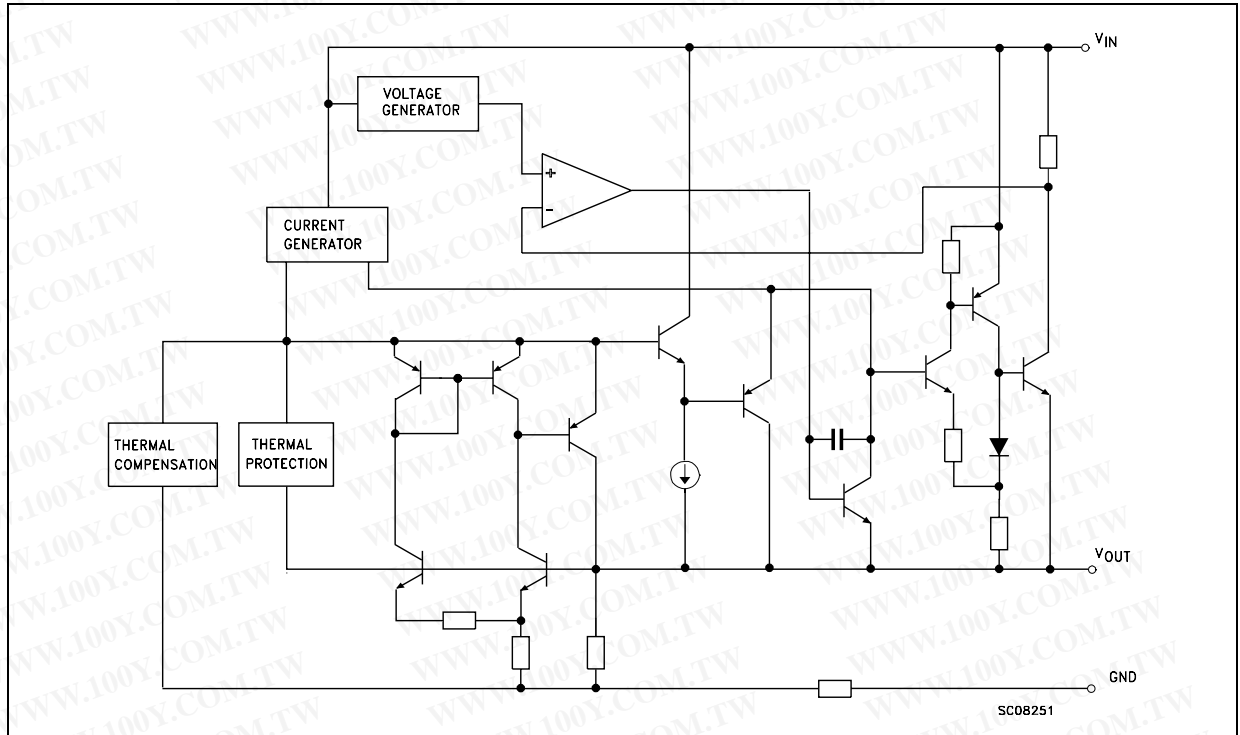

2 Pin configuration

Figure 2. Pin connections (top view)

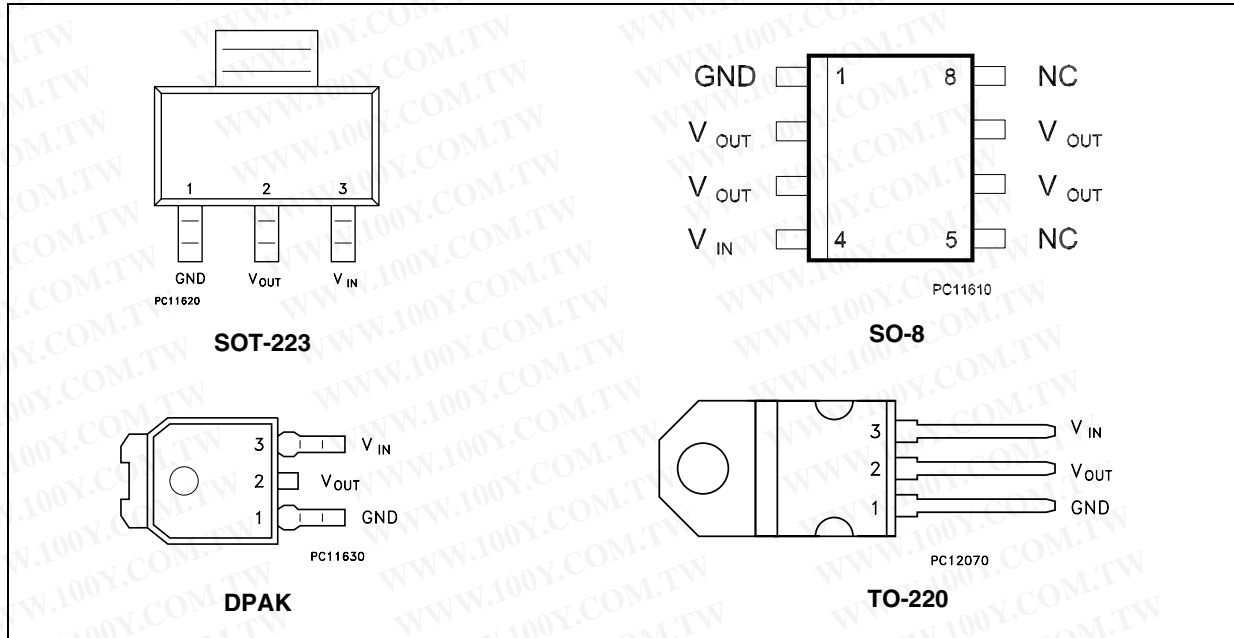

Note: The TAB is connected to the V_{OUT}.

3 Maximum ratings

Table 2. Absolute maximum ratings

Symbol	Parameter	Value	Unit
$V_{IN}^{(1)}$	DC input voltage	15	V
P_{TOT}	Power dissipation	12	W
T_{STG}	Storage temperature range	-40 to +150	°C
T_{OP}	Operating junction temperature range	for C version	-40 to +125
		for standard version	0 to +125

1. Absolute maximum rating of $V_{IN} = 18$ V, when I_{OUT} is lower than 20 mA.

Table 3. Thermal data

Symbol	Parameter	SOT-223	SO-8	DPAK	TO-220	Unit
R_{thJC}	Thermal resistance junction-case	15	20	8	5	°C/W
R_{thJA}	Thermal resistance junction-ambient				50	°C/W

4 Schematic application

Figure 3. Application circuit (for 1.2 V)

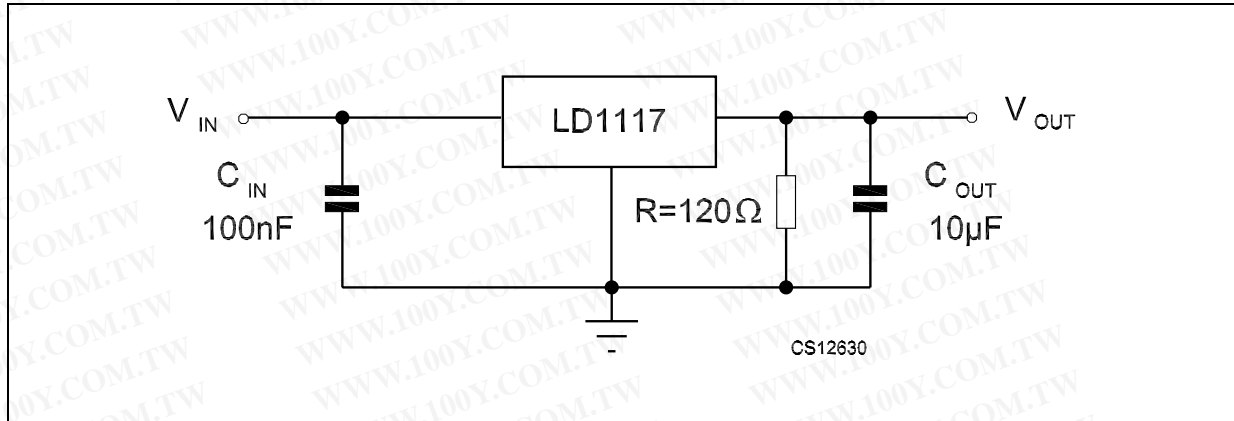
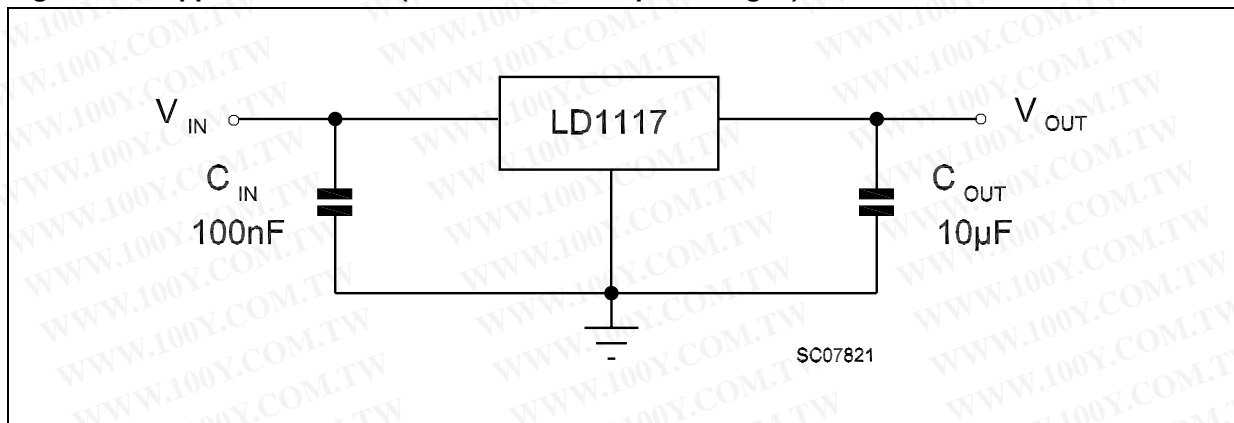

Figure 4. Application circuit (for other fixed output voltages)



5 Electrical characteristics

Refer to the test circuits, $T_J = 0$ to $125\text{ }^\circ\text{C}$, $C_O = 10\text{ }\mu\text{F}$, $R = 120\text{ }\Omega$ between GND and OUT pins, unless otherwise specified.

Table 4. Electrical characteristics of LD1117#12

Symbol	Parameter	Test condition	Min.	Typ.	Max.	Unit
V_O	Output voltage	$V_{in} = 3.2\text{ V}$, $I_O = 10\text{ mA}$, $T_J = 25\text{ }^\circ\text{C}$	1.188	1.20	1.212	V
V_O	Reference voltage	$I_O = 10$ to 800 mA $V_{in} - V_O = 1.4$ to 10 V	1.140	1.20	1.260	V
ΔV_O	Line regulation	$V_{in} - V_O = 1.5$ to 13.75 V , $I_O = 10\text{ mA}$		0.035	0.2	%
ΔV_O	Load regulation	$V_{in} - V_O = 3\text{ V}$, $I_O = 10$ to 800 mA		0.1	0.4	%
ΔV_O	Temperature stability			0.5		%
ΔV_O	Long term stability	1000 hrs, $T_J = 125\text{ }^\circ\text{C}$		0.3		%
V_{in}	Operating input voltage				15	V
I_{adj}	Adjustment pin current	$V_{in} \leq 15\text{ V}$		60	120	μA
ΔI_{adj}	Adjustment pin current change	$V_{in} - V_O = 1.4$ to 10 V $I_O = 10$ to 800 mA		1	5	μA
$I_{O(min)}$	Minimum load current	$V_{in} = 15\text{ V}$		2	5	mA
I_O	Output current	$V_{in} - V_O = 5\text{ V}$, $T_J = 25\text{ }^\circ\text{C}$	800	950	1300	mA
eN	Output noise (% V_O)	$B = 10\text{ Hz}$ to 10 kHz , $T_J = 25\text{ }^\circ\text{C}$		0.003		%
SVR	Supply voltage rejection	$I_O = 40\text{ mA}$, $f = 120\text{ Hz}$, $T_J = 25\text{ }^\circ\text{C}$ $V_{in} - V_O = 3\text{ V}$, $V_{ripple} = 1\text{ V}_{PP}$	60	75		dB
V_d	Dropout voltage	$I_O = 100\text{ mA}$		1	1.1	V
		$I_O = 500\text{ mA}$		1.05	1.15	
		$I_O = 800\text{ mA}$		1.10	1.2	
	Thermal regulation	$T_a = 25\text{ }^\circ\text{C}$, 30 ms Pulse		0.01	0.1	%/W

Refer to the test circuits, $T_J = 0$ to $125\text{ }^\circ\text{C}$, $C_O = 10\text{ }\mu\text{F}$, unless otherwise specified.

Table 5. Electrical characteristics of LD1117#18

Symbol	Parameter	Test condition	Min.	Typ.	Max.	Unit
V_O	Output voltage	$V_{in} = 3.8\text{ V}$, $I_O = 10\text{ mA}$, $T_J = 25\text{ }^\circ\text{C}$	1.78	1.8	1.82	V
V_O	Output voltage	$I_O = 0$ to 800 mA , $V_{in} = 3.3$ to 8 V	1.76		1.84	V
ΔV_O	Line regulation	$V_{in} = 3.3$ to 8 V , $I_O = 0\text{ mA}$		1	6	mV
ΔV_O	Load regulation	$V_{in} = 3.3\text{ V}$, $I_O = 0$ to 800 mA		1	10	mV
ΔV_O	Temperature stability			0.5		%
ΔV_O	Long term stability	1000 hrs, $T_J = 125\text{ }^\circ\text{C}$		0.3		%
V_{in}	Operating input voltage	$I_O = 100\text{ mA}$			15	V
I_d	Quiescent current	$V_{in} \leq 8\text{ V}$		5	10	mA
I_O	Output current	$V_{in} = 6.8\text{ V}$, $T_J = 25\text{ }^\circ\text{C}$	800	950	1300	mA
eN	Output noise voltage	$B = 10\text{ Hz}$ to 10 kHz , $T_J = 25\text{ }^\circ\text{C}$		100		μV
SVR	Supply voltage rejection	$I_O = 40\text{ mA}$, $f = 120\text{ Hz}$, $T_J = 25\text{ }^\circ\text{C}$ $V_{in} = 5.5\text{ V}$, $V_{ripple} = 1\text{ V}_{PP}$	60	75		dB
V_d	Dropout voltage	$I_O = 100\text{ mA}$		1	1.1	V
		$I_O = 500\text{ mA}$		1.05	1.15	
		$I_O = 800\text{ mA}$		1.10	1.2	
	Thermal regulation	$T_a = 25\text{ }^\circ\text{C}$, 30 ms Pulse		0.01	0.1	%/W

Refer to the test circuits, $T_J = 0$ to 125 °C, $C_O = 10$ μ F, unless otherwise specified.

Table 6. Electrical characteristics of LD1117#25

Symbol	Parameter	Test condition	Min.	Typ.	Max.	Unit
V_O	Output voltage	$V_{in} = 4.5$ V, $I_O = 10$ mA, $T_J = 25$ °C	2.475	2.5	2.525	V
V_O	Output voltage	$I_O = 0$ to 800 mA, $V_{in} = 3.9$ to 10 V	2.45		2.55	V
ΔV_O	Line regulation	$V_{in} = 3.9$ to 10 V, $I_O = 0$ mA		1	6	mV
ΔV_O	Load regulation	$V_{in} = 3.9$ V, $I_O = 0$ to 800 mA		1	10	mV
ΔV_O	Temperature stability			0.5		%
ΔV_O	Long term stability	1000 hrs, $T_J = 125$ °C		0.3		%
V_{in}	Operating input voltage	$I_O = 100$ mA			15	V
I_d	Quiescent current	$V_{in} \leq 10$ V		5	10	mA
I_O	Output current	$V_{in} = 7.5$ V, $T_J = 25$ °C	800	950	1300	mA
eN	Output noise voltage	B = 10 Hz to 10 kHz, $T_J = 25$ °C		100		μ V
SVR	Supply voltage rejection	$I_O = 40$ mA, $f = 120$ Hz, $T_J = 25$ °C $V_{in} = 5.5$ V, $V_{ripple} = 1$ V _{PP}	60	75		dB
V_d	Dropout voltage	$I_O = 100$ mA		1	1.1	V
		$I_O = 500$ mA		1.05	1.15	
		$I_O = 800$ mA		1.10	1.2	
	Thermal regulation	$T_a = 25$ °C, 30 ms Pulse		0.01	0.1	%/W

Refer to the test circuits, $T_J = 0$ to $125\text{ }^\circ\text{C}$, $C_O = 10\text{ }\mu\text{F}$, unless otherwise specified.

Table 7. Electrical characteristics of LD1117#30

Symbol	Parameter	Test condition	Min.	Typ.	Max.	Unit
V_O	Output voltage	$V_{in} = 5\text{ V}$, $I_O = 10\text{ mA}$, $T_J = 25\text{ }^\circ\text{C}$	2.97	3	3.03	V
V_O	Output voltage	$I_O = 0$ to 800 mA , $V_{in} = 4.5$ to 10 V	2.94		3.06	V
ΔV_O	Line regulation	$V_{in} = 4.5$ to 12 V , $I_O = 0\text{ mA}$		1	6	mV
ΔV_O	Load regulation	$V_{in} = 4.5\text{ V}$, $I_O = 0$ to 800 mA		1	10	mV
ΔV_O	Temperature stability			0.5		%
ΔV_O	Long term stability	1000 hrs, $T_J = 125\text{ }^\circ\text{C}$		0.3		%
V_{in}	Operating input voltage	$I_O = 100\text{ mA}$			15	V
I_d	Quiescent current	$V_{in} \leq 12\text{ V}$		5	10	mA
I_O	Output current	$V_{in} = 8\text{ V}$, $T_J = 25\text{ }^\circ\text{C}$	800	950	1300	mA
eN	Output noise voltage	$B = 10\text{ Hz}$ to 10 kHz , $T_J = 25\text{ }^\circ\text{C}$		100		μF
SVR	Supply voltage rejection	$I_O = 40\text{ mA}$, $f = 120\text{ Hz}$, $T_J = 25\text{ }^\circ\text{C}$ $V_{in} = 6\text{ V}$, $V_{ripple} = 1\text{ V}_{PP}$	60	75		dB
V_d	Dropout voltage	$I_O = 100\text{ mA}$		1	1.1	V
		$I_O = 500\text{ mA}$		1.05	1.15	
		$I_O = 800\text{ mA}$		1.10	1.2	
	Thermal regulation	$T_a = 25\text{ }^\circ\text{C}$, 30 ms Pulse		0.01	0.1	%/W

Refer to the test circuits, $T_J = 0$ to 125 °C, $C_O = 10$ μ F, unless otherwise specified.

Table 8. Electrical characteristics of LD1117#33

Symbol	Parameter	Test condition	Min.	Typ.	Max.	Unit
V_O	Output voltage	$V_{in} = 5.3$ V, $I_O = 10$ mA, $T_J = 25$ °C	3.267	3.3	3.333	V
V_O	Output voltage	$I_O = 0$ to 800 mA, $V_{in} = 4.75$ to 10 V	3.235		3.365	V
ΔV_O	Line regulation	$V_{in} = 4.75$ to 15 V, $I_O = 0$ mA		1	6	mV
ΔV_O	Load regulation	$V_{in} = 4.75$ V, $I_O = 0$ to 800 mA		1	10	mV
ΔV_O	Temperature stability			0.5		%
ΔV_O	Long term stability	1000 hrs, $T_J = 125$ °C		0.3		%
V_{in}	Operating input voltage	$I_O = 100$ mA			15	V
I_d	Quiescent current	$V_{in} \leq 15$ V		5	10	mA
I_O	Output current	$V_{in} = 8.3$ V, $T_J = 25$ °C	800	950	1300	mA
eN	Output noise voltage	B = 10 Hz to 10 kHz, $T_J = 25$ °C		100		μ V
SVR	Supply voltage rejection	$I_O = 40$ mA, $f = 120$ Hz, $T_J = 25$ °C $V_{in} = 6.3$ V, $V_{ripple} = 1$ V _{PP}	60	75		dB
V_d	Dropout voltage	$I_O = 100$ mA		1	1.1	V
		$I_O = 500$ mA		1.05	1.15	
		$I_O = 800$ mA		1.10	1.2	
	Thermal regulation	$T_a = 25$ °C, 30 ms Pulse		0.01	0.1	%/W

Refer to the test circuits, $T_J = 0$ to $125\text{ }^\circ\text{C}$, $C_O = 10\text{ }\mu\text{F}$, unless otherwise specified.

Table 9. Electrical characteristics of LD1117#50

Symbol	Parameter	Test condition	Min.	Typ.	Max.	Unit
V_O	Output voltage	$V_{in} = 7\text{ V}$, $I_O = 10\text{ mA}$, $T_J = 25\text{ }^\circ\text{C}$	4.95	5	5.05	V
V_O	Output voltage	$I_O = 0$ to 800 mA , $V_{in} = 6.5$ to 15 V	4.9		5.1	V
ΔV_O	Line regulation	$V_{in} = 6.5$ to 15 V , $I_O = 0\text{ mA}$		1	10	mV
ΔV_O	Load regulation	$V_{in} = 6.5\text{ V}$, $I_O = 0$ to 800 mA		1	15	mV
ΔV_O	Temperature stability			0.5		%
ΔV_O	Long term stability	1000 hrs, $T_J = 125\text{ }^\circ\text{C}$		0.3		%
V_{in}	Operating input voltage	$I_O = 100\text{ mA}$			15	V
I_d	Quiescent current	$V_{in} \leq 15\text{ V}$		5	10	mA
I_O	Output current	$V_{in} = 10\text{ V}$, $T_J = 25\text{ }^\circ\text{C}$	800	950	1300	mA
eN	Output noise voltage	$B = 10\text{ Hz}$ to 10 kHz , $T_J = 25\text{ }^\circ\text{C}$		100		μV
SVR	Supply voltage rejection	$I_O = 40\text{ mA}$, $f = 120\text{ Hz}$, $T_J = 25\text{ }^\circ\text{C}$ $V_{in} = 8\text{ V}$, $V_{ripple} = 1\text{ V}_{PP}$	60	75		dB
V_d	Dropout voltage	$I_O = 100\text{ mA}$		1	1.1	V
		$I_O = 500\text{ mA}$		1.05	1.15	
		$I_O = 800\text{ mA}$		1.10	1.2	
	Thermal regulation	$T_a = 25\text{ }^\circ\text{C}$, 30 ms Pulse		0.01	0.1	%/W

Refer to the test circuits, $T_J = 0$ to $125\text{ }^\circ\text{C}$, $C_O = 10\text{ }\mu\text{F}$, unless otherwise specified.

Table 10. Electrical characteristics of LD1117 (adjustable)

Symbol	Parameter	Test condition	Min.	Typ.	Max.	Unit
V_{ref}	Reference voltage	$V_{in} - V_O = 2\text{ V}$, $I_O = 10\text{ mA}$, $T_J = 25\text{ }^\circ\text{C}$	1.238	1.25	1.262	V
V_{ref}	Reference voltage	$I_O = 10$ to 800 mA , $V_{in} - V_O = 1.4$ to 10 V	1.225		1.275	V
ΔV_O	Line regulation	$V_{in} - V_O = 1.5$ to 13.75 V , $I_O = 10\text{ mA}$		0.035	0.2	%
ΔV_O	Load regulation	$V_{in} - V_O = 3\text{ V}$, $I_O = 10$ to 800 mA		0.1	0.4	%
ΔV_O	Temperature stability			0.5		%
ΔV_O	Long term stability	1000 hrs, $T_J = 125\text{ }^\circ\text{C}$		0.3		%
V_{in}	Operating input voltage				15	V
I_{adj}	Adjustment pin current	$V_{in} \leq 15\text{ V}$		60	120	μA
ΔI_{adj}	Adjustment pin current change	$V_{in} - V_O = 1.4$ to 10 V , $I_O = 10$ to 800 mA		1	5	μA
$I_{O(min)}$	Minimum load current	$V_{in} = 15\text{ V}$		2	5	mA
I_O	Output current	$V_{in} - V_O = 5\text{ V}$, $T_J = 25\text{ }^\circ\text{C}$	800	950	1300	mA
eN	Output noise (% V_O)	$B = 10\text{ Hz}$ to 10 kHz , $T_J = 25\text{ }^\circ\text{C}$		0.003		%
SVR	Supply voltage rejection	$I_O = 40\text{ mA}$, $f = 120\text{ Hz}$, $T_J = 25\text{ }^\circ\text{C}$ $V_{in} - V_O = 3\text{ V}$, $V_{ripple} = 1\text{ V}_{PP}$	60	75		dB
V_d	Dropout voltage	$I_O = 100\text{ mA}$		1	1.1	V
		$I_O = 500\text{ mA}$		1.05	1.15	
		$I_O = 800\text{ mA}$		1.10	1.2	
	Thermal regulation	$T_a = 25\text{ }^\circ\text{C}$, 30 ms Pulse		0.01	0.1	%/W

Refer to the test circuits, $T_J = -40$ to $125\text{ }^\circ\text{C}$, $C_O = 10\text{ }\mu\text{F}$, $R = 120\text{ }\Omega$ between GND and OUT pins, unless otherwise specified.

Table 11. Electrical characteristics of LD1117#12C

Symbol	Parameter	Test condition	Min.	Typ.	Max.	Unit
V_{ref}	Reference voltage	$V_{in} - V_O = 2\text{ V}$, $I_O = 10\text{ mA}$, $T_J = 25\text{ }^\circ\text{C}$	1.176	1.20	1.224	V
V_{ref}	Reference voltage	$I_O = 10$ to 800 mA , $V_{in} - V_O = 1.4$ to 10 V	1.120	1.20	1.280	V
ΔV_O	Line regulation	$V_{in} - V_O = 1.5$ to 13.75 V , $I_O = 10\text{ mA}$			1	%
ΔV_O	Load regulation	$V_{in} - V_O = 3\text{ V}$, $I_O = 10$ to 800 mA			1	%
ΔV_O	Temperature stability			0.5		%
ΔV_O	Long term stability	1000 hrs, $T_J = 125\text{ }^\circ\text{C}$		0.3		%
V_{in}	Operating input voltage				15	V
I_{adj}	Adjustment pin current	$V_{in} \leq 15\text{ V}$		60	120	μA
ΔI_{adj}	Adjustment pin current change	$V_{in} - V_O = 1.4$ to 10 V $I_O = 10$ to 800 mA		1	5	μA
$I_{O(min)}$	Minimum load current	$V_{in} = 15\text{ V}$		2	5	mA
I_O	Output current	$V_{in} - V_O = 5\text{ V}$, $T_J = 25\text{ }^\circ\text{C}$	800	950	1300	mA
eN	Output noise (% V_O)	$B = 10\text{ Hz}$ to 10 kHz , $T_J = 25\text{ }^\circ\text{C}$		0.003		%
SVR	Supply voltage rejection	$I_O = 40\text{ mA}$, $f = 120\text{ Hz}$, $T_J = 25\text{ }^\circ\text{C}$ $V_{in} - V_O = 3\text{ V}$, $V_{ripple} = 1\text{ V}_{PP}$	60	75		dB
V_d	Dropout voltage	$I_O = 100\text{ mA}$, $T_J = 0$ to $125\text{ }^\circ\text{C}$		1	1.1	V
		$I_O = 500\text{ mA}$, $T_J = 0$ to $125\text{ }^\circ\text{C}$		1.05	1.2	
		$I_O = 800\text{ mA}$, $T_J = 0$ to $125\text{ }^\circ\text{C}$		1.10	1.3	
	Thermal regulation	$T_a = 25\text{ }^\circ\text{C}$, 30 ms Pulse		0.01	0.1	%/W

Refer to the test circuits, $T_J = -40$ to 125 °C, $C_O = 10$ μ F, unless otherwise specified.

Table 12. Electrical characteristics of LD1117#18C

Symbol	Parameter	Test condition	Min.	Typ.	Max.	Unit
V_O	Output voltage	$V_{in} = 3.8$ V, $I_O = 10$ mA, $T_J = 25$ °C	1.76	1.8	1.84	V
V_O	Output voltage	$I_O = 0$ to 800 mA, $V_{in} = 3.9$ to 10 V	1.73		1.87	V
ΔV_O	Line regulation	$V_{in} = 3.3$ to 8 V, $I_O = 0$ mA		1	30	mV
ΔV_O	Load regulation	$V_{in} = 3.3$ V, $I_O = 0$ to 800 mA		1	30	mV
ΔV_O	Temperature stability			0.5		%
ΔV_O	Long term stability	1000 hrs, $T_J = 125$ °C		0.3		%
V_{in}	Operating input voltage	$I_O = 100$ mA			15	V
I_d	Quiescent current	$V_{in} \leq 8$ V		5	10	mA
I_O	Output current	$V_{in} = 6.8$ V $T_J = 25$ °C	800	950	1300	mA
eN	Output noise voltage	B = 10 Hz to 10 kHz, $T_J = 25$ °C		100		μ V
SVR	Supply voltage rejection	$I_O = 40$ mA, $f = 120$ Hz, $T_J = 25$ °C $V_{in} = 5.5$ V, $V_{ripple} = 1$ V _{PP}	60	75		dB
V_d	Dropout voltage	$I_O = 100$ mA, $T_J = 0$ to 125 °C		1	1.1	V
		$I_O = 500$ mA, $T_J = 0$ to 125 °C		1.05	1.15	
		$I_O = 800$ mA, $T_J = 0$ to 125 °C		1.10	1.2	
V_d	Dropout voltage	$I_O = 100$ mA			1.1	V
		$I_O = 500$ mA			1.2	
		$I_O = 800$ mA			1.3	
	Thermal regulation	$T_a = 25$ °C, 30 ms Pulse		0.01	0.1	%/W

Refer to the test circuits, $T_J = -40$ to $125\text{ }^\circ\text{C}$, $C_O = 10\text{ }\mu\text{F}$, unless otherwise specified.

Table 13. Electrical characteristics of LD1117#25C

Symbol	Parameter	Test condition	Min.	Typ.	Max.	Unit
V_O	Output voltage	$V_{in} = 4.5\text{ V}$, $I_O = 10\text{ mA}$, $T_J = 25\text{ }^\circ\text{C}$	2.45	2.5	2.55	V
V_O	Output voltage	$I_O = 0$ to 800 mA , $V_{in} = 3.9$ to 10 V	2.4		2.6	V
ΔV_O	Line regulation	$V_{in} = 3.9$ to 10 V , $I_O = 0\text{ mA}$		1	30	mV
ΔV_O	Load regulation	$V_{in} = 3.9\text{ V}$, $I_O = 0$ to 800 mA		1	30	mV
ΔV_O	Temperature stability			0.5		%
ΔV_O	Long term stability	1000 hrs, $T_J = 125\text{ }^\circ\text{C}$		0.3		%
V_{in}	Operating input voltage	$I_O = 100\text{ mA}$			15	V
I_d	Quiescent current	$V_{in} \leq 10\text{ V}$		5	10	mA
I_O	Output current	$V_{in} = 7.5\text{ V}$, $T_J = 25\text{ }^\circ\text{C}$	800	950	1300	mA
eN	Output noise voltage	$B = 10\text{ Hz}$ to 10 kHz , $T_J = 25\text{ }^\circ\text{C}$		100		μV
SVR	Supply voltage rejection	$I_O = 40\text{ mA}$, $f = 120\text{ Hz}$, $T_J = 25\text{ }^\circ\text{C}$ $V_{in} = 5.5\text{ V}$, $V_{ripple} = 1\text{ V}_{PP}$	60	75		dB
V_d	Dropout voltage	$I_O = 100\text{ mA}$, $T_J = 0$ to $125\text{ }^\circ\text{C}$		1	1.1	V
		$I_O = 500\text{ mA}$, $T_J = 0$ to $125\text{ }^\circ\text{C}$		1.05	1.15	
		$I_O = 800\text{ mA}$, $T_J = 0$ to $125\text{ }^\circ\text{C}$		1.10	1.2	
V_d	Dropout voltage	$I_O = 100\text{ mA}$			1.1	V
		$I_O = 500\text{ mA}$			1.2	
		$I_O = 800\text{ mA}$			1.3	
	Thermal regulation	$T_a = 25\text{ }^\circ\text{C}$, 30 ms Pulse		0.01	0.1	%/W

Refer to the test circuits, $T_J = -40$ to 125 °C, $C_O = 10$ μ F, unless otherwise specified.

Table 14. Electrical characteristics of LD1117#33C

Symbol	Parameter	Test condition	Min.	Typ.	Max.	Unit
V_O	Output voltage	$V_{in} = 5.3$ V, $I_O = 10$ mA, $T_J = 25$ °C	3.24	3.3	3.36	V
V_O	Output voltage	$I_O = 0$ to 800 mA, $V_{in} = 4.75$ to 10 V	3.16		3.44	V
ΔV_O	Line regulation	$V_{in} = 4.75$ to 15 V, $I_O = 0$ mA		1	30	mV
ΔV_O	Load regulation	$V_{in} = 4.75$ V, $I_O = 0$ to 800 mA		1	30	mV
ΔV_O	Temperature stability			0.5		%
ΔV_O	Long term stability	1000 hrs, $T_J = 125$ °C		0.3		%
V_{in}	Operating input voltage	$I_O = 100$ mA			15	V
I_d	Quiescent current	$V_{in} \leq 15$ V		5	10	mA
I_O	Output current	$V_{in} = 8.3$ V, $T_J = 25$ °C	800	950	1300	mA
eN	Output noise voltage	B = 10 Hz to 10 kHz, $T_J = 25$ °C		100		μ V
SVR	Supply voltage rejection	$I_O = 40$ mA, $f = 120$ Hz, $T_J = 25$ °C $V_{in} = 6.3$ V, $V_{ripple} = 1$ V _{PP}	60	75		dB
V_d	Dropout voltage	$I_O = 100$ mA, $T_J = 0$ to 125 °C		1	1.1	V
		$I_O = 500$ mA, $T_J = 0$ to 125 °C		1.05	1.15	
		$I_O = 800$ mA, $T_J = 0$ to 125 °C		1.10	1.2	
V_d	Dropout voltage	$I_O = 100$ mA			1.1	V
		$I_O = 500$ mA			1.2	
		$I_O = 800$ mA			1.3	
	Thermal regulation	$T_a = 25$ °C, 30 ms Pulse		0.01	0.1	%/W

Refer to the test circuits, $T_J = -40$ to $125\text{ }^\circ\text{C}$, $C_O = 10\text{ }\mu\text{F}$, unless otherwise specified.

Table 15. Electrical characteristics of LD1117#50C

Symbol	Parameter	Test condition	Min.	Typ.	Max.	Unit
V_O	Output voltage	$V_{in} = 7\text{ V}$, $I_O = 10\text{ mA}$, $T_J = 25\text{ }^\circ\text{C}$	4.9	5	5.1	V
V_O	Output voltage	$I_O = 0$ to 800 mA , $V_{in} = 6.5$ to 15 V	4.8		5.2	V
ΔV_O	Line regulation	$V_{in} = 6.5$ to 15 V , $I_O = 0\text{ mA}$		1	50	mV
ΔV_O	Load regulation	$V_{in} = 6.5\text{ V}$, $I_O = 0$ to 800 mA		1	50	mV
ΔV_O	Temperature stability			0.5		%
ΔV_O	Long term stability	1000 hrs, $T_J = 125\text{ }^\circ\text{C}$		0.3		%
V_{in}	Operating input voltage	$I_O = 100\text{ mA}$			15	V
I_d	Quiescent current	$V_{in} \leq 15\text{ V}$		5	10	mA
I_O	Output current	$V_{in} = 10\text{ V}$, $T_J = 25\text{ }^\circ\text{C}$	800	950	1300	mA
eN	Output noise voltage	$B = 10\text{ Hz}$ to 10 kHz , $T_J = 25\text{ }^\circ\text{C}$		100		μV
SVR	Supply voltage rejection	$I_O = 40\text{ mA}$, $f = 120\text{ Hz}$, $T_J = 25\text{ }^\circ\text{C}$ $V_{in} = 8\text{ V}$, $V_{ripple} = 1\text{ V}_{PP}$	60	75		dB
V_d	Dropout voltage	$I_O = 100\text{ mA}$, $T_J = 0$ to $125\text{ }^\circ\text{C}$		1	1.1	V
		$I_O = 500\text{ mA}$, $T_J = 0$ to $125\text{ }^\circ\text{C}$		1.05	1.15	
		$I_O = 800\text{ mA}$, $T_J = 0$ to $125\text{ }^\circ\text{C}$		1.10	1.2	
V_d	Dropout voltage	$I_O = 100\text{ mA}$			1.1	V
		$I_O = 500\text{ mA}$			1.2	
		$I_O = 800\text{ mA}$			1.3	
	Thermal regulation	$T_a = 25\text{ }^\circ\text{C}$, 30 ms Pulse		0.01	0.1	%/W

Refer to the test circuits, $T_J = -40$ to 125 °C, $C_O = 10$ μ F, unless otherwise specified.

Table 16. Electrical characteristics of LD1117C (adjustable)

Symbol	Parameter	Test condition	Min.	Typ.	Max.	Unit
V_{ref}	Reference voltage	$V_{in} - V_O = 2$ V, $I_O = 10$ mA, $T_J = 25$ °C	1.225	1.25	1.275	V
V_{ref}	Reference voltage	$I_O = 10$ to 800 mA, $V_{in} - V_O = 1.4$ to 10 V	1.2		1.3	V
ΔV_O	Line regulation	$V_{in} - V_O = 1.5$ to 13.75 V, $I_O = 10$ mA			1	%
ΔV_O	Load regulation	$V_{in} - V_O = 3$ V, $I_O = 10$ to 800 mA			1	%
ΔV_O	Temperature stability			0.5		%
ΔV_O	Long term stability	1000 hrs, $T_J = 125$ °C		0.3		%
V_{in}	Operating input voltage				15	V
I_{adj}	Adjustment pin current	$V_{in} \leq 15$ V		60	120	μ A
ΔI_{adj}	Adjustment pin current change	$V_{in} - V_O = 1.4$ to 10 V, $I_O = 10$ to 800 mA		1	10	μ A
$I_{O(min)}$	Minimum load current	$V_{in} = 15$ V		2	5	mA
I_O	Output current	$V_{in} - V_O = 5$ V, $T_J = 25$ °C	800	950	1300	mA
eN	Output noise (% V_O)	$B = 10$ Hz to 10 kHz, $T_J = 25$ °C		0.003		%
SVR	Supply voltage rejection	$I_O = 40$ mA, $f = 120$ Hz, $T_J = 25$ °C $V_{in} - V_O = 3$ V, $V_{ripple} = 1$ V _{PP}	60	75		dB
V_d	Dropout voltage	$I_O = 100$ mA, $T_J = 0$ to 125 °C		1	1.1	V
		$I_O = 500$ mA, $T_J = 0$ to 125 °C		1.05	1.15	
		$I_O = 800$ mA, $T_J = 0$ to 125 °C		1.10	1.2	
V_d	Dropout voltage	$I_O = 100$ mA			1.1	V
		$I_O = 500$ mA			1.2	
		$I_O = 800$ mA			1.3	
	Thermal regulation	$T_a = 25$ °C, 30 ms Pulse		0.01	0.1	%/W

6 Typical application

Figure 5. Negative supply

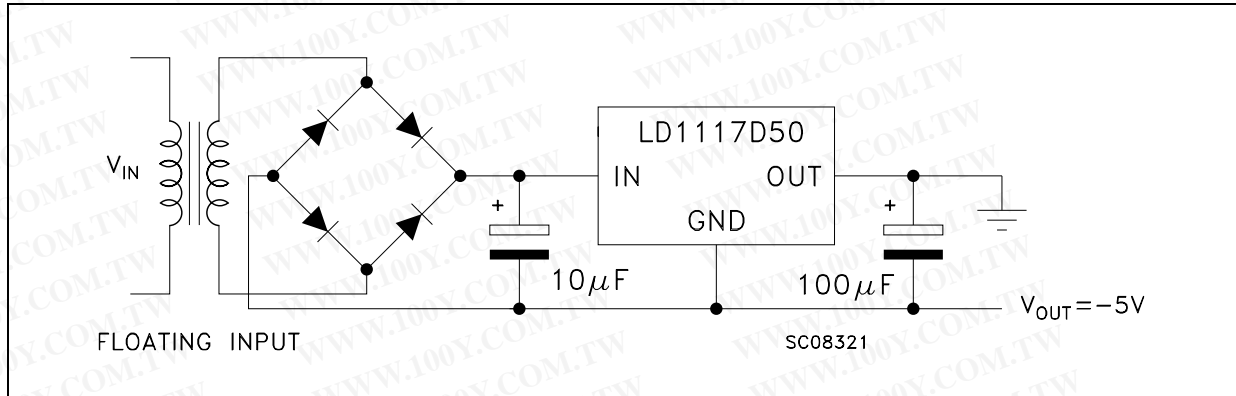

Figure 6. Active terminator for SCSI-2 bus

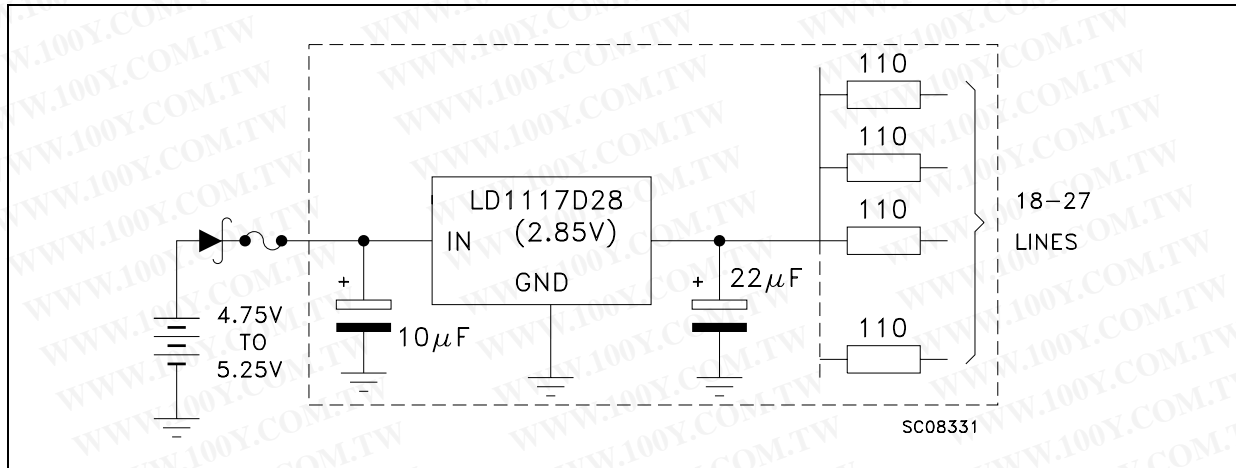

Figure 7. Circuit for increasing output voltage

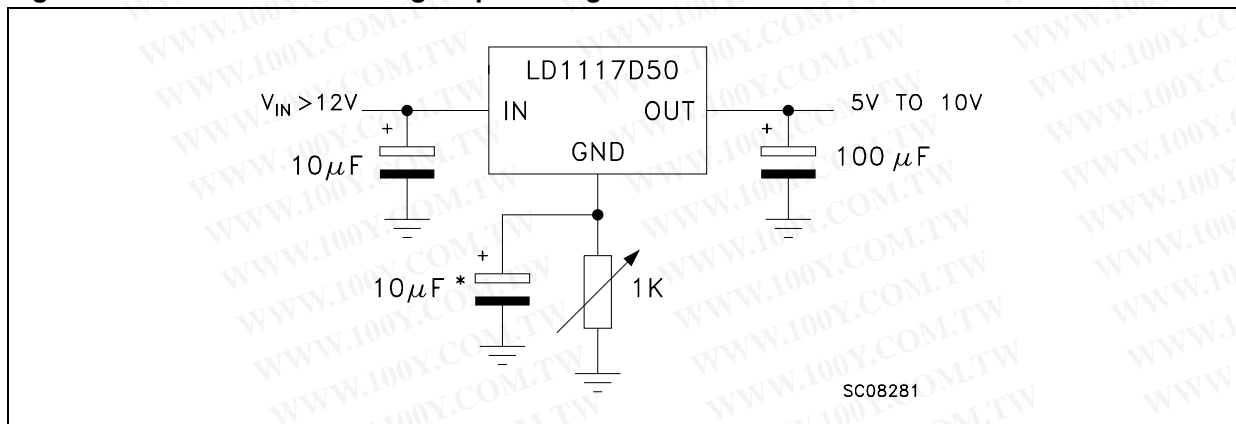

Figure 8. Voltage regulator with reference

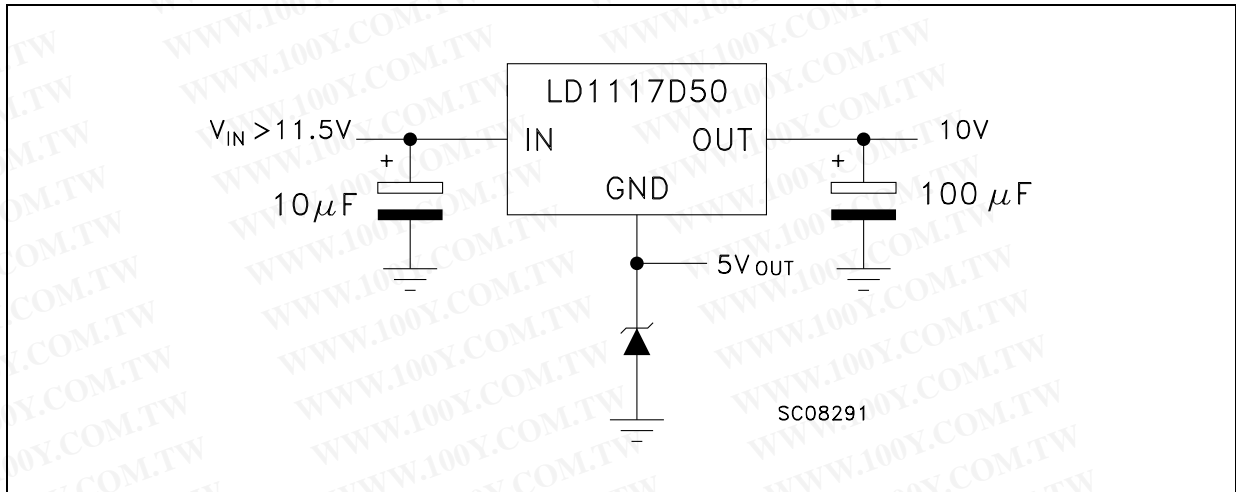

Figure 9. Battery backed-up regulated supply

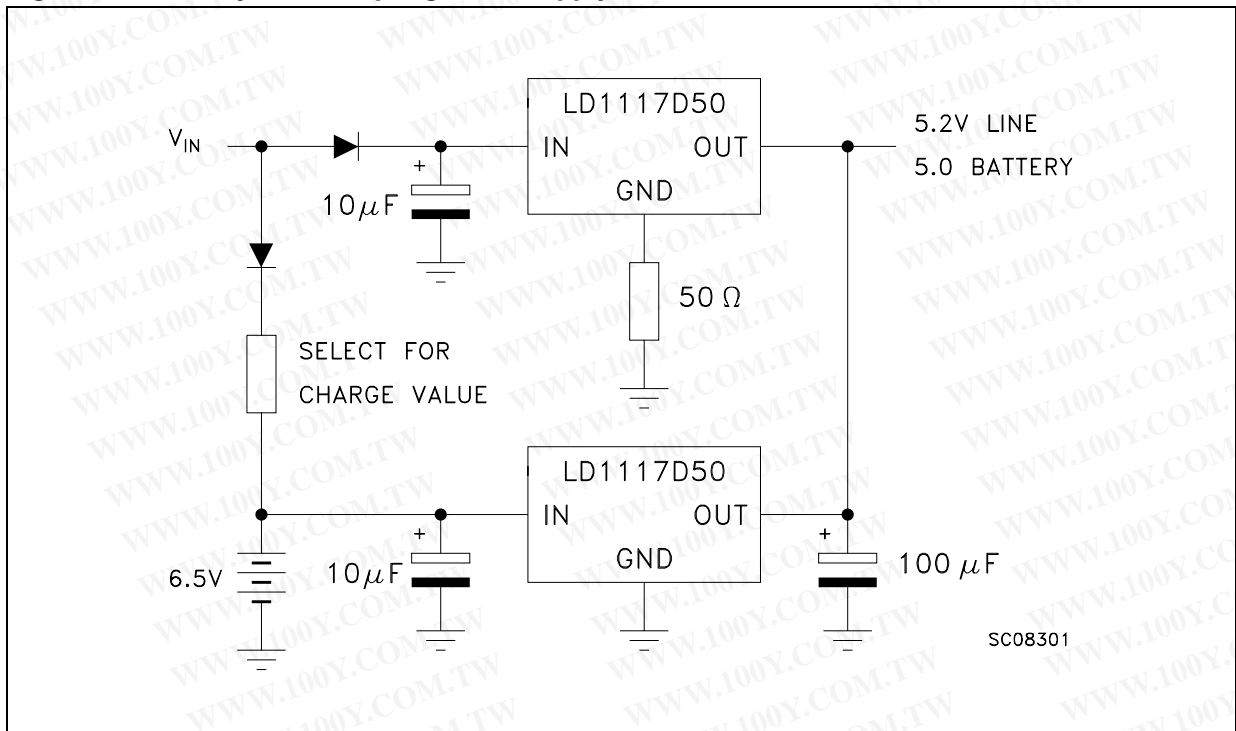
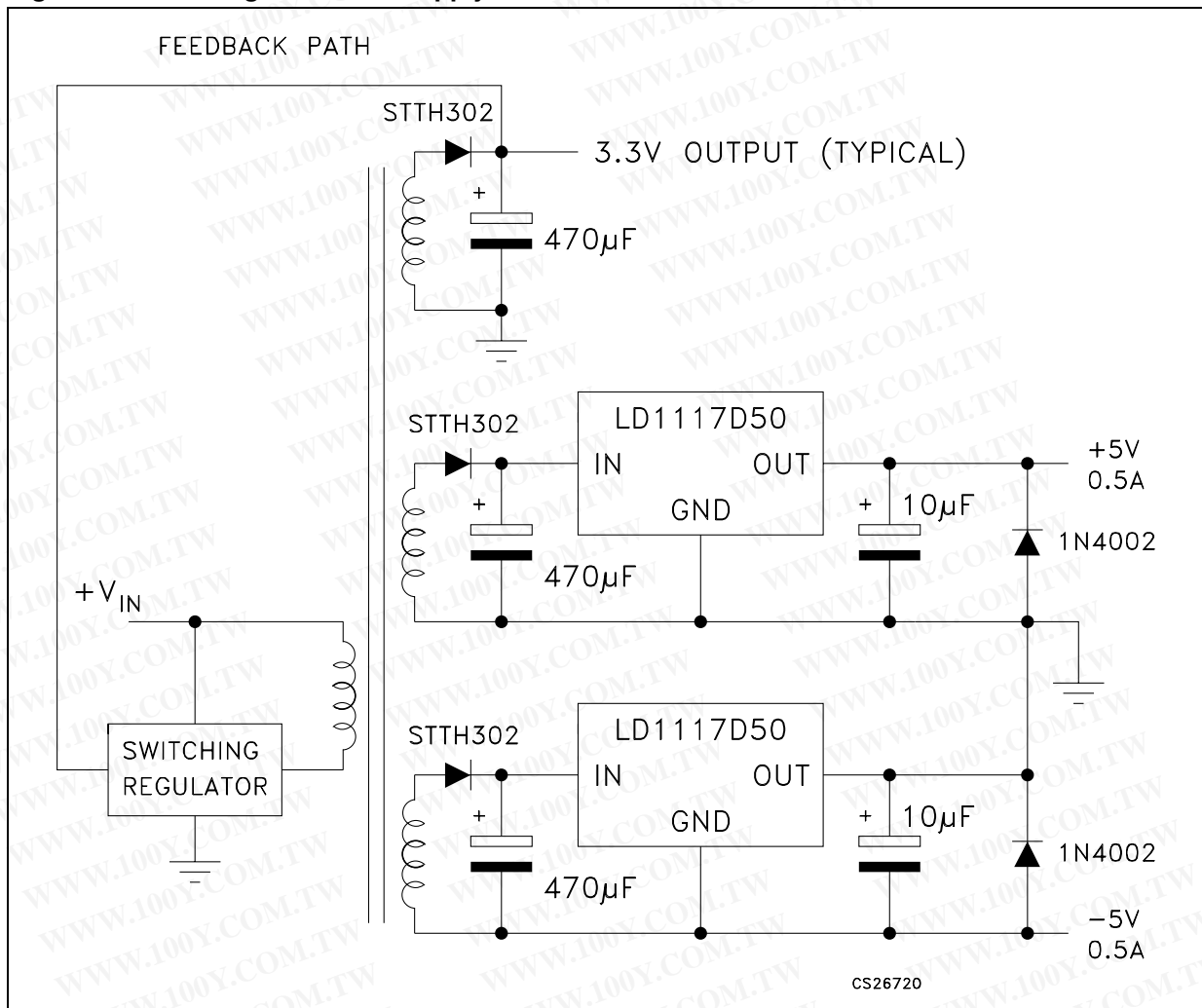

Figure 10. Post-regulated dual supply



7 LD1117 adjustable: application note

The LD1117 adjustable has a thermal stabilized 1.25 ± 0.012 V reference voltage between the OUT and ADJ pins. I_{ADJ} is 60 μ A typ. (120 μ A max.) and ΔI_{ADJ} is 1 μ A typ. (5 μ A max.).

R_1 is normally fixed to 120 Ω . From [Figure 10](#) we obtain:

$$V_{OUT} = V_{REF} + R_2 (I_{ADJ} + I_{R1}) = V_{REF} + R_2 (I_{ADJ} + V_{REF} / R_1) = V_{REF} (1 + R_2 / R_1) + R_2 \times I_{ADJ}$$

In normal application R_2 value is in the range of few k Ω , so the $R_2 \times I_{ADJ}$ product could not be considered in the V_{OUT} calculation; then the above expression becomes:

$$V_{OUT} = V_{REF} (1 + R_2 / R_1)$$

In order to have the better load regulation it is important to realize a good Kelvin connection of R_1 and R_2 resistors. In particular R_1 connection must be realized very close to OUT and ADJ pin, while R_2 ground connection must be placed as near as possible to the negative Load pin. Ripple rejection can be improved by introducing a 10 μ F electrolytic capacitor placed in parallel to the R_2 resistor (see [Figure 11](#)).

Figure 11. Adjustable output voltage application

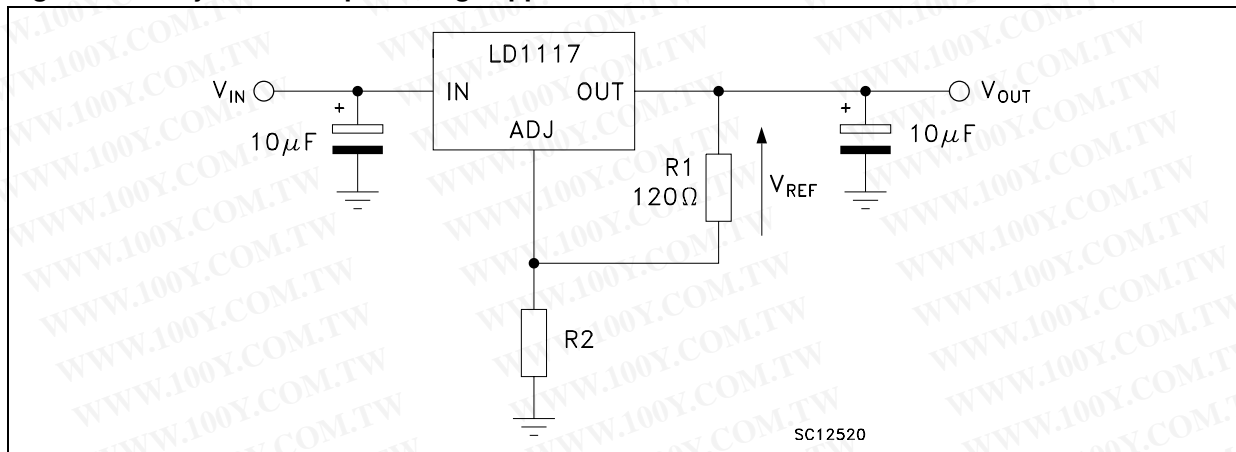
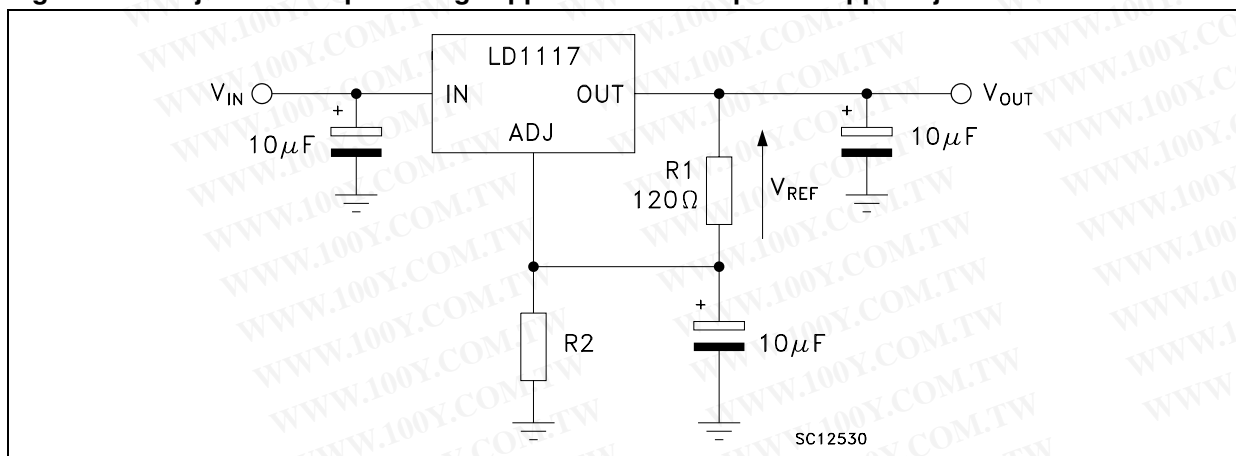

Figure 12. Adjustable output voltage application with improved ripple rejection



8 Package mechanical data

In order to meet environmental requirements, ST offers these devices in different grades of ECOPACK® packages, depending on their level of environmental compliance. ECOPACK® specifications, grade definitions and product status are available at: www.st.com. ECOPACK® is an ST trademark.

Table 17. TO-220 mechanical data

Dim.	Type STD - ST Dual Gauge			Type STD - ST Single Gauge		
	mm.			mm.		
	Min.	Typ.	Max.	Min.	Typ.	Max.
A	4.40		4.60	4.40		4.60
b	0.61		0.88	0.61		0.88
b1	1.14		1.70	1.14		1.70
c	0.48		0.70	0.48		0.70
D	15.25		15.75	15.25		15.75
D1		1.27				
E	10.00		10.40	10.00		10.40
e	2.40		2.70	2.40		2.70
e1	4.95		5.15	4.95		5.15
F	1.23		1.32	0.51		0.60
H1	6.20		6.60	6.20		6.60
J1	2.40		2.72	2.40		2.72
L	13.00		14.00	13.00		14.00
L1	3.50		3.93	3.50		3.93
L20		16.40			16.40	
L30		28.90			28.90	
∅P	3.75		3.85	3.75		3.85
Q	2.65		2.95	2.65		2.95

In spite of some difference in tolerances, the packages are compatible.

Figure 13. Drawing dimension TO-220 (type STD-ST Dual Gauge)

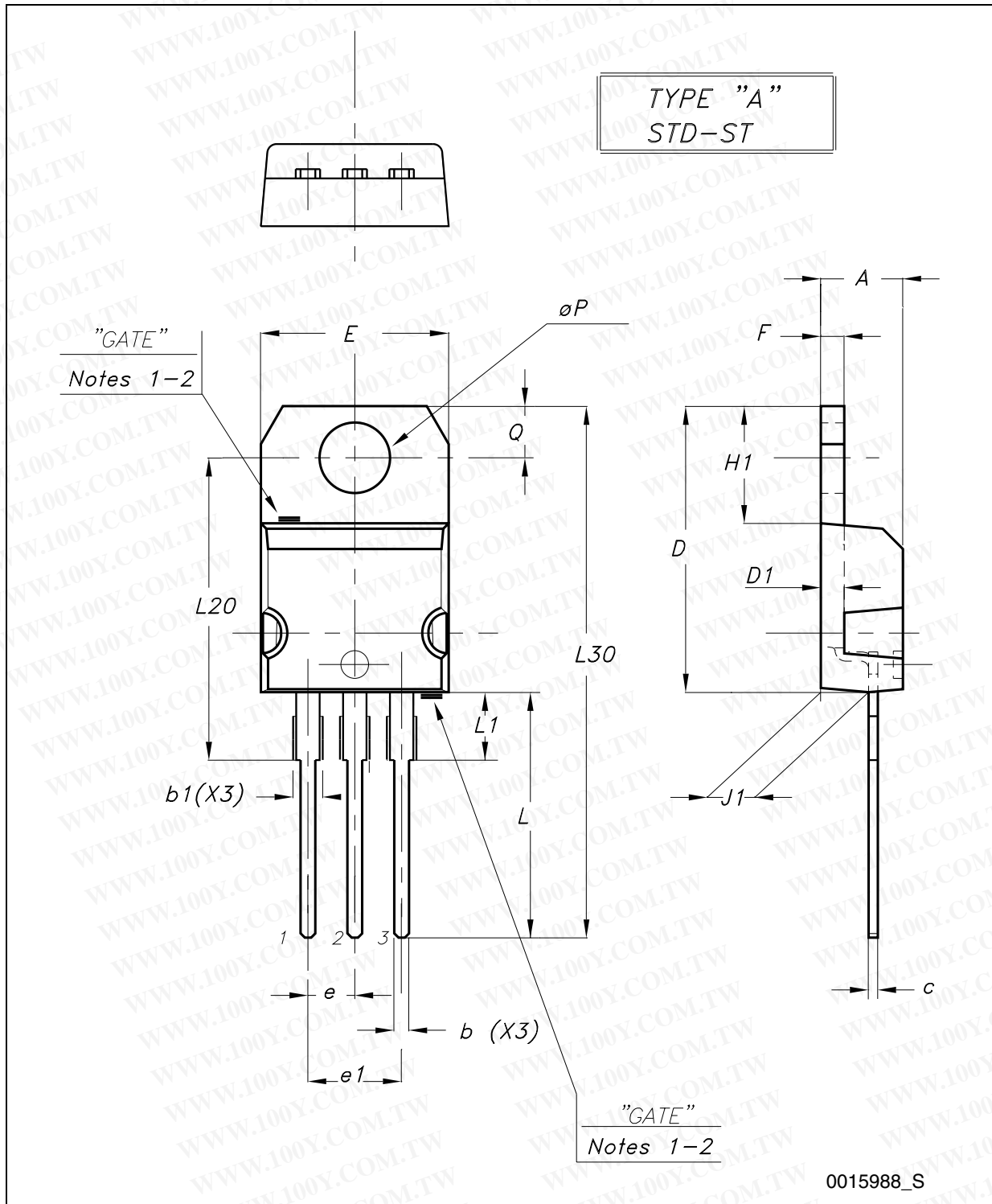

- Note: 1 Maximum resin gate protrusion: 0.5 mm.
 2 Resin gate position is accepted in each of the two positions shown on the drawing, or their symmetrical.

SOT-223 mechanical data

Dim.	mm.			mils.		
	Min.	Typ.	Max.	Min.	Typ.	Max.
A			1.8			70.9
A1	0.02		0.1	0.8		3.9
B	0.6	0.7	0.85	23.6	27.6	33.5
B1	2.9	3	3.15	114.2	118.1	124.0
c	0.24	0.26	0.35	9.4	10.2	13.8
D	6.3	6.5	6.7	248.0	255.9	263.8
e		2.3			90.6	
e1		4.6			181.1	
E	3.3	3.5	3.7	129.9	137.8	145.7
H	6.7	7	7.3	263.8	275.7	287.5
V			10°			10°

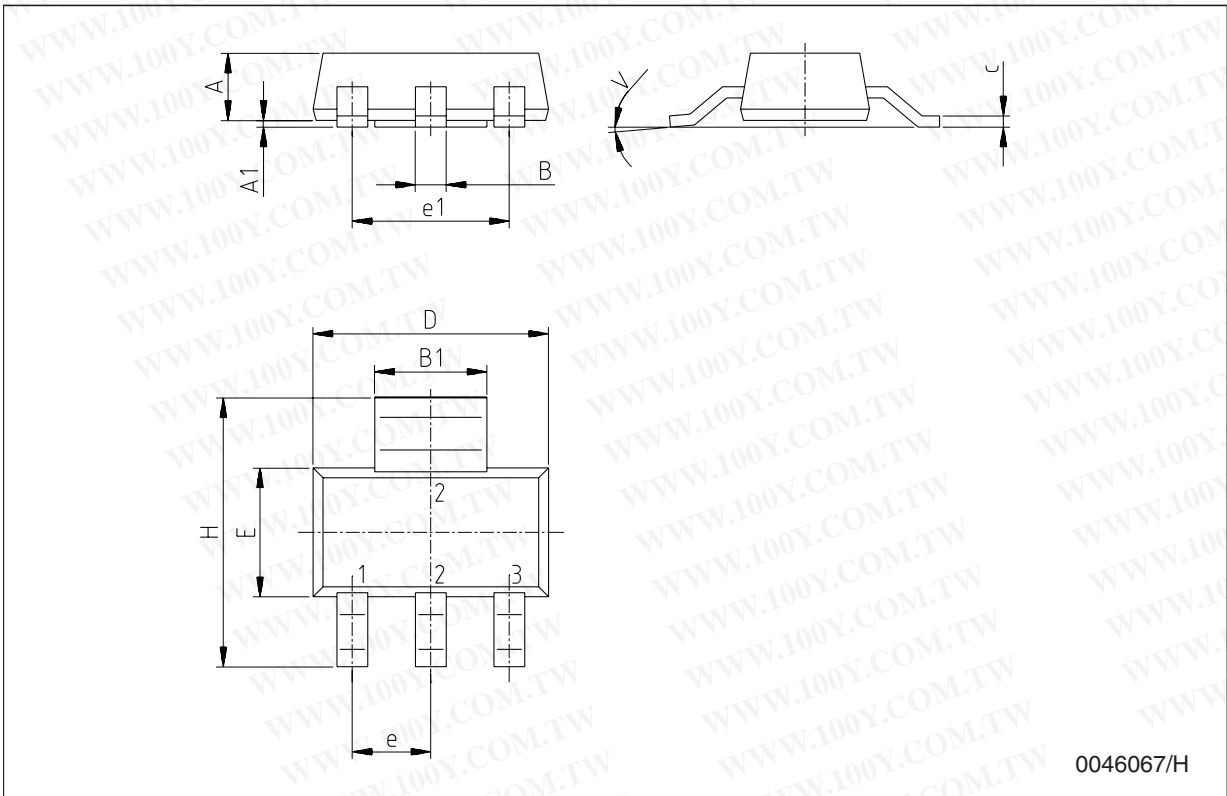

SO-8 mechanical data

Dim.	mm.			inch.		
	Min.	Typ.	Max.	Min.	Typ.	Max.
A	1.35		1.75	0.053		0.069
A1	0.10		0.25	0.04		0.010
A2	1.10		1.65	0.043		0.065
B	0.33		0.51	0.013		0.020
C	0.19		0.25	0.007		0.010
D	4.80		5.00	0.189		0.197
E	3.80		4.00	0.150		0.157
e		1.27			0.050	
H	5.80		6.20	0.228		0.244
h	0.25		0.50	0.010		0.020
L	0.40		1.27	0.016		0.050
k	8° (max.)					
ddd			0.1			0.04

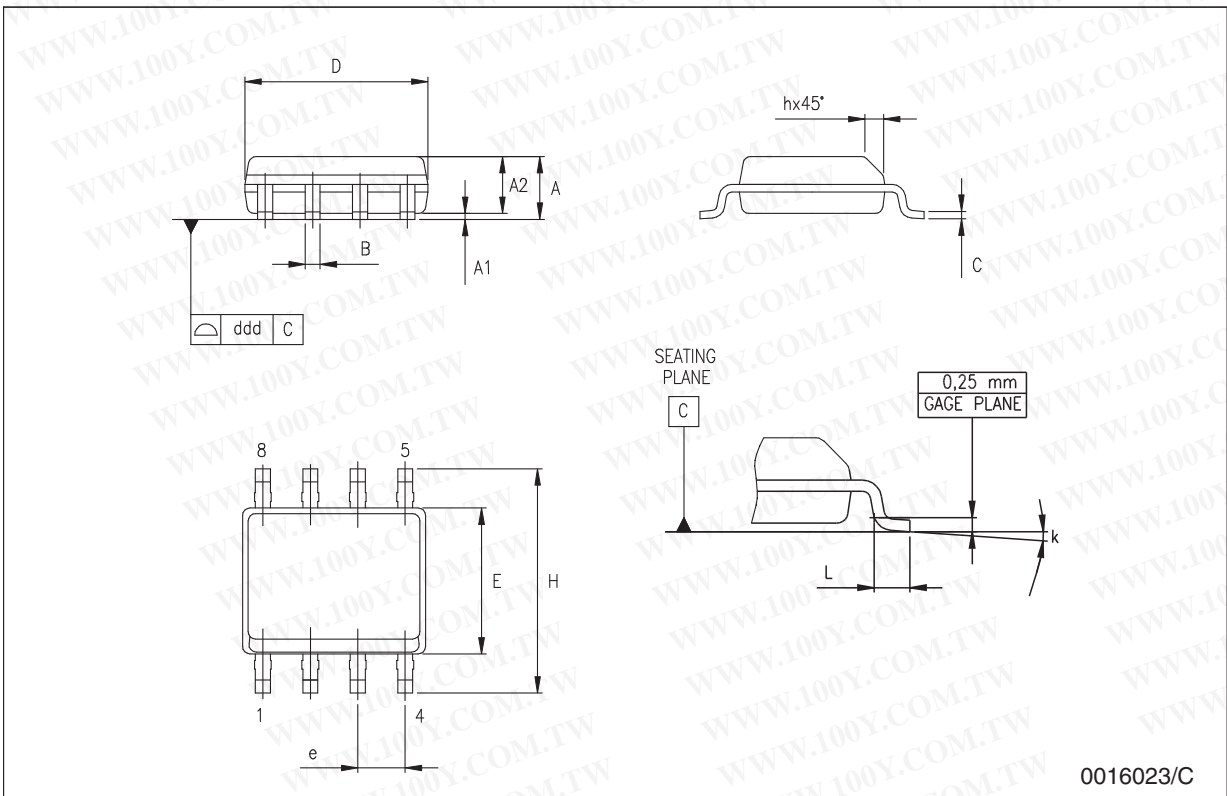

0016023/C

Figure 17. Drawing dimension DPAK (type STD-ST)

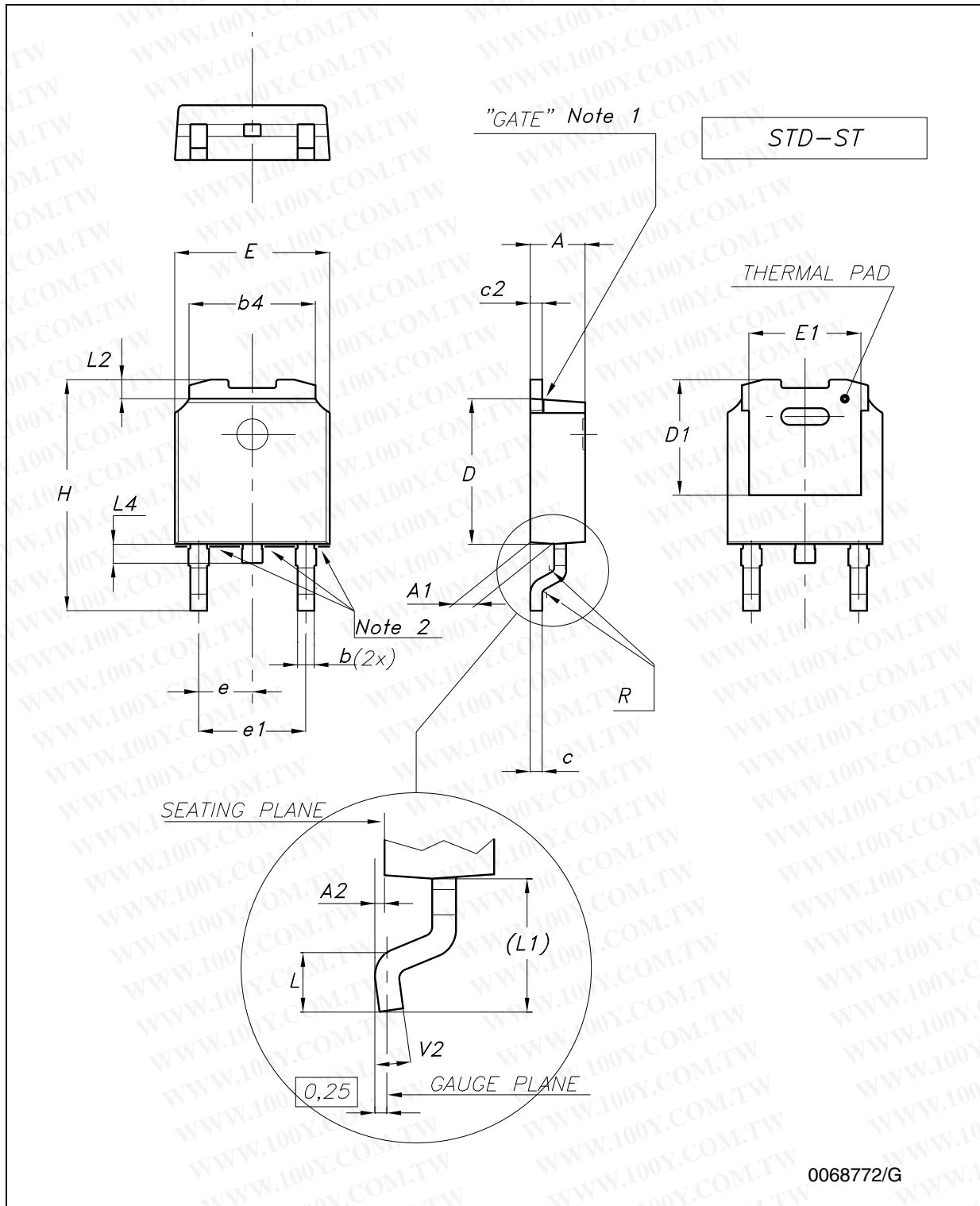

Note: 1 Maximum resin gate protrusion: 0.5 mm.
 2 Maximum resin protrusion: 0.25 mm.

Figure 18. Drawing dimension DPAK (type Fujitsu-subcon.)

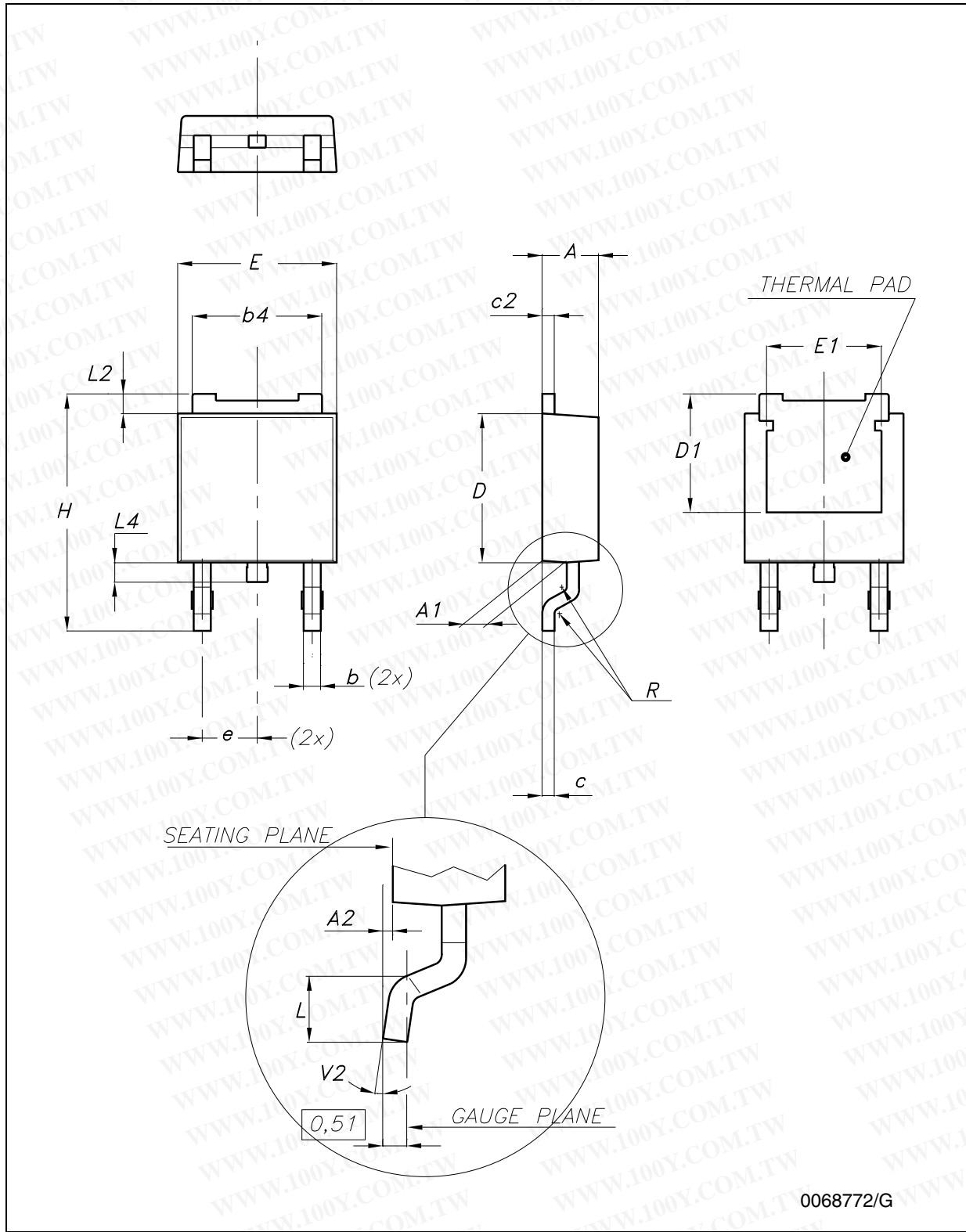

0068772/G

Figure 19. Drawing dimension DPAK (type IDS-subcon.)

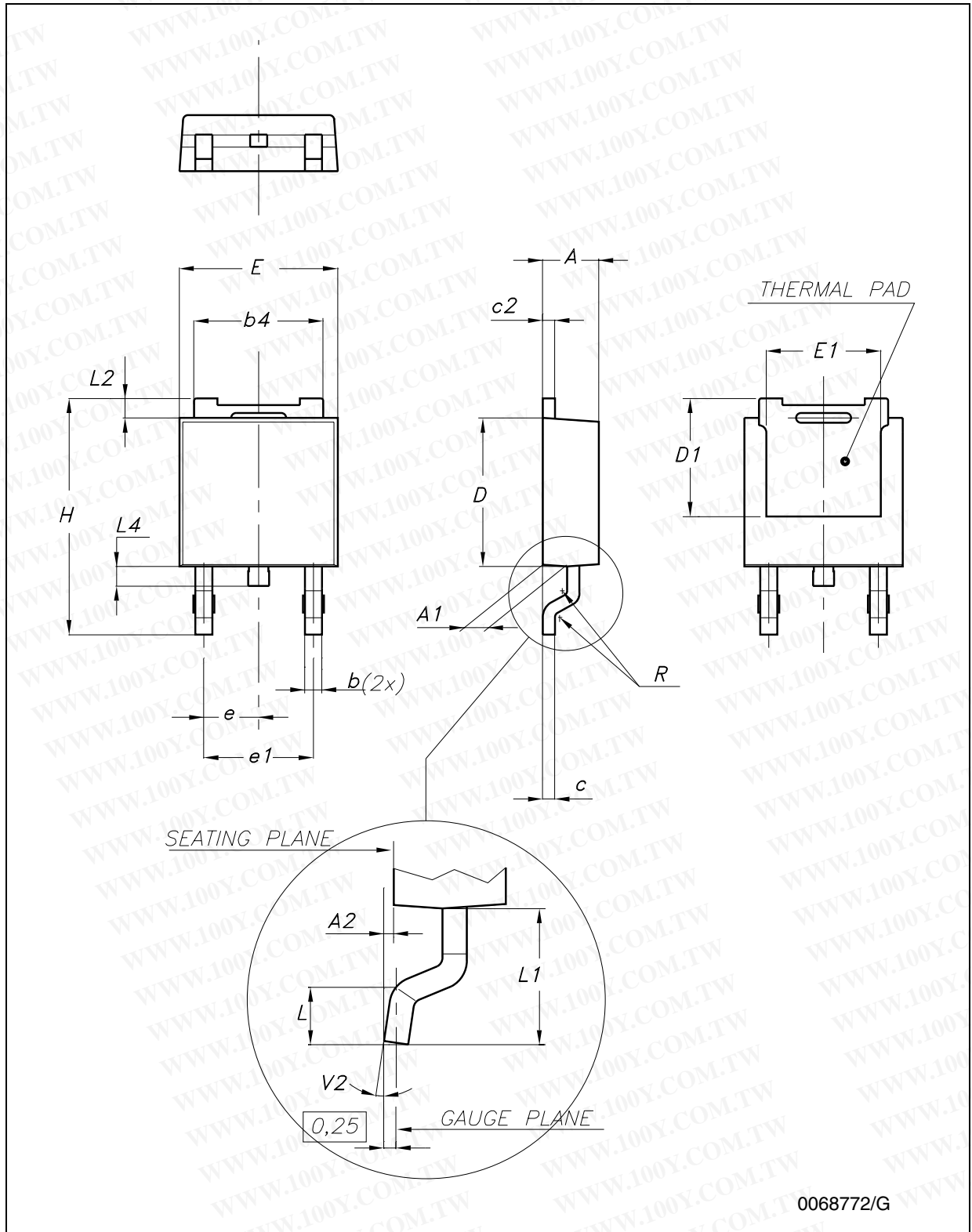

0068772/G

Table 18. DPAK mechanical data

Dim.	Type STD-ST			Type Fujitsu-subcon.			Type IDS-subcon		
	mm.			mm.			mm.		
	Min.	Typ.	Max.	Min.	Typ.	Max.	Min.	Typ.	Max.
A	2.20		2.40	2.25	2.30	2.35	2.19		2.38
A1	0.90		1.10	0.96		1.06	0.89		1.14
A2	0.03		0.23	0		0.10	0.03		0.23
b	0.64		0.90	0.76		0.86	0.64		0.88
b4	5.20		5.40	5.28		5.38	5.21		5.46
c	0.45		0.60	0.46		0.56	0.46		0.58
c2	0.48		0.60	0.46		0.56	0.46		0.58
D	6.00		6.20	6.05		6.15	5.97		6.22
D1		5.10		5.27		5.47		5.20	
E	6.40		6.60	6.55	6.60	6.65	6.35		6.73
E1		4.70			4.77			4.70	
e		2.28		2.23	2.28	2.33		2.28	
e1	4.40		4.60				4.51		4.61
H	9.35		10.10	9.90		10.30	9.40		10.42
L	1.00			1.40		1.60	0.90		
L1		2.80					2.50		2.65
L2		0.80		1.03		1.13	0.89		1.27
L4	0.60		1.00	0.70		0.90	0.64		1.02
R		0.20			0.40			0.20	
V2	0°		8°	0°		8°	0°		8°

Note: The DPAK package coming from the two subcontractors (Fujitsu and IDS) are fully compatible with the ST's package suggested footprint.

Figure 20. DPAK footprint recommended data

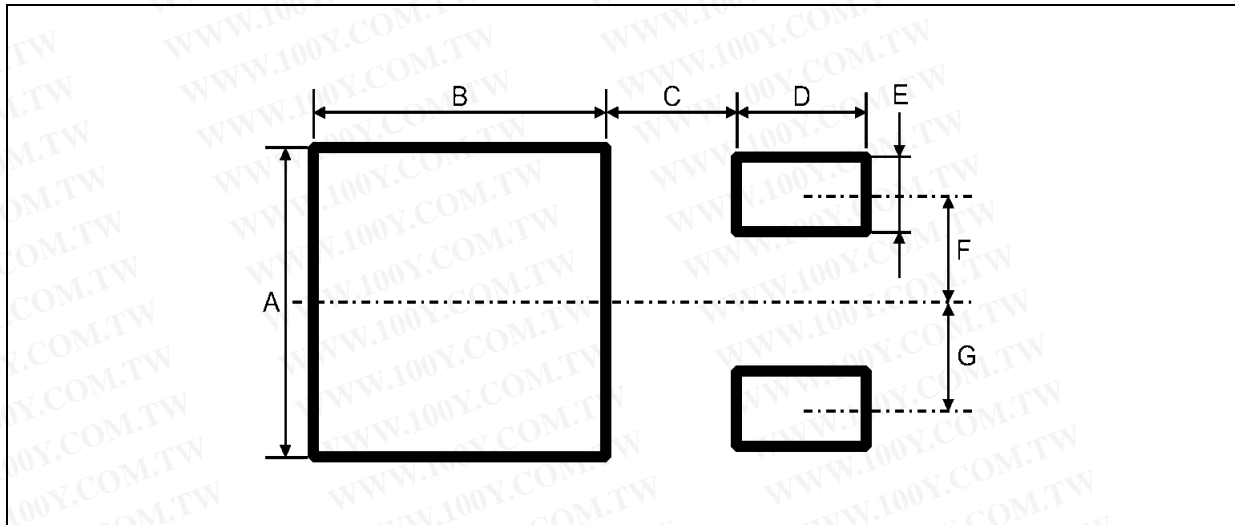
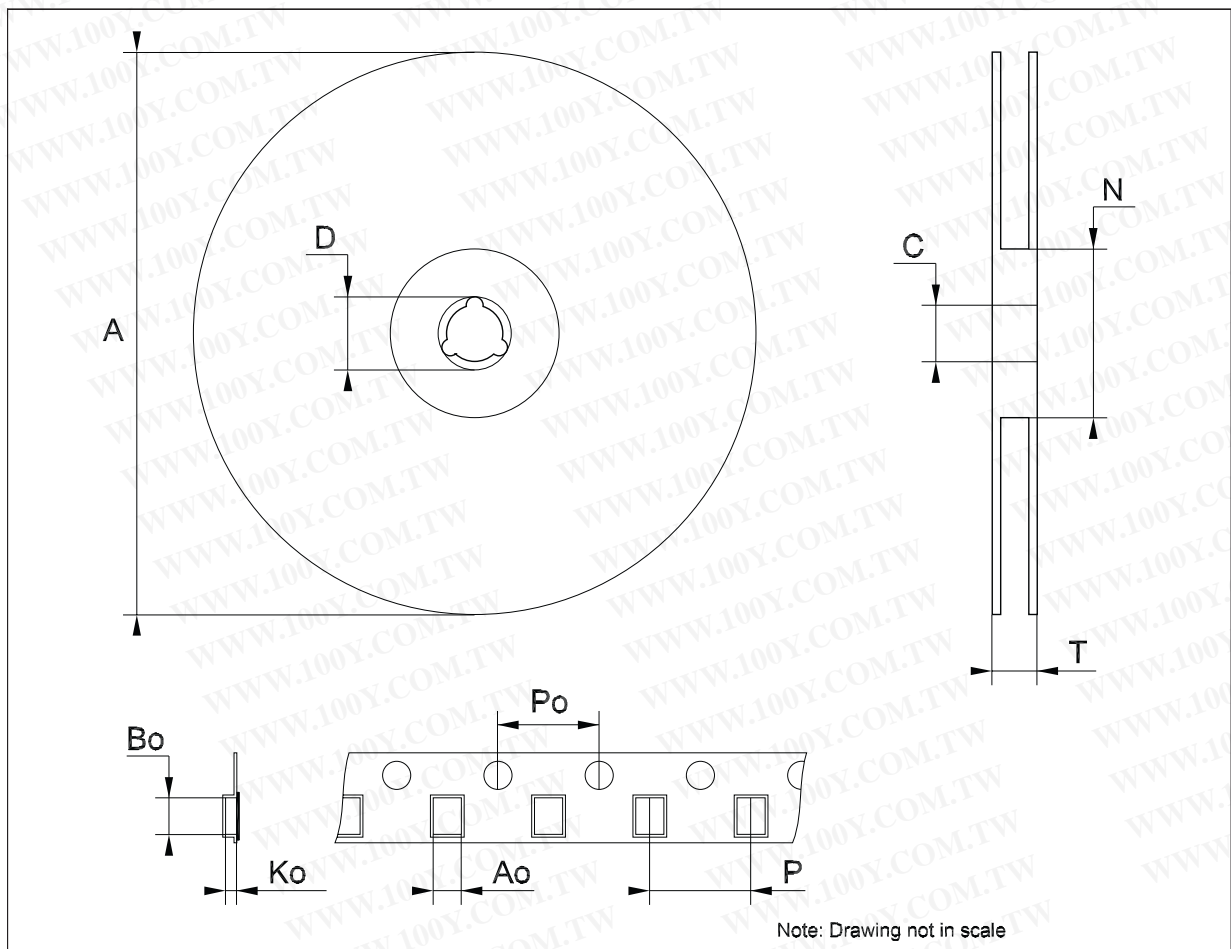

Table 19. Footprint data

	Values	
	mm.	inch.
A	6.70	0.264
B	6.70	0.64
C	1.8	0.070
D	3.0	0.118
E	1.60	0.063
F	2.30	0.091
G	2.30	0.091

Tape & reel SOT223 mechanical data

Dim.	mm.			inch.		
	Min.	Typ.	Max.	Min.	Typ.	Max.
A			330			12.992
C	12.8	13.0	13.2	0.504	0.512	0.519
D	20.2			0.795		
N	60			2.362		
T			14.4			0.567
Ao	6.73	6.83	6.93	0.265	0.269	0.273
Bo	7.32	7.42	7.52	0.288	0.292	0.296
Ko	1.78		2	0.070		0.078
Po	3.9	4.0	4.1	0.153	0.157	0.161
P	7.9	8.0	8.1	0.311	0.315	0.319



Tape & reel SO-8 mechanical data

Dim.	mm.			inch.		
	Min.	Typ.	Max.	Min.	Typ.	Max.
A			330			12.992
C	12.8		13.2	0.504		0.519
D	20.2			0.795		
N	60			2.362		
T			22.4			0.882
Ao	8.1		8.5	0.319		0.335
Bo	5.5		5.9	0.216		0.232
Ko	2.1		2.3	0.082		0.090
Po	3.9		4.1	0.153		0.161
P	7.9		8.1	0.311		0.319

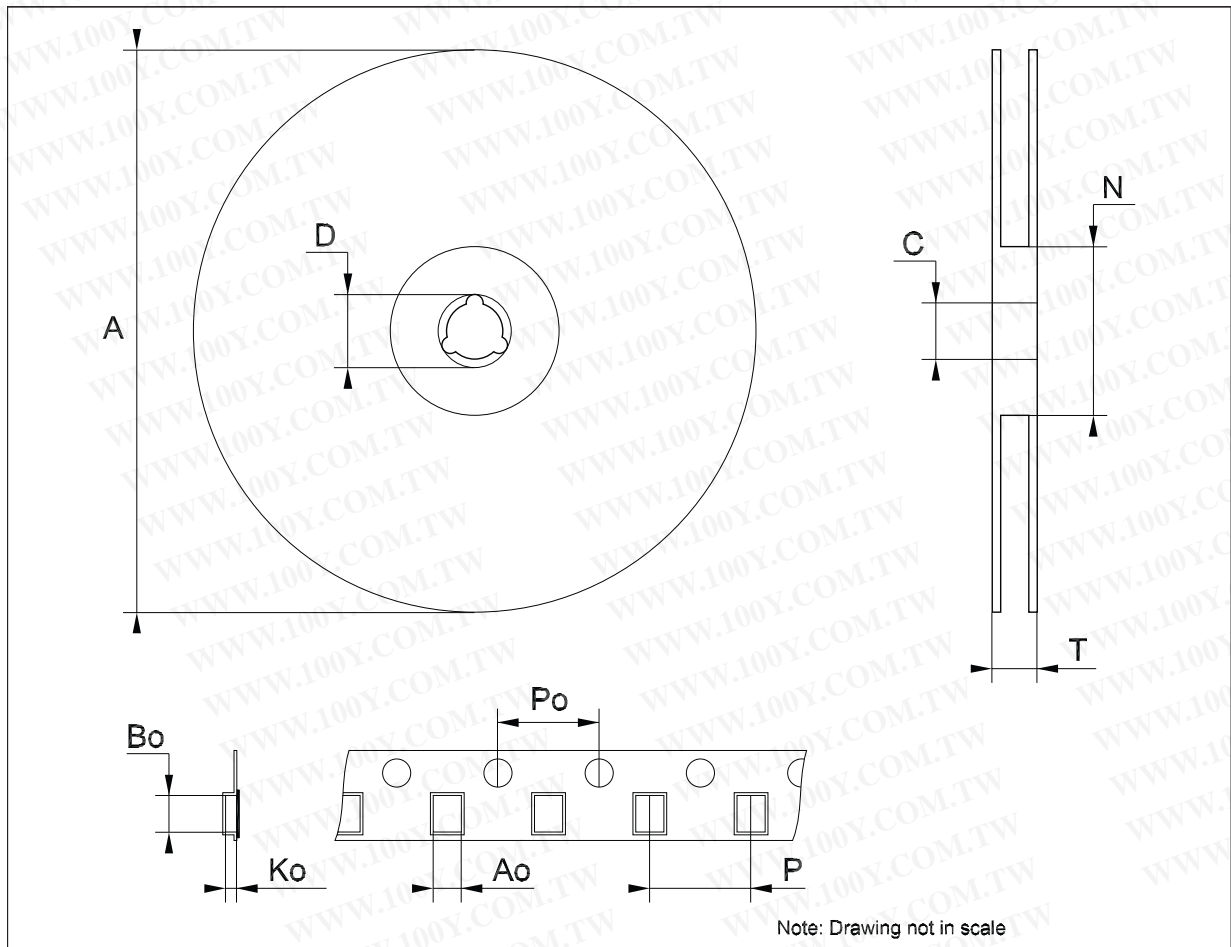

Tape & reel DPAK-PPAK mechanical data

Dim.	mm.			inch.		
	Min.	Typ.	Max.	Min.	Typ.	Max.
A			330			12.992
C	12.8	13.0	13.2	0.504	0.512	0.519
D	20.2			0.795		
N	60			2.362		
T			22.4			0.882
Ao	6.80	6.90	7.00	0.268	0.272	0.276
Bo	10.40	10.50	10.60	0.409	0.413	0.417
Ko	2.55	2.65	2.75	0.100	0.104	0.105
Po	3.9	4.0	4.1	0.153	0.157	0.161
P	7.9	8.0	8.1	0.311	0.315	0.319

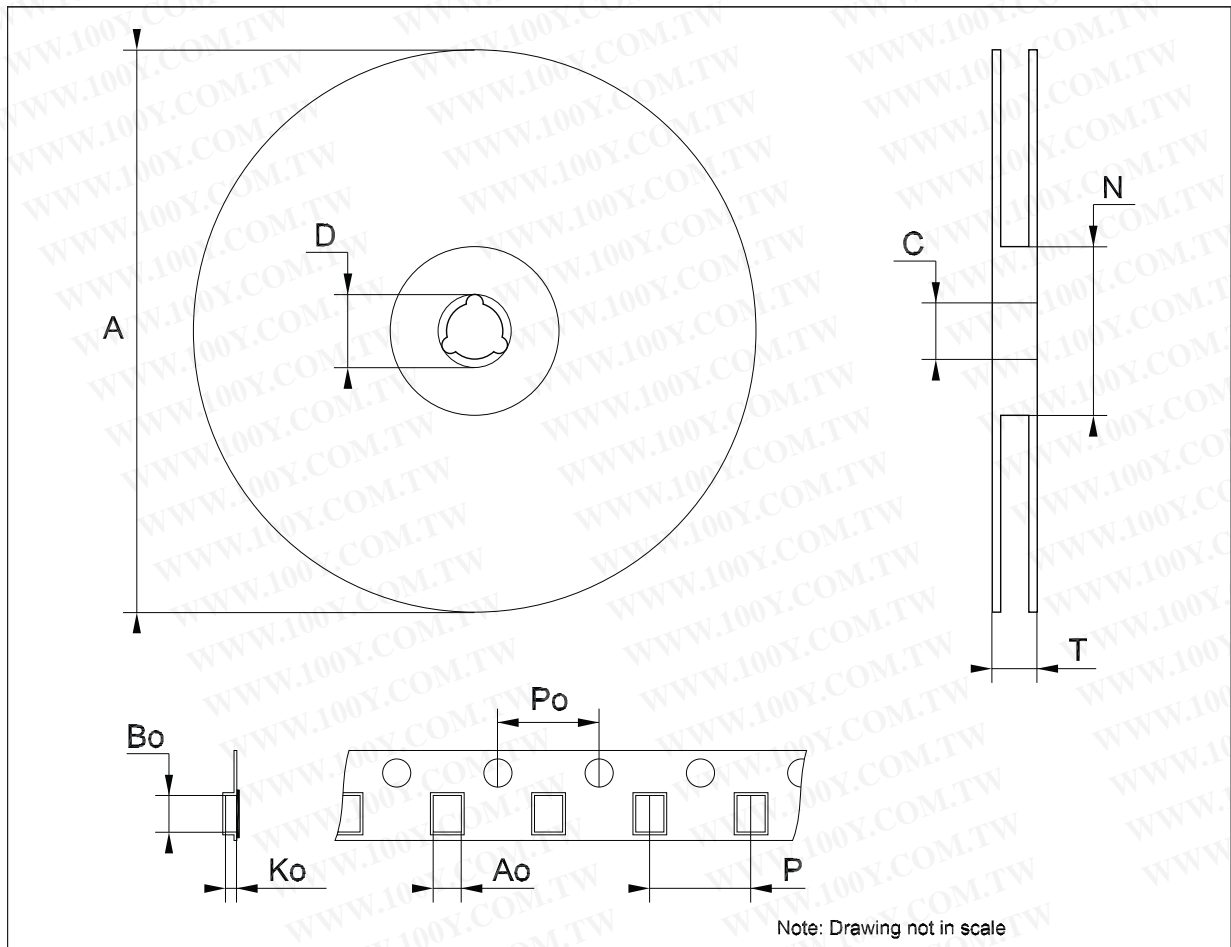

9 Order codes

Table 20. Order codes

Packages					
SOT-223	SO-8	DPAK	DPAK (T & R)	TO-220	Output voltages
LD1117S12TR	LD1117D12TR ⁽¹⁾	LD1117DT12 ⁽¹⁾	LD1117DT12TR		1.2 V
LD1117S12CTR	LD1117D12CTR ⁽¹⁾	LD1117DT12C ⁽¹⁾	LD1117DT12CTR	LD1117V12C ⁽¹⁾	1.2 V
LD1117S18TR	LD1117D18TR ⁽¹⁾		LD1117DT18TR	LD1117V18	1.8 V
LD1117S18CTR	LD1117D18CTR ⁽¹⁾		LD1117DT18CTR	LD1117V18C ⁽¹⁾	1.8 V
LD1117S25TR	LD1117D25TR ⁽¹⁾		LD1117DT25TR		2.5 V
LD1117S25CTR	LD1117D25CTR ⁽¹⁾		LD1117DT25CTR		2.5 V
LD1117S30TR					3 V
LD1117S33TR	LD1117D33TR		LD1117DT33TR	LD1117V33	3.3 V
LD1117S33CTR	LD1117D33CTR		LD1117DT33CTR	LD1117V33C	3.3 V
LD1117S50TR			LD1117DT50TR	LD1117V50	5 V
LD1117S50CTR			LD1117DT50CTR	LD1117V50C	5 V
LD1117STR			LD1117DTTR	LD1117V	ADJ from 1.25 to 15V
LD1117SC-R	LD1117DC-R ⁽¹⁾	LD1117DTC ⁽¹⁾	LD1117DTC-R	LD1117VC ⁽¹⁾	ADJ from 1.25 to 15V

1. Available on request.

10 Revision history

Table 21. Document revision history

Date	Revision	Changes
22-Sep-2004	15	Add new part number #12C; typing error: note on table 2.
25-Oct-2004	16	Add V_{ref} reference voltage on table 12.
18-Jul-2005	17	The DPAK mechanical data updated.
25-Nov-2005	18	The TO220FM package removed.
14-Dec-2005	19	The T_{op} on table 2 updated.
06-Dec-2006	20	DPAK mechanical data updated and added footprint data.
05-Apr-2007	21	Order codes updated.
30-Nov-2007	22	Added Table 1 .
16-Apr-2008	23	Modified: Table 20 on page 40 .
08-Jul-2008	24	Added note 1. on page 7 .
30-Mar-2009	25	Modified: V_{IN} max value Table 5 on page 10 and Figure 10 on page 24 .
29-Jul-2009	26	Modified: Table 20 on page 40 .
03-Feb-2010	27	Modified Table 11 on page 16 .
22-Mar-2010	28	Added: Table 17 on page 26 , Figure 13 on page 27 , Figure 14 on page 28 , Figure 15 and Figure 16 on page 29 .
15-Nov-2010	29	Modified: R_{thJC} value for TO-220 Table 3 on page 7 .

勝特力材料 886-3-5753170
勝特力电子(上海) 86-21-34970699
勝特力电子(深圳) 86-755-83298787
[Http://www.100y.com.tw](http://www.100y.com.tw)

Please Read Carefully:

Information in this document is provided solely in connection with ST products. STMicroelectronics NV and its subsidiaries ("ST") reserve the right to make changes, corrections, modifications or improvements, to this document, and the products and services described herein at any time, without notice.

All ST products are sold pursuant to ST's terms and conditions of sale.

Purchasers are solely responsible for the choice, selection and use of the ST products and services described herein, and ST assumes no liability whatsoever relating to the choice, selection or use of the ST products and services described herein.

No license, express or implied, by estoppel or otherwise, to any intellectual property rights is granted under this document. If any part of this document refers to any third party products or services it shall not be deemed a license grant by ST for the use of such third party products or services, or any intellectual property contained therein or considered as a warranty covering the use in any manner whatsoever of such third party products or services or any intellectual property contained therein.

UNLESS OTHERWISE SET FORTH IN ST'S TERMS AND CONDITIONS OF SALE ST DISCLAIMS ANY EXPRESS OR IMPLIED WARRANTY WITH RESPECT TO THE USE AND/OR SALE OF ST PRODUCTS INCLUDING WITHOUT LIMITATION IMPLIED WARRANTIES OF MERCHANTABILITY, FITNESS FOR A PARTICULAR PURPOSE (AND THEIR EQUIVALENTS UNDER THE LAWS OF ANY JURISDICTION), OR INFRINGEMENT OF ANY PATENT, COPYRIGHT OR OTHER INTELLECTUAL PROPERTY RIGHT.

UNLESS EXPRESSLY APPROVED IN WRITING BY AN AUTHORIZED ST REPRESENTATIVE, ST PRODUCTS ARE NOT RECOMMENDED, AUTHORIZED OR WARRANTED FOR USE IN MILITARY, AIR CRAFT, SPACE, LIFE SAVING, OR LIFE SUSTAINING APPLICATIONS, NOR IN PRODUCTS OR SYSTEMS WHERE FAILURE OR MALFUNCTION MAY RESULT IN PERSONAL INJURY, DEATH, OR SEVERE PROPERTY OR ENVIRONMENTAL DAMAGE. ST PRODUCTS WHICH ARE NOT SPECIFIED AS "AUTOMOTIVE GRADE" MAY ONLY BE USED IN AUTOMOTIVE APPLICATIONS AT USER'S OWN RISK.

Resale of ST products with provisions different from the statements and/or technical features set forth in this document shall immediately void any warranty granted by ST for the ST product or service described herein and shall not create or extend in any manner whatsoever, any liability of ST.

ST and the ST logo are trademarks or registered trademarks of ST in various countries.

Information in this document supersedes and replaces all information previously supplied.

The ST logo is a registered trademark of STMicroelectronics. All other names are the property of their respective owners.

© 2010 STMicroelectronics - All rights reserved

STMicroelectronics group of companies

Australia - Belgium - Brazil - Canada - China - Czech Republic - Finland - France - Germany - Hong Kong - India - Israel - Italy - Japan - Malaysia - Malta - Morocco - Philippines - Singapore - Spain - Sweden - Switzerland - United Kingdom - United States of America

www.st.com