



勝特力材料 886-3-5753170  
勝特力电子(上海) 86-21-34970699  
勝特力电子(深圳) 86-755-83298787  
[Http://www.100y.com.tw](http://www.100y.com.tw)

# L78LxxAB, L78LxxAC, L78LxxC

## Positive voltage regulators

Datasheet — production data

### Features

- Output current up to 100 mA
- Output voltages of 3.3; 5; 6; 8; 9; 10; 12; 15; 18; 24 V
- Thermal overload protection
- Short-circuit protection
- No external components are required
- Available in either  $\pm 4\%$  (AC) or  $\pm 8\%$  (C) selection

### Description

The L78Lxx series of three-terminal positive regulators employ internal current limiting and thermal shutdown, making them essentially indestructible. If adequate heat-sink is provided, they can deliver up to 100 mA output current. They are intended as fixed voltage regulators in a wide range of applications including local or on-card regulation for elimination of noise and distribution problems associated with single-point regulation. In addition, they can be used with power pass elements to make high-current voltage regulators. The L78Lxx series used as Zener diode/resistor combination replacement, offers an effective output impedance improvement

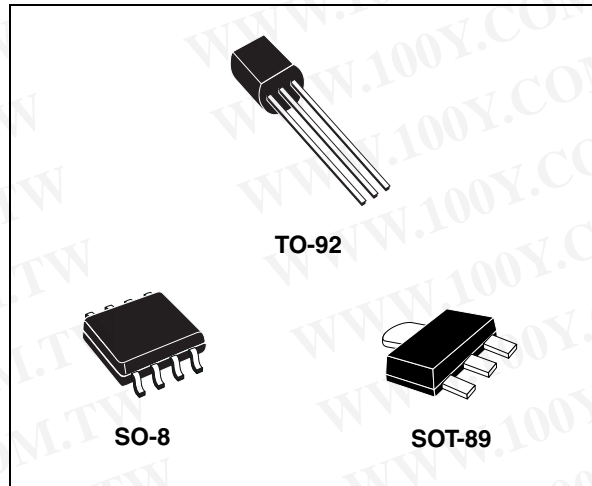

of typically two orders of magnitude, along with lower quiescent current and lower noise.

Table 1. Device summary

Part numbers		
L78L33C	L78L08AC	L78L15C
L78L33AC	L78L08AB	L78L15AC
L78L33AB	L78L09C	L78L15AB
L78L05C	L78L09AC	L78L18C
L78L05AC	L78L09AB	L78L18AC
L78L05AB	L78L10AC	L78L24C
L78L06AC	L78L12C	L78L24AC
L78L06AB	L78L12AC	L78L24AB
L78L08C	L78L12AB	

## Contents

1	Diagram .....	3
2	Pin configuration .....	4
3	Maximum ratings .....	5
4	Electrical characteristics .....	6
5	Typical performance .....	16
6	Typical application .....	18
7	Package mechanical data .....	20
8	Order codes .....	28
9	Revision history .....	32

勝特力材料 886-3-5753170  
勝特力电子(上海) 86-21-34970699  
勝特力电子(深圳) 86-755-83298787  
[Http://www.100y.com.tw](http://www.100y.com.tw)

# 1 Diagram

Figure 1. Schematic diagram

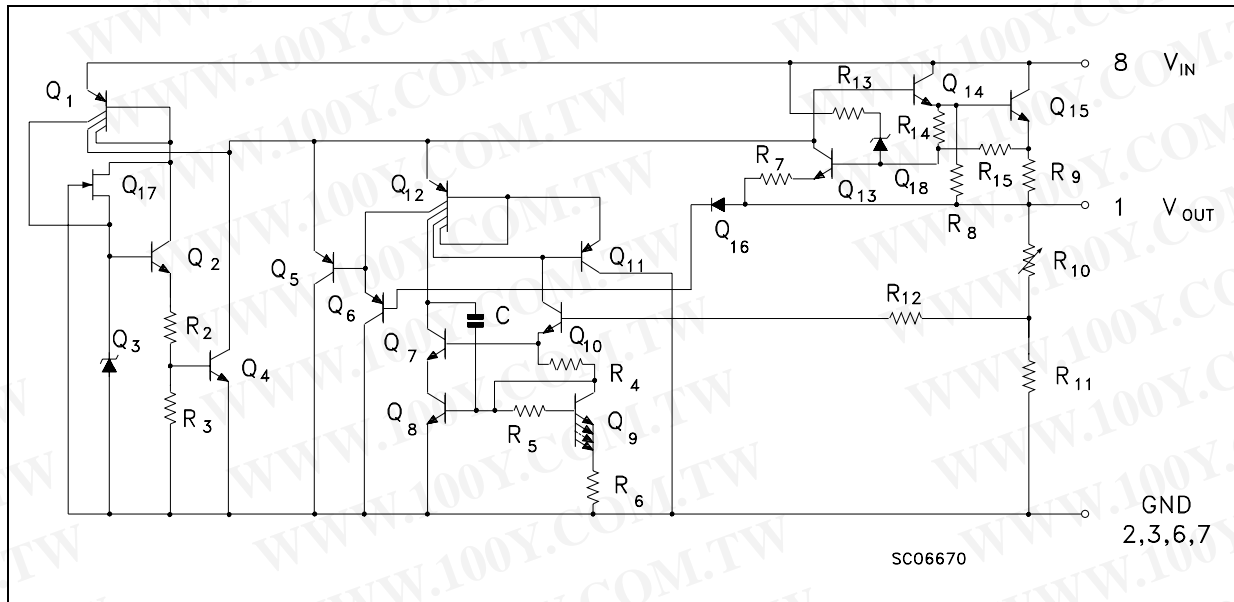

勝特力材料 886-3-5753170  
 勝特力电子(上海) 86-21-34970699  
 勝特力电子(深圳) 86-755-83298787  
[Http://www.100y.com.tw](http://www.100y.com.tw)

## 2 Pin configuration

Figure 2. Pin connection (top view, bottom view for TO-92)

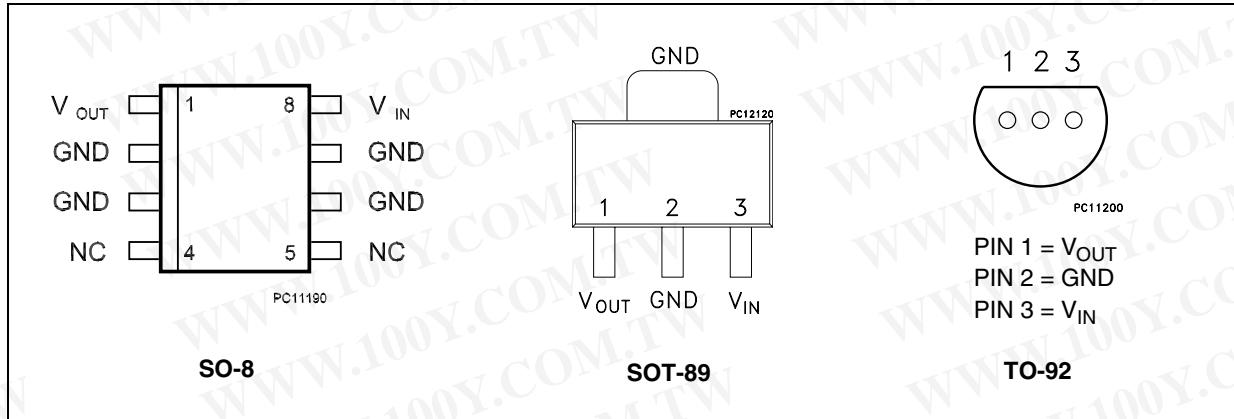
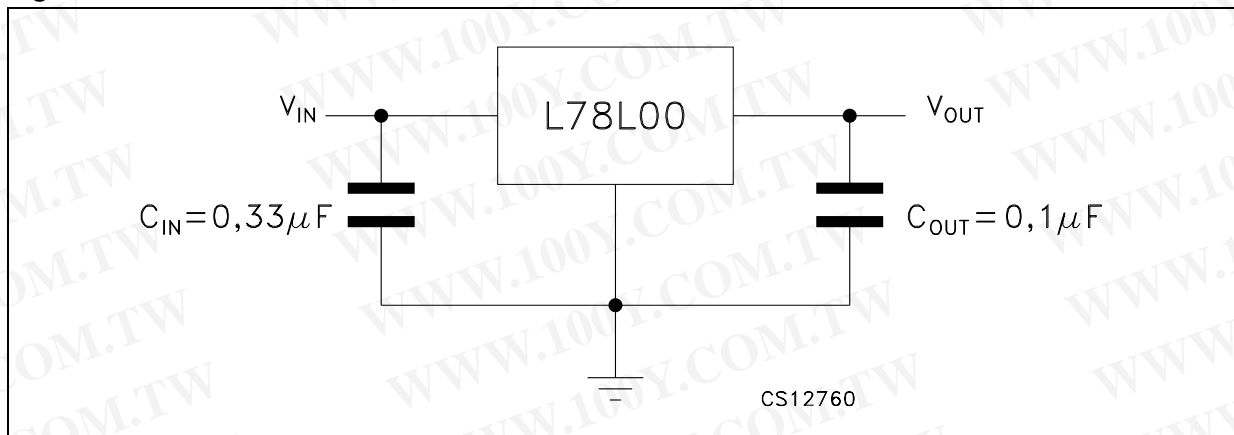

Figure 3. Test circuits



勝特力材料 886-3-5753170  
 勝特力电子(上海) 86-21-34970699  
 勝特力电子(深圳) 86-755-83298787  
[Http://www.100y.com.tw](http://www.100y.com.tw)

### 3 Maximum ratings

**Table 2. Absolute maximum ratings**

Symbol	Parameter	Value	Unit
$V_I$	DC Input voltage	$V_O = 3.3$ to 9 V	30
		$V_O = 12$ to 15 V	35
		$V_O = 18$ to 24 V	40
$I_O$	Output current	100	mA
$P_D$	Power dissipation	Internally limited <sup>(1)</sup>	mW
$T_{STG}$	Storage temperature range	-65 to 150	°C
$T_{OP}$	Operating junction temperature range	for L78L00AC	0 to 125
		for L78L00AB	-40 to 125

1. Our SO-8 package used for voltage regulators is modified internally to have pins 2, 3, 6 and 7 electrically communed to the die attach flag. This particular frame decreases the total thermal resistance of the package and increases its ability to dissipate power when an appropriate area of copper on the printed circuit board is available for heat-sinking. The external dimensions are the same as for the standard SO-8.

**Table 3. Thermal data**

Symbol	Parameter	SO-8	TO-92	SOT-89	Unit
$R_{thJC}$	Thermal resistance junction-case. (max)	20		15	°C/W
$R_{thJA}$	Thermal resistance junction-ambient. (max)	55 <sup>(1)</sup>	200	55 <sup>(1)</sup>	°C/W

1. Considering 6 cm<sup>2</sup> of copper Board heat-sink.

勝特力材料 886-3-5753170  
 勝特力电子(上海) 86-21-34970699  
 勝特力电子(深圳) 86-755-83298787  
[Http://www.100y.com.tw](http://www.100y.com.tw)

## 4 Electrical characteristics

Refer to the test circuits,  $T_J = 0$  to  $125$  °C,  $I_O = 40$  mA,  $C_I = 0.33$   $\mu$ F,  $C_O = 0.1$   $\mu$ F unless otherwise specified.

**Table 4. Electrical characteristics of L78L33C ( $V_I = 8.3$  V)**

Symbol	Parameter	Test conditions	Min.	Typ.	Max.	Unit
$V_O$	Output voltage	$T_J = 25$ °C	3.036	3.3	3.564	V
$V_O$	Output voltage	$I_O = 1$ to 40 mA, $V_I = 5.3$ to 20 V	2.97		3.63	V
		$I_O = 1$ to 70 mA, $V_I = 8.3$ V	2.97		3.63	
$\Delta V_O$	Line regulation	$V_I = 5.3$ to 20 V, $T_J = 25$ °C			150	mV
		$V_I = 6.3$ to 20 V, $T_J = 25$ °C			100	
$\Delta V_O$	Load regulation	$I_O = 1$ to 100 mA, $T_J = 25$ °C			60	mV
		$I_O = 1$ to 40 mA, $T_J = 25$ °C			30	
$I_d$	Quiescent current	$T_J = 25$ °C			6	mA
		$T_J = 125$ °C			5.5	
$\Delta I_d$	Quiescent current change	$I_O = 1$ to 40 mA			0.2	mA
		$V_I = 6.3$ to 20 V			1.5	
eN	Output noise voltage	B = 10 Hz to 100 kHz, $T_J = 25$ °C		40		$\mu$ V
SVR	Supply voltage rejection	$V_I = 6.3$ to 16.3 V, $f = 120$ Hz $I_O = 40$ mA, $T_J = 25$ °C	41	49		dB
$V_d$	Dropout voltage			1.7		V

**Table 5. Electrical characteristics of L78L05C ( $V_I = 10$  V)**

Symbol	Parameter	Test conditions	Min.	Typ.	Max.	Unit
$V_O$	Output voltage	$T_J = 25$ °C	4.6	5	5.4	V
$V_O$	Output voltage	$I_O = 1$ to 40 mA, $V_I = 7$ to 20 V	4.5		5.5	V
		$I_O = 1$ to 70 mA, $V_I = 10$ V	4.5		5.5	
$\Delta V_O$	Line regulation	$V_I = 8.5$ to 20 V, $T_J = 25$ °C			200	mV
		$V_I = 9$ to 20 V, $T_J = 25$ °C			150	
$\Delta V_O$	Load regulation	$I_O = 1$ to 100 mA, $T_J = 25$ °C			60	mV
		$I_O = 1$ to 40 mA, $T_J = 25$ °C			30	
$I_d$	Quiescent current	$T_J = 25$ °C			6	mA
		$T_J = 125$ °C			5.5	
$\Delta I_d$	Quiescent current change	$I_O = 1$ to 40 mA			0.2	mA
		$V_I = 8$ to 20 V			1.5	
eN	Output noise voltage	B = 10 Hz to 100 kHz, $T_J = 25$ °C		40		$\mu$ V

**Table 5. Electrical characteristics of L78L05C ( $V_I = 10\text{ V}$ ) (continued)**

Symbol	Parameter	Test conditions	Min.	Typ.	Max.	Unit
SVR	Supply voltage rejection	$V_I = 9\text{ to }20\text{ V}$ , $f = 120\text{ Hz}$ $I_O = 40\text{ mA}$ , $T_J = 25\text{ }^\circ\text{C}$	40	49		dB
$V_d$	Dropout voltage			1.7		V

**Table 6. Electrical characteristics of L78L08C ( $V_I = 14\text{ V}$ )**

Symbol	Parameter	Test conditions	Min.	Typ.	Max.	Unit
$V_O$	Output voltage	$T_J = 25\text{ }^\circ\text{C}$	7.36	8	8.64	V
$V_O$	Output voltage	$I_O = 1\text{ to }40\text{ mA}$ , $V_I = 8.5\text{ to }20\text{ V}$	7.2		8.8	V
		$I_O = 1\text{ to }70\text{ mA}$ , $V_I = 12\text{ V}$	7.2		8.8	
$\Delta V_O$	Line regulation	$V_I = 8.5\text{ to }20\text{ V}$ , $T_J = 25\text{ }^\circ\text{C}$			200	mV
		$V_I = 9\text{ to }20\text{ V}$ , $T_J = 25\text{ }^\circ\text{C}$			150	
$\Delta V_O$	Load regulation	$I_O = 1\text{ to }100\text{ mA}$ , $T_J = 25\text{ }^\circ\text{C}$			80	mV
		$I_O = 1\text{ to }40\text{ mA}$ , $T_J = 25\text{ }^\circ\text{C}$			40	
$I_d$	Quiescent current	$T_J = 25\text{ }^\circ\text{C}$			6	mA
		$T_J = 125\text{ }^\circ\text{C}$			5.5	mA
$\Delta I_d$	Quiescent current change	$I_O = 1\text{ to }40\text{ mA}$			0.2	mA
		$V_I = 8\text{ to }20\text{ V}$			1.5	
eN	Output noise voltage	$B = 10\text{ Hz to }100\text{ kHz}$ , $T_J = 25\text{ }^\circ\text{C}$		60		$\mu\text{V}$
SVR	Supply voltage rejection	$V_I = 9\text{ to }20\text{ V}$ , $f = 120\text{ Hz}$ $I_O = 40\text{ mA}$ , $T_J = 25\text{ }^\circ\text{C}$	36	45		dB
$V_d$	Dropout voltage			1.7		V

**Table 7. Electrical characteristics of L78L09C ( $V_I = 15\text{ V}$ )**

Symbol	Parameter	Test conditions	Min.	Typ.	Max.	Unit
$V_O$	Output voltage	$T_J = 25\text{ }^\circ\text{C}$	8.28	9	9.72	V
$V_O$	Output voltage	$I_O = 1\text{ to }40\text{ mA}$ , $V_I = 11.5\text{ to }23\text{ V}$	8.1		9.9	V
		$I_O = 1\text{ to }70\text{ mA}$ , $V_I = 15\text{ V}$	8.1		9.9	
$\Delta V_O$	Line regulation	$V_I = 11.5\text{ to }23\text{ V}$ , $T_J = 25\text{ }^\circ\text{C}$			250	mV
		$V_I = 12\text{ to }23\text{ V}$ , $T_J = 25\text{ }^\circ\text{C}$			200	
$\Delta V_O$	Load regulation	$I_O = 1\text{ to }100\text{ mA}$ , $T_J = 25\text{ }^\circ\text{C}$			80	mV
		$I_O = 1\text{ to }40\text{ mA}$ , $T_J = 25\text{ }^\circ\text{C}$			40	
$I_d$	Quiescent current	$T_J = 25\text{ }^\circ\text{C}$			6	mA
		$T_J = 125\text{ }^\circ\text{C}$			5.5	mA
$\Delta I_d$	Quiescent current change	$I_O = 1\text{ to }40\text{ mA}$			0.2	mA
		$V_I = 12\text{ to }23\text{ V}$			1.5	

Table 7. Electrical characteristics of L78L09C ( $V_I = 15\text{ V}$ ) (continued)

Symbol	Parameter	Test conditions	Min.	Typ.	Max.	Unit
eN	Output noise voltage	B = 10 Hz to 100 kHz, $T_J = 25\text{ }^\circ\text{C}$		70		$\mu\text{V}$
SVR	Supply voltage rejection	$V_I = 12\text{ to }23\text{ V}$ , $f = 120\text{ Hz}$ $I_O = 40\text{ mA}$ , $T_J = 25\text{ }^\circ\text{C}$	36	44		dB
$V_d$	Dropout voltage			1.7		V

Table 8. Electrical characteristics of L78L10C ( $V_I = 16\text{ V}$ )

Symbol	Parameter	Test conditions	Min.	Typ.	Max.	Unit
$V_O$	Output voltage	$T_J = 25\text{ }^\circ\text{C}$	9.2	10	10.8	V
$V_O$	Output voltage	$I_O = 1\text{ to }40\text{ mA}$ , $V_I = 12.5\text{ to }23\text{ V}$	9		11	V
		$I_O = 1\text{ to }70\text{ mA}$ , $V_I = 16\text{ V}$	9		11	
$\Delta V_O$	Line regulation	$V_I = 12.5\text{ to }23\text{ V}$ , $T_J = 25\text{ }^\circ\text{C}$			230	mV
		$V_I = 13\text{ to }23\text{ V}$ , $T_J = 25\text{ }^\circ\text{C}$			170	
$\Delta V_O$	Load regulation	$I_O = 1\text{ to }100\text{ mA}$ , $T_J = 25\text{ }^\circ\text{C}$			80	mV
		$I_O = 1\text{ to }40\text{ mA}$ , $T_J = 25\text{ }^\circ\text{C}$			40	
$I_d$	Quiescent current	$T_J = 25\text{ }^\circ\text{C}$			6	mA
		$T_J = 125\text{ }^\circ\text{C}$			5.5	
$\Delta I_d$	Quiescent current change	$I_O = 1\text{ to }40\text{ mA}$			0.1	mA
		$V_I = 13\text{ to }23\text{ V}$			1.5	
eN	Output noise voltage	B = 10Hz to 100kHz, $T_J = 25\text{ }^\circ\text{C}$		60		$\mu\text{V}$
SVR	Supply voltage rejection	$V_I = 14\text{ to }23\text{ V}$ , $f = 120\text{ Hz}$ $I_O = 40\text{ mA}$ , $T_J = 25\text{ }^\circ\text{C}$	37	45		dB
$V_d$	Dropout voltage			1.7		V

Table 9. Electrical characteristics of L78L12C ( $V_I = 19\text{ V}$ )

Symbol	Parameter	Test conditions	Min.	Typ.	Max.	Unit
$V_O$	Output voltage	$T_J = 25\text{ }^\circ\text{C}$	11.1	12	12.9	V
$V_O$	Output voltage	$I_O = 1\text{ to }40\text{ mA}$ , $V_I = 14.5\text{ to }27\text{ V}$	10.8		13.2	V
		$I_O = 1\text{ to }70\text{ mA}$ , $V_I = 19\text{ V}$	10.8		13.2	
$\Delta V_O$	Line regulation	$V_I = 14.5\text{ to }27\text{ V}$ , $T_J = 25\text{ }^\circ\text{C}$			250	mV
		$V_I = 16\text{ to }27\text{ V}$ , $T_J = 25\text{ }^\circ\text{C}$			200	
$\Delta V_O$	Load regulation	$I_O = 1\text{ to }100\text{ mA}$ , $T_J = 25\text{ }^\circ\text{C}$			100	mV
		$I_O = 1\text{ to }40\text{ mA}$ , $T_J = 25\text{ }^\circ\text{C}$			50	
$I_d$	Quiescent current	$T_J = 25\text{ }^\circ\text{C}$			6.5	mA
		$T_J = 125\text{ }^\circ\text{C}$			6	

Table 9. Electrical characteristics of L78L12C ( $V_I = 19\text{ V}$ ) (continued)

Symbol	Parameter	Test conditions	Min.	Typ.	Max.	Unit
$\Delta I_d$	Quiescent current change	$I_O = 1$ to 40 mA			0.2	mA
		$V_I = 16$ to 27 V			1.5	
eN	Output noise voltage	B = 10 Hz to 100 kHz, $T_J = 25\text{ }^\circ\text{C}$		80		$\mu\text{V}$
SVR	Supply voltage rejection	$V_I = 15$ to 25 V, $f = 120\text{ Hz}$ $I_O = 40\text{ mA}$ , $T_J = 25\text{ }^\circ\text{C}$	36	42		dB
$V_d$	Dropout voltage			1.7		V

Table 10. Electrical characteristics of L78L15C ( $V_I = 23\text{ V}$ )

Symbol	Parameter	Test conditions	Min.	Typ.	Max.	Unit
$V_O$	Output voltage	$T_J = 25\text{ }^\circ\text{C}$	13.8	15	16.2	V
$V_O$	Output voltage	$I_O = 1$ to 40 mA, $V_I = 17.5$ to 30 V	13.5		16.5	V
		$I_O = 1$ to 70 mA, $V_I = 23\text{ V}$	13.5		16.5	
$\Delta V_O$	Line regulation	$V_I = 17.5$ to 30 V, $T_J = 25\text{ }^\circ\text{C}$			300	mV
		$V_I = 20$ to 30 V, $T_J = 25\text{ }^\circ\text{C}$			250	
$\Delta V_O$	Load regulation	$I_O = 1$ to 100 mA, $T_J = 25\text{ }^\circ\text{C}$			150	mV
		$I_O = 1$ to 40 mA, $T_J = 25\text{ }^\circ\text{C}$			75	
$I_d$	Quiescent current	$T_J = 25\text{ }^\circ\text{C}$			6.5	mA
		$T_J = 125\text{ }^\circ\text{C}$			6	
$\Delta I_d$	Quiescent current change	$I_O = 1$ to 40 mA			0.2	mA
		$V_I = 20$ to 30 V			1.5	
eN	Output noise voltage	B = 10 Hz to 100 kHz, $T_J = 25\text{ }^\circ\text{C}$		90		$\mu\text{V}$
SVR	Supply voltage rejection	$V_I = 18.5$ to 28.5 V, $f = 120\text{ Hz}$ $I_O = 40\text{ mA}$ , $T_J = 25\text{ }^\circ\text{C}$	33	39		dB
$V_d$	Dropout voltage			1.7		V

Table 11. Electrical characteristics of L78L18C ( $V_I = 27\text{ V}$ )

Symbol	Parameter	Test conditions	Min.	Typ.	Max.	Unit
$V_O$	Output voltage	$T_J = 25\text{ }^\circ\text{C}$	16.6	18	19.4	V
$V_O$	Output voltage	$I_O = 1$ to 40 mA, $V_I = 22$ to 33 V	16.2		19.8	V
		$I_O = 1$ to 70 mA, $V_I = 27\text{ V}$	16.2		19.8	
$\Delta V_O$	Line regulation	$V_I = 22$ to 33 V, $T_J = 25\text{ }^\circ\text{C}$			320	mV
		$V_I = 22$ to 33 V, $T_J = 25\text{ }^\circ\text{C}$			270	
$\Delta V_O$	Load regulation	$I_O = 1$ to 100 mA, $T_J = 25\text{ }^\circ\text{C}$			170	mV
		$I_O = 1$ to 40 mA, $T_J = 25\text{ }^\circ\text{C}$			85	

Table 11. Electrical characteristics of L78L18C ( $V_I = 27\text{ V}$ ) (continued)

Symbol	Parameter	Test conditions	Min.	Typ.	Max.	Unit
$I_d$	Quiescent current	$T_J = 25\text{ }^\circ\text{C}$			6.5	mA
		$T_J = 125\text{ }^\circ\text{C}$			6	mA
$\Delta I_d$	Quiescent current change	$I_O = 1\text{ to }40\text{ mA}$			0.2	mA
		$V_I = 23\text{ to }33\text{ V}$			1.5	
eN	Output noise voltage	$B = 10\text{ Hz to }100\text{ kHz}, T_J = 25\text{ }^\circ\text{C}$		120		$\mu\text{V}$
SVR	Supply voltage rejection	$V_I = 23\text{ to }33\text{ V}, f = 120\text{ Hz}$ $I_O = 40\text{ mA}, T_J = 25\text{ }^\circ\text{C}$	32	38		dB
$V_d$	Dropout voltage			1.7		V

Table 12. Electrical characteristics of L78L24C ( $V_I = 33\text{ V}$ )

Symbol	Parameter	Test conditions	Min.	Typ.	Max.	Unit
$V_O$	Output voltage	$T_J = 25\text{ }^\circ\text{C}$	22.1	24	25.9	V
$V_O$	Output voltage	$I_O = 1\text{ to }40\text{ mA}, V_I = 27\text{ to }38\text{ V}$	21.6		26.4	V
		$I_O = 1\text{ to }70\text{ mA}, V_I = 33\text{ V}$	21.6		26.4	
$\Delta V_O$	Line regulation	$V_I = 27\text{ to }38\text{ V}, T_J = 25\text{ }^\circ\text{C}$			350	mV
		$V_I = 28\text{ to }38\text{ V}, T_J = 25\text{ }^\circ\text{C}$			300	
$\Delta V_O$	Load regulation	$I_O = 1\text{ to }100\text{ mA}, T_J = 25\text{ }^\circ\text{C}$			200	mV
		$I_O = 1\text{ to }40\text{ mA}, T_J = 25\text{ }^\circ\text{C}$			100	
$I_d$	Quiescent current	$T_J = 25\text{ }^\circ\text{C}$			6.5	mA
		$T_J = 125\text{ }^\circ\text{C}$			6	mA
$\Delta I_d$	Quiescent current change	$I_O = 1\text{ to }40\text{ mA}$			0.2	mA
		$V_I = 28\text{ to }38\text{ V}$			1.5	
eN	Output noise voltage	$B = 10\text{ Hz to }100\text{ kHz}, T_J = 25\text{ }^\circ\text{C}$		200		$\mu\text{V}$
SVR	Supply voltage rejection	$V_I = 29\text{ to }35\text{ V}, f = 120\text{ Hz}$ $I_O = 40\text{ mA}, T_J = 25\text{ }^\circ\text{C}$	30	37		dB
$V_d$	Dropout voltage			1.7		V

$T_J = 0\text{ to }125\text{ }^\circ\text{C}$  for L78L33AC,  $T_J = -40\text{ to }125\text{ }^\circ\text{C}$  for L78L33AB.

Table 13. Electrical characteristics of L78L33AB and L78L33AC ( $V_I = 8.3\text{ V}$ )

Symbol	Parameter	Test conditions	Min.	Typ.	Max.	Unit
$V_O$	Output voltage	$T_J = 25\text{ }^\circ\text{C}$	3.168	3.3	3.432	V
$V_O$	Output voltage	$I_O = 1\text{ to }40\text{ mA}, V_I = 5.3\text{ to }20\text{ V}$	3.135		3.465	V
		$I_O = 1\text{ to }70\text{ mA}, V_I = 8.3\text{ V}$	3.135		3.465	
$\Delta V_O$	Line regulation	$V_I = 5.3\text{ to }20\text{ V}, T_J = 25\text{ }^\circ\text{C}$			150	mV
		$V_I = 6.3\text{ to }20\text{ V}, T_J = 25\text{ }^\circ\text{C}$			100	

Table 13. Electrical characteristics of L78L33AB and L78L33AC ( $V_I = 8.3 \text{ V}$ ) (continued)

Symbol	Parameter	Test conditions	Min.	Typ.	Max.	Unit
$\Delta V_O$	Load regulation	$I_O = 1 \text{ to } 100 \text{ mA}$ , $T_J = 25 \text{ }^\circ\text{C}$			60	mV
		$I_O = 1 \text{ to } 40 \text{ mA}$ , $T_J = 25 \text{ }^\circ\text{C}$			30	
$I_d$	Quiescent current	$T_J = 25 \text{ }^\circ\text{C}$			6	mA
		$T_J = 125 \text{ }^\circ\text{C}$			5.5	mA
$\Delta I_d$	Quiescent current change	$I_O = 1 \text{ to } 40 \text{ mA}$			0.1	mA
		$V_I = 6.3 \text{ to } 20 \text{ V}$			1.5	
eN	Output noise voltage	$B = 10 \text{ Hz to } 100 \text{ kHz}$ , $T_J = 25 \text{ }^\circ\text{C}$		40		$\mu\text{V}$
SVR	Supply voltage rejection	$V_I = 6.3 \text{ to } 16.3 \text{ V}$ , $f = 120 \text{ Hz}$ $I_O = 40 \text{ mA}$ , $T_J = 25 \text{ }^\circ\text{C}$	41	49		dB
$V_d$	Dropout voltage			1.7		V

$T_J = 0 \text{ to } 125 \text{ }^\circ\text{C}$  for L78L05AC,  $T_J = -40 \text{ to } 125 \text{ }^\circ\text{C}$  for L78L05AB.

Table 14. Electrical characteristics of L78L05AB and L78L05AC ( $V_I = 10 \text{ V}$ )

Symbol	Parameter	Test conditions	Min.	Typ.	Max.	Unit
$V_O$	Output voltage	$T_J = 25 \text{ }^\circ\text{C}$	4.8	5	5.2	V
$V_O$	Output voltage	$I_O = 1 \text{ to } 40 \text{ mA}$ , $V_I = 7 \text{ to } 20 \text{ V}$	4.75		5.25	V
		$I_O = 1 \text{ to } 70 \text{ mA}$ , $V_I = 10 \text{ V}$	4.75		5.25	
$\Delta V_O$	Line regulation	$V_I = 7 \text{ to } 20 \text{ V}$ , $T_J = 25 \text{ }^\circ\text{C}$			150	mV
		$V_I = 8 \text{ to } 20 \text{ V}$ , $T_J = 25 \text{ }^\circ\text{C}$			100	
$\Delta V_O$	Load regulation	$I_O = 1 \text{ to } 100 \text{ mA}$ , $T_J = 25 \text{ }^\circ\text{C}$			60	mV
		$I_O = 1 \text{ to } 40 \text{ mA}$ , $T_J = 25 \text{ }^\circ\text{C}$			30	
$I_d$	Quiescent current	$T_J = 25 \text{ }^\circ\text{C}$			6	mA
		$T_J = 125 \text{ }^\circ\text{C}$			5.5	mA
$\Delta I_d$	Quiescent current change	$I_O = 1 \text{ to } 40 \text{ mA}$			0.1	mA
		$V_I = 8 \text{ to } 20 \text{ V}$			1.5	
eN	Output noise voltage	$B = 10 \text{ Hz to } 100 \text{ kHz}$ , $T_J = 25 \text{ }^\circ\text{C}$		40		$\mu\text{V}$
SVR	Supply voltage rejection	$V_I = 8 \text{ to } 18 \text{ V}$ , $f = 120 \text{ Hz}$ $I_O = 40 \text{ mA}$ , $T_J = 25 \text{ }^\circ\text{C}$	41	49		dB
$V_d$	Dropout voltage			1.7		V

$T_J = 0 \text{ to } 125 \text{ }^\circ\text{C}$  for L78L06AC,  $T_J = -40 \text{ to } 125 \text{ }^\circ\text{C}$  for L78L06AB.

Table 15. Electrical characteristics of L78L06AB and L78L06AC ( $V_I = 12\text{ V}$ )

Symbol	Parameter	Test conditions	Min.	Typ.	Max.	Unit
$V_O$	Output voltage	$T_J = 25\text{ }^\circ\text{C}$	5.76	6	6.24	V
$V_O$	Output voltage	$I_O = 1\text{ to }40\text{ mA}, V_I = 8.5\text{ to }20\text{ V}$	5.7		6.3	V
		$I_O = 1\text{ to }70\text{ mA}, V_I = 12\text{ V}$	5.7		6.3	
$\Delta V_O$	Line regulation	$V_I = 8.5\text{ to }20\text{ V}, T_J = 25\text{ }^\circ\text{C}$			150	mV
		$V_I = 9\text{ to }20\text{ V}, T_J = 25\text{ }^\circ\text{C}$			100	
$\Delta V_O$	Load regulation	$I_O = 1\text{ to }100\text{ mA}, T_J = 25\text{ }^\circ\text{C}$			60	mV
		$I_O = 1\text{ to }40\text{ mA}, T_J = 25\text{ }^\circ\text{C}$			30	
$I_d$	Quiescent current	$T_J = 25\text{ }^\circ\text{C}$			6	mA
		$T_J = 125\text{ }^\circ\text{C}$			5.5	mA
$\Delta I_d$	Quiescent current change	$I_O = 1\text{ to }40\text{ mA}$			0.1	mA
		$V_I = 9\text{ to }20\text{ V}$			1.5	
eN	Output noise voltage	$B = 10\text{ Hz to }100\text{ kHz}, T_J = 25\text{ }^\circ\text{C}$		50		$\mu\text{V}$
SVR	Supply voltage rejection	$V_I = 9\text{ to }20\text{ V}, f = 120\text{ Hz}$ $I_O = 40\text{ mA}, T_J = 25\text{ }^\circ\text{C}$	39	46		dB
$V_d$	Dropout voltage			1.7		V

$T_J = 0\text{ to }125\text{ }^\circ\text{C}$  for L78L08AC,  $T_J = -40\text{ to }125\text{ }^\circ\text{C}$  for L78L08AB.

Table 16. Electrical characteristics of L78L08AB and L78L08AC ( $V_I = 14\text{ V}$ )

Symbol	Parameter	Test conditions	Min.	Typ.	Max.	Unit
$V_O$	Output voltage	$T_J = 25\text{ }^\circ\text{C}$	7.68	8	8.32	V
$V_O$	Output voltage	$I_O = 1\text{ to }40\text{ mA}, V_I = 10.5\text{ to }23\text{ V}$	7.6		8.4	V
		$I_O = 1\text{ to }70\text{ mA}, V_I = 14\text{ V}$	7.6		8.4	
$\Delta V_O$	Line regulation	$V_I = 10.5\text{ to }23\text{ V}, T_J = 25\text{ }^\circ\text{C}$			175	mV
		$V_I = 11\text{ to }23\text{ V}, T_J = 25\text{ }^\circ\text{C}$			125	
$\Delta V_O$	Load regulation	$I_O = 1\text{ to }100\text{ mA}, T_J = 25\text{ }^\circ\text{C}$			80	mV
		$I_O = 1\text{ to }40\text{ mA}, T_J = 25\text{ }^\circ\text{C}$			40	
$I_d$	Quiescent current	$T_J = 25\text{ }^\circ\text{C}$			6	mA
		$T_J = 125\text{ }^\circ\text{C}$			5.5	mA
$\Delta I_d$	Quiescent current change	$I_O = 1\text{ to }40\text{ mA}$			0.1	mA
		$V_I = 11\text{ to }23\text{ V}$			1.5	
eN	Output noise voltage	$B = 10\text{ Hz to }100\text{ kHz}, T_J = 25\text{ }^\circ\text{C}$		60		$\mu\text{V}$
SVR	Supply voltage rejection	$V_I = 12\text{ to }23\text{ V}, f = 120\text{ Hz}$ $I_O = 40\text{ mA}, T_J = 25\text{ }^\circ\text{C}$	37	45		dB
$V_d$	Dropout voltage			1.7		V

$T_J = 0$  to  $125$  °C for L78L09AC,  $T_J = -40$  to  $125$  °C for L78L09AB.

**Table 17. Electrical characteristics of L78L09AB and L78L09AC ( $V_I = 15$  V)**

Symbol	Parameter	Test conditions	Min.	Typ.	Max.	Unit
$V_O$	Output voltage	$T_J = 25$ °C	8.64	9	9.36	V
$V_O$	Output voltage	$I_O = 1$ to $40$ mA, $V_I = 11.5$ to $23$ V	8.55		9.45	V
		$I_O = 1$ to $70$ mA, $V_I = 15$ V	8.55		9.45	
$\Delta V_O$	Line regulation	$V_I = 11.5$ to $23$ V, $T_J = 25$ °C			225	mV
		$V_I = 12$ to $23$ V, $T_J = 25$ °C			150	
$\Delta V_O$	Load regulation	$I_O = 1$ to $100$ mA, $T_J = 25$ °C			80	mV
		$I_O = 1$ to $40$ mA, $T_J = 25$ °C			40	
$I_d$	Quiescent current	$T_J = 25$ °C			6	mA
		$T_J = 125$ °C			5.5	mA
$\Delta I_d$	Quiescent current change	$I_O = 1$ to $40$ mA			0.1	mA
		$V_I = 12$ to $23$ V			1.5	
eN	Output noise voltage	$B = 10$ Hz to $100$ kHz, $T_J = 25$ °C		70		$\mu$ V
SVR	Supply voltage rejection	$V_I = 12$ to $23$ V, $f = 120$ Hz $I_O = 40$ mA, $T_J = 25$ °C	37	44		dB
$V_d$	Dropout voltage			1.7		V

$T_J = 0$  to  $125$  °C for L78L10AC,  $T_J = -40$  to  $125$  °C for L78L10AB.

**Table 18. Electrical characteristics of L78L10AC ( $V_I = 16$  V)**

Symbol	Parameter	Test conditions	Min.	Typ.	Max.	Unit
$V_O$	Output voltage	$T_J = 25$ °C	9.6	10	10.4	V
$V_O$	Output voltage	$I_O = 1$ to $40$ mA, $V_I = 12.5$ to $23$ V	9.5		10.5	V
		$I_O = 1$ to $70$ mA, $V_I = 16$ V	9.5		10.5	
$\Delta V_O$	Line regulation	$V_I = 12.5$ to $23$ V, $T_J = 25$ °C			230	mV
		$V_I = 13$ to $23$ V, $T_J = 25$ °C			170	
$\Delta V_O$	Load regulation	$I_O = 1$ to $100$ mA, $T_J = 25$ °C			80	mV
		$I_O = 1$ to $40$ mA, $T_J = 25$ °C			40	
$I_d$	Quiescent current	$T_J = 25$ °C			6	mA
		$T_J = 125$ °C			5.5	mA
$\Delta I_d$	Quiescent current change	$I_O = 1$ to $40$ mA			0.1	mA
		$V_I = 13$ to $23$ V			1.5	
eN	Output noise voltage	$B = 10$ Hz to $100$ kHz, $T_J = 25$ °C		60		$\mu$ V
SVR	Supply voltage rejection	$V_I = 14$ to $23$ V, $f = 120$ Hz $I_O = 40$ mA, $T_J = 25$ °C	37	45		dB
$V_d$	Dropout voltage			1.7		V

$T_J = 0$  to  $125\text{ }^\circ\text{C}$  for L78L12AC,  $T_J = -40$  to  $125\text{ }^\circ\text{C}$  for L78L12AB.

**Table 19. Electrical characteristics of L78L12AB and L78L12AC ( $V_I = 19\text{ V}$ )**

Symbol	Parameter	Test conditions	Min.	Typ.	Max.	Unit
$V_O$	Output voltage	$T_J = 25\text{ }^\circ\text{C}$	11.5	12	12.5	V
$V_O$	Output voltage	$I_O = 1$ to $40\text{ mA}$ , $V_I = 14.5$ to $27\text{ V}$	11.4		12.6	V
		$I_O = 1$ to $70\text{ mA}$ , $V_I = 19\text{ V}$	11.4		12.6	
$\Delta V_O$	Line regulation	$V_I = 14.5$ to $27\text{ V}$ , $T_J = 25\text{ }^\circ\text{C}$			250	mV
		$V_I = 16$ to $27\text{ V}$ , $T_J = 25\text{ }^\circ\text{C}$			200	
$\Delta V_O$	Load regulation	$I_O = 1$ to $100\text{ mA}$ , $T_J = 25\text{ }^\circ\text{C}$			100	mV
		$I_O = 1$ to $40\text{ mA}$ , $T_J = 25\text{ }^\circ\text{C}$			50	
$I_d$	Quiescent current	$T_J = 25\text{ }^\circ\text{C}$			6.5	mA
		$T_J = 125\text{ }^\circ\text{C}$			6	mA
$\Delta I_d$	Quiescent current change	$I_O = 1$ to $40\text{ mA}$			0.1	mA
		$V_I = 16$ to $27\text{ V}$			1.5	
eN	Output noise voltage	$B = 10\text{ Hz}$ to $100\text{ kHz}$ , $T_J = 25\text{ }^\circ\text{C}$		80		$\mu\text{V}$
SVR	Supply voltage rejection	$V_I = 15$ to $25\text{ V}$ , $f = 120\text{ Hz}$ $I_O = 40\text{ mA}$ , $T_J = 25\text{ }^\circ\text{C}$	37	42		dB
$V_d$	Dropout voltage			1.7		V

$T_J = 0$  to  $125\text{ }^\circ\text{C}$  for L78L15AC,  $T_J = -40$  to  $125\text{ }^\circ\text{C}$  for L78L15AB.

**Table 20. Electrical characteristics of L78L15AB and L78L15AC ( $V_I = 23\text{ V}$ )**

Symbol	Parameter	Test conditions	Min.	Typ.	Max.	Unit
$V_O$	Output voltage	$T_J = 25\text{ }^\circ\text{C}$	14.4	15	15.6	V
$V_O$	Output voltage	$I_O = 1$ to $40\text{ mA}$ , $V_I = 17.5$ to $30\text{ V}$	14.25		15.75	V
		$I_O = 1$ to $70\text{ mA}$ , $V_I = 23\text{ V}$	14.25		15.75	
$\Delta V_O$	Line regulation	$V_I = 17.5$ to $30\text{ V}$ , $T_J = 25\text{ }^\circ\text{C}$			300	mV
		$V_I = 20$ to $30\text{ V}$ , $T_J = 25\text{ }^\circ\text{C}$			250	
$\Delta V_O$	Load regulation	$I_O = 1$ to $100\text{ mA}$ , $T_J = 25\text{ }^\circ\text{C}$			150	mV
		$I_O = 1$ to $40\text{ mA}$ , $T_J = 25\text{ }^\circ\text{C}$			75	
$I_d$	Quiescent current	$T_J = 25\text{ }^\circ\text{C}$			6.5	mA
		$T_J = 125\text{ }^\circ\text{C}$			6	mA
$\Delta I_d$	Quiescent current change	$I_O = 1$ to $40\text{ mA}$			0.1	mA
		$V_I = 20$ to $30\text{ V}$			1.5	
eN	Output noise voltage	$B = 10\text{ Hz}$ to $100\text{ kHz}$ , $T_J = 25\text{ }^\circ\text{C}$		90		$\mu\text{V}$
SVR	Supply voltage rejection	$V_I = 18.5$ to $28.5\text{ V}$ , $f = 120\text{ Hz}$ $I_O = 40\text{ mA}$ , $T_J = 25\text{ }^\circ\text{C}$	34	39		dB
$V_d$	Dropout voltage			1.7		V



$T_J = 0$  to  $125$  °C for L78L18AC,  $T_J = -40$  to  $125$  °C for L78L18AB.

**Table 21. Electrical characteristics of L78L18AC ( $V_I = 27$  V)**

Symbol	Parameter	Test conditions	Min.	Typ.	Max.	Unit
$V_O$	Output voltage	$T_J = 25$ °C	17.3	18	18.7	V
$V_O$	Output voltage	$I_O = 1$ to 40 mA, $V_I = 22$ to 33 V	17.1		18.9	V
		$I_O = 1$ to 70 mA, $V_I = 27$ V	17.1		18.9	
$\Delta V_O$	Line regulation	$V_I = 22$ to 33 V, $T_J = 25$ °C			320	mV
		$V_I = 22$ to 33 V, $T_J = 25$ °C			270	
$\Delta V_O$	Load regulation	$I_O = 1$ to 100 mA, $T_J = 25$ °C			170	mV
		$I_O = 1$ to 40 mA, $T_J = 25$ °C			85	
$I_d$	Quiescent current	$T_J = 25$ °C			6.5	mA
		$T_J = 125$ °C			6	mA
$\Delta I_d$	Quiescent current change	$I_O = 1$ to 40 mA			0.1	mA
		$V_I = 23$ to 33 V			1.5	
eN	Output noise voltage	B = 10 Hz to 100 kHz, $T_J = 25$ °C		120		$\mu$ V
SVR	Supply voltage rejection	$V_I = 23$ to 33 V, $f = 120$ Hz $I_O = 40$ mA, $T_J = 25$ °C	33	38		dB
$V_d$	Dropout voltage			1.7		V

$T_J = 0$  to  $125$  °C for L78L24AC,  $T_J = -40$  to  $125$  °C for L78L24AB.

**Table 22. Electrical characteristics of L78L24AB and L78L24AC ( $V_I = 33$  V)**

Symbol	Parameter	Test conditions	Min.	Typ.	Max.	Unit
$V_O$	Output voltage	$T_J = 25$ °C	23	24	25	V
$V_O$	Output voltage	$I_O = 1$ to 40 mA, $V_I = 27$ to 38 V	22.8		25.2	V
		$I_O = 1$ to 70 mA, $V_I = 33$ V	22.8		25.2	
$\Delta V_O$	Line regulation	$V_I = 27$ to 38 V, $T_J = 25$ °C			350	mV
		$V_I = 28$ to 38 V, $T_J = 25$ °C			300	
$\Delta V_O$	Load regulation	$I_O = 1$ to 100 mA, $T_J = 25$ °C			200	mV
		$I_O = 1$ to 40 mA, $T_J = 25$ °C			100	
$I_d$	Quiescent current	$T_J = 25$ °C			6.5	mA
		$T_J = 125$ °C			6	mA
$\Delta I_d$	Quiescent current change	$I_O = 1$ to 40 mA			0.1	mA
		$V_I = 28$ to 38 V			1.5	
eN	Output noise voltage	B = 10 Hz to 100 kHz, $T_J = 25$ °C		200		$\mu$ V
SVR	Supply voltage rejection	$V_I = 29$ to 33 V, $f = 120$ Hz $I_O = 40$ mA, $T_J = 25$ °C	31	37		dB
$V_d$	Dropout voltage			1.7		V

## 5 Typical performance

Figure 4. L78L05/12 output voltage vs. ambient temperature

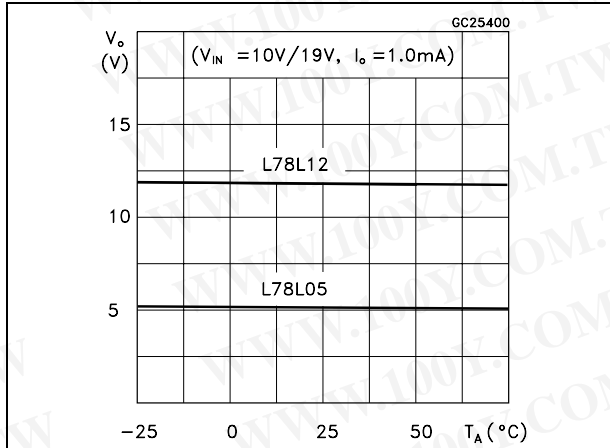

Figure 5. L78L05/12/24 load characteristics

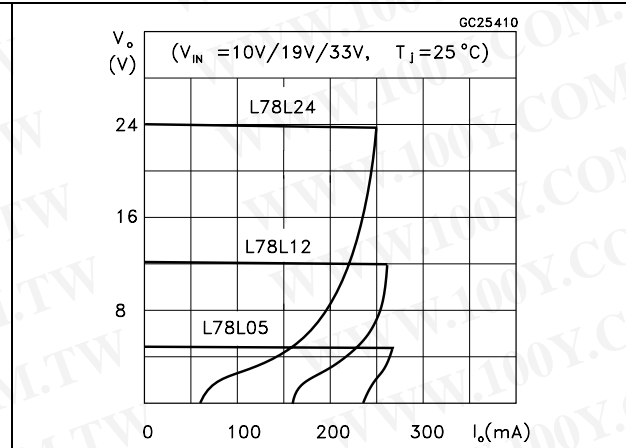

Figure 6. L78L05/12/24 thermal shutdown

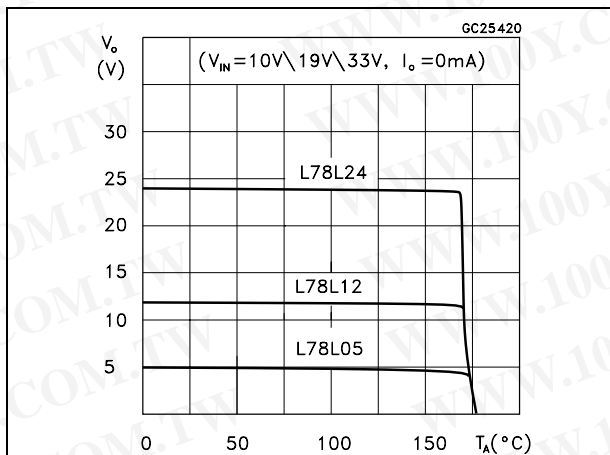
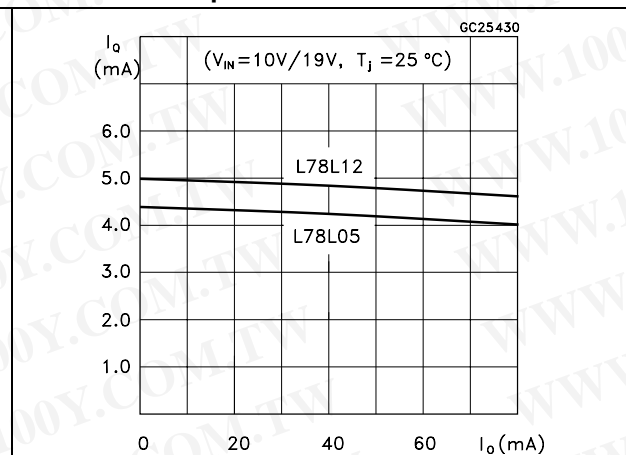

Figure 7. L78L05/12 quiescent current vs. output current



勝特力材料 886-3-5753170  
 勝特力电子(上海) 86-21-34970699  
 勝特力电子(深圳) 86-755-83298787  
[Http://www.100y.com.tw](http://www.100y.com.tw)

Figure 8. L78L05 quiescent current vs. input voltage

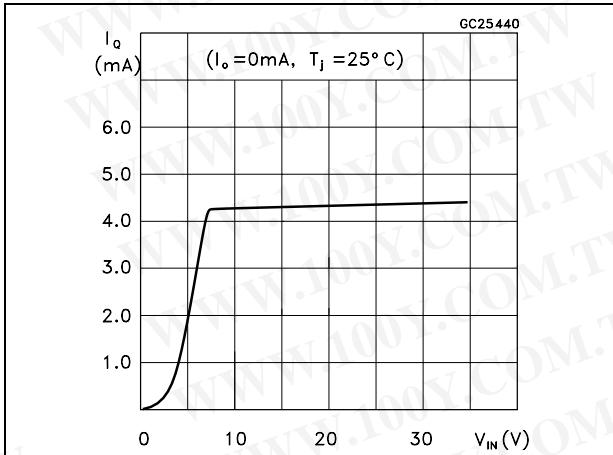

Figure 9. L78L05/12/24 output characteristics

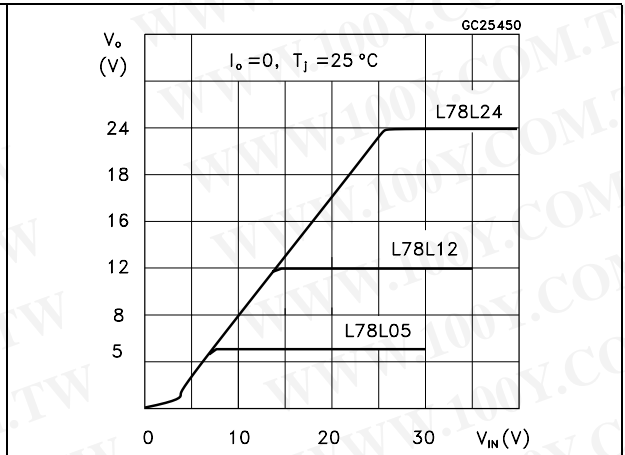

Figure 10. L78L05/12/24 ripple rejection

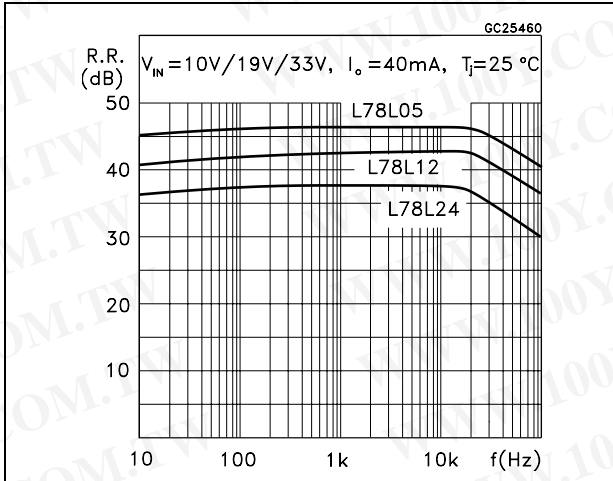

Figure 11. L78L05 dropout characteristics

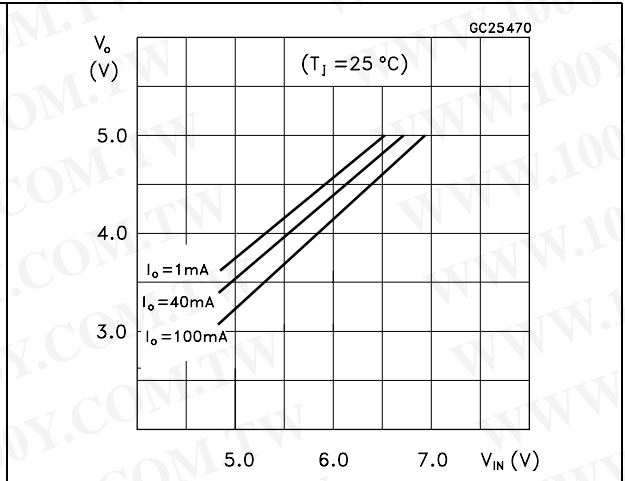
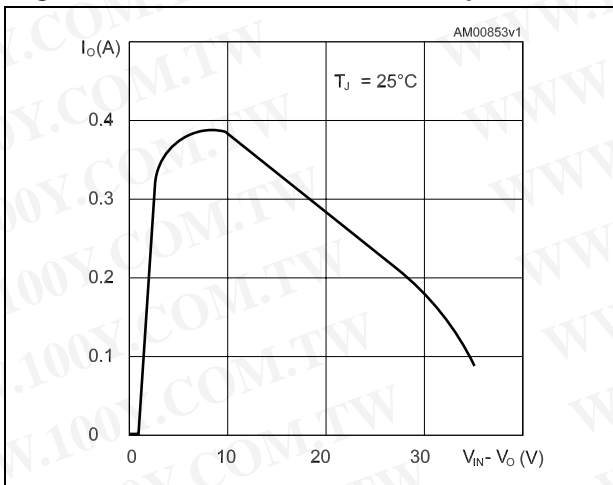

Figure 12. L78Lxx short-circuit output current



勝特力材料 886-3-5753170  
 勝特力电子(上海) 86-21-34970699  
 勝特力电子(深圳) 86-755-83298787  
[Http://www.100y.com.tw](http://www.100y.com.tw)

## 6 Typical application

Figure 13. High output current short-circuit protected

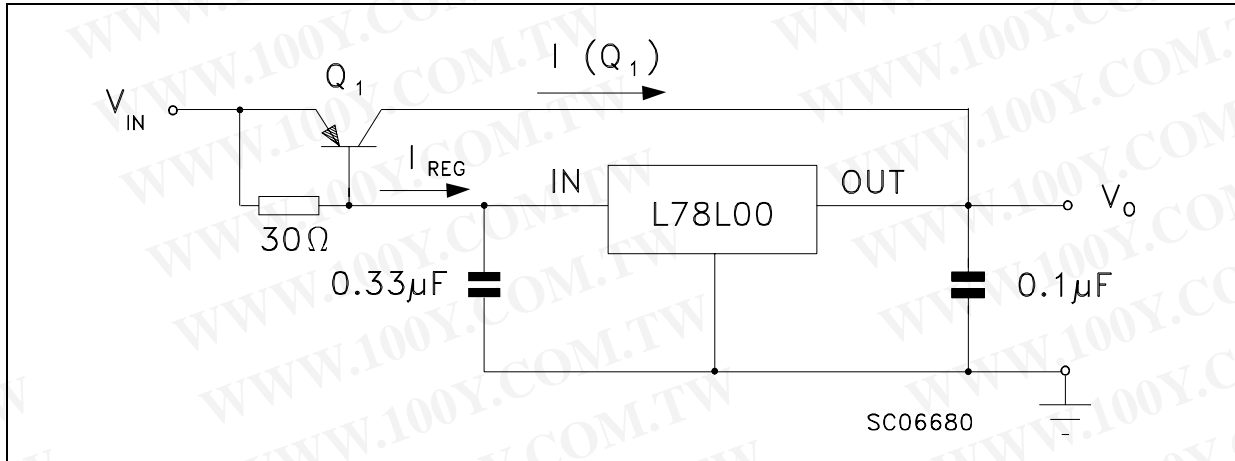

Figure 14. Edit boost circuit

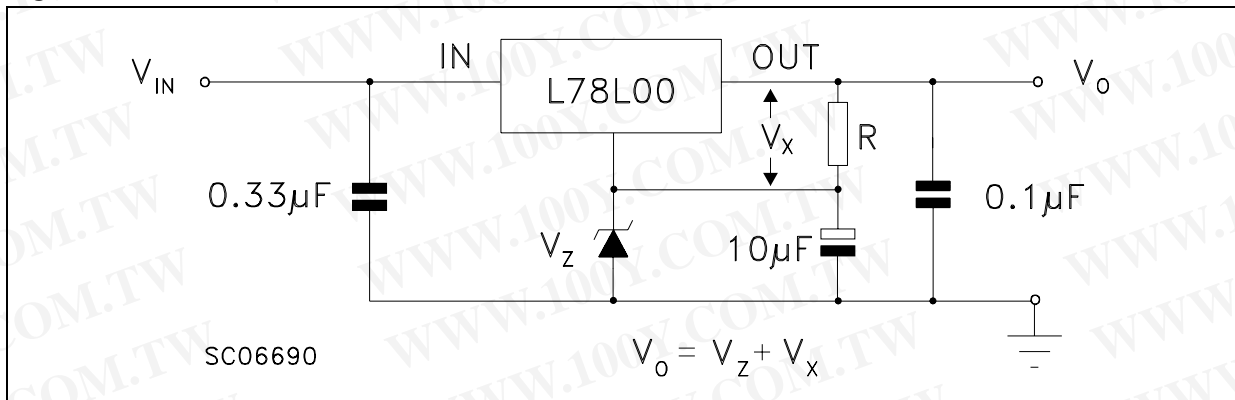

Figure 15. Current regulator

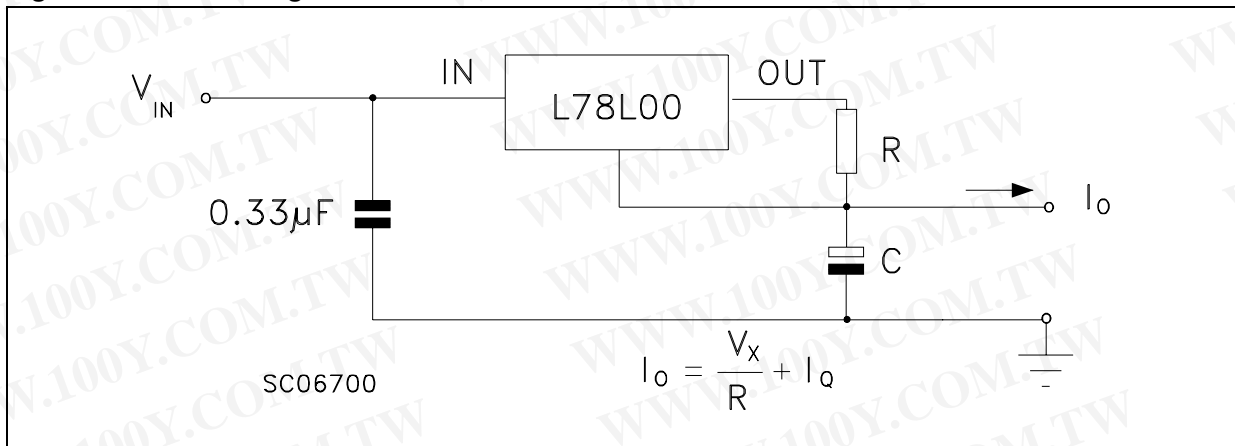
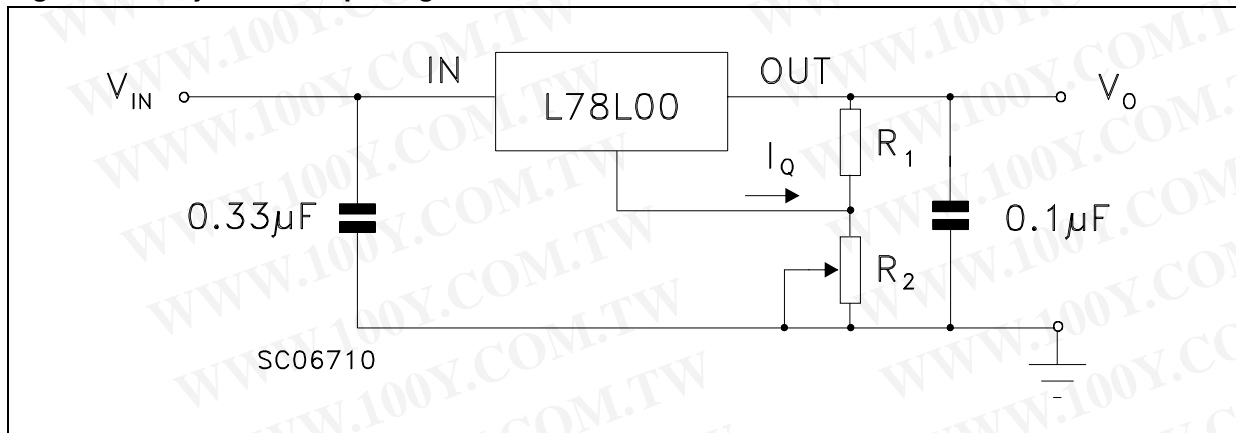

Figure 16. Adjustable output regulator



勝特力材料 886-3-5753170  
勝特力电子(上海) 86-21-34970699  
勝特力电子(深圳) 86-755-83298787  
[Http://www.100y.com.tw](http://www.100y.com.tw)

## 7 Package mechanical data

In order to meet environmental requirements, ST offers these devices in different grades of ECOPACK® packages, depending on their level of environmental compliance. ECOPACK® specifications, grade definitions and product status are available at: [www.st.com](http://www.st.com). ECOPACK® is an ST trademark.

勝特力材料 886-3-5753170  
勝特力电子(上海) 86-21-34970699  
勝特力电子(深圳) 86-755-83298787  
[Http://www.100y.com.tw](http://www.100y.com.tw)

**SO-8 mechanical data**

Dim.	mm.			inch.		
	Min.	Typ.	Max.	Min.	Typ.	Max.
A	1.35		1.75	0.053		0.069
A1	0.10		0.25	0.04		0.010
A2	1.10		1.65	0.043		0.065
B	0.33		0.51	0.013		0.020
C	0.19		0.25	0.007		0.010
D	4.80		5.00	0.189		0.197
E	3.80		4.00	0.150		0.157
e		1.27			0.050	
H	5.80		6.20	0.228		0.244
h	0.25		0.50	0.010		0.020
L	0.40		1.27	0.016		0.050
k	8° (max.)					
ddd			0.1			0.04

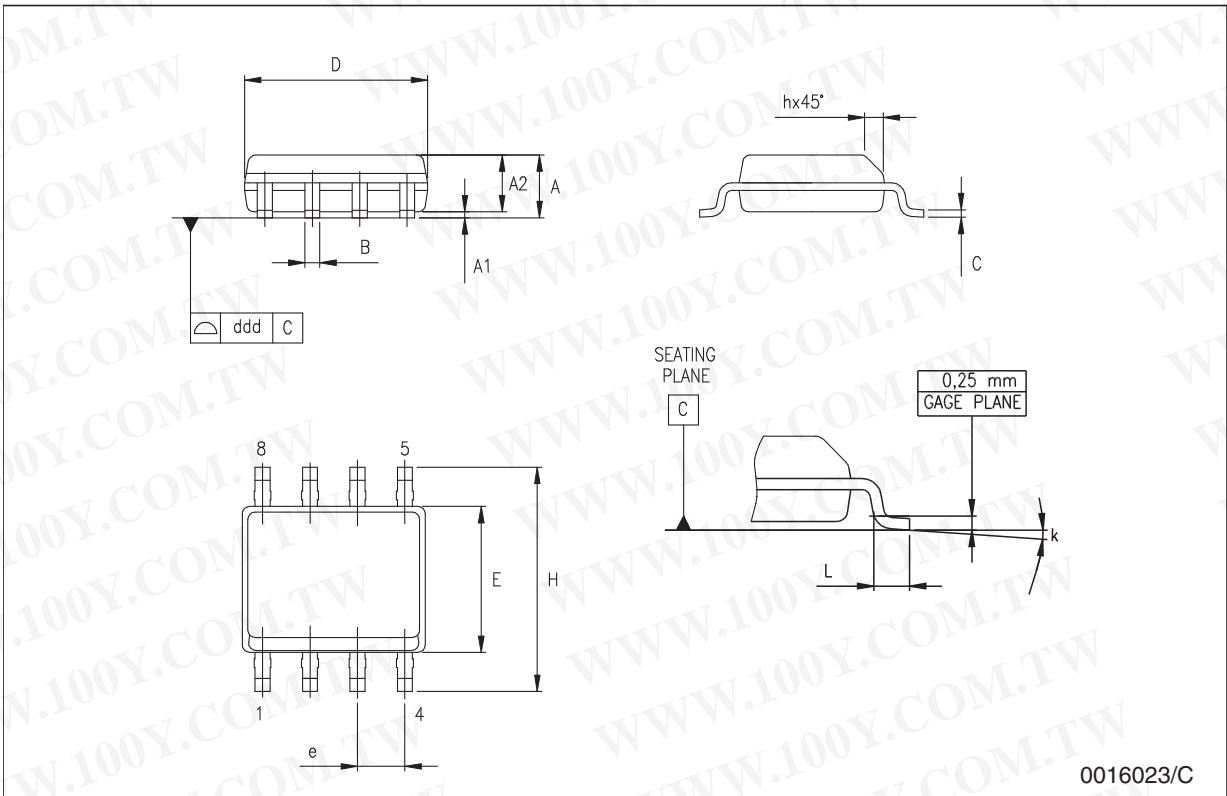

0016023/C



勝特力材料 886-3-5753170  
 勝特力电子(上海) 86-21-34970699  
 勝特力电子(深圳) 86-755-83298787  
[Http://www.100y.com.tw](http://www.100y.com.tw)

**SOT-89 mechanical data**

Dim.	mm.			mils.		
	Min.	Typ.	Max.	Min.	Typ.	Max.
A	1.4		1.6	55.1		63.0
B	0.44		0.56	17.3		22.0
B1	0.36		0.48	14.2		18.9
C	0.35		0.44	13.8		17.3
C1	0.35		0.44	13.8		17.3
D	4.4		4.6	173.2		181.1
D1	1.62		1.83	63.8		72.0
E	2.29		2.6	90.2		102.4
e	1.42		1.57	55.9		61.8
e1	2.92		3.07	115.0		120.9
H	3.94		4.25	155.1		167.3
L	0.89		1.2	35.0		47.2

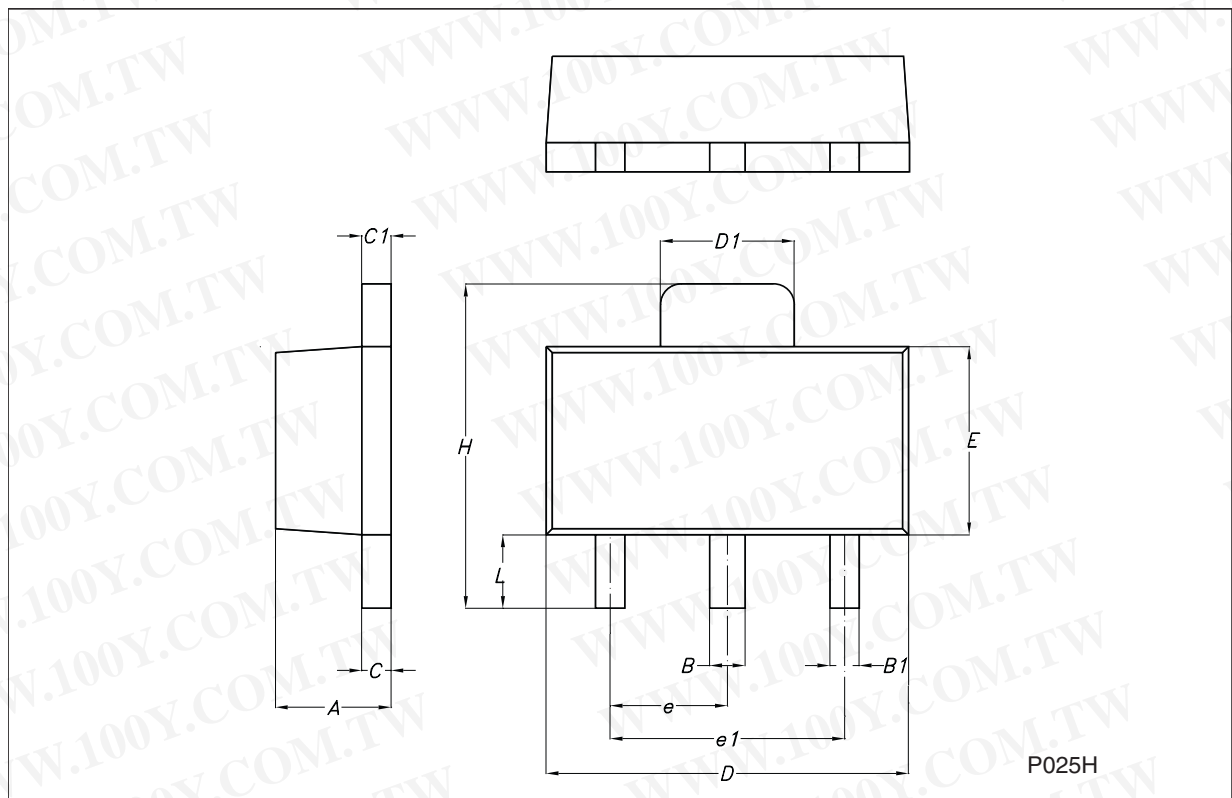

勝特力材料 886-3-5753170  
 勝特力电子(上海) 86-21-34970699  
 勝特力电子(深圳) 86-755-83298787  
[Http://www.100y.com.tw](http://www.100y.com.tw)

## TO-92 mechanical data

Dim.	mm.			mils.		
	Min.	Typ.	Max.	Min.	Typ.	Max.
A	4.32		4.95	170.1		194.9
b	0.36		0.51	14.2		20.1
D	4.45		4.95	175.2		194.9
E	3.30		3.94	129.9		155.1
e	2.41		2.67	94.9		105.1
e1	1.14		1.40	44.9		55.1
L	12.7		15.49	500.0		609.8
R	2.16		2.41	85.0		94.9
S1	0.92		1.52	36.2		59.8
W	0.41		0.56	16.1		22.0
$\alpha$		5°			5°	

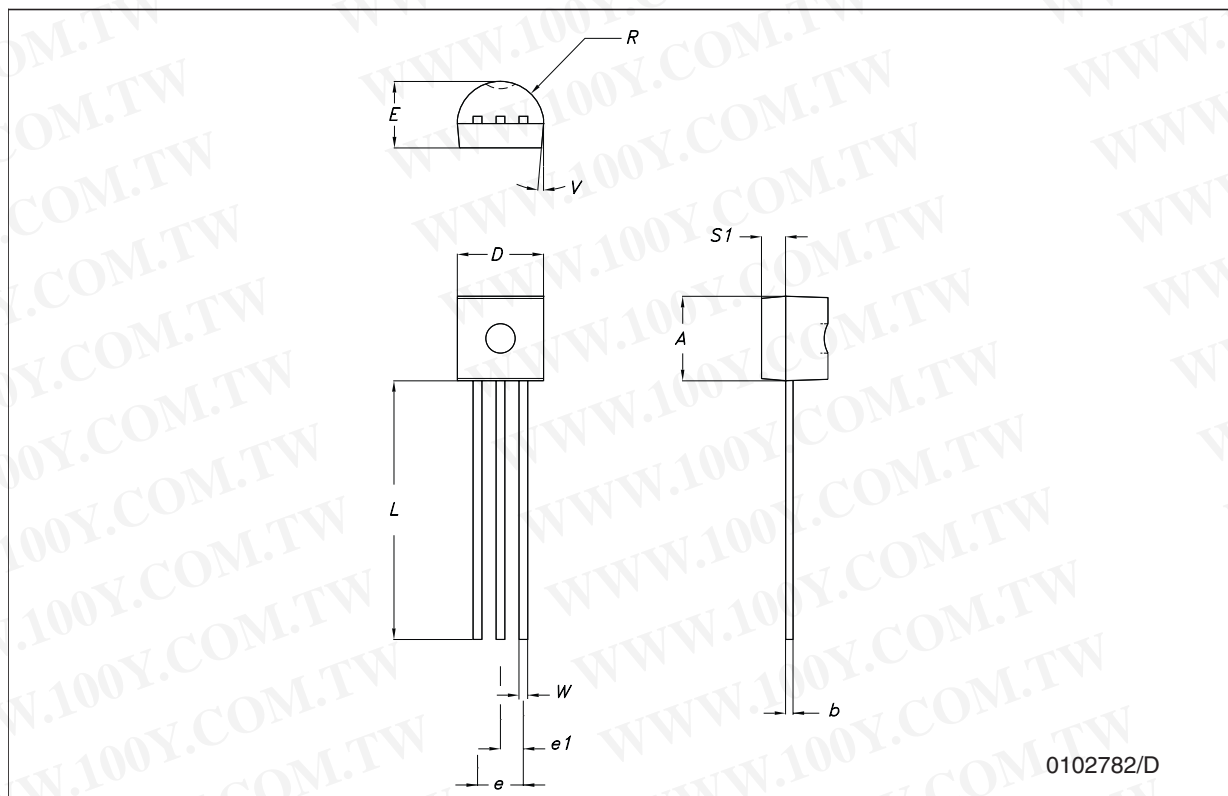

**Tape & reel SO-8 mechanical data**

Dim.	mm.			inch.		
	Min.	Typ.	Max.	Min.	Typ.	Max.
A			330			12.992
C	12.8		13.2	0.504		0.519
D	20.2			0.795		
N	60			2.362		
T			22.4			0.882
Ao	8.1		8.5	0.319		0.335
Bo	5.5		5.9	0.216		0.232
Ko	2.1		2.3	0.082		0.090
Po	3.9		4.1	0.153		0.161
P	7.9		8.1	0.311		0.319

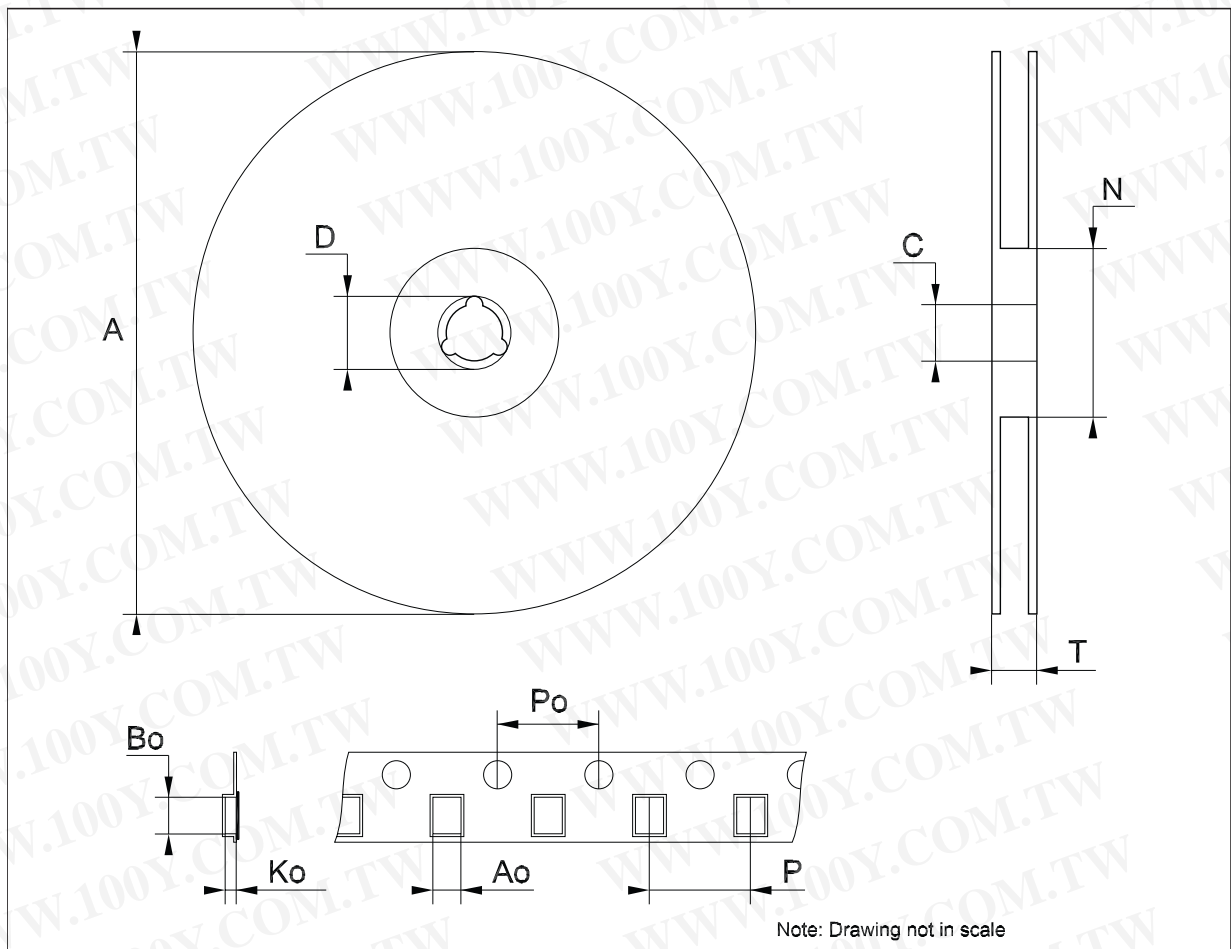

**Tape & reel SOT-89 mechanical data**

Dim.	mm.			inch.		
	Min.	Typ.	Max.	Min.	Typ.	Max.
A			180			7.086
C	12.8	13.0	13.2	0.504	0.512	0.519
D	20.2			0.795		
N	60			2.362		
T			14.4			0.567
Ao	4.70	4.80	4.90	0.185	0.189	0.193
Bo	4.30	4.40	4.50	0.169	0.173	0.177
Ko	1.70	1.80	1.90	0.067	0.071	0.075
Po	3.9	4.0	4.1	0.153	0.157	0.161
P	7.9	8.0	8.1	0.311	0.315	0.319

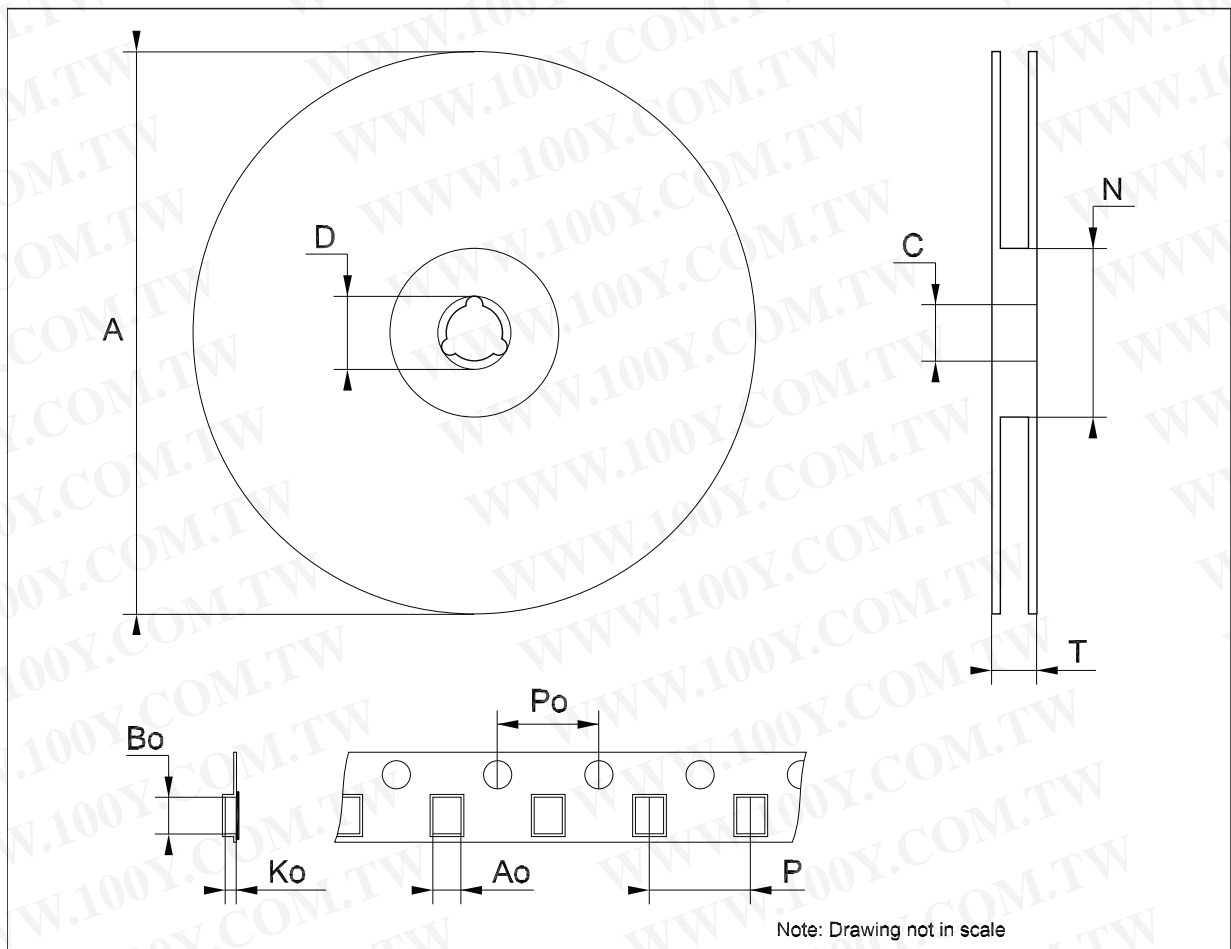

勝特力材料 886-3-5753170  
 勝特力电子(上海) 86-21-34970699  
 勝特力电子(深圳) 86-755-83298787  
[Http://www.100y.com.tw](http://www.100y.com.tw)

Table 23. Tape and reel TO-92 mechanical data

Dim.	mm.			inch.		
	Min.	Typ.	Max.	Min.	Typ.	Max.
A1 (1)		4.80			0.189	
T (1)		3.80			0.150	
T1		1.60			0.063	
T2		2.30			0.091	
d		0.48			0.019	
P0	12.5		12.9	0.492		0.508
P2	5.65		7.05	0.222		0.278
F1, F2	2.44	2.54	2.94	0.096	0.100	0.116
delta H		±2			0.079	
W	17.5	18.00	19.0	0.689	0.709	0.748
W0	5.7		6.3	0.224		0.248
W1	8.5		9.25	0.335		0.364
W2		0.50			0.20	
H		18.50	18.70		0.728	0.726
H0	15.50		16.50	0.610		0.650
H1		25.00			0.984	
D0	3.8		4.2	0.150		0.165
t		0.90			0.035	
L1		3			0.118	
delta P		±1			0.039	
u		50			1.968	
Φ1		360			14.173	
Φ2		30			1.181	

1. For the MAX and MIN values refer to the TO-92 mechanical data [on page 23](#).

勝特力材料 886-3-5753170  
 勝特力电子(上海) 86-21-34970699  
 勝特力电子(深圳) 86-755-83298787  
[Http://www.100y.com.tw](http://www.100y.com.tw)



Figure 17. Tape and reel TO-92 drawing dimension

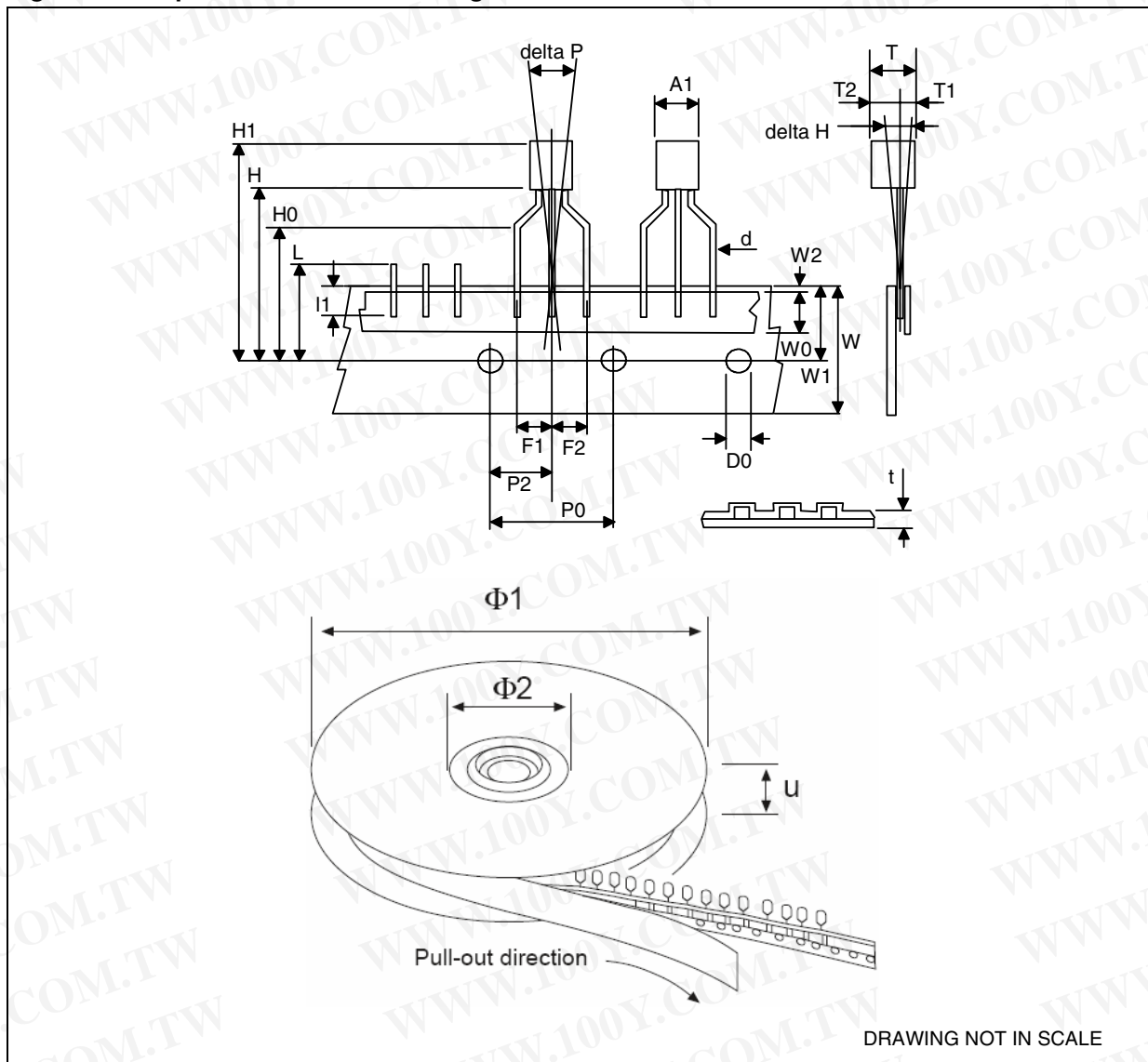

勝特力材料 886-3-5753170  
 勝特力电子(上海) 86-21-34970699  
 勝特力电子(深圳) 86-755-83298787  
[Http://www.100y.com.tw](http://www.100y.com.tw)

## 8 Order codes

Table 24. Order codes

Part numbers	Packages			Output voltages
	SO-8	TO92 (BAG) <sup>(1)</sup>	SOT-89	
L78L33C	L78L33CD-TR			3.3 V
L78L33AC	L78L33ACD13TR	L78L33ACZ	L78L33ACUTR	3.3 V
L78L33AB	L78L33ABD-TR	L78L33ABZ	L78L33ABUTR	3.3 V
L78L05C	L78L05CD13TR	L78L05CZ		5 V
L78L05AC	L78L05ACD13TR	L78L05ACZ	L78L05ACUTR	5 V
L78L05AB	L78L05ABD13TR	L78L05ABZ	L78L05ABUTR	5 V
L78L06AC	L78L06ACD13TR	L78L06ACZ	L78L06ACUTR	6 V
L78L06AB	L78L06ABD13TR	L78L06ABZ	L78L06ABUTR	6 V
L78L08C	L78L08CD13TR			8 V
L78L08AC	L78L08ACD13TR	L78L08ACZ	L78L08ACUTR	8 V
L78L08AB	L78L08ABD13TR	L78L08ABZ	L78L08ABUTR	8 V
L78L09C	L78L09CD13TR			9 V
L78L09AC	L78L09ACD13TR	L78L09ACZ	L78L09ACUTR	9 V
L78L09AB	L78L09ABD13TR	L78L09ABZ	L78L09ABUTR	9 V
L78L10AC			L78L10ACUTR	10 V
L78L12C	L78L12CD13TR			12 V
L78L12AC	L78L12ACD13TR	L78L12ACZ	L78L12ACUTR	12 V
L78L12AB	L78L12ABD-TR	L78L12ABZ	L78L12ABUTR	12 V
L78L15C	L78L15CD-TR			15 V
L78L15AC	L78L15ACD13TR	L78L15ACZ	L78L15ACUTR	15 V
L78L15AB		L78L15ABZ	L78L15ABUTR	15 V
L78L18C	L78L18CD13TR			18 V
L78L18AC			L78L18ACUTR	18 V
L78L24C	L78L24CD-TR			24 V
L78L24AC		L78L24ACZ	L78L24ACUTR	24 V
L78L24AB		L78L24ABZ		24 V

1. Available in Ammopak with the suffix "-AP" or in tape and reel with the suffix "TR". Please note that in these cases pins are shaped according to tape and reel specifications.

勝特力材料 886-3-5753170  
 勝特力电子(上海) 86-21-34970699  
 勝特力电子(深圳) 86-755-83298787  
[Http://www.100y.com.tw](http://www.100y.com.tw)

Table 25. Marking information

Part numbers	Marking	Packages	Output voltages
L78L05ABD	78L05B	SO8	5 V
L78L05ABUTR	8C	SOT 89	5 V
L78L05ABZ	L78L05	TO 92	5 V
L78L05ABZ-AP	L78L05	TO 92	5 V
L78L05ABZ-TR	L78L05	TO 92	5 V
L78L05ACD	78L05A	SO8	5 V
L78L05ACUTR	8C	SOT 89	5 V
L78L05ACZ	L78L05	TO 92	5 V
L78L05ACZ-AP	L78L05	TO 92	5 V
L78L05ACZTR	L78L05	TO 92	5 V
L78L05CD	78L05	SO8	5 V
L78L05CZ	L78L05	TO 92	5 V
L78L06ABD	78L06B	SO8	6 V
L78L06ABUTR	8E	SOT 89	6 V
L78L06ABZ	L78L06	TO 92	6 V
L78L06ACD	78L06A	SO8	6 V
L78L06ACUTR	8E	SOT 89	6 V
L78L06ACZ	L78L06	TO 92	6 V
L78L06ACZ-AP	L78L06	TO 92	6 V
L78L06ACZ-TR	L78L06	TO 92	6 V
L78L06CD	78L06	SO8	6 V
L78L08ABD	78L08B	SO8	8 V
L78L08ABUTR	8G	SOT 89	8 V
L78L08ABZ	L78L08	TO 92	8 V
L78L08ABZ-AP	L78L08	TO 92	8 V
L78L08ABZTR	L78L08	TO 92	8 V
L78L08ACD	78L08A	SO8	8 V
L78L08ACUTR	8G	SOT 89	8 V
L78L08ACZ	L78L08	TO 92	8 V
L78L08ACZ-AP	L78L08	TO 92	8 V
L78L08ACZTR	L78L08	TO 92	8 V
L78L08CD	78L08	SO8	8 V
L78L09ABD	78L09B	SO8	9 V
L78L09ABUTR	8H	SOT 89	9 V
L78L09ABZ	L78L09	TO 92	9 V

Table 25. Marking information (continued)

Part numbers	Marking	Packages	Output voltages
L78L09ACD	78L09A	SO8	9 V
L78L09ACUTR	8H	SOT 89	9 V
L78L09ACZ	L78L09	TO 92	9 V
L78L09ACZ-AP	L78L09	TO 92	9 V
L78L09ACZ-TR	L78L09	TO 92	9 V
L78L09CD	78L09	SO8	9 V
L78L10ACUTR	8I	SOT 89	10 V
L78L12ABD	78L12B	SO8	12 V
L78L12ABUTR	8K	SOT 89	12 V
L78L12ABZ	L78L12	TO 92	12 V
L78L12ABZ-AP	L78L12	TO 92	12 V
L78L12ACD	78L12A	SO8	12 V
L78L12ACUTR	8K	SOT 89	12 V
L78L12ACZ	L78L12	TO 92	12 V
L78L12ACZ-AP	L78L12	TO 92	12 V
L78L12ACZ-TR	L78L12	TO 92	12 V
L78L12CD	78L12	SO8	12 V
L78L15ABD	78L15B	SO8	15 V
L78L15ABUTR	8L	SOT 89	15 V
L78L15ABZ	L78L15	TO 92	15 V
L78L15ABZ-AP	L78L15	TO 92	15 V
L78L15ACD	78L15A	SO8	15 V
L78L15ACUTR	8L	SOT 89	15 V
L78L15ACZ	L78L15	TO 92	15 V
L78L15ACZ-AP	L78L15	TO 92	15 V
L78L15ACZ-TR	L78L15	TO 92	15 V
L78L15CD	78L15	SO8	15 V
L78L15CD-TR	78L15A	SO8	15 V
L78L18ACUTR	8B	SOT 89	18 V
L78L24ABD	78L24B	SO8	24 V
L78L24ABUTR	8P	SOT 89	24 V
L78L24ABZ-TR	L78L24	TO 92	24 V
L78L24ACD	78L24A	SO8	24 V
L78L24ACUTR	8P	SOT 89	24 V
L78L24ACZ	L78L24	TO 92	24 V
L78L24ACZ-AP	L78L24	TO 92	24 V

Table 25. Marking information (continued)

Part numbers	Marking	Packages	Output voltages
L78L24CD	78L24	SO8	24 V
L78L33ABD	78L33B	SO8	3.3 V
L78L33ABUTR	8A	SOT 89	3.3 V
L78L33ABZ-AP	L78L33	TO 92	3.3 V
L78L33ACD	78L33A	SO8	3.3 V
L78L33ACD13TR	78L33A	SO8	3.3 V
L78L33ACUTR	8A	SOT 89	3.3 V
L78L33ACZ	L78L33	TO 92	3.3 V
L78L33ACZ-AP	L78L33	TO 92	3.3 V
L78L33ACZTR	L78L33	TO 92	3.3 V
L78L33CD	78L33	SO8	3.3 V
L78L33CD-TR	78L33	SO8	3.3 V

勝特力材料 886-3-5753170  
 勝特力电子(上海) 86-21-34970699  
 勝特力电子(深圳) 86-755-83298787  
[Http://www.100y.com.tw](http://www.100y.com.tw)

## 9 Revision history

**Table 26. Document revision history**

Date	Revision	Changes
14-Mar-2005	9	Add tape and reel for TO-92.
15-Mar-2005	10	Add note on Table 3.
23-Dec-2005	11	Mistake on ordering Table in header.
12-Sep-2006	12	Order codes updated.
07-Jun-2007	13	Order codes updated.
18-Sep-2007	14	Added <a href="#">Table 1</a> in cover page.
15-Jul-2008	15	Modified: <a href="#">Table 1 on page 1</a> and <a href="#">Table 24 on page 28</a> .
18-Aug-2008	16	Modified <a href="#">Figure 12 on page 17</a> .
03-Apr-2009	17	Added: $R_{thJA}$ value for SOT-89 <a href="#">Table 3 on page 5</a> .
08-Feb-2011	18	Added note <a href="#">Table 23 on page 26</a>
21-Feb-2012	19	Modified: SOT-89 <a href="#">Figure 2 on page 4</a> .
14-Aug-2012	20	Updated $T_{OP}$ value for L78L00AC in <a href="#">Table 2 on page 5</a> . Minor text changes.
07-Sep-2012	21	Added: <a href="#">Table 25 on page 29</a> .

勝特力材料 886-3-5753170  
 勝特力电子(上海) 86-21-34970699  
 勝特力电子(深圳) 86-755-83298787  
[Http://www.100y.com.tw](http://www.100y.com.tw)

勝特力材料 886-3-5753170  
勝特力电子(上海) 86-21-34970699  
勝特力电子(深圳) 86-755-83298787  
[Http://www.100y.com.tw](http://www.100y.com.tw)

**Please Read Carefully:**

Information in this document is provided solely in connection with ST products. STMicroelectronics NV and its subsidiaries ("ST") reserve the right to make changes, corrections, modifications or improvements, to this document, and the products and services described herein at any time, without notice.

All ST products are sold pursuant to ST's terms and conditions of sale.

Purchasers are solely responsible for the choice, selection and use of the ST products and services described herein, and ST assumes no liability whatsoever relating to the choice, selection or use of the ST products and services described herein.

No license, express or implied, by estoppel or otherwise, to any intellectual property rights is granted under this document. If any part of this document refers to any third party products or services it shall not be deemed a license grant by ST for the use of such third party products or services, or any intellectual property contained therein or considered as a warranty covering the use in any manner whatsoever of such third party products or services or any intellectual property contained therein.

**UNLESS OTHERWISE SET FORTH IN ST'S TERMS AND CONDITIONS OF SALE ST DISCLAIMS ANY EXPRESS OR IMPLIED WARRANTY WITH RESPECT TO THE USE AND/OR SALE OF ST PRODUCTS INCLUDING WITHOUT LIMITATION IMPLIED WARRANTIES OF MERCHANTABILITY, FITNESS FOR A PARTICULAR PURPOSE (AND THEIR EQUIVALENTS UNDER THE LAWS OF ANY JURISDICTION), OR INFRINGEMENT OF ANY PATENT, COPYRIGHT OR OTHER INTELLECTUAL PROPERTY RIGHT.**

**UNLESS EXPRESSLY APPROVED IN WRITING BY TWO AUTHORIZED ST REPRESENTATIVES, ST PRODUCTS ARE NOT RECOMMENDED, AUTHORIZED OR WARRANTED FOR USE IN MILITARY, AIR CRAFT, SPACE, LIFE SAVING, OR LIFE SUSTAINING APPLICATIONS, NOR IN PRODUCTS OR SYSTEMS WHERE FAILURE OR MALFUNCTION MAY RESULT IN PERSONAL INJURY, DEATH, OR SEVERE PROPERTY OR ENVIRONMENTAL DAMAGE. ST PRODUCTS WHICH ARE NOT SPECIFIED AS "AUTOMOTIVE GRADE" MAY ONLY BE USED IN AUTOMOTIVE APPLICATIONS AT USER'S OWN RISK.**

Resale of ST products with provisions different from the statements and/or technical features set forth in this document shall immediately void any warranty granted by ST for the ST product or service described herein and shall not create or extend in any manner whatsoever, any liability of ST.

ST and the ST logo are trademarks or registered trademarks of ST in various countries.

Information in this document supersedes and replaces all information previously supplied.

The ST logo is a registered trademark of STMicroelectronics. All other names are the property of their respective owners.

© 2012 STMicroelectronics - All rights reserved

STMicroelectronics group of companies

Australia - Belgium - Brazil - Canada - China - Czech Republic - Finland - France - Germany - Hong Kong - India - Israel - Italy - Japan - Malaysia - Malta - Morocco - Philippines - Singapore - Spain - Sweden - Switzerland - United Kingdom - United States of America

[www.st.com](http://www.st.com)

