

# MC7900 Series

## 1.0 A Negative Voltage Regulators

The MC7900 series of fixed output negative voltage regulators are intended as complements to the popular MC7800 series devices. These negative regulators are available in the same seven-voltage options as the MC7800 devices. In addition, one extra voltage option commonly employed in MECL systems is also available in the negative MC7900 series.

Available in fixed output voltage options from  $-5.0\text{ V}$  to  $-24\text{ V}$ , these regulators employ current limiting, thermal shutdown, and safe-area compensation – making them remarkably rugged under most operating conditions. With adequate heatsinking they can deliver output currents in excess of 1.0 A.

- No External Components Required
- Internal Thermal Overload Protection
- Internal Short Circuit Current Limiting
- Output Transistor Safe-Area Compensation
- Available in 2% Voltage Tolerance (See Ordering Information)
- Pb-Free Package May be Available. The G-Suffix Denotes a Pb-Free Lead Finish

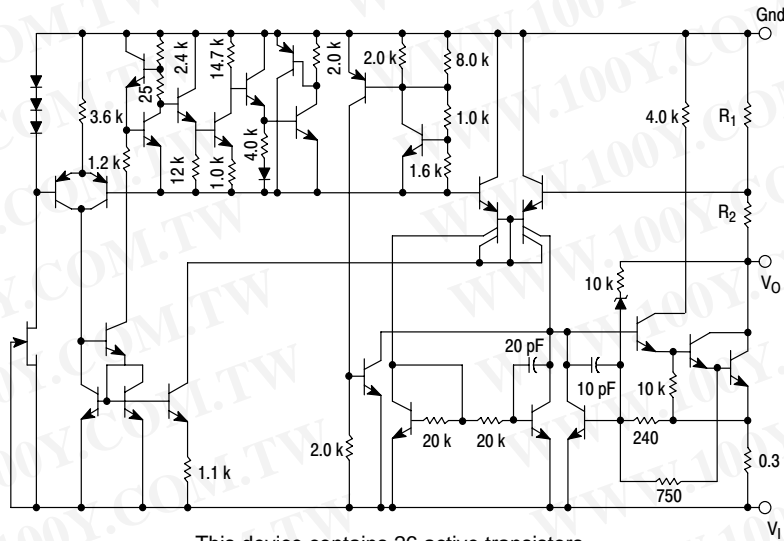

Figure 1. Representative Schematic Diagram



ON Semiconductor®

<http://onsemi.com>

TO-220  
T SUFFIX  
CASE 221AB

Heatsink surface  
connected to Pin 2.

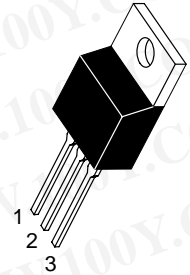

Pin 1. Ground  
2. Input  
3. Output

D<sup>2</sup>PAK  
D2T SUFFIX  
CASE 936

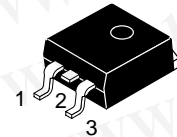

Heatsink surface (shown as terminal 4 in  
case outline drawing) is connected to Pin 2.

### STANDARD APPLICATION

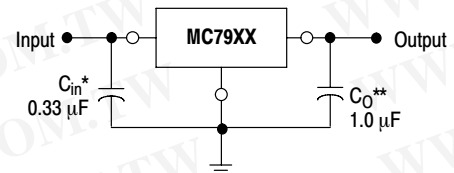

A common ground is required between the input and the output voltages. The input voltage must remain typically 2.0 V above more negative even during the high point of the input ripple voltage.

XX, These two digits of the type number indicate nominal voltage.

\*  $C_{in}$  is required if regulator is located an appreciable distance from power supply filter.

\*\*  $C_O$  improve stability and transient response.

### ORDERING INFORMATION

See detailed ordering and shipping information in the package dimensions section on page 11 of this data sheet.

### DEVICE MARKING INFORMATION

See general marking information in the device marking section on page 14 of this data sheet.

勝特力材料 886-3-5753170  
勝特力电子(上海) 86-21-34970699  
勝特力电子(深圳) 86-755-83298787  
[Http://www.100y.com.tw](http://www.100y.com.tw)

## MC7900 Series

### MAXIMUM RATINGS ( $T_A = +25^\circ\text{C}$ , unless otherwise noted.)

Rating	Symbol	Value	Unit
Input Voltage ( $-5.0\text{ V} \geq V_O \geq -18\text{ V}$ ) (24 V)	$V_I$	-35 -40	Vdc
Power Dissipation Case 221A $T_A = +25^\circ\text{C}$ Thermal Resistance, Junction-to-Ambient Thermal Resistance, Junction-to-Case Case 936 (D <sup>2</sup> PAK) $T_A = +25^\circ\text{C}$ Thermal Resistance, Junction-to-Ambient Thermal Resistance, Junction-to-Case	$P_D$ $\theta_{JA}$ $\theta_{JC}$ $P_D$ $\theta_{JA}$ $\theta_{JC}$	Internally Limited 65 5.0 Internally Limited 70 5.0	W $^\circ\text{C}/\text{W}$ $^\circ\text{C}/\text{W}$ W $^\circ\text{C}/\text{W}$ $^\circ\text{C}/\text{W}$
Storage Junction Temperature Range	$T_{stg}$	-65 to +150	$^\circ\text{C}$
Junction Temperature	$T_J$	+150	$^\circ\text{C}$

Stresses exceeding Maximum Ratings may damage the device. Maximum Ratings are stress ratings only. Functional operation above the Recommended Operating Conditions is not implied. Extended exposure to stresses above the Recommended Operating Conditions may affect device reliability.

\*This device series contains ESD protection and exceeds the following tests:

Human Body Model 2000 V per MIL\_STD\_883, Method 3015

Machine Model Method 200 V

### MC7905B, MC7905C

#### ELECTRICAL CHARACTERISTICS ( $V_I = -10\text{ V}$ , $I_O = 500\text{ mA}$ , $T_{low}^* < T_J < +125^\circ\text{C}$ , unless otherwise noted.)

Characteristics	Symbol	Min	Typ	Max	Unit
Output Voltage ( $T_J = +25^\circ\text{C}$ )	$V_O$	-4.8	-5.0	-5.2	Vdc
Line Regulation (Note 1) ( $T_J = +25^\circ\text{C}$ , $I_O = 100\text{ mA}$ ) $-7.0\text{ Vdc} \geq V_I \geq -25\text{ Vdc}$ $-8.0\text{ Vdc} \geq V_I \geq -12\text{ Vdc}$ ( $T_J = +25^\circ\text{C}$ , $I_O = 500\text{ mA}$ ) $-7.0\text{ Vdc} \geq V_I \geq -25\text{ Vdc}$ $-8.0\text{ Vdc} \geq V_I \geq -12\text{ Vdc}$	Reg <sub>line</sub>	- -	7.0 2.0	50 25	mV
Load Regulation, $T_J = +25^\circ\text{C}$ (Note 1) $5.0\text{ mA} \leq I_O \leq 1.5\text{ A}$ $250\text{ mA} \leq I_O \leq 750\text{ mA}$	Reg <sub>load</sub>	- -	11 4.0	100 50	mV
Output Voltage $-7.0\text{ Vdc} \geq V_I \geq -20\text{ Vdc}$ , $5.0\text{ mA} \leq I_O \leq 1.0\text{ A}$ , $P \leq 15\text{ W}$	$V_O$	-4.75	-	-5.25	Vdc
Input Bias Current ( $T_J = +25^\circ\text{C}$ )	$I_{IB}$	-	4.3	8.0	mA
Input Bias Current Change $-7.0\text{ Vdc} \geq V_I \geq -25\text{ Vdc}$ $5.0\text{ mA} \leq I_O \leq 1.5\text{ A}$	$\Delta I_{IB}$	- -	- -	1.3 0.5	mA
Output Noise Voltage ( $T_A = +25^\circ\text{C}$ , $10\text{ Hz} \leq f \leq 100\text{ kHz}$ )	$V_n$	-	40	-	$\mu\text{V}$
Ripple Rejection ( $I_O = 20\text{ mA}$ , $f = 120\text{ Hz}$ )	RR	-	70	-	dB
Dropout Voltage $I_O = 1.0\text{ A}$ , $T_J = +25^\circ\text{C}$	$V_I - V_O$	-	1.3	-	Vdc
Average Temperature Coefficient of Output Voltage $I_O = 5.0\text{ mA}$ , $T_{low}^* \leq T_J \leq +125^\circ\text{C}$	$\Delta V_O / \Delta T$	-	-1.0	-	$\text{mV}/^\circ\text{C}$

1. Load and line regulation are specified at constant junction temperature. Changes in  $V_O$  due to heating effects must be taken into account separately. Pulse testing with low duty cycle is used.

\* $T_{low} = -40^\circ\text{C}$  for MC7905B and  $T_{low} = 0^\circ\text{C}$  for MC7905C.

**勝特力材料 886-3-5753170**  
**勝特力电子(上海) 86-21-34970699**  
**勝特力电子(深圳) 86-755-83298787**  
[Http://www.100y.com.tw](http://www.100y.com.tw)

## MC7900 Series

### MC7905AC

**ELECTRICAL CHARACTERISTICS** ( $V_I = -10\text{ V}$ ,  $I_O = 500\text{ mA}$ ,  $0^\circ\text{C} < T_J < +125^\circ\text{C}$ , unless otherwise noted.)

Characteristics	Symbol	Min	Typ	Max	Unit
Output Voltage ( $T_J = +25^\circ\text{C}$ )	$V_O$	-4.9	-5.0	-5.1	Vdc
Line Regulation (Note 2) -8.0 Vdc $\geq V_I \geq -12\text{ Vdc}$ ; $I_O = 1.0\text{ A}$ , $T_J = +25^\circ\text{C}$ -8.0 Vdc $\geq V_I \geq -12\text{ Vdc}$ ; $I_O = 1.0\text{ A}$ -7.5 Vdc $\geq V_I \geq -25\text{ Vdc}$ ; $I_O = 500\text{ mA}$ -7.0 Vdc $\geq V_I \geq -20\text{ Vdc}$ ; $I_O = 1.0\text{ A}$ , $T_J = +25^\circ\text{C}$	$\text{Reg}_{\text{line}}$	-	2.0 7.0 7.0 6.0	25 50 50 50	mV
Load Regulation (Note 2) 5.0 mA $\leq I_O \leq 1.5\text{ A}$ , $T_J = +25^\circ\text{C}$ 250 mA $\leq I_O \leq 750\text{ mA}$ 5.0 mA $\leq I_O \leq 1.0\text{ A}$	$\text{Reg}_{\text{load}}$	-	11 4.0 9.0	100 50 100	mV
Output Voltage -7.5 Vdc $\geq V_I \geq -20\text{ Vdc}$ , 5.0 mA $\leq I_O \leq 1.0\text{ A}$ , $P \leq 15\text{ W}$	$V_O$	-4.80	-	-5.20	Vdc
Input Bias Current	$I_{\text{IB}}$	-	4.4	8.0	mA
Input Bias Current Change -7.5 Vdc $\geq V_I \geq -25\text{ Vdc}$ 5.0 mA $\leq I_O \leq 1.0\text{ A}$ 5.0 mA $\leq I_O \leq 1.5\text{ A}$ , $T_J = +25^\circ\text{C}$	$\Delta I_{\text{IB}}$	-	-	1.3 0.5 0.5	mA
Output Noise Voltage ( $T_A = +25^\circ\text{C}$ , 10 Hz $\leq f \leq 100\text{ kHz}$ )	$V_n$	-	40	-	$\mu\text{V}$
Ripple Rejection ( $I_O = \text{mA}$ , $f = 120\text{ Hz}$ )	RR	-	70	-	dB
Dropout Voltage ( $I_O = 1.0\text{ A}$ , $T_J = +25^\circ\text{C}$ )	$V_I - V_O$	-	1.3	-	Vdc
Average Temperature Coefficient of Output Voltage $I_O = 5.0\text{ A}$ , $0^\circ\text{C} \leq T_J \leq +125^\circ\text{C}$	$\Delta V_O / \Delta T$	-	-1.0	-	mV/ $^\circ\text{C}$

### MC7905.2C

**ELECTRICAL CHARACTERISTICS** ( $V_I = -10\text{ V}$ ,  $I_O = 500\text{ mA}$ ,  $0^\circ\text{C} < T_J < +125^\circ\text{C}$ , unless otherwise noted.)

Characteristics	Symbol	Min	Typ	Max	Unit
Output Voltage ( $T_J = +25^\circ\text{C}$ )	$V_O$	-5.0	-5.2	-5.4	Vdc
Line Regulation (Note 2) ( $T_J = +25^\circ\text{C}$ , $I_O = 100\text{ mA}$ ) -7.2 Vdc $\geq V_I \geq -25\text{ Vdc}$ -8.0 Vdc $\geq V_I \geq -12\text{ Vdc}$ ( $T_J = +25^\circ\text{C}$ , $I_O = 500\text{ mA}$ ) -7.2 Vdc $\geq V_I \geq -25\text{ Vdc}$ -8.0 Vdc $\geq V_I \geq -12\text{ Vdc}$	$\text{Reg}_{\text{line}}$	-	8.0 2.2 37 8.5	52 27 105 52	mV
Load Regulation, $T_J = +25^\circ\text{C}$ (Note 2) 5.0 mA $\leq I_O \leq 1.5\text{ A}$ 250 mA $\leq I_O \leq 750\text{ mA}$	$\text{Reg}_{\text{load}}$	-	12 4.5	105 52	mV
Output Voltage -7.2 Vdc $\geq V_I \geq -20\text{ Vdc}$ , 5.0 mA $\leq I_O \leq 1.0\text{ A}$ , $P \leq 15\text{ W}$	$V_O$	-4.95	-	-5.45	Vdc
Input Bias Current ( $T_J = +25^\circ\text{C}$ )	$I_{\text{IB}}$	-	4.3	8.0	mA
Input Bias Current Change -7.2 Vdc $\geq V_I \geq -25\text{ Vdc}$ 5.0 mA $\leq I_O \leq 1.5\text{ A}$	$\Delta I_{\text{IB}}$	-	-	1.3 0.5	mA
Output Noise Voltage ( $T_A = +25^\circ\text{C}$ , 10 Hz $\leq f \leq 100\text{ kHz}$ )	$V_n$	-	42	-	$\mu\text{V}$
Ripple Rejection ( $I_O = 20\text{ mA}$ , $f = 120\text{ Hz}$ )	RR	-	68	-	dB
Dropout Voltage ( $I_O = 1.0\text{ A}$ , $T_J = +25^\circ\text{C}$ )	$V_I - V_O$	-	1.3	-	Vdc
Average Temperature Coefficient of Output Voltage $I_O = 5.0\text{ mA}$ , $0^\circ\text{C} \leq T_J \leq +125^\circ\text{C}$	$\Delta V_O / \Delta T$	-	-1.0	-	mV/ $^\circ\text{C}$

2. Load and line regulation are specified at constant junction temperature. Changes in  $V_O$  due to heating effects must be taken into account separately. Pulse testing with low duty cycle is used.

## MC7900 Series

### MC7906C

**ELECTRICAL CHARACTERISTICS** ( $V_I = -11\text{ V}$ ,  $I_O = 500\text{ mA}$ ,  $0^\circ\text{C} < T_J < +125^\circ\text{C}$ , unless otherwise noted.)

Characteristics	Symbol	Min	Typ	Max	Unit
Output Voltage ( $T_J = +25^\circ\text{C}$ )	$V_O$	-5.75	-6.0	-6.25	Vdc
Line Regulation (Note 3) ( $T_J = +25^\circ\text{C}$ , $I_O = 100\text{ mA}$ ) -8.0 Vdc $\geq V_I \geq -25\text{ Vdc}$ -9.0 Vdc $\geq V_I \geq -13\text{ Vdc}$ ( $T_J = +25^\circ\text{C}$ , $I_O = 500\text{ mA}$ ) -8.0 Vdc $\geq V_I \geq -25\text{ Vdc}$ -9.0 Vdc $\geq V_I \geq -13\text{ Vdc}$	$\text{Reg}_{\text{line}}$	-	9.0 3.0	60 30	mV
Load Regulation, $T_J = +25^\circ\text{C}$ (Note 3) $5.0\text{ mA} \leq I_O \leq 1.5\text{ A}$ $250\text{ mA} \leq I_O \leq 750\text{ mA}$	$\text{Reg}_{\text{load}}$	-	13 5.0	120 60	mV
Output Voltage -8.0 Vdc $\geq V_I \geq -21\text{ Vdc}$ , $5.0\text{ mA} \leq I_O \leq 1.0\text{ A}$ , $P \leq 15\text{ W}$	$V_O$	-5.7	-	-6.3	Vdc
Input Bias Current ( $T_J = +25^\circ\text{C}$ )	$I_{\text{IB}}$	-	4.3	8.0	mA
Input Bias Current Change -8.0 Vdc $\geq V_I \geq -25\text{ Vdc}$ $5.0\text{ mA} \leq I_O \leq 1.5\text{ A}$	$\Delta I_{\text{IB}}$	-	-	1.3 0.5	mA
Output Noise Voltage ( $T_A = +25^\circ\text{C}$ , $10\text{ Hz} \leq f \leq 100\text{ kHz}$ )	$V_n$	-	45	-	$\mu\text{V}$
Ripple Rejection ( $I_O = 20\text{ mA}$ , $f = 120\text{ Hz}$ )	RR	-	65	-	dB
Dropout Voltage ( $I_O = 1.0\text{ A}$ , $T_J = +25^\circ\text{C}$ )	$V_I - V_O$	-	1.3	-	Vdc
Average Temperature Coefficient of Output Voltage $I_O = 5.0\text{ A}$ , $0^\circ\text{C} \leq T_J \leq +125^\circ\text{C}$	$\Delta V_O / \Delta T$	-	-1.0	-	$\text{mV}/^\circ\text{C}$

### MC7908C

**ELECTRICAL CHARACTERISTICS** ( $V_I = -14\text{ V}$ ,  $I_O = 500\text{ mA}$ ,  $0^\circ\text{C} < T_J < +125^\circ\text{C}$ , unless otherwise noted.)

Characteristics	Symbol	Min	Typ	Max	Unit
Output Voltage ( $T_J = +25^\circ\text{C}$ )	$V_O$	-7.7	-8.0	-8.3	Vdc
Line Regulation (Note 3) ( $T_J = +25^\circ\text{C}$ , $I_O = 100\text{ mA}$ ) -10.5 Vdc $\geq V_I \geq -25\text{ Vdc}$ -11 Vdc $\geq V_I \geq -17\text{ Vdc}$ ( $T_J = +25^\circ\text{C}$ , $I_O = 500\text{ mA}$ ) -10.5 Vdc $\geq V_I \geq -25\text{ Vdc}$ -11 Vdc $\geq V_I \geq -17\text{ Vdc}$	$\text{Reg}_{\text{line}}$	-	12 5.0	80 40	mV
Load Regulation, $T_J = +25^\circ\text{C}$ (Note 3) $5.0\text{ mA} \leq I_O \leq 1.5\text{ A}$ $250\text{ mA} \leq I_O \leq 750\text{ mA}$	$\text{Reg}_{\text{load}}$	-	26 9.0	160 80	mV
Output Voltage -10.5 Vdc $\geq V_I \geq -23\text{ Vdc}$ , $5.0\text{ mA} \leq I_O \leq 1.0\text{ A}$ , $P \leq 15\text{ W}$	$V_O$	-7.6	-	-8.4	Vdc
Input Bias Current ( $T_J = +25^\circ\text{C}$ )	$I_{\text{IB}}$	-	4.3	8.0	mA
Input Bias Current Change -10.5 Vdc $\geq V_I \geq -25\text{ Vdc}$ $5.0\text{ mA} \leq I_O \leq 1.5\text{ A}$	$\Delta I_{\text{IB}}$	-	-	1.0 0.5	mA
Output Noise Voltage ( $T_A = +25^\circ\text{C}$ , $10\text{ Hz} \leq f \leq 100\text{ kHz}$ )	$V_n$	-	52	-	$\mu\text{V}$
Ripple Rejection ( $I_O = 20\text{ mA}$ , $f = 120\text{ Hz}$ )	RR	-	62	-	dB
Dropout Voltage ( $I_O = 1.0\text{ A}$ , $T_J = +25^\circ\text{C}$ )	$V_I - V_O$	-	1.3	-	Vdc
Average Temperature Coefficient of Output Voltage $I_O = 5.0\text{ mA}$ , $0^\circ\text{C} \leq T_J \leq +125^\circ\text{C}$	$\Delta V_O / \Delta T$	-	-1.0	-	$\text{mV}/^\circ\text{C}$

3. Load and line regulation are specified at constant junction temperature. Changes in  $V_O$  due to heating effects must be taken into account separately. Pulse testing with low duty cycle is used.

## MC7900 Series

### MC7912B, MC7912C

**ELECTRICAL CHARACTERISTICS** ( $V_I = -19\text{ V}$ ,  $I_O = 500\text{ mA}$ ,  $T_{low}^* < T_J < +125^\circ\text{C}$ , unless otherwise noted.)

Characteristics	Symbol	Min	Typ	Max	Unit
Output Voltage ( $T_J = +25^\circ\text{C}$ )	$V_O$	-11.5	-12	-12.5	Vdc
Line Regulation (Note 4) ( $T_J = +25^\circ\text{C}$ , $I_O = 100\text{ mA}$ ) -14.5 Vdc $\geq V_I \geq -30\text{ Vdc}$ -16 Vdc $\geq V_I \geq -22\text{ Vdc}$ ( $T_J = +25^\circ\text{C}$ , $I_O = 500\text{ mA}$ ) -14.5 Vdc $\geq V_I \geq -30\text{ Vdc}$ -16 Vdc $\geq V_I \geq -22\text{ Vdc}$	$Reg_{line}$	-	13 6.0	120 60	mV
Load Regulation, $T_J = +25^\circ\text{C}$ (Note 4) $5.0\text{ mA} \leq I_O \leq 1.5\text{ A}$ $250\text{ mA} \leq I_O \leq 750\text{ mA}$	$Reg_{load}$	-	46 17	240 120	mV
Output Voltage -14.5 Vdc $\geq V_I \geq -27\text{ Vdc}$ , $5.0\text{ mA} \leq I_O \leq 1.0\text{ A}$ , $P \leq 15\text{ W}$	$V_O$	-11.4	-	-12.6	Vdc
Input Bias Current ( $T_J = +25^\circ\text{C}$ )	$I_{IB}$	-	4.4	8.0	mA
Input Bias Current Change -14.5 Vdc $\geq V_I \geq -30\text{ Vdc}$ $5.0\text{ mA} \leq I_O \leq 1.5\text{ A}$	$\Delta I_{IB}$	-	-	1.0 0.5	mA
Output Noise Voltage ( $T_A = +25^\circ\text{C}$ , $10\text{ Hz} \leq f \leq 100\text{ kHz}$ )	$V_n$	-	75	-	$\mu\text{V}$
Ripple Rejection ( $I_O = 20\text{ mA}$ , $f = 120\text{ Hz}$ )	RR	-	61	-	dB
Dropout Voltage ( $I_O = 1.0\text{ A}$ , $T_J = +25^\circ\text{C}$ )	$V_I - V_O$	-	1.3	-	Vdc
Average Temperature Coefficient of Output Voltage $I_O = 5.0\text{ mA}$ , $T_{low}^* \leq T_J \leq +125^\circ\text{C}$	$\Delta V_O / \Delta T$	-	-1.0	-	$\text{mV}/^\circ\text{C}$

### MC7912AC

**ELECTRICAL CHARACTERISTICS** ( $V_I = -19\text{ V}$ ,  $I_O = 500\text{ mA}$ ,  $T_{low}^* < T_J < +125^\circ\text{C}$ , unless otherwise noted.)

Characteristics	Symbol	Min	Typ	Max	Unit
Output Voltage ( $T_J = +25^\circ\text{C}$ )	$V_O$	-11.75	-12	-12.25	Vdc
Line Regulation (Note 4) -16 Vdc $\geq V_I \geq -22\text{ Vdc}$ ; $I_O = 1.0\text{ A}$ , $T_J = +25^\circ\text{C}$ -16 Vdc $\geq V_I \geq -22\text{ Vdc}$ ; $I_O = 1.0\text{ A}$ -14.8 Vdc $\geq V_I \geq -30\text{ Vdc}$ ; $I_O = 500\text{ mA}$ -14.5 Vdc $\geq V_I \geq -27\text{ Vdc}$ ; $I_O = 1.0\text{ A}$ , $T_J = +25^\circ\text{C}$	$Reg_{line}$	-	6.0 24 24 13	60 120 120 120	mV
Load Regulation (Note 4) $5.0\text{ mA} \leq I_O \leq 1.5\text{ A}$ , $T_J = +25^\circ\text{C}$ $250\text{ mA} \leq I_O \leq 750\text{ mA}$ $5.0\text{ mA} \leq I_O \leq 1.0\text{ A}$	$Reg_{load}$	-	46 17 35	150 75 150	mV
Output Voltage -14.8 Vdc $\geq V_I \geq -27\text{ Vdc}$ , $5.0\text{ mA} \leq I_O \leq 1.0\text{ A}$ , $P \leq 15\text{ W}$	$V_O$	-11.5	-	-12.5	Vdc
Input Bias Current	$I_{IB}$	-	4.4	8.0	mA
Input Bias Current Change -15 Vdc $\geq V_I \geq -30\text{ Vdc}$ $5.0\text{ mA} \leq I_O \leq 1.0\text{ A}$ $5.0\text{ mA} \leq I_O \leq 1.5\text{ A}$ , $T_J = +25^\circ\text{C}$	$\Delta I_{IB}$	-	-	0.8 0.5 0.5	mA
Output Noise Voltage ( $T_A = +25^\circ\text{C}$ , $10\text{ Hz} \leq f \leq 100\text{ kHz}$ )	$V_n$	-	75	-	$\mu\text{V}$
Ripple Rejection ( $I_O = 20\text{ mA}$ , $f = 120\text{ Hz}$ )	RR	-	61	-	dB
Dropout Voltage ( $I_O = 1.0\text{ A}$ , $T_J = +25^\circ\text{C}$ )	$V_I - V_O$	-	1.3	-	Vdc
Average Temperature Coefficient of Output Voltage $I_O = 5.0\text{ mA}$ , $T_{low}^* \leq T_J \leq +125^\circ\text{C}$	$\Delta V_O / \Delta T$	-	-1.0	-	$\text{mV}/^\circ\text{C}$

4. Load and line regulation are specified at constant junction temperature. Changes in  $V_O$  due to heating effects must be taken into account separately. Pulse testing with low duty cycle is used.

\* $T_{low} = -40^\circ\text{C}$  for MC7912B and  $T_{low} = 0^\circ\text{C}$  for MC7912C.

## MC7900 Series

### MC7915B, MC7915C

**ELECTRICAL CHARACTERISTICS** ( $V_I = -23\text{ V}$ ,  $I_O = 500\text{ mA}$ ,  $T_{low}^* < T_J < +125^\circ\text{C}$ , unless otherwise noted.)

Characteristics	Symbol	Min	Typ	Max	Unit
Output Voltage ( $T_J = +25^\circ\text{C}$ )	$V_O$	-14.4	-15	-15.6	Vdc
Line Regulation (Note 5) ( $T_J = +25^\circ\text{C}$ , $I_O = 100\text{ mA}$ ) -17.5 Vdc $\geq V_I \geq -30\text{ Vdc}$ -20 Vdc $\geq V_I \geq -26\text{ Vdc}$ ( $T_J = +25^\circ\text{C}$ , $I_O = 500\text{ mA}$ ) -17.5 Vdc $\geq V_I \geq -30\text{ Vdc}$ -20 Vdc $\geq V_I \geq -26\text{ Vdc}$	$Reg_{line}$	-	14 6.0	150 75	mV
Load Regulation, $T_J = +25^\circ\text{C}$ (Note 5) $5.0\text{ mA} \leq I_O \leq 1.5\text{ A}$ $250\text{ mA} \leq I_O \leq 750\text{ mA}$	$Reg_{load}$	-	68 25	300 150	mV
Output Voltage -17.5 Vdc $\geq V_I \geq -30\text{ Vdc}$ , $5.0\text{ mA} \leq I_O \leq 1.0\text{ A}$ , $P \leq 15\text{ W}$	$V_O$	-14.25	-	-15.75	Vdc
Input Bias Current ( $T_J = +25^\circ\text{C}$ )	$I_{IB}$	-	4.4	8.0	mA
Input Bias Current Change -17.5 Vdc $\geq V_I \geq -30\text{ Vdc}$ $5.0\text{ mA} \leq I_O \leq 1.5\text{ A}$	$\Delta I_{IB}$	-	-	1.0 0.5	mA
Output Noise Voltage ( $T_A = +25^\circ\text{C}$ , $10\text{ Hz} \leq f \leq 100\text{ kHz}$ )	$V_n$	-	90	-	$\mu\text{V}$
Ripple Rejection ( $I_O = 20\text{ mA}$ , $f = 120\text{ Hz}$ )	RR	-	60	-	dB
Dropout Voltage ( $I_O = 1.0\text{ A}$ , $T_J = +25^\circ\text{C}$ )	$V_I - V_O$	-	1.3	-	Vdc
Average Temperature Coefficient of Output Voltage $I_O = 5.0\text{ A}$ , $T_{low}^* \leq T_J \leq +125^\circ\text{C}$	$\Delta V_O / \Delta T$	-	-1.0	-	$\text{mV}/^\circ\text{C}$

### MC7915AC

**ELECTRICAL CHARACTERISTICS** ( $V_I = -23\text{ V}$ ,  $I_O = 500\text{ mA}$ ,  $T_{low}^* < T_J < +125^\circ\text{C}$ , unless otherwise noted.)

Characteristics	Symbol	Min	Typ	Max	Unit
Output Voltage ( $T_J = +25^\circ\text{C}$ )	$V_O$	-14.7	-15	-15.3	Vdc
Line Regulation (Note 5) -20 Vdc $\geq V_I \geq -26\text{ Vdc}$ , $I_O = 1.0\text{ A}$ , $T_J = +25^\circ\text{C}$ -20 Vdc $\geq V_I \geq -26\text{ Vdc}$ , $I_O = 1.0\text{ A}$ , -17.9 Vdc $\geq V_I \geq -30\text{ Vdc}$ , $I_O = 500\text{ mA}$ -17.5 Vdc $\geq V_I \geq -30\text{ Vdc}$ , $I_O = 1.0\text{ A}$ , $T_J = +25^\circ\text{C}$	$Reg_{line}$	-	27 57 57 57	75 150 150 150	mV
Load Regulation (Note 5) $5.0\text{ mA} \leq I_O \leq 1.5\text{ A}$ , $T_J = +25^\circ\text{C}$ $250\text{ mA} \leq I_O \leq 750\text{ mA}$ $5.0\text{ mA} \leq I_O \leq 1.0\text{ A}$	$Reg_{load}$	-	68 25 40	150 75 150	mV
Output Voltage -17.9 Vdc $\geq V_I \geq -30\text{ Vdc}$ , $5.0\text{ mA} \leq I_O \leq 1.0\text{ A}$ , $P \leq 15\text{ W}$	$V_O$	-14.4	-	-15.6	Vdc
Input Bias Current	$I_{IB}$	-	4.4	8.0	mA
Input Bias Current Change -17.5 Vdc $\geq V_I \geq -30\text{ Vdc}$ $5.0\text{ mA} \leq I_O \leq 1.0\text{ A}$ $5.0\text{ mA} \leq I_O \leq 1.5\text{ A}$ , $T_J = +25^\circ\text{C}$	$\Delta I_{IB}$	-	-	0.8 0.5 0.5	mA
Output Noise Voltage ( $T_A = +25^\circ\text{C}$ , $10\text{ Hz} \leq f \leq 100\text{ kHz}$ )	$V_n$	-	90	-	$\mu\text{V}$
Ripple Rejection ( $I_O = 20\text{ mA}$ , $f = 120\text{ Hz}$ )	RR	-	60	-	dB
Dropout Voltage ( $I_O = 1.0\text{ A}$ , $T_J = +25^\circ\text{C}$ )	$V_I - V_O$	-	1.3	-	Vdc
Average Temperature Coefficient of Output Voltage $I_O = 5.0\text{ mA}$ , $T_{low}^* \leq T_J \leq +125^\circ\text{C}$	$\Delta V_O / \Delta T$	-	-1.0	-	$\text{mV}/^\circ\text{C}$

5. Load and line regulation are specified at constant junction temperature. Changes in  $V_O$  due to heating effects must be taken into account separately. Pulse testing with low duty cycle is used.

\* $T_{low} = -40^\circ\text{C}$  for MC7915B and  $T_{low} = 0^\circ\text{C}$  for MC7915C.

**勝特力材料 886-3-5753170**  
**勝特力电子(上海) 86-21-34970699**  
**勝特力电子(深圳) 86-755-83298787**  
[Http://www.100y.com.tw](http://www.100y.com.tw)

## MC7900 Series

### MC7918C

**ELECTRICAL CHARACTERISTICS** ( $V_I = -27\text{ V}$ ,  $I_O = 500\text{ mA}$ ,  $0^\circ\text{C} < T_J < +125^\circ\text{C}$ , unless otherwise noted.)

Characteristics	Symbol	Min	Typ	Max	Unit
Output Voltage ( $T_J = +25^\circ\text{C}$ )	$V_O$	-17.3	-18	-18.7	Vdc
Line Regulation (Note 6) ( $T_J = +25^\circ\text{C}$ , $I_O = 100\text{ mA}$ ) -21 Vdc $\geq V_I \geq -33\text{ Vdc}$ -24 Vdc $\geq V_I \geq -30\text{ Vdc}$ ( $T_J = +25^\circ\text{C}$ , $I_O = 500\text{ mA}$ ) -21 Vdc $\geq V_I \geq -33\text{ Vdc}$ -24 Vdc $\geq V_I \geq -30\text{ Vdc}$	$\text{Reg}_{\text{line}}$	-	25 10	180 90	mV
Load Regulation, $T_J = +25^\circ\text{C}$ (Note 6) $5.0\text{ mA} \leq I_O \leq 1.5\text{ A}$ $250\text{ mA} \leq I_O \leq 750\text{ mA}$	$\text{Reg}_{\text{load}}$	-	110 55	360 180	mV
Output Voltage -21 Vdc $\geq V_I \geq -33\text{ Vdc}$ , $5.0\text{ mA} \leq I_O \leq 1.0\text{ A}$ , $P \leq 15\text{ W}$	$V_O$	-17.1	-	-18.9	Vdc
Input Bias Current ( $T_J = +25^\circ\text{C}$ )	$I_{\text{IB}}$	-	4.5	8.0	mA
Input Bias Current Change -21 Vdc $\geq V_I \geq -33\text{ Vdc}$ $5.0\text{ mA} \leq I_O \leq 1.5\text{ A}$	$\Delta I_{\text{IB}}$	-	-	1.0 0.5	mA
Output Noise Voltage ( $T_A = +25^\circ\text{C}$ , $10\text{ Hz} \leq f \leq 100\text{ kHz}$ )	$V_n$	-	110	-	$\mu\text{V}$
Ripple Rejection ( $I_O = 20\text{ mA}$ , $f = 120\text{ Hz}$ )	RR	-	59	-	dB
Dropout Voltage ( $I_O = 1.0\text{ A}$ , $T_J = +25^\circ\text{C}$ )	$V_I - V_O$	-	1.3	-	Vdc
Average Temperature Coefficient of Output Voltage $I_O = 5.0\text{ mA}$ , $0^\circ\text{C} \leq T_J \leq +125^\circ\text{C}$	$\Delta V_O / \Delta T$	-	-1.0	-	$\text{mV}/^\circ\text{C}$

### MC7924B, MC7924C

**ELECTRICAL CHARACTERISTICS** ( $V_I = -33\text{ V}$ ,  $I_O = 500\text{ mA}$ ,  $T_{\text{low}}^* < T_J < +125^\circ\text{C}$ , unless otherwise noted.)

Characteristics	Symbol	Min	Typ	Max	Unit
Output Voltage ( $T_J = +25^\circ\text{C}$ )	$V_O$	-23	-24	-25	Vdc
Line Regulation (Note 6) ( $T_J = +25^\circ\text{C}$ , $I_O = 100\text{ mA}$ ) -27 Vdc $\geq V_I \geq -38\text{ Vdc}$ -30 Vdc $\geq V_I \geq -36\text{ Vdc}$ ( $T_J = +25^\circ\text{C}$ , $I_O = 500\text{ mA}$ ) -27 Vdc $\geq V_I \geq -38\text{ Vdc}$ -30 Vdc $\geq V_I \geq -36\text{ Vdc}$	$\text{Reg}_{\text{line}}$	-	31 14	240 120	mV
Load Regulation, $T_J = +25^\circ\text{C}$ (Note 6) $5.0\text{ mA} \leq I_O \leq 1.5\text{ A}$ $250\text{ mA} \leq I_O \leq 750\text{ mA}$	$\text{Reg}_{\text{load}}$	-	150 85	480 240	mV
Output Voltage -27 Vdc $\geq V_I \geq -38\text{ Vdc}$ , $5.0\text{ mA} \leq I_O \leq 1.0\text{ A}$ , $P \leq 15\text{ W}$	$V_O$	-22.8	-	-25.2	Vdc
Input Bias Current ( $T_J = +25^\circ\text{C}$ )	$I_{\text{IB}}$	-	4.6	8.0	mA
Input Bias Current Change -27 Vdc $\geq V_I \geq -38\text{ Vdc}$ $5.0\text{ mA} \leq I_O \leq 1.5\text{ A}$	$\Delta I_{\text{IB}}$	-	-	1.0 0.5	mA
Output Noise Voltage ( $T_A = +25^\circ\text{C}$ , $10\text{ Hz} \leq f \leq 100\text{ kHz}$ )	$V_n$	-	170	-	$\mu\text{V}$
Ripple Rejection ( $I_O = 20\text{ mA}$ , $f = 120\text{ Hz}$ )	RR	-	56	-	dB
Dropout Voltage ( $I_O = 1.0\text{ A}$ , $T_J = +25^\circ\text{C}$ )	$V_I - V_O$	-	1.3	-	Vdc
Average Temperature Coefficient of Output Voltage $I_O = 5.0\text{ mA}$ , $T_{\text{low}}^* \leq T_J \leq +125^\circ\text{C}$	$\Delta V_O / \Delta T$	-	-1.0	-	$\text{mV}/^\circ\text{C}$

6. Load and line regulation are specified at constant junction temperature. Changes in  $V_O$  due to heating effects must be taken into account separately. Pulse testing with low duty cycle is used.

\* $T_{\text{low}} = -40^\circ\text{C}$  for MC7924B and  $T_{\text{low}} = 0^\circ\text{C}$  for MC7924C.

# MC7900 Series

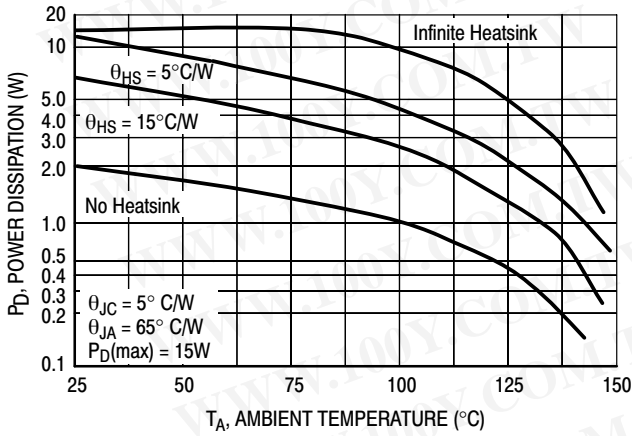

**Figure 2. Worst Case Power Dissipation as a Function of Ambient Temperature**

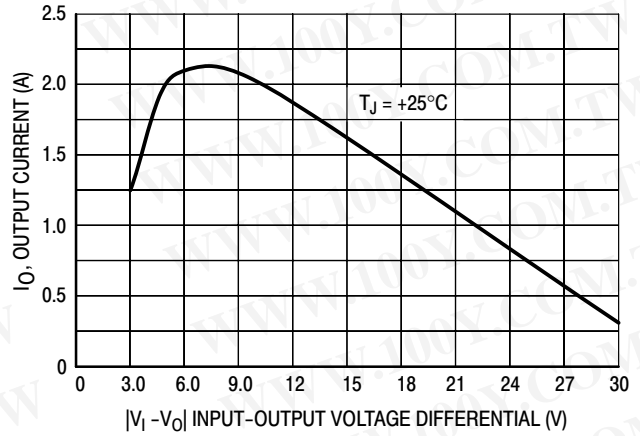

**Figure 3. Peak Output Current as a Function of Input-Output Differential Voltage**

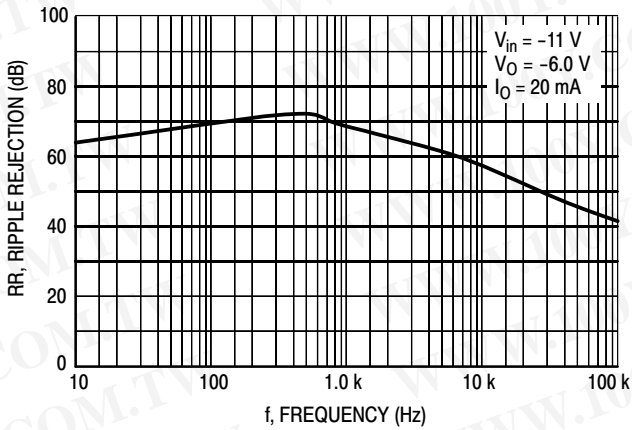

**Figure 4. Ripple Rejection as a Function of Frequency**

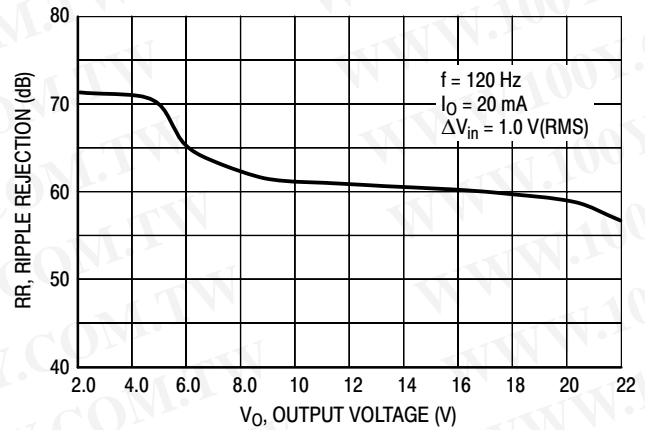

**Figure 5. Ripple Rejection as a Function of Output Voltage**

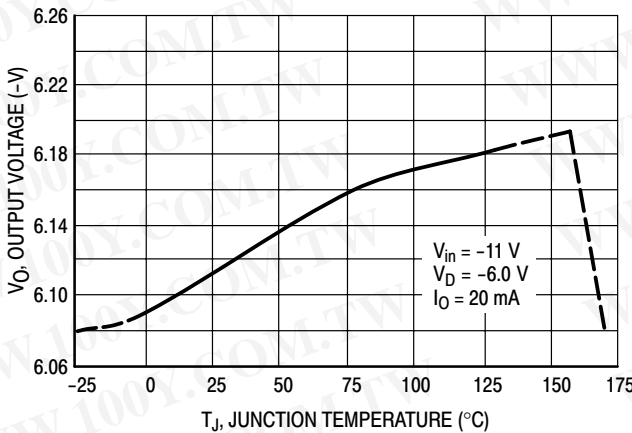

**Figure 6. Output Voltage as a Function of Junction Temperature**

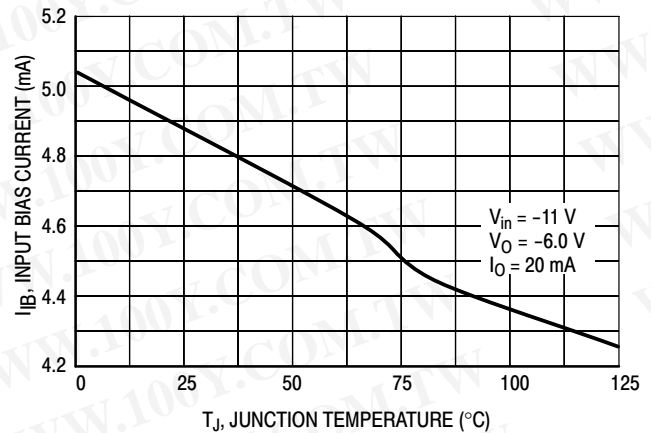

**Figure 7. Quiescent Current as a Function of Temperature**

# MC7900 Series

## APPLICATIONS INFORMATION

### Design Considerations

The MC7900 Series of fixed voltage regulators are designed with Thermal overload Protection that shuts down the circuit when subjected to an excessive power overload condition. Internal Short Circuit Protection that limits the maximum current the circuit will pass, and Output Transistor Safe-Area Compensation that reduces the output short circuit current as the voltage across the pass transistor is increased.

In many low current applications, compensation capacitors are not required. However, it is recommended that the regulator input be bypassed with a capacitor if the regulator is connected to the power supply filter with long wire lengths, or if the output load capacitance is large. An input bypass capacitor should be selected to provide good high-frequency characteristics to insure stable operation under all load conditions. A 0.33  $\mu\text{F}$  or larger tantalum, mylar, or other capacitor having low internal impedance at high frequencies should be chosen. The capacitor chosen should have an equivalent series resistance of less than 0.7  $\Omega$ . The bypass capacitor should be mounted with the shortest possible leads directly across the regulators input terminals. Normally good construction techniques should be

used to minimize ground loops and lead resistance drops since the regulator has no external sense lead. Bypassing the output is also recommended.

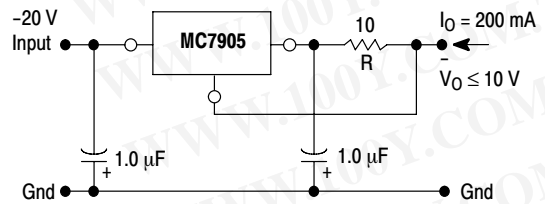

The MC7905, -5.0 V regulator can be used as a constant current source when connected as above. The output current is the sum of resistor R current and quiescent bias current as follows.

$$I_O = \frac{5.0 \text{ V}}{R} + I_B$$

The quiescent current for this regulator is typically 4.3 mA. The 5.0 V regulator was chosen to minimize dissipation and to allow the output voltage to operate to within 6.0 V below the input voltage.

Figure 8. Current Regulator

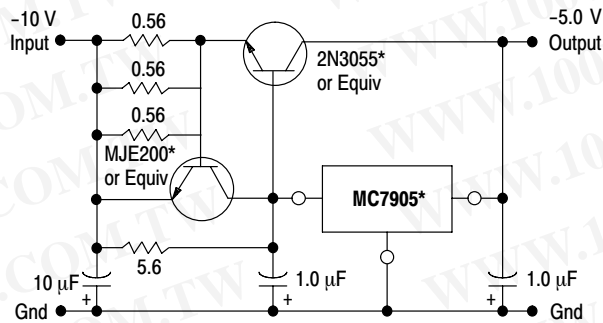

\*Mounted on heatsink.

When a boost transistor is used, short circuit currents are equal to the sum of the series pass and regulator limits, which are measured at 3.2 A and 1.8 A respectively in this case. Series pass limiting is approximately equal to 0.6 V/R<sub>SC</sub>. Operation beyond this point to the peak current capability of the MC7905C is possible if the regulator is mounted on a heatsink; otherwise thermal shutdown will occur when the additional load current is picked up by the regulator.

Figure 9. Current Boost Regulator  
(-5.0 V @ 4.0 A, with 5.0 A Current Limiting)

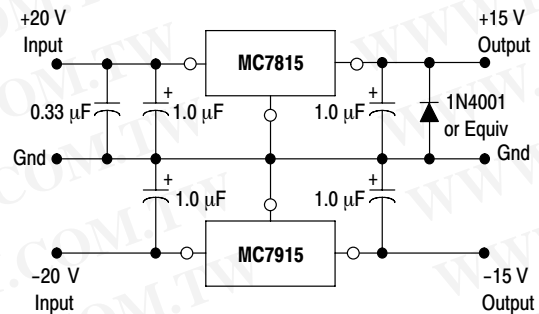

The MC7815 and MC7915 positive and negative regulators may be connected as shown to obtain a dual power supply for operational amplifiers. A clamp diode should be used at the output of the MC7815 to prevent potential latch-up problems whenever the output of the positive regulator (MC7815) is drawn below ground with an output current greater than 200 mA.

Figure 10. Operational Amplifier Supply  
(±15 @ 1.0 A)

勝特力材料 886-3-5753170  
 勝特力电子(上海) 86-21-34970699  
 勝特力电子(深圳) 86-755-83298787  
[Http://www.100y.com.tw](http://www.100y.com.tw)

## MC7900 Series

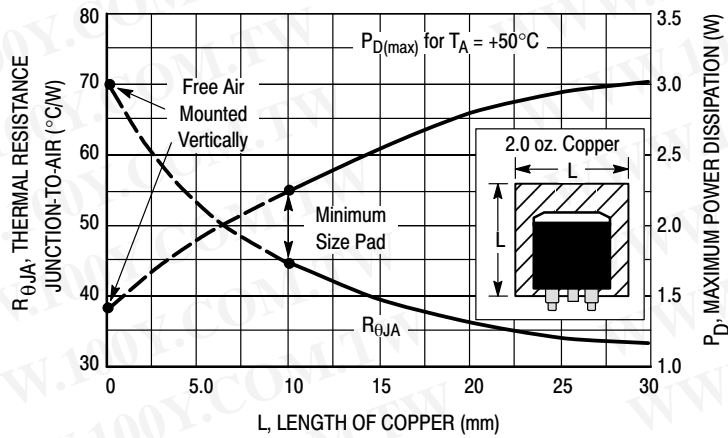

Figure 11. D<sup>2</sup>PAK Thermal Resistance and Maximum Power Dissipation versus P.C.B. Copper Length

### DEFINITIONS

**Line Regulation** – The change in output voltage for a change in the input voltage. The measurement is made under conditions of low dissipation or by using pulse techniques such that the average chip temperature is not significantly affected.

**Load Regulation** – The change in output voltage for a change in load current at constant chip temperature.

**Maximum Power Dissipation** – The maximum total device dissipation for which the regulator will operate within specifications.

**Input Bias Current** – That part of the input current that is not delivered to the load.

**Output Noise Voltage** – The rms AC voltage at the output, with constant load and no input ripple, measured over a specified frequency range.

**Long Term Stability** – Output voltage stability under accelerated life test conditions with the maximum rated voltage listed in the devices' electrical characteristics and maximum power dissipation.

勝特力材料 886-3-5753170  
 勝特力电子(上海) 86-21-34970699  
 勝特力电子(深圳) 86-755-83298787  
[Http://www.100y.com.tw](http://www.100y.com.tw)

# MC7900 Series

勝特力材料 886-3-5753170  
 勝特力电子(上海) 86-21-34970699  
 勝特力电子(深圳) 86-755-83298787  
[Http://www.100y.com.tw](http://www.100y.com.tw)

## ORDERING INFORMATION

Device	Nominal Output Voltage	Output Voltage Tolerance	Package	Operating Temperature Range	Shipping†
MC7905ACD2T	-5.0 V	2%	D <sup>2</sup> PAK	T <sub>J</sub> = 0°C to +125°C	50 Units/Rail
MC7905ACD2TG			D <sup>2</sup> PAK (Pb-Free)		50 Units/Rail
MC7905ACD2TR4			D <sup>2</sup> PAK		800 Tape & Reel
MC7905ACD2TR4G			D <sup>2</sup> PAK (Pb-Free)		800 Tape & Reel
MC7905ACT			TO-220		50 Units/Rail
MC7905ACTG			TO-220 (Pb-Free)		50 Units/Rail
MC7905BD2T		4%	D <sup>2</sup> PAK	T <sub>J</sub> = -40°C to +125°C	50 Units/Rail
MC7905BD2TG			D <sup>2</sup> PAK (Pb-Free)		50 Units/Rail
MC7905BD2TR4			D <sup>2</sup> PAK		800 Tape & Reel
MC7905BD2TR4G			D <sup>2</sup> PAK (Pb-Free)		800 Tape & Reel
MC7905BT			TO-220		50 Units/Rail
MC7905BTG			TO-220 (Pb-Free)		50 Units/Rail
MC7905CD2T			D <sup>2</sup> PAK	T <sub>J</sub> = 0°C to +125°C	50 Units/Rail
MC7905CD2TG			D <sup>2</sup> PAK (Pb-Free)		50 Units/Rail
MC7905CD2TR4			D <sup>2</sup> PAK		800 Tape & Reel
MC7905CD2TR4G			D <sup>2</sup> PAK (Pb-Free)		800 Tape & Reel
MC7905CT			TO-220		50 Units/Rail
MC7905CTG			TO-220 (Pb-Free)		50 Units/Rail
MC7905.2CT	-5.2 V	4%	TO-220	T <sub>J</sub> = 0°C to +125°C	50 Units/Rail
MC7905.2CTG			TO-220 (Pb-Free)		50 Units/Rail
MC7906CD2T	-6.0 V	4%	D <sup>2</sup> PAK	T <sub>J</sub> = 0°C to +125°C	50 Units/Rail
MC7906CD2TG			D <sup>2</sup> PAK (Pb-Free)		50 Units/Rail
MC7906CT			TO-220		50 Units/Rail
MC7906CTG			TO-220 (Pb-Free)		50 Units/Rail
MC7908ACT	-8.0 V	2%	TO-220	T <sub>J</sub> = 0°C to +125°C	50 Units/Rail
MC7908ACTG			TO-220 (Pb-Free)		50 Units/Rail
MC7908CD2T		4%	D <sup>2</sup> PAK	T <sub>J</sub> = 0°C to +125°C	50 Units/Rail
MC7908CD2TG			D <sup>2</sup> PAK (Pb-Free)		50 Units/Rail
MC7908CD2TR4			D <sup>2</sup> PAK		800 Tape & Reel
MC7908CD2TR4G			D <sup>2</sup> PAK (Pb-Free)		800 Tape & Reel
MC7908CT			TO-220		50 Units/Rail
MC7908CTG			TO-220 (Pb-Free)		50 Units/Rail

## MC7900 Series

Device	Nominal Output Voltage	Output Voltage Tolerance	Package	Operating Temperature Range	Shipping <sup>†</sup>
MC7912ACD2T	-12 V	2%	D <sup>2</sup> PAK	T <sub>J</sub> = 0°C to +125°C	50 Units/Rail
MC7912ACD2TG			D <sup>2</sup> PAK (Pb-Free)		50 Units/Rail
MC7912ACD2TR4			D <sup>2</sup> PAK		800 Tape & Reel
MC7912ACD2TR4G			D <sup>2</sup> PAK (Pb-Free)		800 Tape & Reel
MC7912ACT			TO-220		50 Units/Rail
MC7912ACTG			TO-220 (Pb-Free)		50 Units/Rail
MC7912BD2T		4%	D <sup>2</sup> PAK	T <sub>J</sub> = -40°C to +125°C	50 Units/Rail
MC7912BD2TG			D <sup>2</sup> PAK (Pb-Free)		50 Units/Rail
MC7912BD2TR4			D <sup>2</sup> PAK		800 Tape & Reel
MC7912BD2TR4G			D <sup>2</sup> PAK (Pb-Free)		800 Tape & Reel
MC7912BT			TO-220		50 Units/Rail
MC7912BTG			TO-220 (Pb-Free)		50 Units/Rail
MC7912CD2T			D <sup>2</sup> PAK	T <sub>J</sub> = 0°C to +125°C	50 Units/Rail
MC7912CD2TG			D <sup>2</sup> PAK (Pb-Free)		50 Units/Rail
MC7912CD2TR4			D <sup>2</sup> PAK		800 Tape & Reel
MC7912CD2TR4G			D <sup>2</sup> PAK (Pb-Free)		800 Tape & Reel
MC7912CT			TO-220		50 Units/Rail
MC7912CTG			TO-220 (Pb-Free)		50 Units/Rail
MC7915ACD2T	- 15 V	2%	D <sup>2</sup> PAK	T <sub>J</sub> = 0°C to +125°C	50 Units/Rail
MC7915ACD2TG			D <sup>2</sup> PAK (Pb-Free)		50 Units/Rail
MC7915ACT			TO-220		50 Units/Rail
MC7915ACTG			TO-220 (Pb-Free)		50 Units/Rail
MC7915BD2T		4%	D <sup>2</sup> PAK	T <sub>J</sub> = -40°C to +125°C	50 Units/Rail
MC7915BD2TG			D <sup>2</sup> PAK (Pb-Free)		50 Units/Rail
MC7915BT			TO-220		50 Units/Rail
MC7915BTG			TO-220 (Pb-Free)		50 Units/Rail
MC7915CD2T			D <sup>2</sup> PAK	T <sub>J</sub> = 0°C to +125°C	50 Units/Rail
MC7915CD2TG			D <sup>2</sup> PAK (Pb-Free)		50 Units/Rail
MC7915CD2TR4			D <sup>2</sup> PAK		800 Tape & Reel
MC7915CD2TR4G			D <sup>2</sup> PAK (Pb-Free)		800 Tape & Reel
MC7915CT			TO-220		50 Units/Rail
MC7915CTG			TO-220 (Pb-Free)		50 Units/Rail

## MC7900 Series

Device	Nominal Output Voltage	Output Voltage Tolerance	Package	Operating Temperature Range	Shipping†
MC7918CT	- 18 V	4%	TO-220	$T_J = 0^{\circ}\text{C}$ to $+125^{\circ}\text{C}$	50 Units/Rail
MC7918CTG			TO-220 (Pb-Free)		50 Units/Rail
MC7924BT	- 24 V	4%	TO-220	$T_J = -40^{\circ}\text{C}$ to $+125^{\circ}\text{C}$	50 Units/Rail
MC7924BTG			TO-220 (Pb-Free)		50 Units/Rail
MC7924CD2T			D <sup>2</sup> PAK	$T_J = 0^{\circ}\text{C}$ to $+125^{\circ}\text{C}$	50 Units/Rail
MC7924CD2TG			D <sup>2</sup> PAK (Pb-Free)		50 Units/Rail
MC7924CT			TO-220	50 Units/Rail	
MC7924CTG			TO-220 (Pb-Free)	50 Units/Rail	

†For information on tape and reel specifications, including part orientation and tape sizes, please refer to our Tape and Reel Packaging Specifications Brochure, BRD8011/D.

**勝特力材料 886-3-5753170**  
**勝特力电子(上海) 86-21-34970699**  
**勝特力电子(深圳) 86-755-83298787**  
**Http://www.100y.com.tw**

# MC7900 Series

## MARKING DIAGRAMS

TO-220  
T SUFFIX  
CASE 221AB

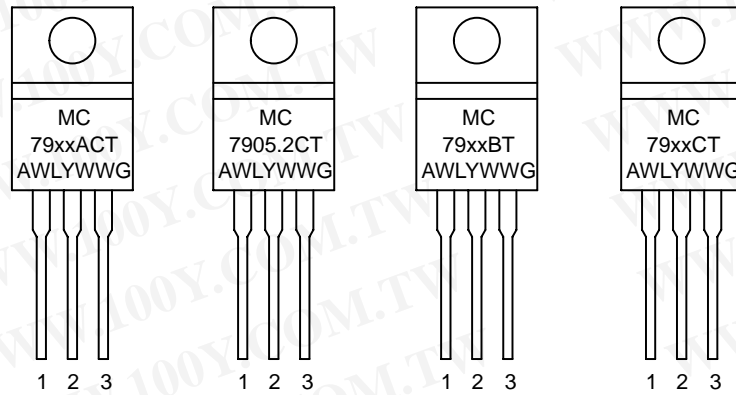

D<sup>2</sup>PAK  
D2T SUFFIX  
CASE 936

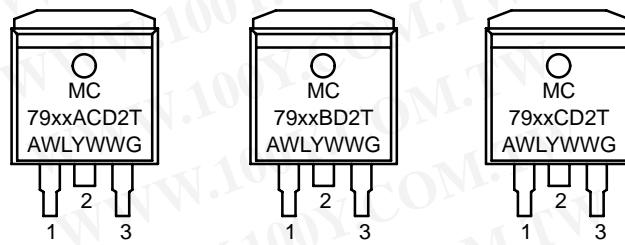

xx = Nominal Voltage  
A = Assembly Location  
WL = Wafer Lot  
Y = Year  
WW = Work Week  
G = Pb-Free Device

勝特力材料 886-3-5753170  
勝特力电子(上海) 86-21-34970699  
勝特力电子(深圳) 86-755-83298787  
[Http://www.100y.com.tw](http://www.100y.com.tw)



# MC7900 Series

## PACKAGE DIMENSIONS

TO-220, SINGLE GAUGE  
T SUFFIX  
CASE 221AB-01  
ISSUE O

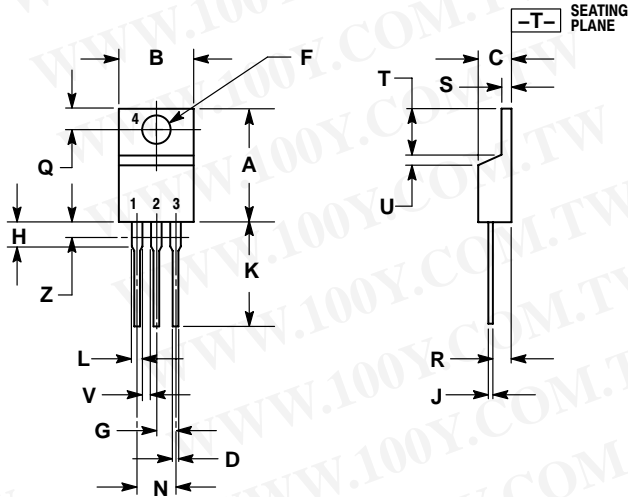

**NOTES:**

1. DIMENSIONING AND TOLERANCING PER ANSI Y14.5M, 1982.
2. CONTROLLING DIMENSION: INCH.
3. DIMENSION Z DEFINES A ZONE WHERE ALL BODY AND LEAD IRREGULARITIES ARE ALLOWED.

DIM	INCHES		MILLIMETERS	
	MIN	MAX	MIN	MAX
A	0.570	0.620	14.48	15.75
B	0.380	0.405	9.66	10.28
C	0.160	0.190	4.07	4.82
D	0.025	0.035	0.64	0.88
F	0.142	0.147	3.61	3.73
G	0.095	0.105	2.42	2.66
H	0.110	0.155	2.80	3.93
J	0.018	0.025	0.46	0.64
K	0.500	0.562	12.70	14.27
L	0.045	0.060	1.15	1.52
N	0.190	0.210	4.83	5.33
Q	0.100	0.120	2.54	3.04
R	0.080	0.110	2.04	2.79
S	0.020	0.055	0.508	1.39
T	0.235	0.255	5.97	6.47
U	0.000	0.050	0.00	1.27
V	0.045	---	1.15	---
Z	---	0.080	---	2.04

勝特力材料 886-3-5753170  
 勝特力电子(上海) 86-21-34970699  
 勝特力电子(深圳) 86-755-83298787  
[Http://www.100y.com.tw](http://www.100y.com.tw)

ON Semiconductor and are registered trademarks of Semiconductor Components Industries, LLC (SCILLC). SCILLC reserves the right to make changes without further notice to any products herein. SCILLC makes no warranty, representation or guarantee regarding the suitability of its products for any particular purpose, nor does SCILLC assume any liability arising out of the application or use of any product or circuit, and specifically disclaims any and all liability, including without limitation special, consequential or incidental damages. "Typical" parameters which may be provided in SCILLC data sheets and/or specifications can and do vary in different applications and actual performance may vary over time. All operating parameters, including "Typicals" must be validated for each customer application by customer's technical experts. SCILLC does not convey any license under its patent rights nor the rights of others. SCILLC products are not designed, intended, or authorized for use as components in systems intended for surgical implant into the body, or other applications intended to support or sustain life, or for any other application in which the failure of the SCILLC product could create a situation where personal injury or death may occur. Should Buyer purchase or use SCILLC products for any such unintended or unauthorized application, Buyer shall indemnify and hold SCILLC and its officers, employees, subsidiaries, affiliates, and distributors harmless against all claims, costs, damages, and expenses, and reasonable attorney fees arising out of, directly or indirectly, any claim of personal injury or death associated with such unintended or unauthorized use, even if such claim alleges that SCILLC was negligent regarding the design or manufacture of the part. SCILLC is an Equal Opportunity/Affirmative Action Employer. This literature is subject to all applicable copyright laws and is not for resale in any manner.

### PUBLICATION ORDERING INFORMATION

**LITERATURE FULFILLMENT:**  
 Literature Distribution Center for ON Semiconductor  
 P.O. Box 5163, Denver, Colorado 80217 USA  
**Phone:** 303-675-2175 or 800-344-3867 Toll Free USA/Canada  
**Fax:** 303-675-2176 or 800-344-3867 Toll Free USA/Canada  
**Email:** orderlit@onsemi.com

**N. American Technical Support:** 800-282-9855 Toll Free  
 USA/Canada  
**Europe, Middle East and Africa Technical Support:**  
 Phone: 421 33 790 2910  
**Japan Customer Focus Center**  
 Phone: 81-3-5773-3850

**ON Semiconductor Website:** [www.onsemi.com](http://www.onsemi.com)  
**Order Literature:** <http://www.onsemi.com/orderlit>  
 For additional information, please contact your local Sales Representative