

KA7552A/KA7553A

SMPS Controller

勝特力材料 886-3-5753170
 勝特力电子(上海) 86-21-34970699
 勝特力电子(深圳) 86-755-83298787
[Http://www.100y.com.tw](http://www.100y.com.tw)

Features

- Built-in drive circuits for direct connection power MOSFET ($I_O = \pm 1.5A$)
- Wide operating frequency range (5kHz ~ 600kHz)
- Pulse by pulse over current limiting
- Over load protection
- On/off control by external trigger
- Internal UVLO
- Low standby current (typ. 90uA)
- Soft start circuit

Description

The KA7552A/KA7553A are switching power control IC for wide operating frequency range. The internal circuits include pulse by pulse current limiting, protection, on/off control by external trigger, low standby current, soft start, and high current totempole output for driving a POWER MOSFET. Maximum duty of the KA7552A is 70% and the KA7553A is 46%. When duty is maximum, the input threshold voltage of pin2 & pin8 are not same in KA7552A and KA7553A.

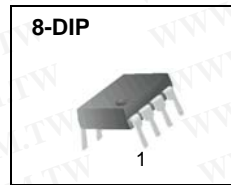

Internal Block Diagram

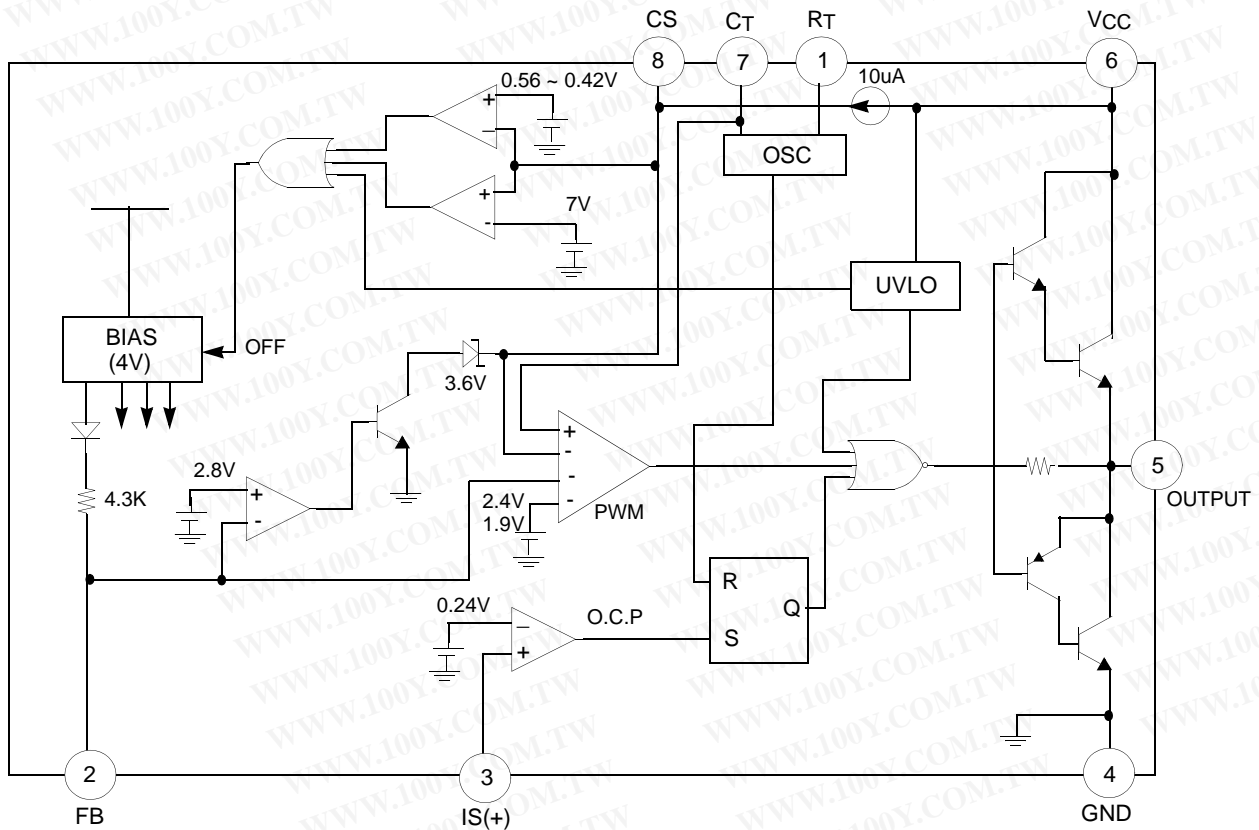

Absolute Maximum Ratings

Parameter	Symbol	Value	Unit
Supply voltage	VCC	30	V
Output current	IO	±1.5	A
Input voltage at overcurrent detection pin	VIN(IS)	-0.3 to 4	V
Input voltage at FB pin	VIN(FB)	4	V
Input current at CS pin	IIN(CS)	2	mA
Total power dissipation (Ta = 25°C)	PD	800	mW
Operating temperature	TOPR	-25 to 85	°C
Storage temperature range	TSTG	-65 to 150	°C
Junction temperature	Tj	+125	°C

Electrical Characteristics

(VCC = 18V, FOSC = 135kHz, TA = 25°C, unless otherwise specified)

Parameter	Symbol	Conditions	Min.	Typ.	Max.	Unit
OSCILLATOR SECTION						
Initial accuracy	FOSC	CT = 360pF, TJ = 25°C	125	135	145	kHz
Frequency variation 1	$\Delta F/\Delta V$	VCC = 10V to 30V	-	±1	±3	%
Frequency variation 2 ^(Note1)	$\Delta F/\Delta V$	TA = 25°C to 85°C	-	±1.5	-	%
Ramp high voltage	VRH	CT = 360pF, TJ = 25°C	2.80	3.08	3.30	V
Ramp low voltage	VRL	CT = 360pF, TJ = 25°C	0.6	0.9	1.2	V
Amplitude	VOSC	VPIN7, peak to peak	1.80	2.18	2.50	V
PULSE WIDTH MODULATION SECTION						
Input threshold voltage(pin2)	VTH(FBD)	Duty cycle = 0%	0.6	0.75	0.95	V
Input threshold voltage(pin2) ^(Note1)	VTH(FB1) (KA7552)	Duty cycle = Dmax 1	2.1	2.3	2.6	V
	VTH(FB2) (KA7553)	Duty cycle = Dmax 2	1.6	1.8	2.1	V
Max. duty cycle	D(Max1) (KA7552)	-	66	70	74	%
	D(Max2) (KA7553)	-	43	46	49	%
Source current(pin2)	ISOURCE(FB)	VPIN2 = 0V	-660	-800	-960	uA
OVERCURRENT LIMIT SECTION						
Input threshold voltage	VTH(IS)	-	0.21	0.24	0.27	V
Source current(pin3)	ISOURCE(IS)	VPIN3 = 0V	-300	-200	-100	uA
Deley time ^(Note1)	TD	-	-	150	-	ns
SOFT START SECTION						
Charging current	ICHG	VPIN8 = 0V	-15	-10	-5	uA
Input threshold voltage(pin8)	VTH(CSO)	-	0.7	0.9	1.1	V
Input threshold voltage(pin8) ^(Note1)	VTH(CS1) (KA7552)	Duty cycle = Dmax 1	2.2	2.4	2.6	V
	VTH(CS2) (KA7553)	Duty cycle = Dmax 2	1.7	1.9	2.1	V
LATCH MODE SHUTDOWN CIRCUIT SECTION						
Sink current(pin8)	ISINK(CS)	VPIN8 = 6V, VPIN2 = 1V	25	45	65	uA
Shutdown threshold voltage	VTH(SD,CS)	-	6.7	7.2	7.7	V
OVERLOAD SHUTDOWN SECTION						
Shutdown threshold voltage	VTH(SD,FB)	-	2.6	2.8	3.1	V

Electrical Characteristics (Continued)

(VCC = 18V, FOSC = 135kHz, TA = 25°C, unless otherwise specified)

Parameter	Symbol	Conditions	Min.	Typ.	Max.	Unit
UNDER VOLTAGE LOCKOUT SECTION						
Start-up threshold voltage	V _{TH(ST)}	-	15.5	16.0	16.5	V
Minimum operating voltage	V _{OPR(Min)}	-	8.20	8.70	9.20	V
Hysteresis	V _{HYS}	-	6.40	7.30	8.20	V
ON/OFF CONTROL SECTION						
Source current(pin8)	I _{SOURCE(CS)}	V _{PIN8} = 0V	-15	-10	-5	uA
On threshold voltage	V _{TH(ON)}	V _{PIN8} : OFF->ON	0.45	0.56	0.70	V
Off threshold voltage	V _{TH(OFF)}	V _{PIN8} : ON -> OFF	0.30	0.42	0.55	V
OUTPUT SECTION						
Low output voltage	V _{OL}	I _O = 100mA, V _{CC} = 18V	-	1.3	1.8	V
High output voltage	V _{OH}	I _O = -100mA, V _{CC} = 18V	16.0	16.5	18.0	V
Rise time ^(Note1)	T _R	No load	-	50	-	ns
Fall time ^(Note1)	T _F	No load	-	50	-	ns
OVERALL						
Stand-by current	I _{SB}	V _{CC} = 14V	-	90	150	uA
Operating current	I _{CC(OPR)}	V _{PIN2} = 0V	-	9	15	mA
Power supply current off	I _{CC(OFF)}	V _{PIN8} = 0V	-	1.1	1.8	mA
Power supply current shutdown	I _{CC(SD)}	V _{PIN8} = 7.6V	-	1.1	1.8	mA

Note :

- These parameters, although guaranteed, are not 100% tested in production.
- Recommend operating condition :
 - V_{cc(min)} = 12V
 - R_T = 3.3kΩ ~ 10kΩ
 - Oscillation frequency = 5kHz ~ 600kHz
 - Soft start capacitor(C_S) = 0.1uF ~ 1uF

Mechanical Dimensions

Package

Dimensions in millimeters

8-DIP

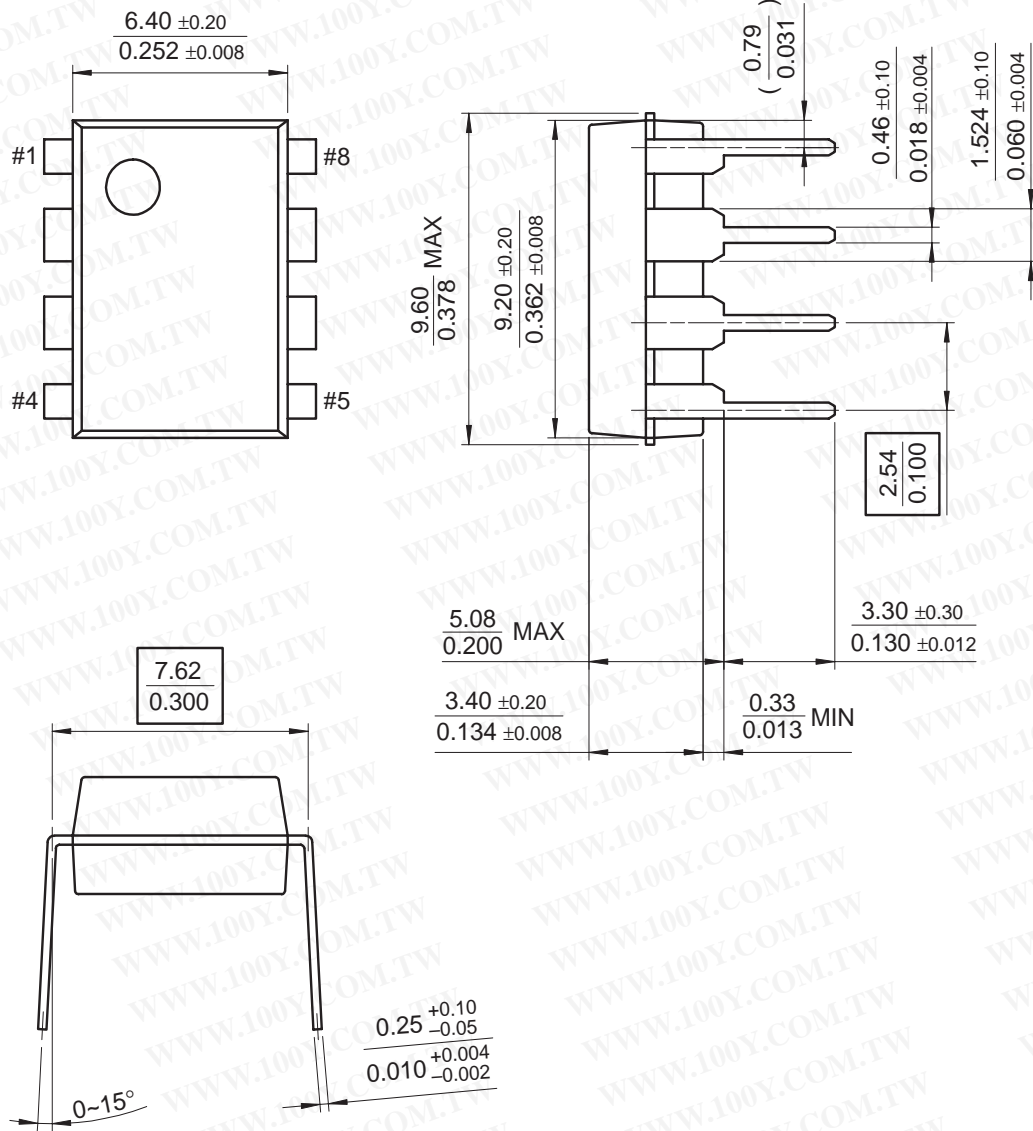

Ordering Information

Product Number	Package	Operating Temperature
KA7552A	8-DIP	-25 ~ +85°C
KA7553A		

勝特力材料 886-3-5753170
勝特力电子(上海) 86-21-34970699
勝特力电子(深圳) 86-755-83298787
[Http://www.100y.com.tw](http://www.100y.com.tw)

勝特力材料 886-3-5753170
勝特力电子(上海) 86-21-34970699
勝特力电子(深圳) 86-755-83298787
[Http://www.100y.com.tw](http://www.100y.com.tw)

DISCLAIMER

FAIRCHILD SEMICONDUCTOR RESERVES THE RIGHT TO MAKE CHANGES WITHOUT FURTHER NOTICE TO ANY PRODUCTS HEREIN TO IMPROVE RELIABILITY, FUNCTION OR DESIGN. FAIRCHILD DOES NOT ASSUME ANY LIABILITY ARISING OUT OF THE APPLICATION OR USE OF ANY PRODUCT OR CIRCUIT DESCRIBED HEREIN; NEITHER DOES IT CONVEY ANY LICENSE UNDER ITS PATENT RIGHTS, NOR THE RIGHTS OF OTHERS.

LIFE SUPPORT POLICY

FAIRCHILD'S PRODUCTS ARE NOT AUTHORIZED FOR USE AS CRITICAL COMPONENTS IN LIFE SUPPORT DEVICES OR SYSTEMS WITHOUT THE EXPRESS WRITTEN APPROVAL OF THE PRESIDENT OF FAIRCHILD SEMICONDUCTOR CORPORATION. As used herein:

1. Life support devices or systems are devices or systems which, (a) are intended for surgical implant into the body, or (b) support or sustain life, and (c) whose failure to perform when properly used in accordance with instructions for use provided in the labeling, can be reasonably expected to result in a significant injury of the user.
2. A critical component in any component of a life support device or system whose failure to perform can be reasonably expected to cause the failure of the life support device or system, or to affect its safety or effectiveness.