



FEATURES

Ultralow on resistance ($R_{DS(on)}$)

50 mΩ @ 3.6 V

55 mΩ @ 2.5 V

65 mΩ @ 1.8 V

100 mΩ @ 1.2 V

Input voltage range: 1.1 V to 3.6 V

1.1 A maximum continuous operating current

Low enable control logic threshold can be operated from 1.2 V to 3.3 V

Low 1 μA (typical) ground current @ 1.8 V

Low 4 μA (maximum) reverse current @ 3.6 V

Ultralow shutdown current: 0.7 μA (typical) @ 1.8 V

Reverse current blocking

Tiny 4-ball wafer level chip scale package (WLCSP)

1.0 mm × 1.0 mm, 0.5 mm pitch

Tiny 6-lead lead frame chip scale package (LFCSP)

2.0 mm × 2.0 mm × 0.55 mm, 0.65 mm pitch

APPLICATIONS

Mobile phones

Digital cameras and audio devices

GPS devices

Personal media players

Portable and battery-powered equipment

TYPICAL APPLICATIONS CIRCUIT

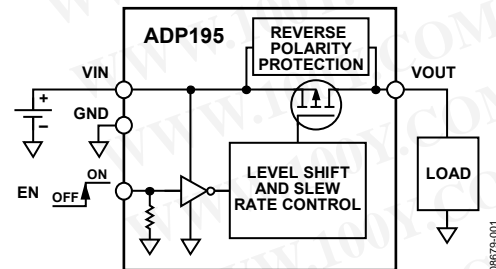

Figure 1.

GENERAL DESCRIPTION

The ADP195 is a high-side load switch designed for operation between 1.1 V to 3.6 V and protected against reverse current flow from output to input. This load switch provides power domain isolation helping extended power domain isolation. The device contains a low on-resistance, P-channel MOSFET that supports over 1.1 A of continuous current and minimizes power loss. The low 1 μA of quiescent current and ultralow shutdown current make the ADP195 ideal for battery-operated portable equipment. The built-in level shifter for enable logic makes the ADP195 compatible with many processors and GPIO controllers.

In addition to operating performance, the ADP195 occupies minimal printed circuit board (PCB) space with an area of less than 1.0 mm² and a height of 0.60 mm.

It is available in an ultrasmall 1 mm × 1 mm, 4-ball, 0.5 mm pitch WLCSP. A 6-lead 2 mm × 2 mm × 0.55 mm, 0.65 mm pitch LFCSP is also available.

勝特力材料 886-3-5753170
 勝特力电子(上海) 86-21-34970699
 勝特力电子(深圳) 86-755-83298787
[Http://www.100y.com.tw](http://www.100y.com.tw)

Rev. C

Information furnished by Analog Devices is believed to be accurate and reliable. However, no responsibility is assumed by Analog Devices for its use, nor for any infringements of patents or other rights of third parties that may result from its use. Specifications subject to change without notice. No license is granted by implication or otherwise under any patent or patent rights of Analog Devices. Trademarks and registered trademarks are the property of their respective owners.

TABLE OF CONTENTS

Features	1	Pin Configurations and Function Descriptions	5
Applications	1	Typical Performance Characteristics	6
Typical Applications Circuit	1	Theory of Operation	9
General Description	1	Applications Information	10
Revision History	2	Ground Current	10
Specifications	3	Enable Feature	10
Timing Diagram	3	Timing	11
Absolute Maximum Ratings	4	Outline Dimensions	12
Thermal Data	4	Ordering Guide	12
Thermal Resistance	4		
ESD Caution	4		

REVISION HISTORY

1/12—Rev. B to Rev. C

Changes to General Description Section	1
Changes to Table 2	4
Updated Outline Dimensions	12

2/11—Rev. A to Rev. B

Added 6-Lead LFCSP	Universal
Changes to Features, Applications, and General Description Sections	1
Added V_{IN} to V_{OUT} Resistance, LFCSP Parameter, Table 1	3
Changes to Table 2 and Table 3	4
Added Figure 4; Renumbered Sequentially	5
Added Table 5; Renumbered Sequentially	5
Added Figure 6, Figure 8, and Figure 10	6
Changes to Theory of Operation Section	9
Updated Outline Dimensions	12
Changes to Ordering Guide	12

7/10—Rev. 0 to Rev. A

Changes to Features and Applications Sections	1
Changed 10 μ A Ground Current to 1 μ A Ground Current in General Description Section	1
Changes to Table 2 and Thermal Resistance Section	4
Added Thermal Data Section	4

3/10—Revision 0: Initial Version

勝特力材料 886-3-5753170
 勝特力电子(上海) 86-21-34970699
 勝特力电子(深圳) 86-755-83298787
[Http://www.100y.com.tw](http://www.100y.com.tw)

SPECIFICATIONS

$V_{IN} = 1.8\text{ V}$, $V_{EN} = V_{IN}$, $I_{OUT} = 200\text{ mA}$, $T_A = 25^\circ\text{C}$, unless otherwise noted.

Table 1.

Parameter	Symbol	Conditions	Min	Typ	Max	Unit
INPUT VOLTAGE RANGE	V_{IN}	$T_J = -40^\circ\text{C}$ to $+85^\circ\text{C}$	1.1		3.6	V
EN INPUT						
EN Input Threshold	V_{IH}	$1.1\text{ V} \leq V_{IN} < 1.8\text{ V}$, $T_J = -40^\circ\text{C}$ to $+85^\circ\text{C}$ $1.8\text{ V} \leq V_{IN} \leq 3.6\text{ V}$, $T_J = -40^\circ\text{C}$ to $+85^\circ\text{C}$	0.29		1.0	V
EN Input Pull-Down Current	I_{EN}	$V_{IN} = 1.8\text{ V}$		500		nA
V_{IN} Shutdown Current		$V_{EN} = 0\text{ V}$, $V_{IN} = 0\text{ V}$, $V_{OUT} = 3.6\text{ V}$		-10		nA
REVERSE BLOCKING						
V_{OUT} Current		$V_{EN} = 0\text{ V}$, $V_{IN} = 0\text{ V}$, $V_{OUT} = 3.6\text{ V}$		4		μA
Hysteresis		$ V_{IN} - V_{OUT} $		75		mV
CURRENT						
Ground Current	I_{GND}	$V_{OUT} = 0$, includes V_{EN} pull-down and reverse blocking bias current, $V_{IN} = 3.6\text{ V}$, $T_J = -40^\circ\text{C}$ to $+85^\circ\text{C}$			10	μA
		$V_{OUT} = 0$, includes V_{EN} pull-down and reverse blocking bias current, $V_{IN} = 1.8\text{ V}$		1		μA
Off State Current	I_{OFF}	$V_{EN} = \text{GND}$ (includes reverse blocking bias current), $V_{OUT} = 0\text{ V}$ $V_{EN} = \text{GND}$, $T_J = -40^\circ\text{C}$ to $+85^\circ\text{C}$, $V_{OUT} = 0\text{ V}$		0.7		μA
					5	μA
V_{IN} to V_{OUT} RESISTANCE	$R_{DS(ON)}$					
WLCSP		$V_{IN} = 3.6\text{ V}$, $I_{LOAD} = 200\text{ mA}$, $V_{EN} = 3.6\text{ V}$ $V_{IN} = 2.5\text{ V}$, $I_{LOAD} = 200\text{ mA}$, $V_{EN} = 2.5\text{ V}$ $V_{IN} = 1.8\text{ V}$, $I_{LOAD} = 200\text{ mA}$, $V_{EN} = 1.8\text{ V}$ $V_{IN} = 1.8\text{ V}$, $I_{LOAD} = 200\text{ mA}$, $V_{EN} = 1.8\text{ V}$, $T_J = -40^\circ\text{C}$ to $+85^\circ\text{C}$ $V_{IN} = 1.5\text{ V}$, $I_{LOAD} = 200\text{ mA}$, $V_{EN} = 1.5\text{ V}$ $V_{IN} = 1.2\text{ V}$, $I_{LOAD} = 200\text{ mA}$, $V_{EN} = 1.2\text{ V}$		0.050		Ω
		$V_{IN} = 3.6\text{ V}$, $I_{LOAD} = 200\text{ mA}$, $V_{EN} = 3.6\text{ V}$ $V_{IN} = 2.5\text{ V}$, $I_{LOAD} = 200\text{ mA}$, $V_{EN} = 2.5\text{ V}$ $V_{IN} = 1.8\text{ V}$, $I_{LOAD} = 200\text{ mA}$, $V_{EN} = 1.8\text{ V}$ $V_{IN} = 1.8\text{ V}$, $I_{LOAD} = 200\text{ mA}$, $V_{EN} = 1.8\text{ V}$, $T_J = -40^\circ\text{C}$ to $+85^\circ\text{C}$ $V_{IN} = 1.5\text{ V}$, $I_{LOAD} = 200\text{ mA}$, $V_{EN} = 1.5\text{ V}$ $V_{IN} = 1.2\text{ V}$, $I_{LOAD} = 200\text{ mA}$, $V_{EN} = 1.2\text{ V}$		0.055		Ω
		$V_{IN} = 3.6\text{ V}$, $I_{LOAD} = 200\text{ mA}$, $V_{EN} = 3.6\text{ V}$ $V_{IN} = 2.5\text{ V}$, $I_{LOAD} = 200\text{ mA}$, $V_{EN} = 2.5\text{ V}$ $V_{IN} = 1.8\text{ V}$, $I_{LOAD} = 200\text{ mA}$, $V_{EN} = 1.8\text{ V}$ $V_{IN} = 1.8\text{ V}$, $I_{LOAD} = 200\text{ mA}$, $V_{EN} = 1.8\text{ V}$, $T_J = -40^\circ\text{C}$ to $+85^\circ\text{C}$ $V_{IN} = 1.5\text{ V}$, $I_{LOAD} = 200\text{ mA}$, $V_{EN} = 1.5\text{ V}$ $V_{IN} = 1.2\text{ V}$, $I_{LOAD} = 200\text{ mA}$, $V_{EN} = 1.2\text{ V}$		0.065		Ω
		$V_{IN} = 3.6\text{ V}$, $I_{LOAD} = 200\text{ mA}$, $V_{EN} = 3.6\text{ V}$ $V_{IN} = 2.5\text{ V}$, $I_{LOAD} = 200\text{ mA}$, $V_{EN} = 2.5\text{ V}$ $V_{IN} = 1.8\text{ V}$, $I_{LOAD} = 200\text{ mA}$, $V_{EN} = 1.8\text{ V}$ $V_{IN} = 1.8\text{ V}$, $I_{LOAD} = 200\text{ mA}$, $V_{EN} = 1.8\text{ V}$, $T_J = -40^\circ\text{C}$ to $+85^\circ\text{C}$ $V_{IN} = 1.5\text{ V}$, $I_{LOAD} = 200\text{ mA}$, $V_{EN} = 1.5\text{ V}$ $V_{IN} = 1.2\text{ V}$, $I_{LOAD} = 200\text{ mA}$, $V_{EN} = 1.2\text{ V}$		0.075	0.095	Ω
		$V_{IN} = 3.6\text{ V}$, $I_{LOAD} = 200\text{ mA}$, $V_{EN} = 3.6\text{ V}$ $V_{IN} = 2.5\text{ V}$, $I_{LOAD} = 200\text{ mA}$, $V_{EN} = 2.5\text{ V}$ $V_{IN} = 1.8\text{ V}$, $I_{LOAD} = 200\text{ mA}$, $V_{EN} = 1.8\text{ V}$ $V_{IN} = 1.8\text{ V}$, $I_{LOAD} = 200\text{ mA}$, $V_{EN} = 1.8\text{ V}$, $T_J = -40^\circ\text{C}$ to $+85^\circ\text{C}$ $V_{IN} = 1.5\text{ V}$, $I_{LOAD} = 200\text{ mA}$, $V_{EN} = 1.5\text{ V}$ $V_{IN} = 1.2\text{ V}$, $I_{LOAD} = 200\text{ mA}$, $V_{EN} = 1.2\text{ V}$		0.100		Ω
		$V_{IN} = 3.6\text{ V}$, $I_{LOAD} = 200\text{ mA}$, $V_{EN} = 3.6\text{ V}$ $V_{IN} = 2.5\text{ V}$, $I_{LOAD} = 200\text{ mA}$, $V_{EN} = 2.5\text{ V}$ $V_{IN} = 1.8\text{ V}$, $I_{LOAD} = 200\text{ mA}$, $V_{EN} = 1.8\text{ V}$ $V_{IN} = 1.8\text{ V}$, $I_{LOAD} = 200\text{ mA}$, $V_{EN} = 1.8\text{ V}$, $T_J = -40^\circ\text{C}$ to $+85^\circ\text{C}$ $V_{IN} = 1.5\text{ V}$, $I_{LOAD} = 200\text{ mA}$, $V_{EN} = 1.5\text{ V}$ $V_{IN} = 1.2\text{ V}$, $I_{LOAD} = 200\text{ mA}$, $V_{EN} = 1.2\text{ V}$		0.070		Ω
		$V_{IN} = 3.6\text{ V}$, $I_{LOAD} = 200\text{ mA}$, $V_{EN} = 3.6\text{ V}$ $V_{IN} = 2.5\text{ V}$, $I_{LOAD} = 200\text{ mA}$, $V_{EN} = 2.5\text{ V}$ $V_{IN} = 1.8\text{ V}$, $I_{LOAD} = 200\text{ mA}$, $V_{EN} = 1.8\text{ V}$ $V_{IN} = 1.8\text{ V}$, $I_{LOAD} = 200\text{ mA}$, $V_{EN} = 1.8\text{ V}$, $T_J = -40^\circ\text{C}$ to $+85^\circ\text{C}$ $V_{IN} = 1.5\text{ V}$, $I_{LOAD} = 200\text{ mA}$, $V_{EN} = 1.5\text{ V}$ $V_{IN} = 1.2\text{ V}$, $I_{LOAD} = 200\text{ mA}$, $V_{EN} = 1.2\text{ V}$		0.078		Ω
		$V_{IN} = 3.6\text{ V}$, $I_{LOAD} = 200\text{ mA}$, $V_{EN} = 3.6\text{ V}$ $V_{IN} = 2.5\text{ V}$, $I_{LOAD} = 200\text{ mA}$, $V_{EN} = 2.5\text{ V}$ $V_{IN} = 1.8\text{ V}$, $I_{LOAD} = 200\text{ mA}$, $V_{EN} = 1.8\text{ V}$ $V_{IN} = 1.8\text{ V}$, $I_{LOAD} = 200\text{ mA}$, $V_{EN} = 1.8\text{ V}$, $T_J = -40^\circ\text{C}$ to $+85^\circ\text{C}$ $V_{IN} = 1.5\text{ V}$, $I_{LOAD} = 200\text{ mA}$, $V_{EN} = 1.5\text{ V}$ $V_{IN} = 1.2\text{ V}$, $I_{LOAD} = 200\text{ mA}$, $V_{EN} = 1.2\text{ V}$		0.090		Ω
		$V_{IN} = 3.6\text{ V}$, $I_{LOAD} = 200\text{ mA}$, $V_{EN} = 3.6\text{ V}$ $V_{IN} = 2.5\text{ V}$, $I_{LOAD} = 200\text{ mA}$, $V_{EN} = 2.5\text{ V}$ $V_{IN} = 1.8\text{ V}$, $I_{LOAD} = 200\text{ mA}$, $V_{EN} = 1.8\text{ V}$ $V_{IN} = 1.8\text{ V}$, $I_{LOAD} = 200\text{ mA}$, $V_{EN} = 1.8\text{ V}$, $T_J = -40^\circ\text{C}$ to $+85^\circ\text{C}$ $V_{IN} = 1.5\text{ V}$, $I_{LOAD} = 200\text{ mA}$, $V_{EN} = 1.5\text{ V}$ $V_{IN} = 1.2\text{ V}$, $I_{LOAD} = 200\text{ mA}$, $V_{EN} = 1.2\text{ V}$		0.130		Ω
		$V_{IN} = 3.6\text{ V}$, $I_{LOAD} = 200\text{ mA}$, $V_{EN} = 3.6\text{ V}$ $V_{IN} = 2.5\text{ V}$, $I_{LOAD} = 200\text{ mA}$, $V_{EN} = 2.5\text{ V}$ $V_{IN} = 1.8\text{ V}$, $I_{LOAD} = 200\text{ mA}$, $V_{EN} = 1.8\text{ V}$ $V_{IN} = 1.8\text{ V}$, $I_{LOAD} = 200\text{ mA}$, $V_{EN} = 1.8\text{ V}$, $T_J = -40^\circ\text{C}$ to $+85^\circ\text{C}$ $V_{IN} = 1.5\text{ V}$, $I_{LOAD} = 200\text{ mA}$, $V_{EN} = 1.5\text{ V}$ $V_{IN} = 1.2\text{ V}$, $I_{LOAD} = 200\text{ mA}$, $V_{EN} = 1.2\text{ V}$		0.097		Ω
		$V_{IN} = 3.6\text{ V}$, $I_{LOAD} = 200\text{ mA}$, $V_{EN} = 3.6\text{ V}$ $V_{IN} = 2.5\text{ V}$, $I_{LOAD} = 200\text{ mA}$, $V_{EN} = 2.5\text{ V}$ $V_{IN} = 1.8\text{ V}$, $I_{LOAD} = 200\text{ mA}$, $V_{EN} = 1.8\text{ V}$ $V_{IN} = 1.8\text{ V}$, $I_{LOAD} = 200\text{ mA}$, $V_{EN} = 1.8\text{ V}$, $T_J = -40^\circ\text{C}$ to $+85^\circ\text{C}$ $V_{IN} = 1.5\text{ V}$, $I_{LOAD} = 200\text{ mA}$, $V_{EN} = 1.5\text{ V}$ $V_{IN} = 1.2\text{ V}$, $I_{LOAD} = 200\text{ mA}$, $V_{EN} = 1.2\text{ V}$		0.125		Ω
V_{OUT} TURN-ON DELAY TIME						
Turn-On Delay Time	t_{ON_DLY}	$V_{IN} = 1.8\text{ V}$, $I_{LOAD} = 200\text{ mA}$, $V_{EN} = 1.8\text{ V}$, $C_{LOAD} = 1\text{ }\mu\text{F}$ $V_{IN} = 3.6\text{ V}$, $I_{LOAD} = 200\text{ mA}$, $V_{EN} = 3.6\text{ V}$, $C_{LOAD} = 1\text{ }\mu\text{F}$		5		μs
				1.5		μs

TIMING DIAGRAM

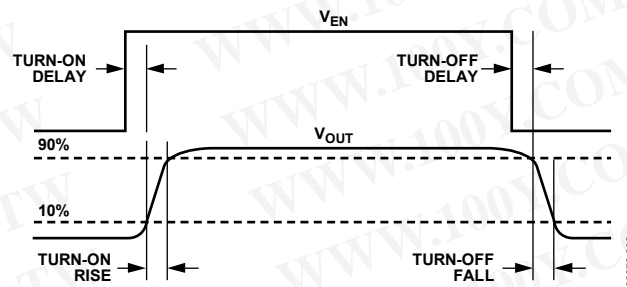

Figure 2. Timing Diagram

ABSOLUTE MAXIMUM RATINGS

Table 2.

Parameter	Rating
VIN, VIN1, VIN2 to GND	−0.3 V to +4.0 V
VOUT, VOUT1, VOUT2 to GND	−0.3 V to +4.0 V
EN to GND	−0.3 V to +4.0 V
Continuous Drain Current	
$T_A = 25^\circ\text{C}$	±2 A
$T_A = 85^\circ\text{C}$	±1.1 A
Continuous Diode Current	−50 mA
Storage Temperature Range	−65°C to +150°C
Operating Junction Temperature Range	−40°C to +125°C
Operating Ambient Temperature Range	−40°C to +85°C
Soldering Conditions	JEDEC J-STD-020

Stresses above those listed under Absolute Maximum Ratings may cause permanent damage to the device. This is a stress rating only; functional operation of the device at these or any other conditions above those indicated in the operational section of this specification is not implied. Exposure to absolute maximum rating conditions for extended periods may affect device reliability.

THERMAL DATA

Absolute maximum ratings apply individually only, not in combination. The ADP195 can be damaged when the junction temperature limits are exceeded. Monitoring ambient temperature does not guarantee that T_J is within the specified temperature limits. In applications with high power dissipation and poor PCB thermal resistance, the maximum ambient temperature may need to be derated.

In applications with moderate power dissipation and low PCB thermal resistance, the maximum ambient temperature can exceed the maximum limit as long as the junction temperature is within specification limits. The junction temperature (T_J) of the device is dependent on the ambient temperature (T_A), the power dissipation of the device (P_D), and the junction-to-ambient thermal resistance of the package (θ_{JA}).

Maximum junction temperature (T_J) is calculated from the ambient temperature (T_A) and power dissipation (P_D) using the formula

$$T_J = T_A + (P_D \times \theta_{JA})$$

Junction-to-ambient thermal resistance (θ_{JA}) of the package is based on modeling and calculation using a 4-layer board. The junction-to-ambient thermal resistance is highly dependent on the application and board layout. In applications where high maximum power dissipation exists, close attention to thermal board design is required. The value of θ_{JA} may vary, depending on PCB material, layout, and environmental conditions. The specified values of θ_{JA} are based on a 4-layer, 4 inch × 3 inch PCB. See JESD51-7 and JESD51-9 for detailed information regarding board construction. For additional information, see the AN-617 application note, *MicroCSP™ Wafer Level Chip Scale Package*.

Ψ_{JB} is the junction-to-board thermal characterization parameter with units of °C/W. Ψ_{JB} of the package is based on modeling and calculation using a 4-layer board. The JESD51-12 document, *Guidelines for Reporting and Using Electronic Package Thermal Information*, states that thermal characterization parameters are not the same as thermal resistances. Ψ_{JB} measures the component power flowing through multiple thermal paths rather than through a single path, as in thermal resistance (θ_{JB}). Therefore, Ψ_{JB} thermal paths include convection from the top of the package as well as radiation from the package, factors that make Ψ_{JB} more useful in real-world applications. Maximum junction temperature (T_J) is calculated from the board temperature (T_B) and the power dissipation (P_D) using the formula

$$T_J = T_B + (P_D \times \Psi_{JB})$$

See JESD51-8, JESD51-9, and JESD51-12 for more detailed information about Ψ_{JB} .

THERMAL RESISTANCE

θ_{JA} and Ψ_{JB} are specified for the worst-case conditions, that is, a device soldered in a circuit board for surface-mount packages.

Table 3. Thermal Resistance

Package Type	θ_{JA}	Ψ_{JB}	Unit
4-Ball, 0.5 mm Pitch WLCSP	260	58.4	°C/W
6-Lead, 2 mm × 2 mm LFCSP	72.1	24.0	°C/W

ESD CAUTION



ESD (electrostatic discharge) sensitive device. Charged devices and circuit boards can discharge without detection. Although this product features patented or proprietary protection circuitry, damage may occur on devices subjected to high energy ESD. Therefore, proper ESD precautions should be taken to avoid performance degradation or loss of functionality.

勝特力材料 886-3-5753170
 勝特力电子(上海) 86-21-34970699
 勝特力电子(深圳) 86-755-83298787
[Http://www.100y.com.tw](http://www.100y.com.tw)

PIN CONFIGURATIONS AND FUNCTION DESCRIPTIONS

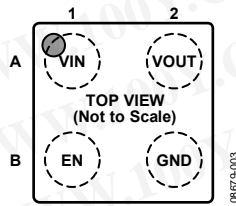
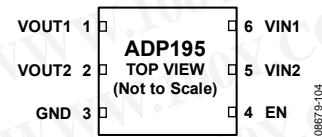

Figure 3. 4-Ball WLCSP Pin Configuration



NOTES

1. THE EXPOSED PAD MUST BE CONNECTED TO GND.

Figure 4. 6-Lead LFCSP Pin Configuration

Table 4. WLCSP Pin Function Descriptions

Pin No.	Mnemonic	Description
A1	VIN	Input Voltage.
A2	VOUT	Output Voltage.
B1	EN	Enable Input. Drive EN high to turn on the switch and drive EN low to turn off the switch.
B2	GND	Ground.

Table 5. LFCSP Pin Function Descriptions

Pin No.	Mnemonic	Description
1	VOUT1	Output Voltage. Connect VOUT1 and VOUT2 together.
2	VOUT2	Output Voltage. Connect VOUT1 and VOUT2 together.
3	GND	Ground.
4	EN	Enable Input. Drive EN high to turn on the switch and drive EN low to turn off the switch.
5	VIN2	Input Voltage. Connect VIN1 and VIN2 together.
6	VIN1	Input Voltage. Connect VIN1 and VIN2 together.
EP	EP	The exposed pad must be connected to ground.

勝特力材料 886-3-5753170
 勝特力电子(上海) 86-21-34970699
 勝特力电子(深圳) 86-755-83298787
[Http://www.100y.com.tw](http://www.100y.com.tw)

TYPICAL PERFORMANCE CHARACTERISTICS

$V_{IN} = 1.8\text{ V}$, $V_{EN} = V_{IN}$, $C_{IN} = C_{OUT} = 1\ \mu\text{F}$, $T_A = 25^\circ\text{C}$, unless otherwise noted.

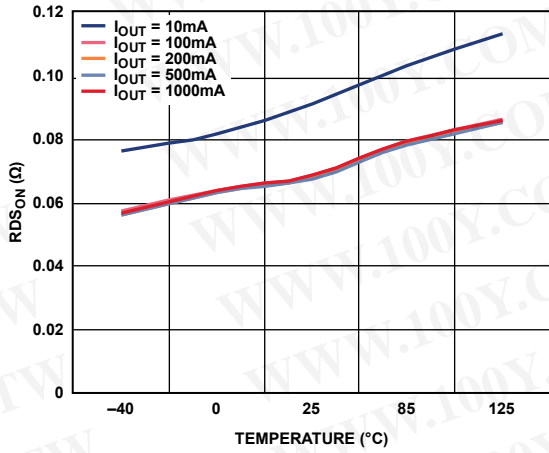

Figure 5. $R_{DS(on)}$ vs. Temperature, WLCSPP

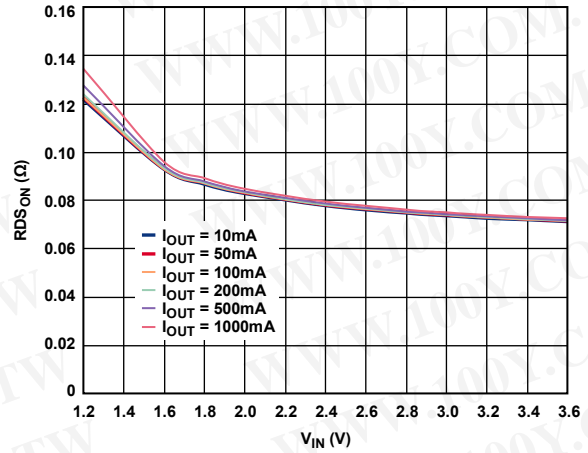

Figure 8. $R_{DS(on)}$ vs. Input Voltage (V_{IN}), LFCSP

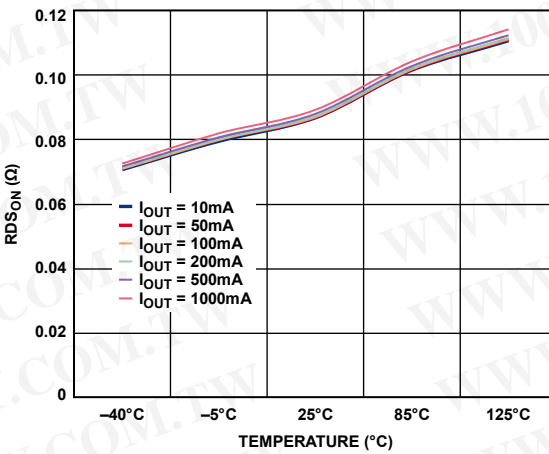

Figure 6. $R_{DS(on)}$ vs. Temperature, LFCSP

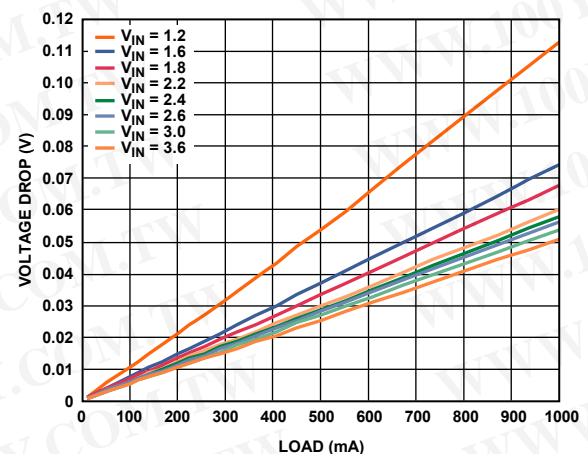

Figure 9. Voltage Drop vs. Load Current, WLCSPP

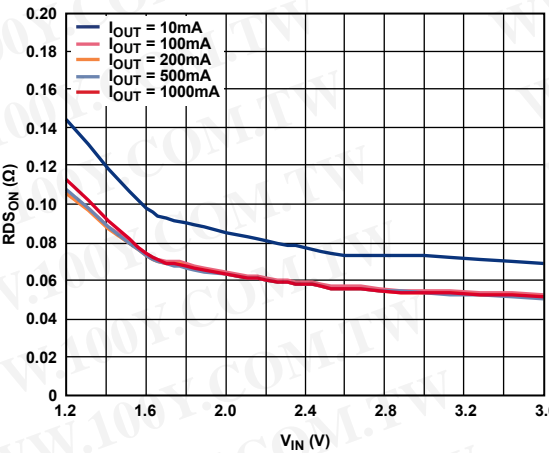

Figure 7. $R_{DS(on)}$ vs. Input Voltage (V_{IN}), WLCSPP

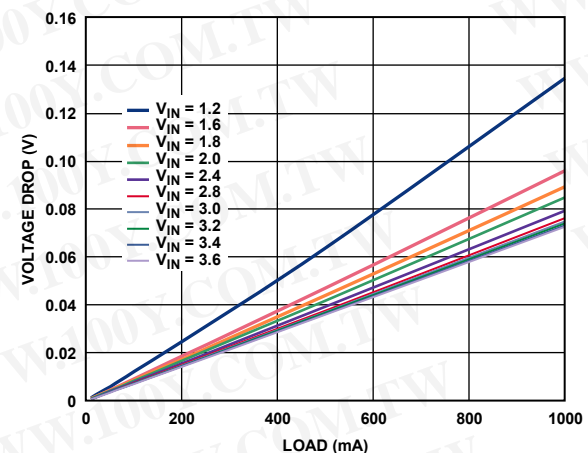

Figure 10. Voltage Drop vs. Load Current, LFCSP

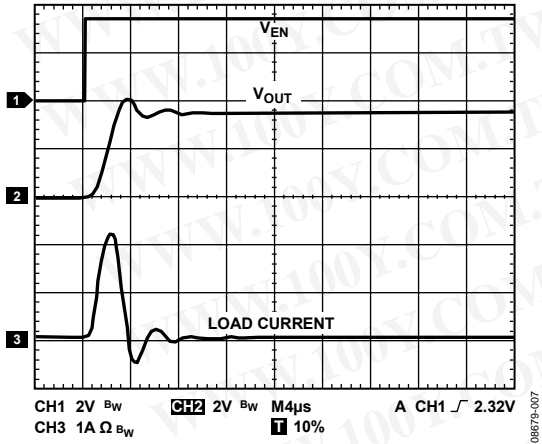

Figure 11. Typical Rise Time and Inrush Current, $V_{IN} = 3.6V$, No Load

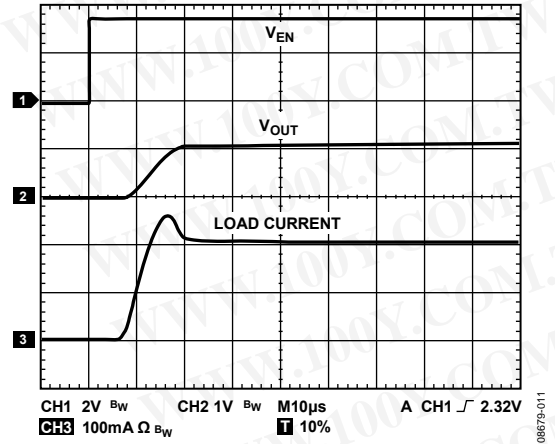

Figure 14. Typical Rise Time and Inrush Current, $V_{IN} = 1.2V$, Load = 200 mA

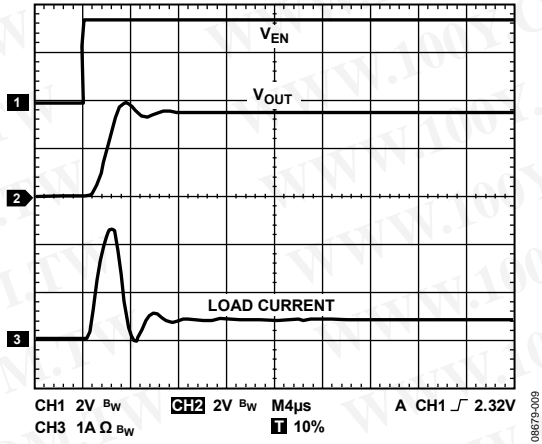

Figure 12. Typical Rise Time and Inrush Current, $V_{IN} = 3.6V$, Load = 200 mA

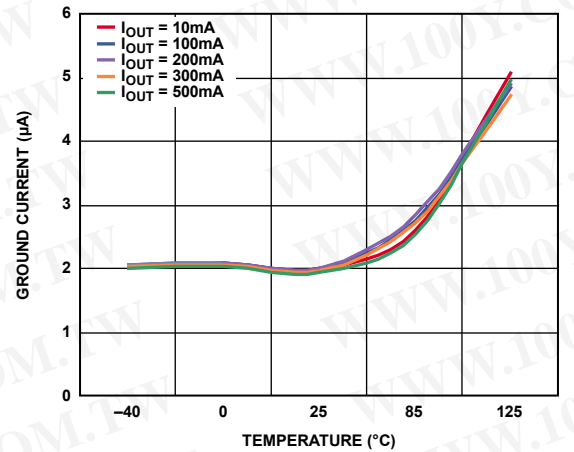

Figure 15. Ground Current vs. Temperature

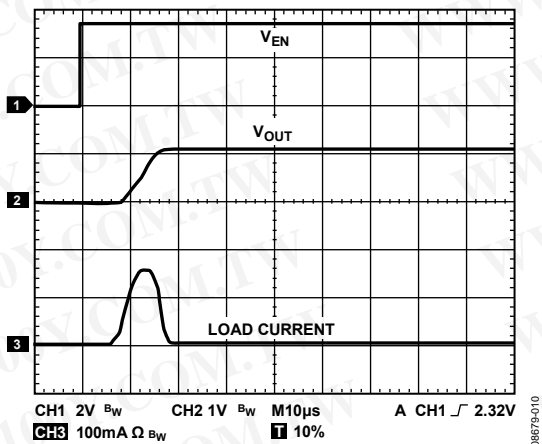

Figure 13. Typical Rise Time and Inrush Current, $V_{IN} = 1.2V$, No Load

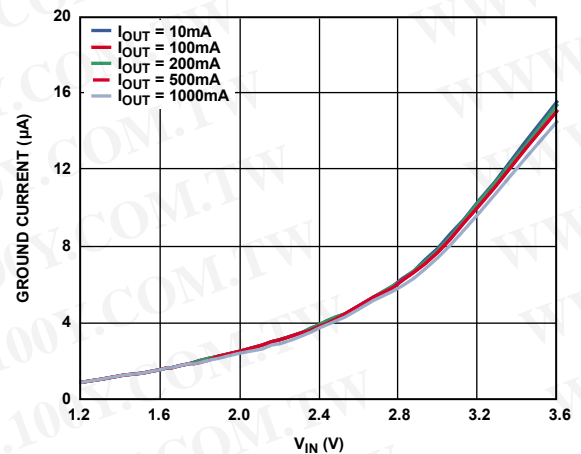

Figure 16. Ground Current vs. Input Voltage (V_{IN})

勝特力材料 886-3-5753170
 勝特力电子(上海) 86-21-34970699
 勝特力电子(深圳) 86-755-83298787
[Http://www.100y.com.tw](http://www.100y.com.tw)

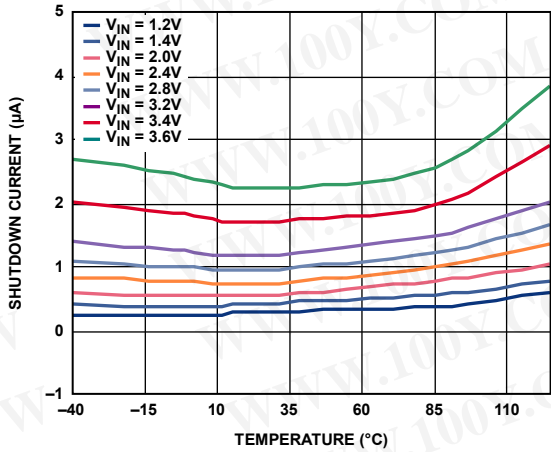

Figure 17. Shutdown Current vs. Temperature

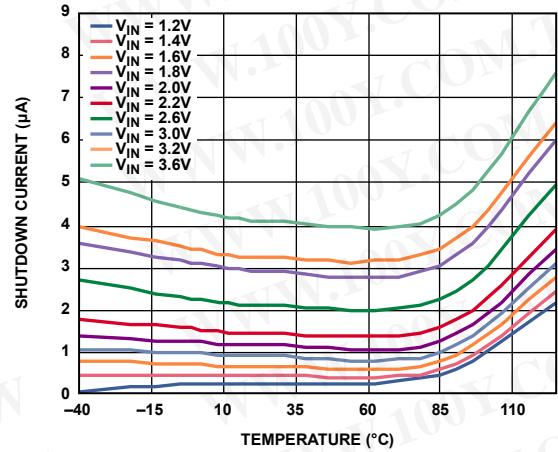

Figure 19. Reverse Output Shutdown Current vs. Temperature

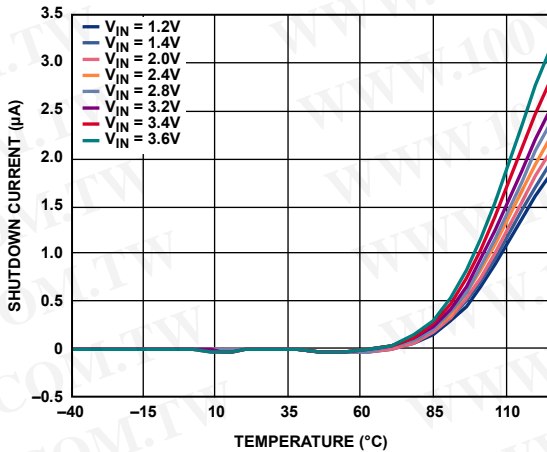

Figure 18. Reverse Input Shutdown Current vs. Temperature

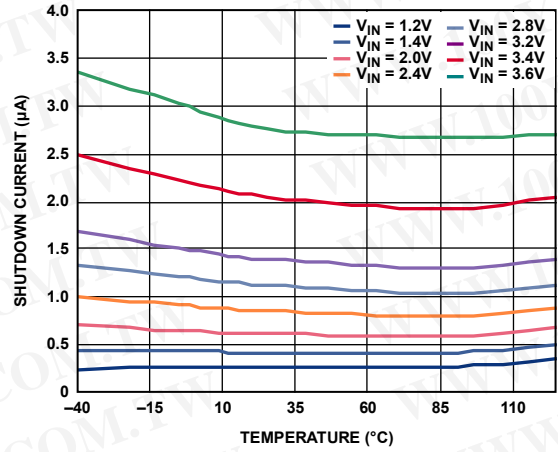

Figure 20. Reverse Shutdown Current vs. Temperature

勝特力材料 886-3-5753170
 勝特力电子(上海) 86-21-34970699
 勝特力电子(深圳) 86-755-83298787
[Http://www.100y.com.tw](http://www.100y.com.tw)

THEORY OF OPERATION

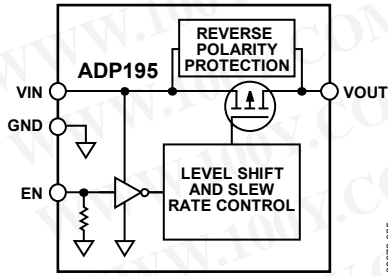

Figure 21. Functional Block Diagram

The ADP195 is a high-side PMOS load switch. It is designed for supply operation between 1.1 V to 3.6 V. The PMOS load switch is designed for low on resistance, 65 m Ω at $V_{IN} = 1.8$ V and supports greater than 1 A of continuous current. It is a low

quiescent current device with a nominal 4 M Ω pull-down resistor on its enable pin (EN).

The reverse current protection circuitry prevents current flow backward through the ADP195 when the output voltage is greater than the input voltage. A comparator senses the difference between the input and output voltages. When the difference between the input voltage and output voltage exceeds 75 mV, the body of the pFET is switched to V_{OUT} and is turned off or opened; that is, the gate is connected to V_{OUT} .

The packaging is a space-saving 1.0 mm \times 1.0 mm, 4-ball WLCSP. The ADP195 is also available in a 2 mm \times 2 mm \times 0.55 mm, 0.65 mm pitch LFCSP.

勝特力材料 886-3-5753170
 勝特力电子(上海) 86-21-34970699
 勝特力电子(深圳) 86-755-83298787
[Http://www.100y.com.tw](http://www.100y.com.tw)

APPLICATIONS INFORMATION

GROUND CURRENT

The major source for ground current in the ADP195 is an internal 4 MΩ pull-down on the enable pin. Figure 22 shows the typical ground current when $V_{EN} = V_{IN}$ and varies from 1.2 V to 3.6 V.

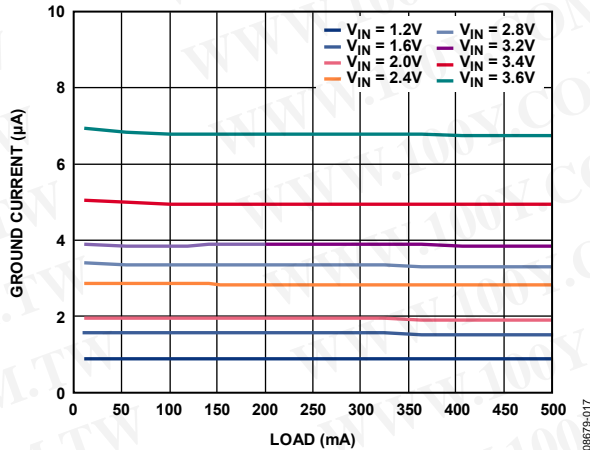

Figure 22. Ground Current vs. Load Current

As shown in Figure 23, an increase in quiescent current can occur when $V_{EN} \neq V_{IN}$. This is caused by the CMOS logic nature of the level shift circuitry as it translates an V_{EN} signal ≥ 1.2 V to a logic high. This increase is a function of the $V_{IN} - V_{EN}$ delta.

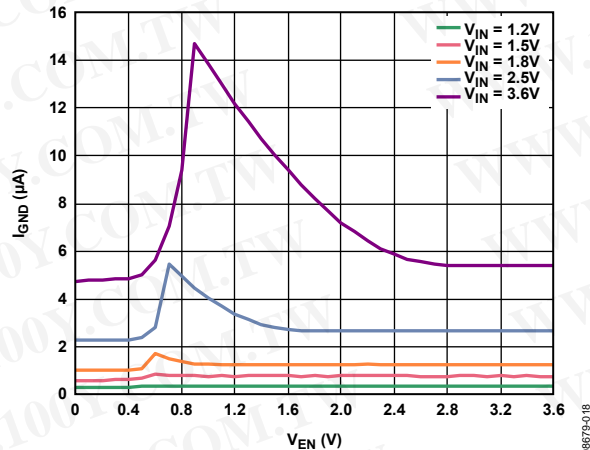

Figure 23. Typical Ground Current when $V_{EN} \neq V_{IN}$

勝特力材料 886-3-5753170
 勝特力电子(上海) 86-21-34970699
 勝特力电子(深圳) 86-755-83298787
[Http://www.100y.com.tw](http://www.100y.com.tw)

ENABLE FEATURE

The ADP195 uses the EN pin to enable and disable the V_{OUT} pin under normal operating conditions. As shown in Figure 24, when a rising voltage on V_{EN} crosses the active threshold, V_{OUT} turns on. When a falling voltage on V_{EN} crosses the inactive threshold, V_{OUT} turns off.

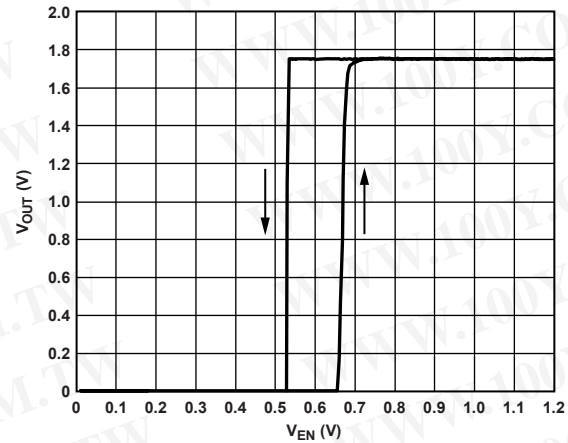

Figure 24. Typical EN Operation

As shown in Figure 24, the EN pin has hysteresis built in. This prevents on/off oscillations that can occur due to noise on the EN pin as it passes through the threshold points.

The EN pin active/inactive thresholds derive from the V_{IN} voltage; therefore, these thresholds vary with the changing input voltage. Figure 25 shows the typical EN active/inactive thresholds when the input voltage varies from 1.2 V to 3.6 V.

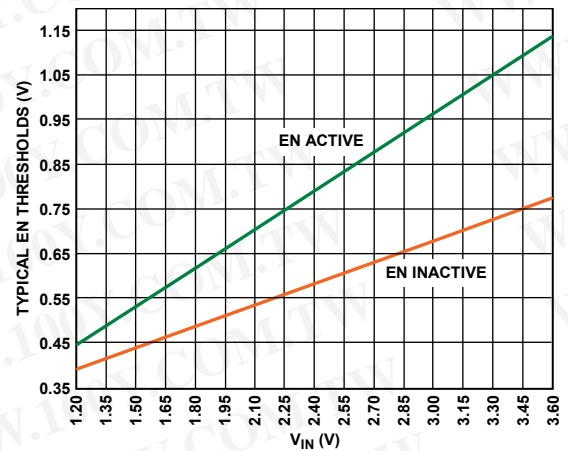

Figure 25. Typical EN Thresholds vs. Input Voltage (V_{IN})

TIMING

Turn-on delay is defined as the delta between the time that V_{EN} reaches $>1.2V$ until V_{OUT} rises to $\sim 10\%$ of its final value. The ADP195 includes circuitry to have typical $5\mu s$ turn-on delay at $3.6V$ V_{IN} to limit the V_{IN} inrush current. As shown in Figure 26, the turn-on delay is dependent on the input voltage.

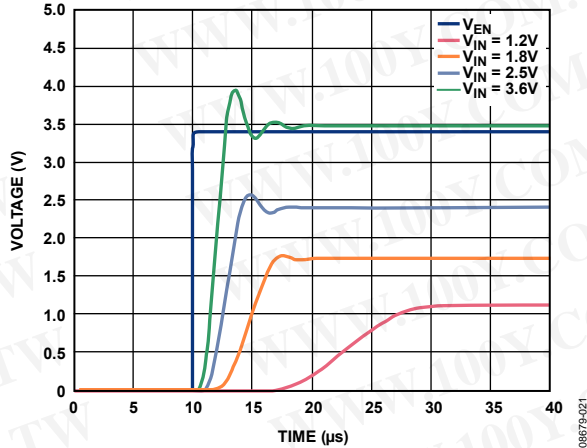

Figure 26. Typical Turn-On Delay Time with Varying Input Voltage

The rise time is defined as the delta between the time from 10% to 90% of V_{OUT} reaching its final value. It is dependent on the RC time constant where $C = \text{load capacitance } (C_{LOAD})$ and $R = R_{DS(ON)} || R_{LOAD}$. Because $R_{DS(ON)}$ is usually smaller than R_{LOAD} , an adequate approximation for RC is $R_{DS(ON)} \times C_{LOAD}$. An input or load capacitor is not needed for the ADP195; however, capacitors can be used to suppress noise on the board. If significant load capacitance is connected, inrush current is a concern.

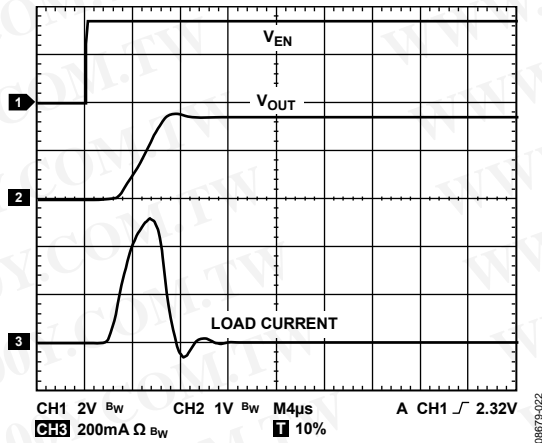

Figure 27. Typical Rise Time and Inrush Current, $C_{LOAD} = 1\mu F, V_{IN} = 1.8V, \text{No Load}$

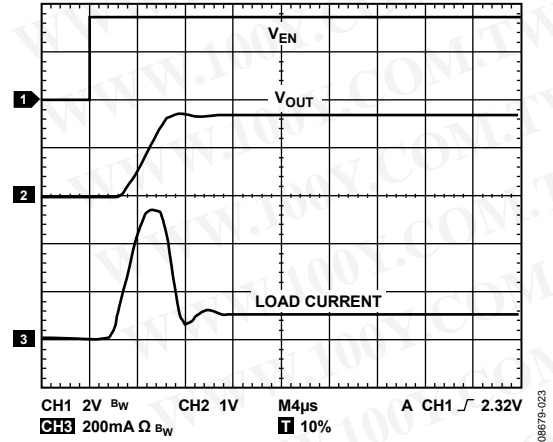

Figure 28. Typical Rise Time and Inrush Current, $C_{LOAD} = 1\mu F, V_{IN} = 1.8V, \text{Load} = 200mA$

The turn-off time is defined as the delta between the time from 90% to 10% of V_{OUT} reaching its final value. It is also dependent on the RC time constant.

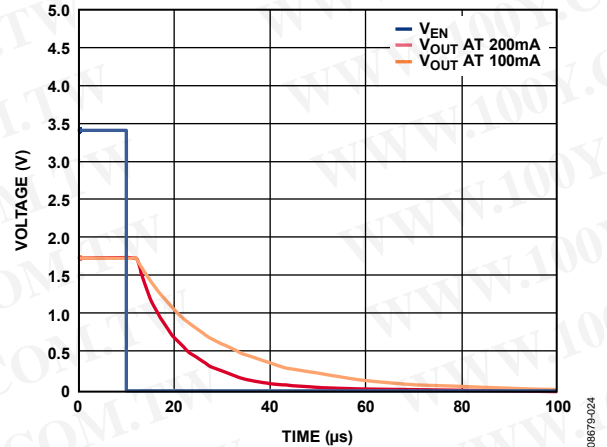

Figure 29. Typical Turn-Off Time

勝特力材料 886-3-5753170
 勝特力电子(上海) 86-21-34970699
 勝特力电子(深圳) 86-755-83298787
[Http://www.100y.com.tw](http://www.100y.com.tw)

OUTLINE DIMENSIONS

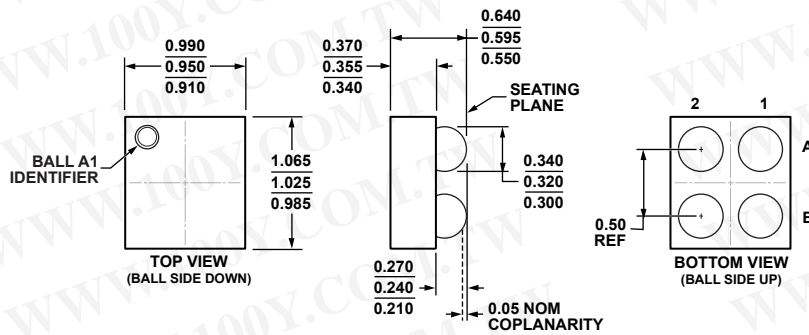

Figure 30. 4-Ball Wafer Level Chip Scale Package [WLCSP] (CB-4-4)

Dimensions shown in millimeters

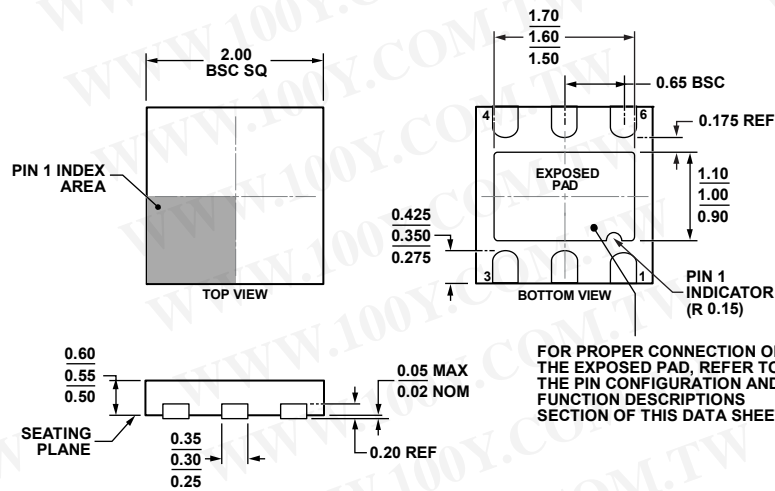

Figure 31. 6-Lead Lead Frame Chip Scale Package [LFCSP_UD] 2.00 x 2.00 mm Body, Ultra Thin, Dual Lead (CP-6-3)

Dimensions shown in millimeters

ORDERING GUIDE

Model ¹	Temperature Range	Package Description	Package Option	Branding
ADP195ACBZ-R7	-40°C to +85°C	4-Ball Wafer Level Chip Scale Package [WLCSP]	CB-4-4	5Y
ADP195ACPZ-R7	-40°C to +85°C	6-Lead Lead Frame Chip Scale Package [LFCSP_UD]	CP-6-3	LJ6
ADP195-EVALZ		Evaluation Board		
ADP195-CP-EVALZ		Evaluation Board		

¹ Z = RoHS Compliant Part.