



FEATURES

- Fast access time : 10/12/15 ns (max.)
- Low operating power consumption : 100 mA (typical)
- Single 5V power supply
- All inputs and outputs TTL compatible
- Fully static operation
- Three state outputs
- Package : 32-pin 300 mil skinny PDIP
32-pin 300 mil SOJ
32-pin 8 x 20mm TSOP-1
32-pin 8 x 13.4mm STSOP

GENERAL DESCRIPTION

The UT611024 is a 1,048,576-bit high-speed CMOS static random access memory organized as 131,072 words by 8 bits. It is fabricated using high performance, high reliability CMOS technology.

The UT611024 is designed for high-speed system applications. It is particularly suited for use in high-density high-speed system applications.

The UT611024 operates from a single 5V power supply and all inputs and outputs are fully TTL compatible.

FUNCTIONAL BLOCK DIAGRAM

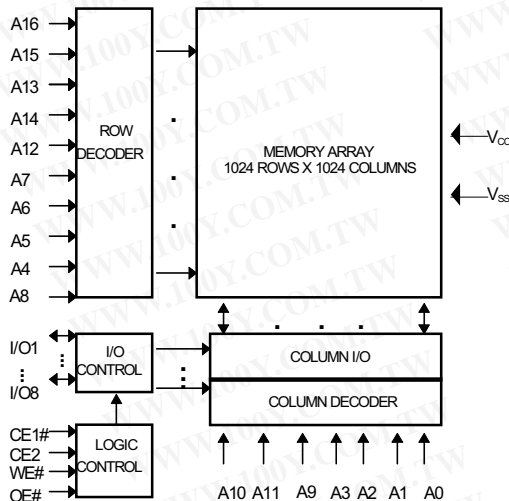

PIN CONFIGURATION

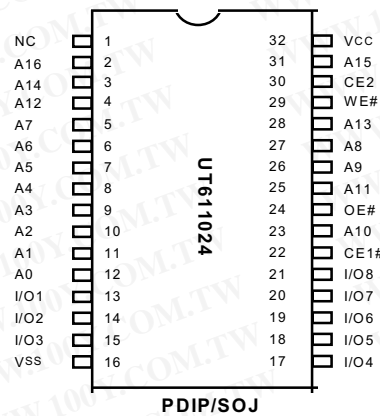

PIN DESCRIPTION

SYMBOL	DESCRIPTION
A0 - A16	Address Inputs
I/O1 - I/O8	Data Inputs/Outputs
CE1#,CE2	Chip Enable 1, 2 Inputs
WE#	Write Enable Input
OE#	Output Enable Input
V _{CC}	Power Supply
V _{SS}	Ground
NC	No Connection

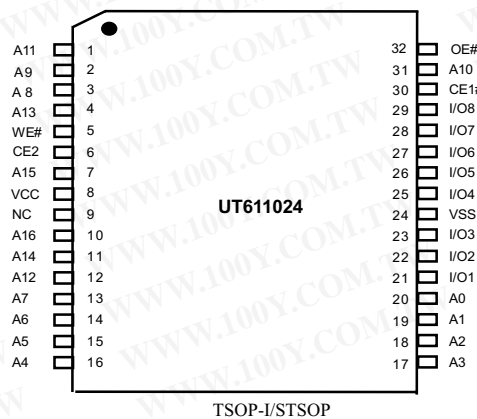

勝特力材料 886-3-5753170
勝特力电子(上海) 86-21-34970699
勝特力电子(深圳) 86-755-83298787
[Http://www.100y.com.tw](http://www.100y.com.tw)

**ABSOLUTE MAXIMUM RATINGS***

PARAMETER	SYMBOL	RATING	UNIT
Terminal Voltage with Respect to V _{ss}	VTERM	-0.5 to +7.0	V
Operating Temperature	TA	0 to +70	°C
Storage Temperature	TSTG	-65 to +150	°C
Power Dissipation	P _d	1	W
DC Output Current	I _{OUT}	50	mA
Soldering Temperature (under 10 sec)	T _{solder}	260	°C

*Stress greater than those listed under "Absolute Maximum Ratings" may cause permanent damage to the device. This

is a stress rating only and functional operation of the device or any other conditions above those indicated in the

operational sections of this specification is not implied. Exposure to the absolute maximum rating conditions for

extended period may affect device reliability.

TRUTH TABLE

MODE	CE1#	CE2	OE#	WE#	I/O OPERATION	SUPPLY CURRENT
Standby	H	X	X	X	High - Z	ISB, ISB1
Standby	X	L	X	X	High - Z	ISB, ISB1
Output Disable	L	H	H	H	High - Z	ICC
Read	L	H	L	H	DOUT	ICC
Write	L	H	X	L	DIN	ICC

Note: H = V_{IH}, L = V_{IL}, X = Don't care.

DC ELECTRICAL CHARACTERISTICS (VCC = 5V±10%, TA = 0°C to 70°C)

PARAMETER	SYMBOL	TEST CONDITION	MIN.	MAX.	UNIT	
Input High Voltage	V _{IH}		2.2	VCC+0.5	V	
Input Low Voltage	V _{IL}		- 0.5	0.8	V	
Input Leakage Current	I _{LI}	V _{SS} ≤ V _{IN} ≤ V _{CC}	- 1	1	μA	
Output Leakage Current	I _{LO}	V _{SS} ≤ V _{I/O} ≤ V _{CC} CE1# = V _{IH} or CE2 = V _{IL} or OE# = V _{IH} or WE# = V _{IL}	- 1	1	μA	
Output High Voltage	V _{OH}	I _{OH} = - 4mA	2.4	-	V	
Output Low Voltage	V _{OL}	I _{OL} = 8mA	-	0.4	V	
Operating Power Supply Current	ICC	CE1# = V _{IL} , CE2 = V _{IH} I _{I/O} = 0mA, Cycle=Min.	- 10	-	180	mA
			- 12	-	160	mA
			- 15	-	140	mA
Standby Power Supply Current	ISB	CE1# = V _{IH} or CE2 = V _{IL}	-	30	mA	
	ISB1	CE1# ≥ VCC-0.2V or CE2 ≤ 0.2V	-	5	mA	

勝特力材料 886-3-5753170
 勝特力电子(上海) 86-21-34970699
 勝特力电子(深圳) 86-755-83298787
[Http://www.100y.com.tw](http://www.100y.com.tw)

**CAPACITANCE** (TA=25°C, f=1.0MHz)

PARAMETER	SYMBOL	MIN.	MAX.	UNIT
Input Capacitance	CIN	-	8	pF
Input/Output Capacitance	CI/O	-	10	pF

Note : These parameters are guaranteed by device characterization, but not production tested.

AC TEST CONDITIONS

Input Pulse Levels	0V to 3.0V
Input Rise and Fall Times	5ns
Input and Output Timing Reference Levels	1.5V
Output Load	CL=30pF, IOH/IOL=-4mA/8mA

AC ELECTRICAL CHARACTERISTICS (VCC = 5V±10%, TA = 0°C to 70°C)**(1) READ CYCLE**

PARAMETER	SYMBOL	UT611024-10		UT611024-12		UT611024-15		UNIT
		MIN.	MAX.	MIN.	MAX.	MIN.	MAX.	
Read Cycle Time	tRC	10	-	12	-	15	-	ns
Address Access Time	tAA	-	10	-	12	-	15	ns
Chip Enable Access Time	tACE1, tACE1	-	10	-	12	-	15	ns
Output Enable Access Time	tOE	-	5	-	6	-	7	ns
Chip Enable to Output in Low Z	tCLZ1*, tCLZ2*	2	-	3	-	4	-	ns
Output Enable to Output in Low Z	tOLZ*	0	-	0	-	0	-	ns
Chip Disable to Output in High Z	tCHZ1*, tCHZ2*	-	5	-	6	-	7	ns
Output Disable to Output in High Z	tOHZ*	-	5	-	6	-	7	ns
Output Hold from Address Change	tOH	3	-	3	-	3	-	ns

(2) WRITE CYCLE

PARAMETER	SYMBOL	UT611024-10		UT611024-12		UT611024-15		UNIT
		MIN.	MAX.	MIN.	MAX.	MIN.	MAX.	
Write Cycle Time	tWC	10	-	12	-	15	-	ns
Address Valid to End of Write	tAW	8	-	10	-	12	-	ns
Chip Enable to End of Write	tCW1, tCW2	8	-	10	-	12	-	ns
Address Set-up Time	tAS	0	-	0	-	0	-	ns
Write Pulse Width	tWP	8	-	9	-	10	-	ns
Write Recovery Time	tWR	0	-	0	-	0	-	ns
Data to Write Time Overlap	tDW	6	-	7	-	8	-	ns
Data Hold from End of Write Time	tDH	0	-	0	-	0	-	ns
Output Active from End of Write	tOW*	2	-	3	-	4	-	ns
Write to Output in High Z	tWHZ*	-	6	-	7	-	8	ns

*These parameters are guaranteed by device characterization, but not production tested.

勝特力材料 886-3-5753170
 勝特力电子(上海) 86-21-34970699
 勝特力电子(深圳) 86-755-83298787
[Http://www.100y.com.tw](http://www.100y.com.tw)



TIMING WAVEFORMS

READ CYCLE 1 (Address Controlled) (1,2,4)

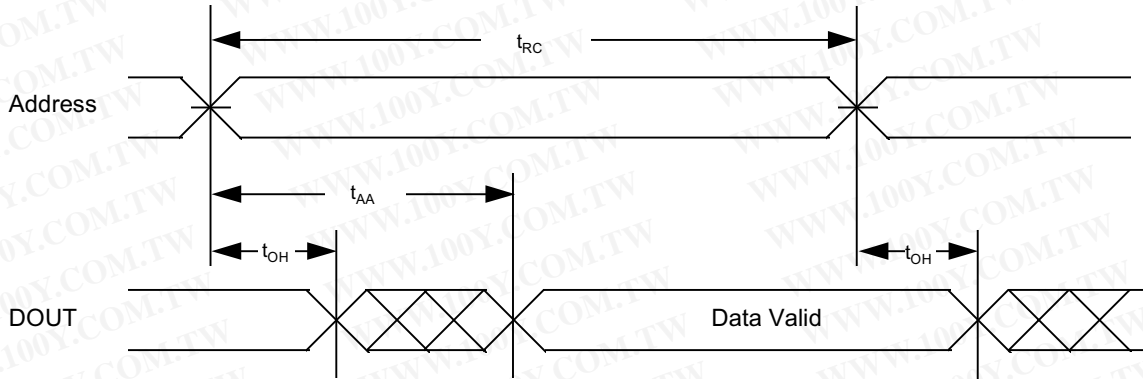

READ CYCLE 2 (CE#, CE2 and OE# Controlled) (1,3,5,6)

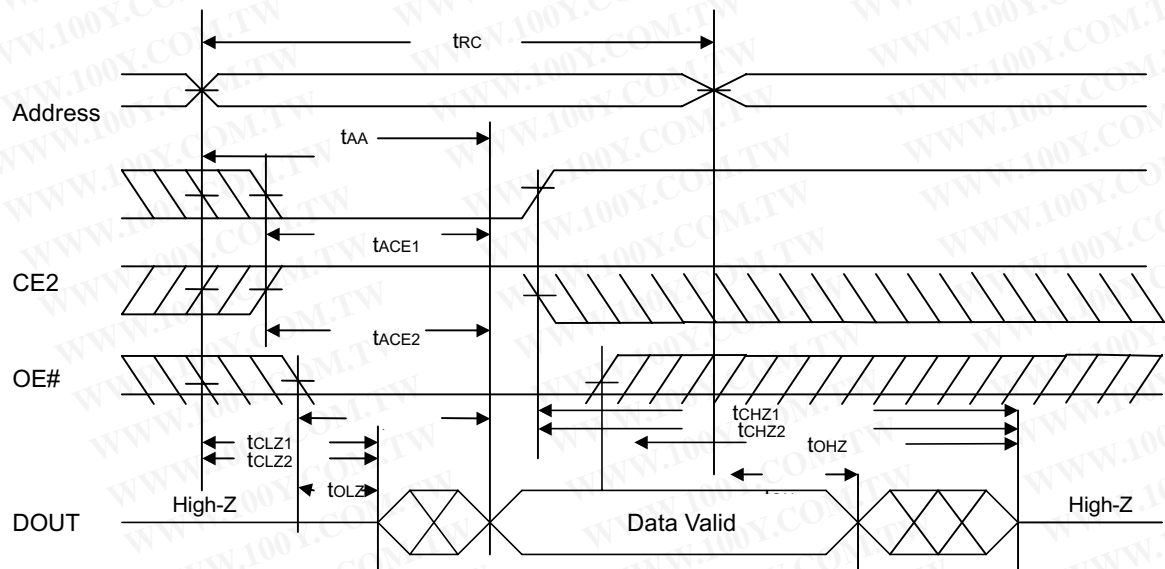

Notes :

1. WE# is HIGH for read cycle.
2. Device is continuously selected CE1#=VIL and CE2=VIH.
3. Address must be valid prior to or coincident with CE1# and CE2 transition; otherwise tAA is the limiting parameter.
4. OE# is low.
5. tCLZ1, tCLZ2, tOLZ, tCHZ1, tCHZ2 and tOHZ are specified with CL=5pF. Transition is measured ±500mV from steady state.
6. At any given temperature and voltage condition, tCHZ1 is less than tCLZ1, tCHZ2 is less than tCLZ2, tOHZ is less than tOLZ.

勝特力材料 886-3-5753170
 勝特力电子(上海) 86-21-34970699
 勝特力电子(深圳) 86-755-83298787
[Http://www.100y.com.tw](http://www.100y.com.tw)



WRITE CYCLE 1 (WE# Controlled) (1,2,3,5)

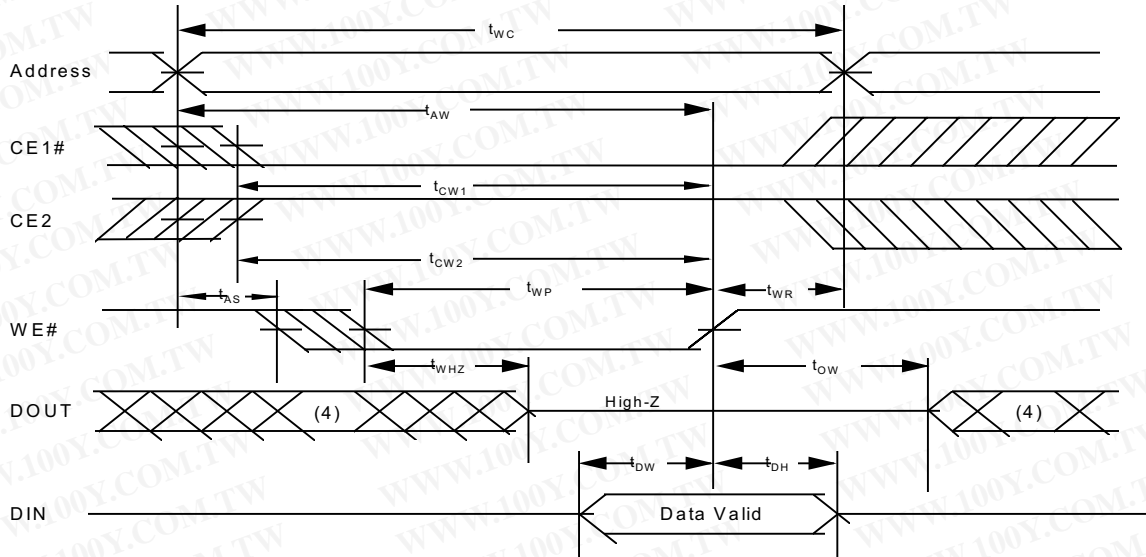

WRITE CYCLE 2 (CE1# and CE2 Controlled) (1,2,5)

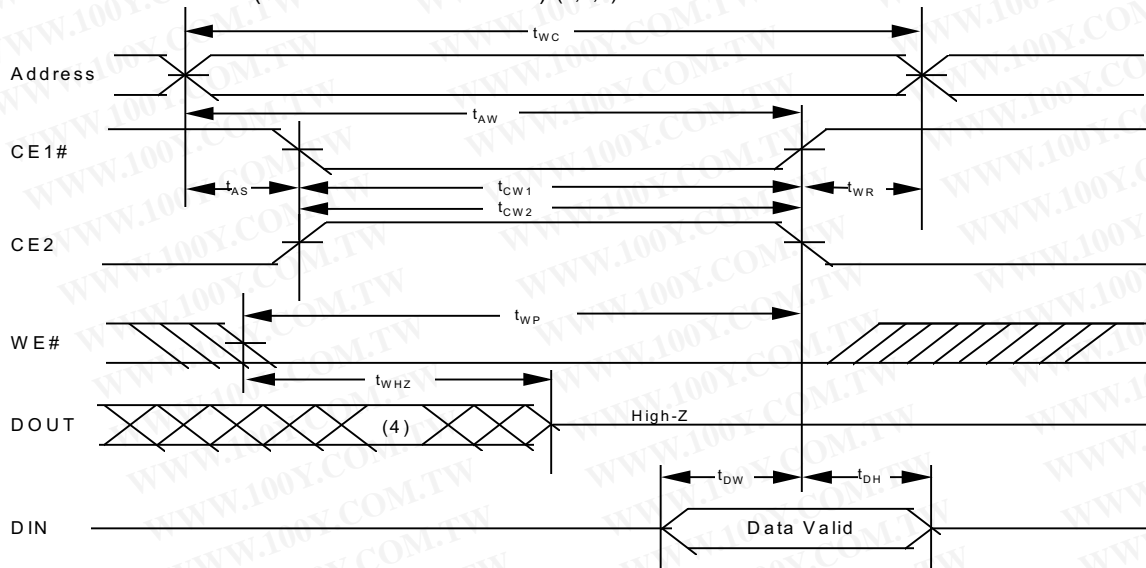

Notes :

1. WE# or CE# must be HIGH during all address transitions.
2. A write occurs during the overlap of a low CE# and a low WE#.
3. During a WE# controlled with write cycle with OE# LOW, t_{wp} must be greater than $t_{whz} + t_{dw}$ to allow the drivers to turn off and data to be placed on the bus.
4. During this period, I/O pins are in the output state, and input signals must not be applied.
5. If the CE# LOW transition occurs simultaneously with or after WE# LOW transition, the outputs remain in a high impedance state.
6. t_{ow} and t_{whz} are specified with $C_L = 5pF$. Transition is measured $\pm 500mV$ from steady state.

勝特力材料 886-3-5753170
 勝特力电子(上海) 86-21-34970699
 勝特力电子(深圳) 86-755-83298787
[Http://www.100y.com.tw](http://www.100y.com.tw)



DATA RETENTION CHARACTERISTICS (TA = 0°C to 70°C)

PARAMETER	SYMBOL	TEST CONDITION	MIN.	TYP.	MAX.	UNIT
Vcc for Data Retention	V _{DR}	CE1# ≥ V _{CC} -0.2V or CE2 ≤ 0.2V	3	-	5.5	V
Data Retention Current	I _{DR}	V _{CC} =3V CE1# ≥ V _{CC} -0.2V or CE2 ≤ 0.2V	-	-	3	mA
Chip Disable to Data Retention Time	t _{CDR}	See Data Retenti Waveforms (below)	0	-	-	ns
Recovery Time	t _R		3	-	-	ns

DATA RETENTION WAVEFORM

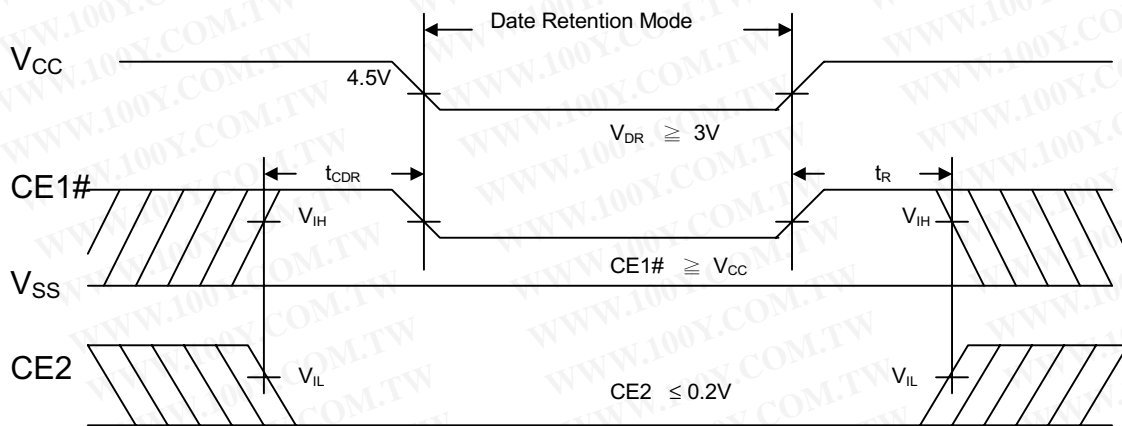

勝特力材料 886-3-5753170
 勝特力电子(上海) 86-21-34970699
 勝特力电子(深圳) 86-755-83298787
[Http://www.100y.com.tw](http://www.100y.com.tw)



UTRON

UT611024

Rev 1.3

128K X 8 BIT HIGH SPEED CMOS SRAM

PACKAGE OUTLINE DIMENSION

32 PIN P-DIP (300MIL) PACKAGE OUTLINE DIMENSION

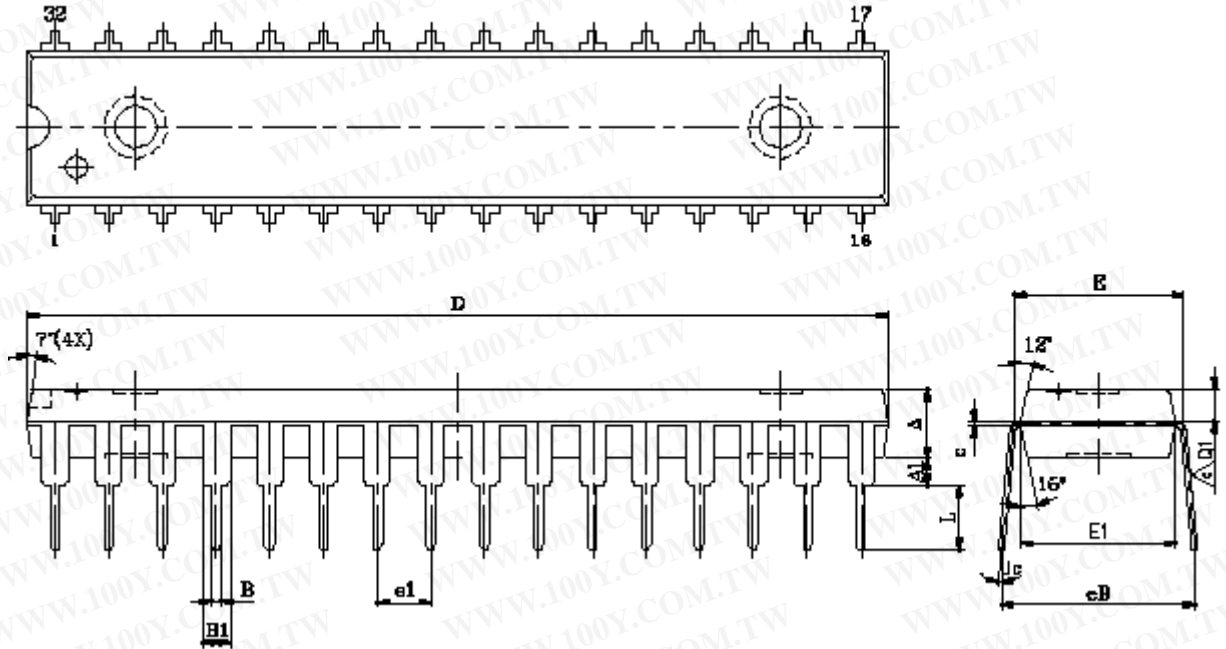

UNIT SYMBOL	INCH(BASE)	MM(REF)
A	0.130 ±0.005	3.302 ±0.127
A1	0.015(MIN)	0.381 (MIN)
B	0.018 ±0.004	0.457 ±0.102
B1	0.050 ±0.008	1.270 ±0.203
c	0.010 ±0.004	0.254 ±0.102
D	1.600 ±0.005	40.640 ±0.127
E	0.315 ±0.010	8.001 ±0.254
E1	0.288 ±0.004	7.315 ±0.102
e1	0.100 TYP	2.540 TYP
eB	0.350 ±0.020	8.890 ±0.508
L	0.125 (MIN)	3.175 (MIN)
Q1	0.060 ±0.005	1.524 ±0.127
1c	0°~10°	0°~10°



Note :

1. All EDGE WITH MATTE FINISH.
2. DIMENSION D AND E1 DO NOT INCLUDE MOLD FLASH OR PROTRUSION.

勝特力材料 886-3-5753170
 勝特力电子(上海) 86-21-34970699
 勝特力电子(深圳) 86-755-83298787
[Http://www.100y.com.tw](http://www.100y.com.tw)



UTRON

UT611024

Rev 1.3

128K X 8 BIT HIGH SPEED CMOS SRAM

32PIN SOJ PACKAGE OUTLINE DIMENSION

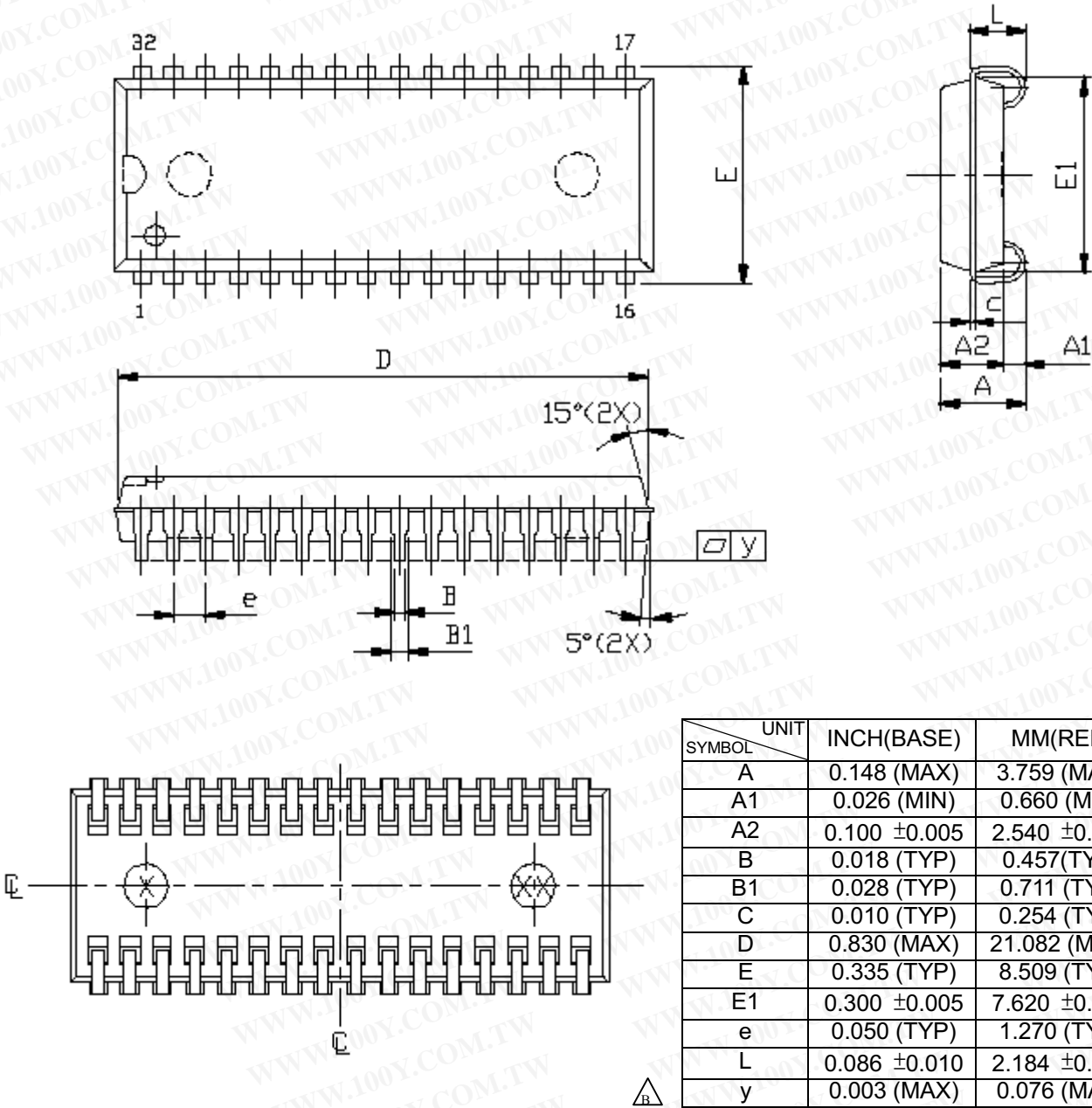

勝特力材料 886-3-5753170
 勝特力电子(上海) 86-21-34970699
 勝特力电子(深圳) 86-755-83298787
[Http://www.100y.com.tw](http://www.100y.com.tw)



UTRON

UT611024

Rev 1.3

128K X 8 BIT HIGH SPEED CMOS SRAM

32PIN TSOP-I PACKAGE OUTLINE DIMENSION

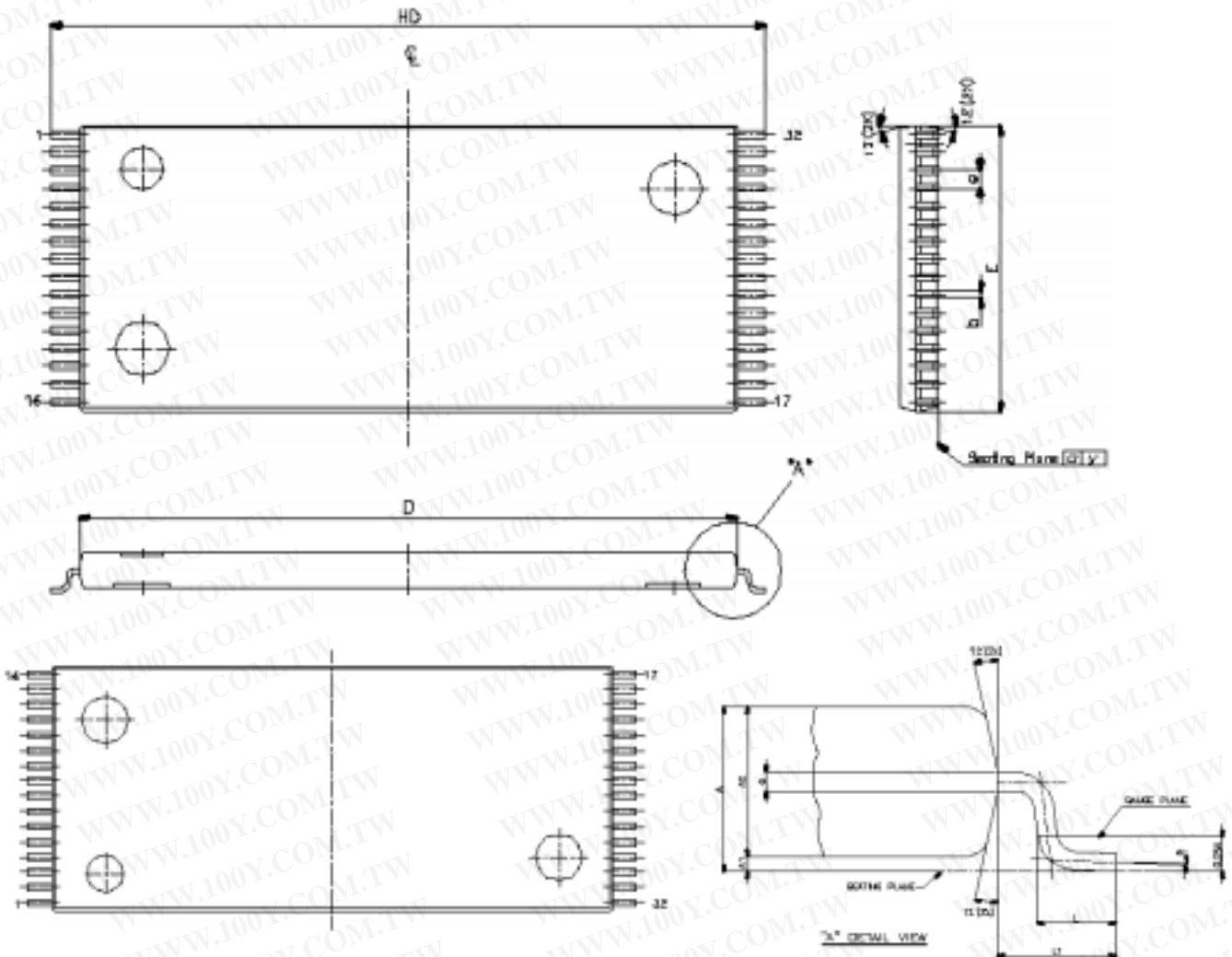

NOTE: 1. L/F MT'L: ALLOY

SYMBOL	UNIT	INCH(BASE)	MM(REF)
A		0.047 (MAX)	1.20 (MAX)
A1		0.004 ±0.002	0.10 ±0.05
A2		0.039 ±0.002	1.00 ±0.05
b		0.008 + 0.002 - 0.001	0.20 + 0.05 - 0.03
c		0.005 (TYP)	0.127 (TYP)
D		0.724 ±0.004	18.40 ±0.10
E		0.315 ±0.004	8.00 ±0.10
e		0.020 (TYP)	0.50 (TYP)
HD		0.787 ±0.008	20.00 ±0.20
L		0.0197 ±0.004	0.50 ±0.10
L1		0.0315 ±0.004	0.08 ±0.10
y		0.003 (MAX)	0.076 (MAX)
θ		0°~5°	0°~5°

勝特力材料 886-3-5753170
 勝特力电子(上海) 86-21-34970699
 勝特力电子(深圳) 86-755-83298787
[Http://www.100y.com.tw](http://www.100y.com.tw)



UTRON

UT611024

Rev 1.3

128K X 8 BIT HIGH SPEED CMOS SRAM

32PIN 8mm x 13.4mm STSOP PACKAGE OUTLINE DIMENSION

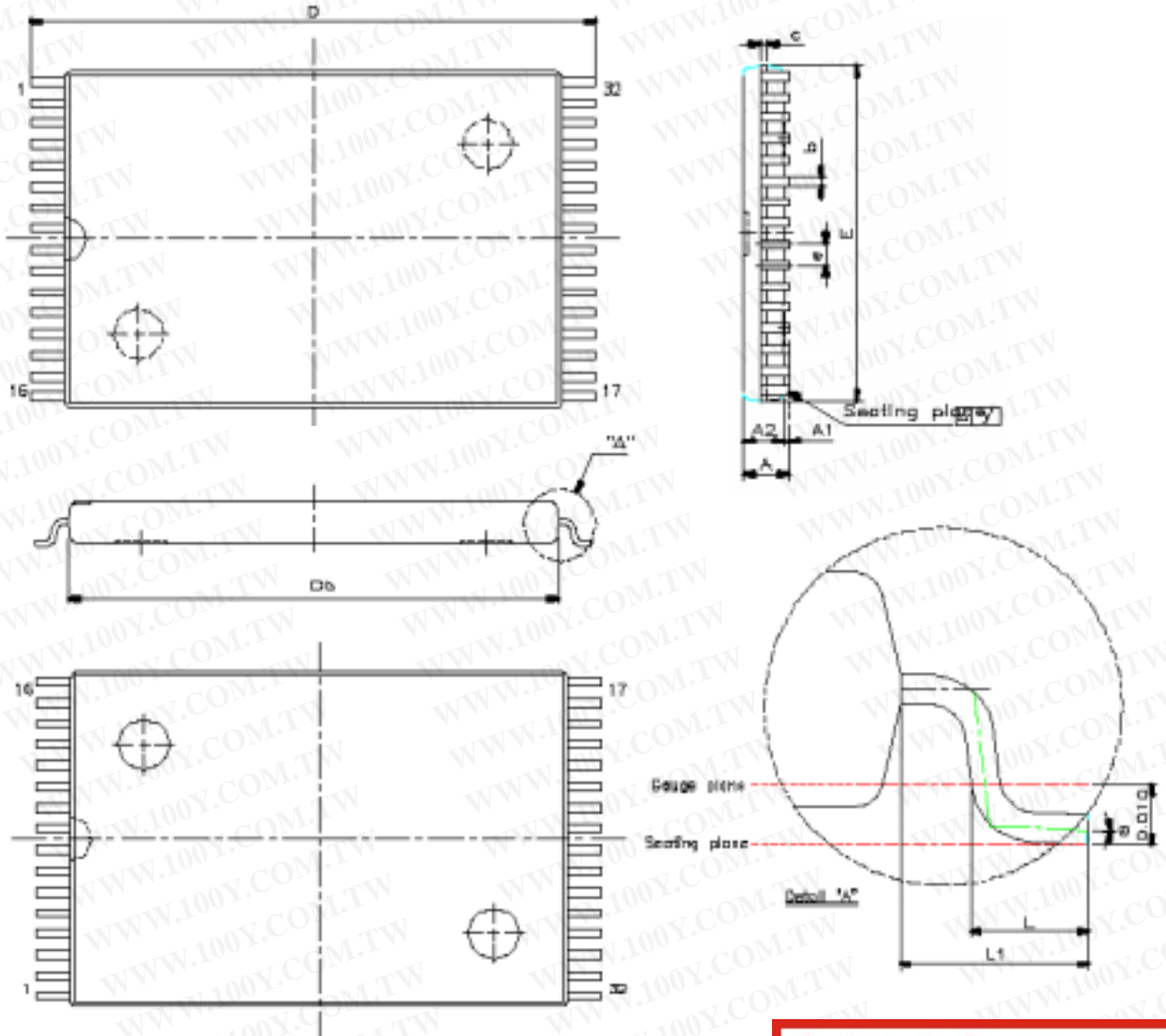

SYMBOL	UNIT	INCH(BASE)	MM(REF)
A		1.20(Max.)	0.047(Max.)
A1		0.10 ± 0.05	0.004 ± 0.002
A2		1.00 ± 0.05	0.039 ± 0.002
b		0.20(typ.)	0.006(typ.)
c		0.15(typ.)	0.006(typ.)
D		13.40 ± 0.20	0.526 ± 0.006
Db		11.80 ± 0.10	0.465 ± 0.004
E		8.000 ± 0.10	0.315 ± 0.004
e		0.50(typ.)	0.020(typ.)
L		0.50 ± 0.10	0.020 ± 0.004
L1		0.80 ± 0.10	0.0315 ± 0.004
y		0.08(Max.)	0.003(Max.)
e		0°~5°	0°~5°

勝特力材料 886-3-5753170
 勝特力电子(上海) 86-21-34970699
 勝特力电子(深圳) 86-755-83298787
[Http://www.100y.com.tw](http://www.100y.com.tw)

Note :

E dimension is not including End flash.

The total of both sides' end flash is not above 0.3mm.



UTRON

UT611024

Rev 1.3

128K X 8 BIT HIGH SPEED CMOS SRAM

ORDERING INFORMATION

PART NO.	ACCESS TIME (ns)	PACKAGE
UT611024KC-15	12	32PIN SKINNY PDIP
UT611024KC-15	15	32PIN SKINNY PDIP
UT611024JC-10	10	32PIN SOJ
UT611024JC-12	12	32PIN SOJ
UT611024JC-15	15	32PIN SOJ
UT611024LC-10	10	32PIN TSOP-1
UT611024LC-12	12	32PIN TSOP-1
UT611024LC-15	15	32PIN TSOP-1
UT611024LS-10	10	32PIN STSOP
UT611024LS-12	12	32PIN STSOP
UT611024LS-15	15	32PIN STSOP

勝特力材料 886-3-5753170
 勝特力电子(上海) 86-21-34970699
 勝特力电子(深圳) 86-755-83298787
[Http://www.100y.com.tw](http://www.100y.com.tw)