

勝特力材料 886-3-5773766  
勝特力电子(上海) 86-21-34970699  
勝特力电子(深圳) 86-755-83298787  
[Http://www.100y.com.tw](http://www.100y.com.tw)

# 8Gb B-die DDR4 SDRAM x16

96FBGA with Lead-Free & Halogen-Free  
(RoHS compliant)

1.2V

## datasheet

SAMSUNG ELECTRONICS RESERVES THE RIGHT TO CHANGE PRODUCTS, INFORMATION AND SPECIFICATIONS WITHOUT NOTICE.

Products and specifications discussed herein are for reference purposes only. All information discussed herein is provided on an "AS IS" basis, without warranties of any kind.

This document and all information discussed herein remain the sole and exclusive property of Samsung Electronics. No license of any patent, copyright, mask work, trademark or any other intellectual property right is granted by one party to the other party under this document, by implication, estoppel or otherwise.

Samsung products are not intended for use in life support, critical care, medical, safety equipment, or similar applications where product failure could result in loss of life or personal or physical harm, or any military or defense application, or any governmental procurement to which special terms or provisions may apply.

For updates or additional information about Samsung products, contact your nearest Samsung office.

All brand names, trademarks and registered trademarks belong to their respective owners.

(C) 2016 Samsung Electronics Co., Ltd. All rights reserved.

## Revision History

<u>Revision No.</u>	<u>History</u>	<u>Draft Date</u>	<u>Remark</u>	<u>Editor</u>
1.0	- First SPEC Release	Mar. 2015	-	J.Y.Lee
1.01	- Correction of typo	Apr. 2015	-	J.Y.Lee
1.02	- IDD current table Typo	11th Aug. 2015	-	J.Y.Lee
1.1	- Addition of values on page 10 [Table 5]	27th Oct. 2015	-	J.Y.Lee
1.2	- Addition of information about I-temp	3th Dec. 2015	-	J.Y.Lee
1.3	- Change of pinout typo	16th Dec. 2015	-	J.Y.Lee
1.4	- Addition of DDR4-2666	23th Mar. 2016	-	J.Y.Lee
1.5	- Correction of typo	27th May. 2016	-	J.Y.Lee
1.6	- Addition of DDR4-2666 (K4A8G165WB-BITD)	28th Jun. 2016	-	J.Y.Lee

## Table Of Contents

### **8Gb B-die DDR4 SDRAM x16**

1. Ordering Information .....	4
2. Key Features.....	4
3. Package pinout/Mechanical Dimension & Addressing.....	5
3.1 x16 Package Pinout (Top view) : 96ball FBGA Package .....	5
3.2 FBGA Package Dimension (x16).....	6
4. Input/Output Functional Description.....	7
5. DDR4 SDRAM Addressing .....	9
6. Absolute Maximum Ratings .....	10
6.1 Absolute Maximum DC Ratings.....	10
6.2 DRAM Component Operating Temperature Range .....	10
7. AC & DC Operating Conditions.....	10
8. AC & DC Input Measurement Levels .....	11
8.1 AC & DC Logic input levels for single-ended signals .....	11
8.2 VREF Tolerances .....	11
8.3 AC & DC Logic Input Levels for Differential Signals .....	12
8.3.1. Differential signals definition .....	12
8.3.2. Differential swing requirement for clock (CK <sub>t</sub> - CK <sub>c</sub> ).....	12
8.3.3. Single-ended requirements for differential signals .....	13
8.3.4. Address, Command and Control Overshoot and Undershoot specifications .....	14
8.3.5. Clock Overshoot and Undershoot Specifications .....	15
8.3.6. Data, Strobe and Mask Overshoot and Undershoot Specifications .....	16
8.4 Slew Rate Definitions .....	17
8.4.1. Slew Rate Definitions for Differential Input Signals (CK) .....	17
8.4.2. Slew Rate Definition for Single-ended Input Signals ( CMD/ADD ).....	18
8.5 Differential Input Cross Point Voltage.....	19
8.6 CMOS rail to rail Input Levels.....	20
8.6.1. CMOS rail to rail Input Levels for RESET <sub>n</sub> .....	20
8.7 AC and DC Logic Input Levels for DQS Signals.....	21
8.7.1. Differential signal definition .....	21
8.7.2. Differential swing requirements for DQS (DQS <sub>t</sub> - DQS <sub>c</sub> ).....	21
8.7.3. Peak voltage calculation method .....	21
8.7.4. Differential Input Cross Point Voltage .....	22
8.7.5. Differential Input Slew Rate Definition.....	23
9. AC and DC output Measurement levels.....	24
9.1 Output Driver DC Electrical Characteristics.....	24
9.1.1. Alert <sub>n</sub> output Drive Characteristic .....	26
9.1.2. Output Driver Characteristic of Connectivity Test ( CT ) Mode .....	26
9.2 Single-ended AC & DC Output Levels.....	27
9.3 Differential AC & DC Output Levels.....	27
9.4 Single-ended Output Slew Rate .....	28
9.5 Differential Output Slew Rate .....	29
9.6 Single-ended AC & DC Output Levels of Connectivity Test Mode .....	30
9.7 Test Load for Connectivity Test Mode Timing .....	30
10. Speed Bin .....	31
10.1 Speed Bin Table Note .....	36
11. IDD and IDDQ Specification Parameters and Test conditions.....	37
11.1 IDD, IPP and IDDQ Measurement Conditions.....	37
12. 8Gb DDR4 SDRAM B-die IDD Specification Table .....	52
13. Input/Output Capacitance .....	54
14. Electrical Characteristics & AC Timing .....	56
14.1 Reference Load for AC Timing and Output Slew Rate .....	56
14.2 tREFI .....	56
14.3 Timing Parameters by Speed Grade .....	57

14.4 The DQ input receiver compliance mask for voltage and timing ..... 63  
14.5 DDR4 Function Matrix ..... 67

## 1. Ordering Information

[ Table 1 ] Samsung 8Gb DDR4 B-die ordering information table

Organization	DDR4-2133 (15-15-15)	DDR4-2400 (17-17-17) <sup>2</sup>	DDR4-2666 (19-19-19) <sup>2</sup>	Package
512Mx16	K4A8G165WB-BCPB	K4A8G165WB-BCRC	K4A8G165WB-BCTD	96FBGA
512Mx16	K4A8G165WB-BIPB	K4A8G165WB-BIRC	K4A8G165WB-BITD	96FBGA

**NOTE :**

- Speed bin is in order of CL-tRCD-tRP.
- Backward compatible to lower frequency
- 13th digit stands for below.  
"C" : Commercial temp/Normal power  
"I" : Industrial temp/Normal power

## 2. Key Features

[ Table 2 ] 8Gb DDR4 B-die Speed bins

Speed	DDR4-1600	DDR4-1866	DDR4-2133	DDR4-2400	DDR4-2666	Unit
	11-11-11	13-13-13	15-15-15	17-17-17	19-19-19	
tCK(min)	1.25	1.071	0.938	0.833	0.75	ns
CAS Latency	11	13	15	17	19	nCK
tRCD(min)	13.75	13.92	14.06	14.16	14.25	ns
tRP(min)	13.75	13.92	14.06	14.16	14.25	ns
tRAS(min)	35	34	33	32	32	ns
tRC(min)	48.75	47.92	47.06	46.16	46.25	ns

- JEDEC standard 1.2V (1.14V~1.26V)
- $V_{DDQ} = 1.2V$  (1.14V~1.26V)
- $V_{PP} = 2.5V$  (2.375V~2.75V)
- 800 MHz  $f_{CK}$  for 1600Mb/sec/pin, 933 MHz  $f_{CK}$  for 1866Mb/sec/pin, 1067MHz  $f_{CK}$  for 2133Mb/sec/pin, 1200MHz  $f_{CK}$  for 2400Mb/sec/pin, 1333MHz  $f_{CK}$  for 2666Mb/sec/pin
- 8 Banks (2 Bank Groups)
- Programmable CAS Latency(posted CAS): 10,11,12,13,14,15,16,17,18,19,20
- Programmable CAS Write Latency (CWL) = 9,11 (DDR4-1600) , 10,12 (DDR4-1866) ,11,14 (DDR4-2133) ,12,16 (DDR4-2400) and 14,18 (DDR4-2666)
- 8-bit pre-fetch
- Burst Length: 8, 4 with tCCD = 4 which does not allow seamless read or write [either On the fly using A12 or MRS]
- Bi-directional Differential Data-Strobe
- Internal(self) calibration : Internal self calibration through ZQ pin (RZQ : 240 ohm  $\pm$  1%)
- On Die Termination using ODT pin
- Average Refresh Period 7.8us at lower than  $T_{CASE} 85^{\circ}C$ , 3.9us at  $85^{\circ}C < T_{CASE} \leq 95^{\circ}C$
- Support Industrial Temp ( -40 ~ 95°C )
  - tREFI 7.8us at  $-40^{\circ}C \leq T_{CASE} \leq 85^{\circ}C$
  - tREFI 3.9us at  $85^{\circ}C < T_{CASE} \leq 95^{\circ}C$
- Asynchronous Reset
- Package : 96 balls FBGA - x16
- All of Lead-Free products are compliant for RoHS
- All of products are Halogen-free
- CRC(Cyclic Redundancy Check) for Read/Write data security
- Command address parity check
- DBI(Data Bus Inversion)
- Gear down mode
- POD (Pseudo Open Drain) interface for data input/output
- Internal VREF for data inputs
- External VPP for DRAM Activating Power
- PPR and sPPR is supported

The 8Gb DDR4 SDRAM B-die is organized as a 64Mbit x 16 I/Os x 8banks device. This synchronous device achieves high speed double-data-rate transfer rates of up to 2666Mb/sec/pin (DDR4-2666) for general applications.

The chip is designed to comply with the following key DDR4 SDRAM features such as posted CAS, Programmable CWL, Internal (Self) Calibration, On Die Termination using ODT pin and Asynchronous Reset .

All of the control and address inputs are synchronized with a pair of externally supplied differential clocks. Inputs are latched at the crosspoint of differential clocks (CK rising and  $\overline{CK}$  falling). All I/Os are synchronized with a pair of bidirectional strobes (DQS and  $\overline{DQS}$ ) in a source synchronous fashion. The address bus is used to convey row, column, and bank address information in a  $\overline{RAS}/CAS$  multiplexing style. The DDR4 device operates with a single 1.2V (1.14V~1.26V) power supply, 1.2V(1.14V~1.26V)  $V_{DDQ}$  and 2.5V (2.375V~2.75V)  $V_{PP}$ .

The 8Gb DDR4 B-die device is available in 96ball FBGAs(x16).

- NOTE :**
- This data sheet is an abstract of full DDR4 specification and does not cover the common features which are described in "DDR4 SDRAM Device Operation & Timing Diagram".
  - The functionality described and the timing specifications included in this data sheet are for the DLL Enabled mode of operation.

### 3. Package pinout/Mechanical Dimension & Addressing

#### 3.1 x16 Package Pinout (Top view) : 96ball FBGA Package

	1	2	3	4	5	6	7	8	9	
A	VDDQ	VSSQ	DQU0				DQSU_c	VSSQ	VDDQ	A
B	VPP	VSS	VDD				DQSU_t	DQU1	VDD	B
C	VDDQ	DQU4	DQU2				DQU3	DQU5	VSSQ	C
D	VDD	VSSQ	DQU6				DQU7	VSSQ	VDDQ	D
E	VSS	DMU_n/ DBIU_n	VSSQ				DML_n DBIL_n	VSSQ	VSS	E
F	VSSQ	VDDQ	DQSL_c				DQL1	VDDQ	ZQ	F
G	VDDQ	DQL0	DQSL_t				VDD	VSS	VDDQ	G
H	VSSQ	DQL4	DQL2				DQL3	DQL5	VSSQ	H
J	VDD	VDDQ	DQL6				DQL7	VDDQ	VDD	J
K	VSS	CKE	ODT				CK_t	CK_c	VSS	K
L	VDD	WE_n/ A14	ACT_n				CS_n	RAS_n	VDD	L
M	VREFCA	BG0	A10/AP				A12/BC_n	CAS_n/ A15	VSS	M
N	VSS	BA0	A4				A3	BA1	TEN	N
P	RESET_n	A6	A0				A1	A5	ALERT_n	P
R	VDD	A8	A2				A9	A7	VPP	R
T	VSS	A11	PAR				NC	A13	VDD	T

#### Ball Locations (x16)

- Populated ball
- + Ball not populated

Top view  
(See the balls through the package)

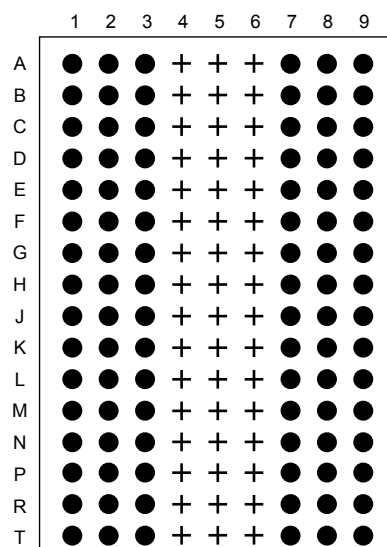

3.2 FBGA Package Dimension (x16)

Units : Millimeters

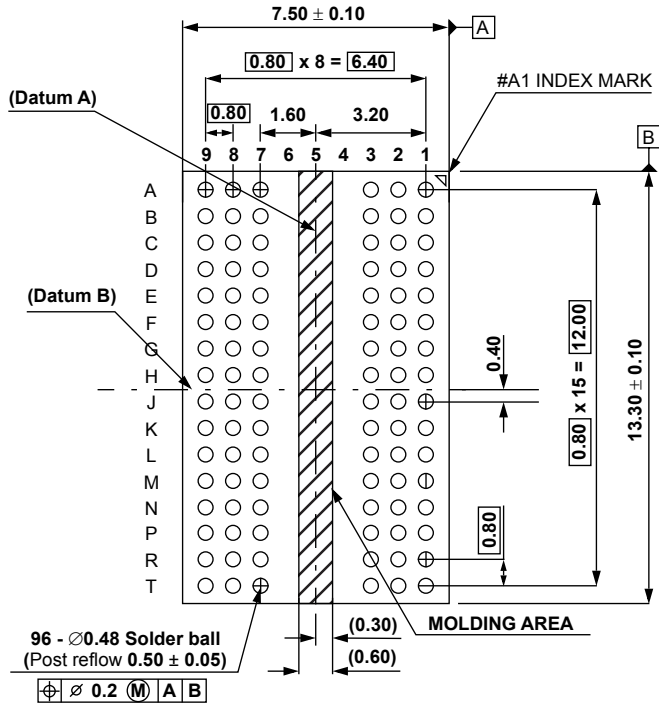

BOTTOM VIEW

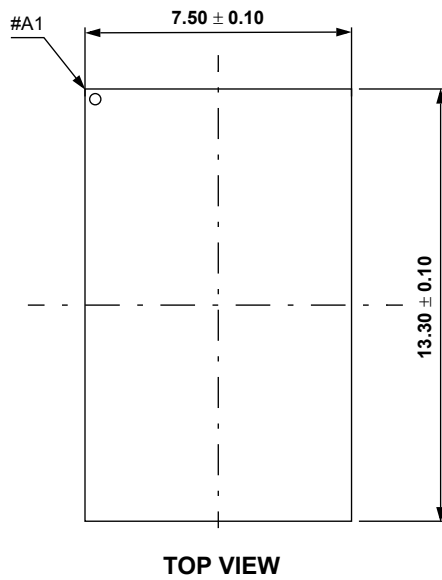

TOP VIEW

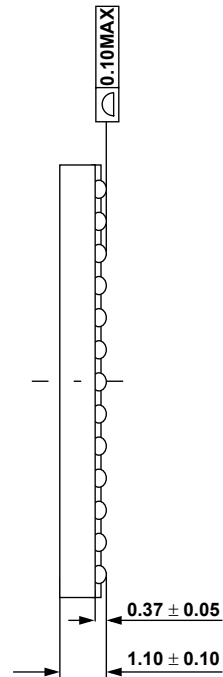

## 4. Input/Output Functional Description

[ Table 3 ] Input/Output function description

Symbol	Type	Function
CK_t, CK_c	Input	Clock: CK_t and CK_c are differential clock inputs. All address and control input signals are sampled on the crossing of the positive edge of CK_t and negative edge of CK_c.
CKE, (CKE1)	Input	Clock Enable: CKE HIGH activates, and CKE Low deactivates, internal clock signals and device input buffers and output drivers. Taking CKE Low provides Precharge Power-Down and Self-Refresh operation (all banks idle), or Active Power-Down (row Active in any bank). CKE is synchronous for Self-Refresh exit. After VREFCA and Internal DQ Vref have become stable during the power on and initialization sequence, they must be maintained during all operations (including Self-Refresh). CKE must be maintained high throughout read and write accesses. Input buffers, excluding CK_t,CK_c, ODT and CKE are disabled during power-down. Input buffers, excluding CKE, are disabled during Self-Refresh.
CS_n, (CS1_n)	Input	Chip Select: All commands are masked when CS_n is registered HIGH. CS_n provides for external Rank selection on systems with multiple Ranks. CS_n is considered part of the command code.
C0,C1,C2	Input	Chip ID : Chip ID is only used for 3DS for 2,4,8high stack via TSV to select each slice of stacked component. Chip ID is considered part of the command code
ODT, (ODT1)	Input	On Die Termination: ODT (registered HIGH) enables RTT_NOM termination resistance internal to the DDR4 SDRAM. When enabled, ODT is only applied to each DQ, DQS_t, DQS_c and DM_n/DBI_n/ TDQS_t, NU/TDQS_c (When TDQS is enabled via Mode Register A11=1 in MR1) signal for x8 conurations. For x16 conuration ODT is applied to each DQ, DQSU_t, DQSU_c, DQSL_t, DQSL_c, DMU_n, and DML_n signal. The ODT pin will be ignored if MR1 is programmed to disable RTT_NOM.
ACT_n	Input	Activation Command Input : ACT_n defines the Activation command being entered along with CS_n. The input into RAS_n/A16, CAS_n/A15 and WE_n/A14 will be considered as Row Address A16, A15 and A14
RAS_n/A16. CAS_n/A15. WE_n/A14	Input	Command Inputs: RAS_n/A16, CAS_n/A15 and WE_n/A14 (along with CS_n) define the command being entered. Those pins have multi function. For example, for activation with ACT_n Low, those are Addressing like A16,A15 and A14 but for non-activation command with ACT_n High, those are Command pins for Read, Write and other command defined in command truth table
DM_n/DBI_n/TDQS_t, (DMU_n/DBIU_n), (DML_n/DBIL_n)	Input/Output	Input Data Mask and Data Bus Inversion: DM_n is an input mask signal for write data. Input data is masked when DM_n is sampled LOW coincident with that input data during a Write access. DM_n is sampled on both edges of DQS. DM is muxed with DBI function by Mode Register A10,A11,A12 setting in MR5. For x8 device, the function of DM or TDQS is enabled by Mode Register A11 setting in MR1. DBI_n is an input/output identifying whether to store/output the true or inverted data. If DBI_n is LOW, the data will be stored/output after inversion inside the DDR4 SDRAM and not inverted if DBI_n is HIGH. TDQS is only supported in X8
BG0 - BG1	Input	Bank Group Inputs : BG0 - BG1 define to which bank group an Active, Read, Write or Precharge command is being applied. BG0 also determines which mode register is to be accessed during a MRS cycle. X4/8 have BG0 and BG1 but X16 has only BG0
BA0 - BA1	Input	Bank Address Inputs: BA0 - BA1 define to which bank an Active, Read, Write or Precharge command is being applied. Bank address also determines which mode register is to be accessed during a MRS cycle.
A0 - A17	Input	Address Inputs: Provide the row address for ACTIVATE Commands and the column address for Read/Write commands to select one location out of the memory array in the respective bank. (A10/AP, A12/BC_n, RAS_n/A16, CAS_n/A15 and WE_n/A14 have additional functions, see other rows.The address inputs also provide the op-code during Mode Register Set commands.A17 is only defined for the x4 conuration.
A10 / AP	Input	Auto-precharge: A10 is sampled during Read/Write commands to determine whether Autoprecharge should be performed to the accessed bank after the Read/Write operation. (HIGH: Autoprecharge; LOW: no Autoprecharge).A10 is sampled during a Precharge command to determine whether the Precharge applies to one bank (A10 LOW) or all banks (A10 HIGH). If only one bank is to be precharged, the bank is selected by bank addresses.
A12 / BC_n	Input	Burst Chop: A12 / BC_n is sampled during Read and Write commands to determine if burst chop (on-the-fly) will be performed. (HIGH, no burst chop; LOW: burst chopped). See command truth table for details.
RESET_n	Input	Active Low Asynchronous Reset: Reset is active when RESET_n is LOW, and inactive when RESET_n is HIGH. RESET_n must be HIGH during normal operation. RESET_n is a CMOS rail to rail signal with DC high and low at 80% and 20% of V <sub>DD</sub> ,
DQ	Input / Output	Data Input/ Output: Bi-directional data bus. If CRC is enabled via Mode register then CRC code is added at the end of Data Burst. Any DQ from DQ0~DQ3 may indicate the internal Vref level during test via Mode Register Setting MR4 A4=High. During this mode, RTT value should be set to Hi-Z. Refer to vendor specific datasheets to determine which DQ is used.
DQS_t, DQS_c, DQSU_t, DQSU_c, DQSL_t, DQSL_c	Input / Output	Data Strobe: output with read data, input with write data. Edge-aligned with read data, centered in write data. For the x16, DQSL corresponds to the data on DQL0-DQL7; DQSU corresponds to the data on DQU0-DQU7. The data strobe DQS_t, DQSL_t and DQSU_t are paired with differential signals DQS_c, DQSL_c, and DQSU_c, respectively, to provide differential pair signaling to the system during reads and writes. DDR4 SDRAM supports differential data strobe only and does not support single-ended.

Symbol	Type	Function
TDQS_t, TDQS_c	Output	Termination Data Strobe: TDQS_t/TDQS_c is applicable for x8 DRAMs only. When enabled via Mode Register A11 = 1 in MR1, the DRAM will enable the same termination resistance function on TDQS_t/TDQS_c that is applied to DQS_t/DQS_c. When disabled via mode register A11 = 0 in MR1, DM/DBI/TDQS will provide the data mask function or Data Bus Inversion depending on MR5; A11,12,10 and TDQS_c is not used. x4/x16 DRAMs must disable the TDQS function via mode register A11 = 0 in MR1.
PAR	Input	Command and Address Parity Input : DDR4 Supports Even Parity check in DRAM with MR setting. Once it's enabled via Register in MR5, then DRAM calculates Parity with ACT_n,RAS_n/A16,CAS_n/A15,WE_n/A14,BG0-BG1,BA0-BA1,A17-A0, and C0-C2 (3DS devices). Input parity should maintain at the rising edge of the clock and at the same time with command & address with CS_n LOW
ALERT_n	Input/Output	Alert : It has multi functions such as CRC error flag , Command and Address Parity error flag as Output signal. If there is error in CRC, then Alert_n goes LOW for the period time interval and goes back HIGH. If there is error in Command Address Parity Check, then Alert_n goes LOW for relatively long period until on going DRAM internal recovery transaction to complete. During Connectivity Test mode, this pin works as input. Using this signal or not is dependent on system. In case of not connected as Signal, ALERT_n Pin must be bounded to VDD on board.
TEN	Input	Connectivity Test Mode Enable : Required on X16 devices and optional input on x4/x8 with densities equal to or greater than 8Gb.HIGH in this pin will enable Connectivity Test Mode operation along with other pins. It is a CMOS rail to rail signal with AC high and low at 80% and 20% of VDD. Using this signal or not is dependent on System. This pin may be DRAM internally pulled low through a weak pull-down resistor to VSS.
NC		No Connect: No internal electrical connection is present.
VDDQ	Supply	DQ Power Supply: 1.2 V +/- 0.06 V
VSSQ	Supply	DQ Ground
VDD	Supply	Power Supply: 1.2 V +/- 0.06 V
VSS	Supply	Ground
VPP	Supply	DRAM Activating Power Supply: 2.5V ( 2.375V min , 2.75V max)
VREFCA	Supply	Reference voltage for CA
ZQ	Supply	Reference Pin for ZQ calibration
NOTE Input only pins (BG0-BG1,BA0-BA1, A0-A17, ACT_n, RAS_n/A16, CAS_n/A15, WE_n/A14, CS_n, CKE, ODT, and RESET_n) do not supply termination.		

## 5. DDR4 SDRAM Addressing

### 2 Gb Addressing Table

Configuration		512 Mb x4	256 Mb x8	128 Mb x16
Bank Address	# of Bank Groups	4	4	2
	BG Address	BG0~BG1	BG0~BG1	BG0
	Bank Address in a BG	BA0~BA1	BA0~BA1	BA0~BA1
Row Address		A0~A14	A0~A13	A0~A13
Column Address		A0~A9	A0~A9	A0~A9
Page size		512B	1KB	2KB

### 4 Gb Addressing Table

Configuration		1 Gb x4	512 Mb x8	256 Mb x16
Bank Address	# of Bank Groups	4	4	2
	BG Address	BG0~BG1	BG0~BG1	BG0
	Bank Address in a BG	BA0~BA1	BA0~BA1	BA0~BA1
Row Address		A0~A15	A0~A14	A0~A14
Column Address		A0~A9	A0~A9	A0~A9
Page size		512B	1KB	2KB

### 8 Gb Addressing Table

Configuration		2 Gb x4	1 Gb x8	512 Mb x16
Bank Address	# of Bank Groups	4	4	2
	BG Address	BG0~BG1	BG0~BG1	BG0
	Bank Address in a BG	BA0~BA1	BA0~BA1	BA0~BA1
Row Address		A0~A16	A0~A15	A0~A15
Column Address		A0~A9	A0~A9	A0~A9
Page size		512B	1KB	2KB

### 16 Gb Addressing Table

Configuration		4 Gb x4	2 Gb x8	1 Gb x16
Bank Address	# of Bank Groups	4	4	2
	BG Address	BG0~BG1	BG0~BG1	BG0
	Bank Address in a BG	BA0~BA1	BA0~BA1	BA0~BA1
Row Address		A0~A17	A0~A16	A0~A16
Column Address		A0~A9	A0~A9	A0~A9
Page size		512B	1KB	2KB

NOTE 1 : Page size is the number of bytes of data delivered from the array to the internal sense amplifiers when an ACTIVE command is registered.

Page size is per bank, calculated as follows:  $\text{page size} = 2^{\text{COLBITS}} \times \text{ORG} \div 8$   
 where, COLBITS = the number of column address bits, ORG = the number of I/O (DQ) bits

## 6. Absolute Maximum Ratings

### 6.1 Absolute Maximum DC Ratings

[ Table 4 ] Absolute Maximum DC Ratings

Symbol	Parameter	Rating	Units	NOTE
VDD	Voltage on VDD pin relative to Vss	-0.3 ~ 1.5	V	1,3
VDDQ	Voltage on VDDQ pin relative to Vss	-0.3 ~ 1.5	V	1,3
VPP	Voltage on VPP pin relative to Vss	-0.3 ~ 3.0	V	4
V <sub>IN</sub> , V <sub>OUT</sub>	Voltage on any pin except VREFCA relative to Vss	-0.3 ~ 1.5	V	1,3,5
T <sub>STG</sub>	Storage Temperature	-55 to +100	°C	1,2

**NOTE :**

- Stresses greater than those listed under “Absolute Maximum Ratings” may cause permanent damage to the device. This is a stress rating only and functional operation of the device at these or any other conditions above those indicated in the operational sections of this specification is not implied. Exposure to absolute maximum rating conditions for extended periods may affect reliability.
- Storage Temperature is the case surface temperature on the center/top side of the DRAM. For the measurement conditions, please refer to JESD51-2 standard.
- VDD and VDDQ must be within 300 mV of each other at all times; and VREFCA must be not greater than 0.6 x VDDQ, When VDD and VDDQ are less than 500 mV; VREFCA may be equal to or less than 300 mV
- VPP must be equal or greater than VDD/VDDQ at all times.
- Overshoot area above 1.5 V is specified in section 8.3.4, 8.3.5 and section 8.3.6..

### 6.2 DRAM Component Operating Temperature Range

[ Table 5 ] Temperature Range

Symbol	Parameter		rating	Unit	NOTE
T <sub>OPER</sub>	Operating Temperature Range	Normal	0 to 95	°C	1, 2, 4
		Industrial	-40 to 95	°C	1, 3, 4

**NOTE :**

- Operating Temperature T<sub>OPER</sub> is the case surface temperature on the center/top side of the DRAM.
- The Normal Temperature Range specifies the temperatures where all DRAM specifications will be supported. During operation, the DRAM case temperature must be maintained between 0-85°C under all operating conditions
- The Industrial Temperature Range specifies the temperatures where all DRAM specifications will be supported. During operation, the DRAM case temperature must be maintained between -40-95°C under all operating conditions
- Some applications require operation of the Extended Temperature Range between 85°C and 95°C case temperature. Full specifications are guaranteed in this range, but the following additional conditions apply:
  - Refresh commands must be doubled in frequency, therefore reducing the refresh interval tREFI to 3.9us.
  - If Self-Refresh operation is required in the Extended Temperature Range, then it is mandatory to use the Manual Self-Refresh mode with Extended Temperature Range capability (MR2 A6 = 0<sub>b</sub> and MR2 A7 = 1<sub>b</sub>).

## 7. AC & DC Operating Conditions

[ Table 6 ] Recommended DC Operating Conditions

Symbol	Parameter	Rating			Unit	NOTE
		Min.	Typ.	Max.		
VDD	Supply Voltage	1.14	1.2	1.26	V	1,2,3
VDDQ	Supply Voltage for Output	1.14	1.2	1.26	V	1,2,3
VPP	Peak-to-Peak Voltage	2.375	2.5	2.75	V	3

**NOTE :**

- Under all conditions VDDQ must be less than or equal to VDD.
- VDDQ tracks with VDD. AC parameters are measured with VDD and VDDQ tied together.
- DC bandwidth is limited to 20MHz.

## 8. AC & DC Input Measurement Levels

### 8.1 AC & DC Logic input levels for single-ended signals

[ Table 7 ] Single-ended AC & DC input levels for Command and Address

Symbol	Parameter	DDR4-1600/1866/2133/2400		DDR4-2666		Unit	NOT E
		Min.	Max.	Min.	Max.		
$V_{IH.CA}(DC75)$	DC input logic high	$V_{REFCA} + 0.075$	$V_{DD}$	TBD	TBD	V	
$V_{IL.CA}(DC75)$	DC input logic low	$V_{SS}$	$V_{REFCA} - 0.075$	TBD	TBD	V	
$V_{IH.CA}(AC100)$	AC input logic high	$V_{REF} + 0.1$	Note 2	TBD	TBD	V	1
$V_{IL.CA}(AC100)$	AC input logic low	Note 2	$V_{REF} - 0.1$	TBD	TBD	V	1
$V_{REFCA}(DC)$	Reference Voltage for ADD, CMD inputs	$0.49 * V_{DD}$	$0.51 * V_{DD}$	TBD	TBD	V	2,3

**NOTE :**

1. See "Overshoot and Undershoot Specifications".
2. The AC peak noise on  $V_{REFCA}$  may not allow  $V_{REFCA}$  to deviate from  $V_{REFCA}(DC)$  by more than  $\pm 1\% V_{DD}$  (for reference : approx.  $\pm 12mV$ )
3. For reference : approx.  $V_{DD}/2 \pm 12mV$

### 8.2 $V_{REF}$ Tolerances

The dc-tolerance limits and ac-noise limits for the reference voltages  $V_{REFCA}$  is illustrated in Figure 1. It shows a valid reference voltage  $V_{REF}(t)$  as a function of time. ( $V_{REF}$  stands for  $V_{REFCA}$  and  $V_{REFDQ}$  likewise).

$V_{REF}(DC)$  is the linear average of  $V_{REF}(t)$  over a very long period of time (e.g. 1 sec). This average has to meet the min/max requirement in Table 7 on page 11. Furthermore  $V_{REF}(t)$  may temporarily deviate from  $V_{REF}(DC)$  by no more than  $\pm 1\% V_{DD}$ .

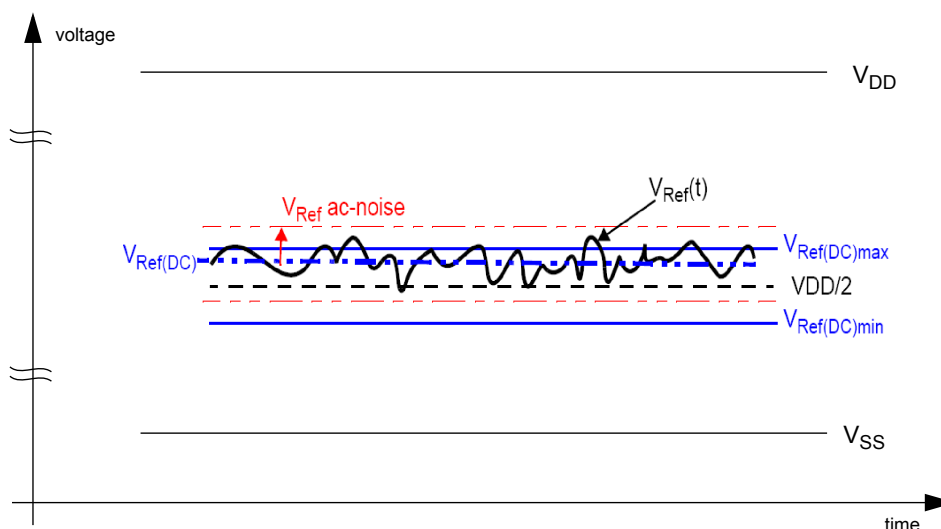

Figure 1. Illustration of  $V_{REF}(DC)$  tolerance and  $V_{REF}$  ac-noise limits

The voltage levels for setup and hold time measurements  $V_{IH}(AC)$ ,  $V_{IH}(DC)$ ,  $V_{IL}(AC)$  and  $V_{IL}(DC)$  are dependent on  $V_{REF}$ .

" $V_{REF}$ " shall be understood as  $V_{REF}(DC)$ , as defined in Figure 1.

This clarifies, that dc-variations of  $V_{REF}$  affect the absolute voltage a signal has to reach to achieve a valid high or low level and therefore the time to which setup and hold is measured. System timing and voltage budgets need to account for  $V_{REF}(DC)$  deviations from the optimum position within the data-eye of the input signals.

This also clarifies that the DRAM setup/hold specification and derating values need to include time and voltage associated with  $V_{REF}$  ac-noise. Timing and voltage effects due to ac-noise on  $V_{REF}$  up to the specified limit ( $\pm 1\%$  of  $V_{DD}$ ) are included in DRAM timings and their associated deratings.

### 8.3 AC & DC Logic Input Levels for Differential Signals

#### 8.3.1 Differential signals definition

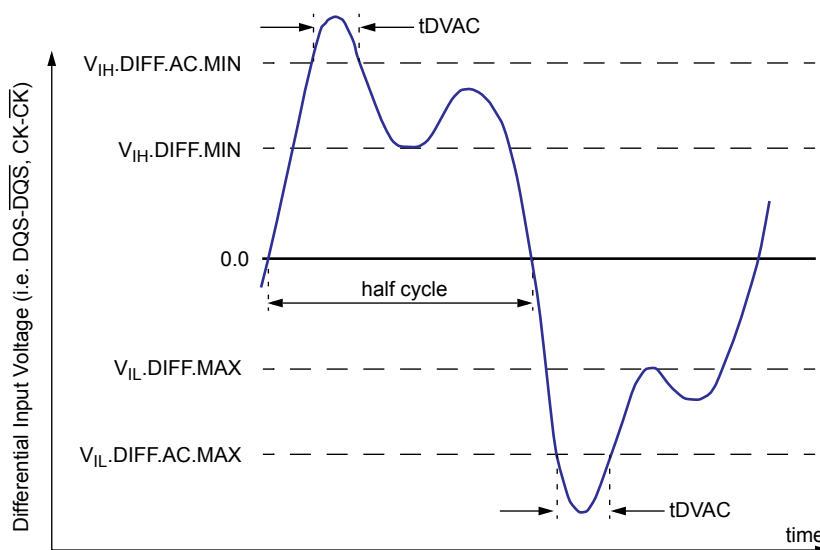

Figure 2. Definition of differential ac-swing and "time above ac level" tDVAC

**NOTE :**

1. Differential signal rising edge from V<sub>IL.DIFF.MAX</sub> to V<sub>IH.DIFF.MIN</sub> must be monotonic slope.
2. Differential signal falling edge from V<sub>IH.DIFF.MIN</sub> to V<sub>IL.DIFF.MAX</sub> must be monotonic slope.

#### 8.3.2 Differential swing requirement for clock (CK<sub>t</sub> - CK<sub>c</sub>)

[ Table 8 ] Differential AC & DC Input Levels

Symbol	Parameter	DDR4 -1600/1866/2133		DDR4 -2400/2666		unit	NOTE
		min	max	min	max		
V <sub>IHdiff</sub>	differential input high	+0.150	NOTE 3	TBD	NOTE 3	V	1
V <sub>ILdiff</sub>	differential input low	NOTE 3	-0.150	NOTE 3	TBD	V	1
V <sub>IHdiff(AC)</sub>	differential input high ac	2 x (V <sub>IH(AC)</sub> - V <sub>REF</sub> )	NOTE 3	2 x (V <sub>IH(AC)</sub> - V <sub>REF</sub> )	NOTE 3	V	2
V <sub>ILdiff(AC)</sub>	differential input low ac	NOTE 3	2 x (V <sub>IL(AC)</sub> - V <sub>REF</sub> )	NOTE 3	2 x (V <sub>IL(AC)</sub> - V <sub>REF</sub> )	V	2

**NOTE:**

1. Used to define a differential signal slew-rate.
2. for CK<sub>t</sub> - CK<sub>c</sub> use V<sub>IHCA</sub>/V<sub>ILCA(AC)</sub> of ADD/CMD and V<sub>REFCA</sub>;
3. These values are not defined; however, the differential signals CK<sub>t</sub> - CK<sub>c</sub>, need to be within the respective limits (V<sub>IHCA(AC)</sub> max, V<sub>ILCA(AC)</sub> min) for single-ended signals as well as the limitations for overshoot and undershoot.

[ Table 9 ] Allowed time before ringback (tDVAC) for CK\_t - CK\_c

Slew Rate [V/ns]	tDVAC [ps] @ $ V_{IH/Ldiff}(AC)  = 200mV$	
	min	max
> 4.0	120	-
4.0	115	-
3.0	110	-
2.0	105	-
1.8	100	-
1.6	95	-
1.4	90	-
1.2	85	-
1.0	80	-
< 1.0	80	-

### 8.3.3 Single-ended requirements for differential signals

Each individual component of a differential signal (CK\_t, CK\_c) has also to comply with certain requirements for single-ended signals. CK\_t and CK\_c have to approximately reach  $V_{SEHmin} / V_{SEmax}$  [approximately equal to the ac-levels  $\{V_{IH,CA}(AC) / V_{IL,CA}(AC)\}$  for ADD/CMD signals] in every half-cycle. Note that the applicable ac-levels for ADD/CMD might be different per speed-bin etc. E.g. if Different value than  $V_{IH,CA}(AC100)/V_{IL,CA}(AC100)$  is used for ADD/CMD signals, then these ac-levels apply also for the single-ended signals CK\_t and CK\_c .

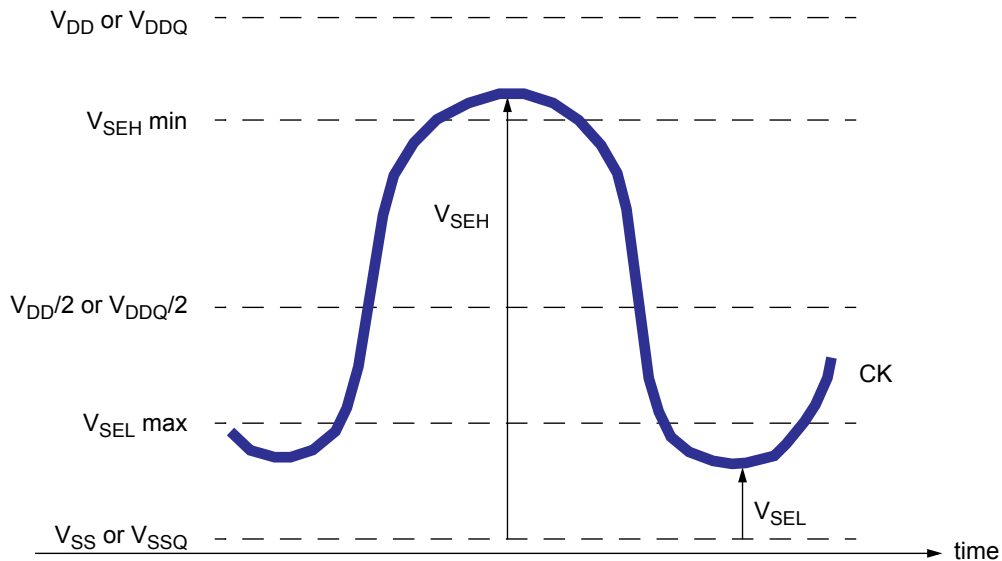

Figure 3. Single-ended requirement for differential signals

Note that while ADD/CMD signal requirements are with respect to  $V_{REFA}$ , the single-ended components of differential signals have a requirement with respect to  $V_{DD}/2$ ; this is nominally the same. The transition of single-ended signals through the ac-levels is used to measure setup time. For single-ended components of differential signals the requirement to reach  $V_{SEmax}$ ,  $V_{SEHmin}$  has no bearing on timing, but adds a restriction on the common mode characteristics of these signals.

[ Table 10 ] Single-ended levels for CK\_t, CK\_c

Symbol	Parameter	DDR4-1600/1866/2133		DDR4 -2400/2666		Unit	NOTE
		Min	Max	Min	Max		
V <sub>SEH</sub>	Single-ended high-level for CK_t, CK_c	(VDD/2)+0.100	NOTE3	TBD	NOTE3	V	1, 2
V <sub>SEL</sub>	Single-ended low-level for CK_t, CK_c	NOTE3	(VDD/2)-0.100	NOTE3	TBD	V	1, 2

NOTE :

1. For CK\_t - CK\_c use V<sub>IH,CA</sub>/V<sub>IL,CA</sub>(AC) of ADD/CMD;
2. V<sub>IH</sub>(AC)/V<sub>IL</sub>(AC) for ADD/CMD is based on V<sub>REFCA</sub>;
3. These values are not defined, however the single-ended signals CK\_t - CK\_c need to be within the respective limits (V<sub>IH,CA</sub>(DC) max, V<sub>IL,CA</sub>(DC)min) for single-ended signals as well as the limitations for overshoot and undershoot.

### 8.3.4 Address, Command and Control Overshoot and Undershoot specifications

[ Table 11 ] AC overshoot/undershoot specification for Address, Command and Control pins

Parameter	Specification					Unit
	DDR4-1600	DDR4-1866	DDR4-2133	DDR4-2400	DDR4-2666	
Maximum peak amplitude above VDD Absolute Max allowed for overshoot area	0.06	0.06	0.06	0.06	TBD	V
Delta value between VDD Absolute Max and VDD Max allowed for overshoot area	0.24	0.24	0.24	0.24	TBD	V
Maximum peak amplitude allowed for undershoot area	0.3	0.3	0.3	0.3	TBD	V-ns
Maximum overshoot area per 1tCK Above Absolute Max	0.0083	0.0071	0.0062	0.0055	TBD	V-ns
Maximum overshoot area per 1tCK Between Absolute Max and VDD Max	0.2550	0.2185	0.1914	0.1699	TBD	V-ns
Maximum undershoot area per 1tCK Below VSS	0.2644	0.2265	0.1984	0.1762	TBD	V-ns

(A0-A13,BG0-BG1,BA0-BA1,ACT\_n,RAS\_n,CAS\_n/A15,WE\_n/A14,CS\_n,CKE,ODT,C2-C0)

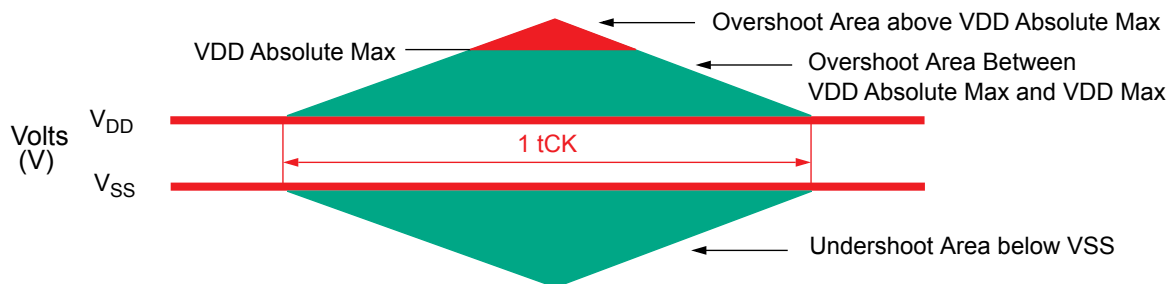

Figure 4. Address, Command and Control Overshoot and Undershoot Definition

### 8.3.5 Clock Overshoot and Undershoot Specifications

[ Table 12 ] AC overshoot/undershoot specification for Clock

Parameter	Specification					Unit
	DDR4-1600	DDR4-1866	DDR4-2133	DDR4-2400	DDR4-2666	
Maximum peak amplitude above VDD Absolute Max allowed for overshoot area	0.06	0.06	0.06	0.06	TBD	V
Delta value between VDD Absolute Max and VDD Max allowed for overshoot area	0.24	0.24	0.24	0.24	TBD	V
Maximum peak amplitude allowed for undershoot area	0.3	0.3	0.3	0.3	TBD	V
Maximum overshoot area per 1UI Above Absolute Max	0.0038	0.0032	0.0028	0.0025	TBD	V-ns
Maximum overshoot area per 1UI Between Absolute Max and VDD Max	0.1125	0.0964	0.0844	0.0750	TBD	V-ns
Maximum undershoot area per 1UI Below VSS	0.1144	0.0980	0.0858	0.0762	TBD	V-ns

(CK<sub>t</sub>, CK<sub>c</sub>)

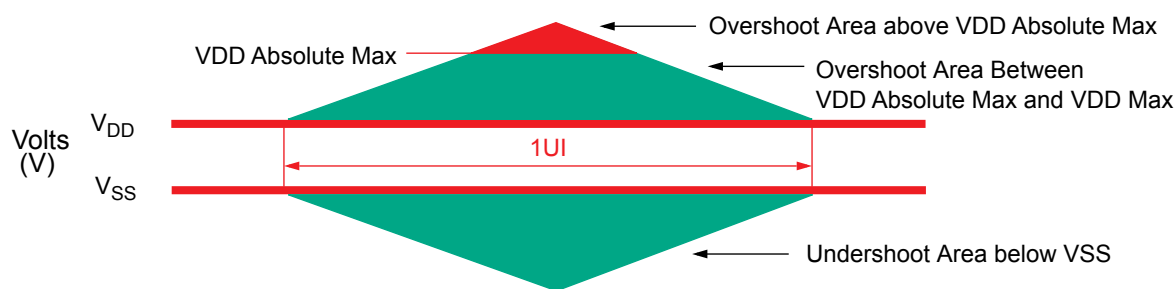

Figure 5. Clock Overshoot and Undershoot Definition

### 8.3.6 Data, Strobe and Mask Overshoot and Undershoot Specifications

[ Table 13 ] AC overshoot/undershoot specification for Data, Strobe and Mask

Parameter	Specification					Unit
	DDR4-1600	DDR4-1866	DDR4-2133	DDR4-2400	DDR4-2666	
Maximum peak amplitude above Max absolute level of Vin, Vout	0.16	0.16	0.16	0.16	TBD	V
Overshoot area Between Max Absolute level of Vin, Vout and VDDQ Max	0.24	0.24	0.24	0.24	TBD	V
Undershoot area Between Min absolute level of Vin, Vout and VSSQ	0.30	0.30	0.30	0.30	TBD	V
Maximum peak amplitude below Min absolute level of Vin, Vout	0.10	0.10	0.10	0.10	TBD	V
Maximum overshoot area per 1UI Above Max absolute level of Vin, Vout	0.0150	0.0129	0.0113	0.0100	TBD	V-ns
Maximum overshoot area per 1UI Between Max absolute level of Vin,Vout and VDDQ Max	0.1050	0.0900	0.0788	0.0700	TBD	V-ns
Maximum undershoot area per 1UI Between Min absolute level of Vin,Vout and VSSQ	0.1050	0.0900	0.0788	0.0700	TBD	V-ns
Maximum undershoot area per 1UI Below Min absolute level of Vin,Vout	0.0150	0.0129	0.0113	0.0100	TBD	V-ns

(DQ, DQS\_t, DQS\_c, DM\_n, DBI\_n, TDQS\_t, TDQS\_c)

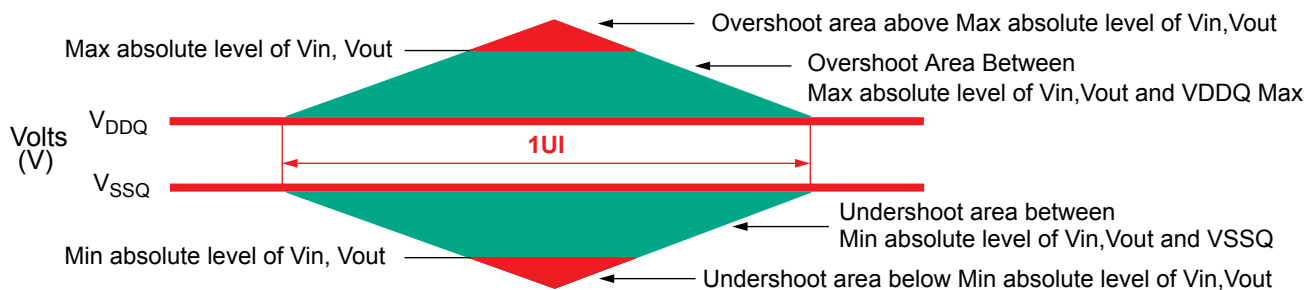

Figure 6. Data, Strobe and Mask Overshoot and Undershoot Definition

## 8.4 Slew Rate Definitions

### 8.4.1 Slew Rate Definitions for Differential Input Signals (CK)

Input slew rate for differential signals (CK<sub>t</sub>, CK<sub>c</sub>) are defined and measured as shown in Table 14 and Figure 7.

[ Table 14 ] Differential input slew rate definition

Description	Measured		Defined by
	From	To	
Differential input slew rate for rising edge(CK <sub>t</sub> - CK <sub>c</sub> )	V <sub>ILdiffmax</sub>	V <sub>IHdiffmin</sub>	$[ V_{IHdiffmin} - V_{ILdiffmax} ] / \Delta TR_{diff}$
Differential input slew rate for falling edge(CK <sub>t</sub> - CK <sub>c</sub> )	V <sub>IHdiffmin</sub>	V <sub>ILdiffmax</sub>	$[ V_{IHdiffmin} - V_{ILdiffmax} ] / \Delta TF_{diff}$

**NOTE :**

The differential signal (i.e. CK -  $\overline{CK}$  and DQS -  $\overline{DQS}$ ) must be linear between these thresholds.

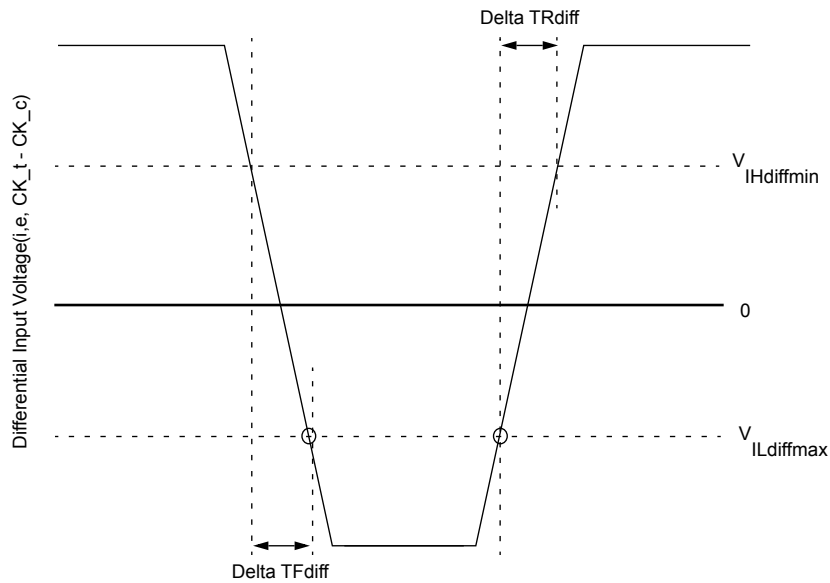
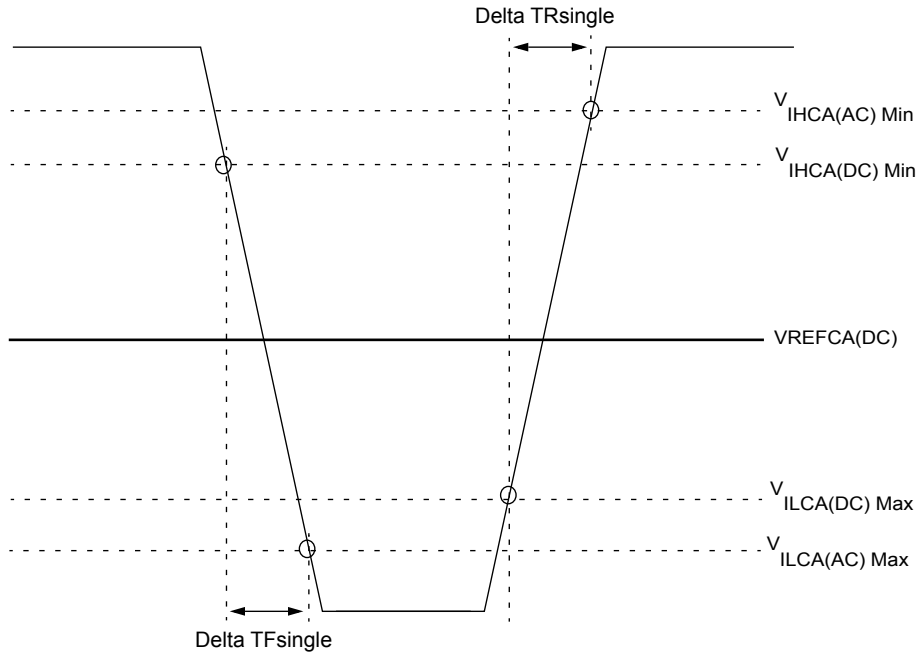

Figure 7. Differential Input Slew Rate definition for CK,  $\overline{CK}$

8.4.2 Slew Rate Definition for Single-ended Input Signals ( CMD/ADD )



- NOTE :**
1. Single-ended input slew rate for rising edge =  $\{ V_{IHCA(AC)Min} - V_{ILCA(DC)Max} \} / \Delta T_{Rsingle}$
  2. Single-ended input slew rate for falling edge =  $\{ V_{IHCA(DC)Min} - V_{ILCA(AC)Max} \} / \Delta T_{Fsingle}$
  3. Single-ended signal rising edge from  $V_{ILCA(DC)Max}$  to  $V_{IHCA(DC)Min}$  must be monotonic slope.
  4. Single-ended signal falling edge from  $V_{IHCA(DC)Min}$  to  $V_{ILCA(DC)Max}$  must be monotonic slope.

Figure 8. Single-ended Input Slew Rate definition for CMD and ADD

### 8.5 Differential Input Cross Point Voltage

To guarantee tight setup and hold times as well as output skew parameters with respect to clock, each cross point voltage of differential input signals (CK<sub>t</sub>, CK<sub>c</sub>) must meet the requirements in Table. The differential input cross point voltage VIX is measured from the actual cross point of true and complement signals to the midlevel between of VDD and VSS.

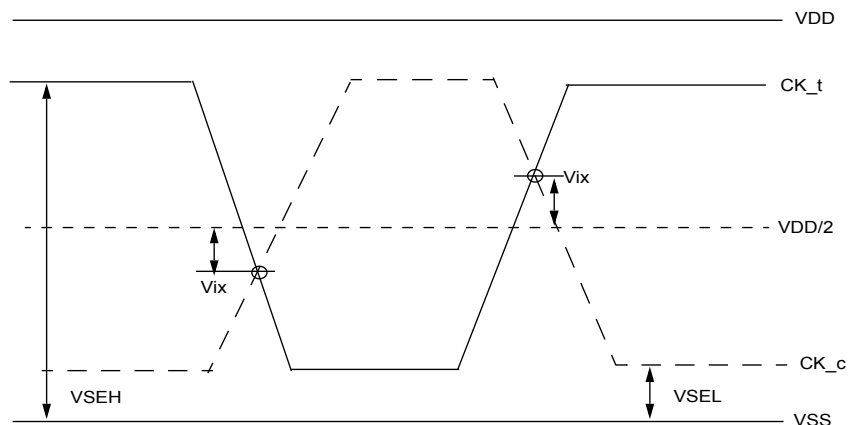

Figure 9. Vix Definition (CK)

[ Table 15 ] Cross point voltage for differential input signals (CK)

Symbol	Parameter	DDR4-1600/1866/2133			
		min		max	
-	Area of VSEH, VSEL	$VSEL \leq VDD/2 - 145mV$	$VDD/2 - 145mV \leq VSEL \leq VDD/2 - 100mV$	$VDD/2 + 100mV \leq VSEL \leq VDD/2 + 145mV$	$VDD/2 + 145mV \leq VSEL$
VIX(CK)	Differential Input Cross Point Voltage relative to VDD/2 for CK <sub>t</sub> , CK <sub>c</sub>	-120mV	$-(VDD/2 - VSEL) + 25mV$	$(VSEH - VDD/2) - 25mV$	120mV

Symbol	Parameter	DDR4-2400/2666			
		min		max	
-	Area of VSEH, VSEL	TBD	TBD	TBD	TBD
VIX(CK)	Differential Input Cross Point Voltage relative to VDD/2 for CK <sub>t</sub> , CK <sub>c</sub>	TBD	TBD	TBD	TBD

## 8.6 CMOS rail to rail Input Levels

### 8.6.1 CMOS rail to rail Input Levels for RESET\_n

[ Table 16 ] CMOS rail to rail Input Levels for RESET\_n

Parameter	Symbol	Min	Max	Unit	NOTE
AC Input High Voltage	VIH(AC)_RESET	0.8*VDD	VDD	V	6
DC Input High Voltage	VIH(DC)_RESET	0.7*VDD	VDD	V	2
DC Input Low Voltage	VIL(DC)_RESET	VSS	0.3*VDD	V	1
AC Input Low Voltage	VIL(AC)_RESET	VSS	0.2*VDD	V	7
Rising time	TR_RESET	-	1.0	us	4
RESET pulse width	tPW_RESET	1.0	-	us	3,5

- NOTE :**
1. After RESET\_n is registered LOW, RESET\_n level shall be maintained below VIL(DC)\_RESET during tPW\_RESET, otherwise, SDRAM may not be reset.
  2. Once RESET\_n is registered HIGH, RESET\_n level must be maintained above VIH(DC)\_RESET, otherwise, SDRAM operation will not be guaranteed until it is reset asserting RESET\_n signal LOW.
  3. RESET is destructive to data contents.
  4. No slope reversal(ringback) requirement during its level transition from Low to High.
  5. This definition is applied only "Reset Procedure at Power Stable".
  6. Overshoot might occur. It should be limited by the Absolute Maximum DC Ratings.
  7. Undershoot might occur. It should be limited by Absolute Maximum DC Ratings

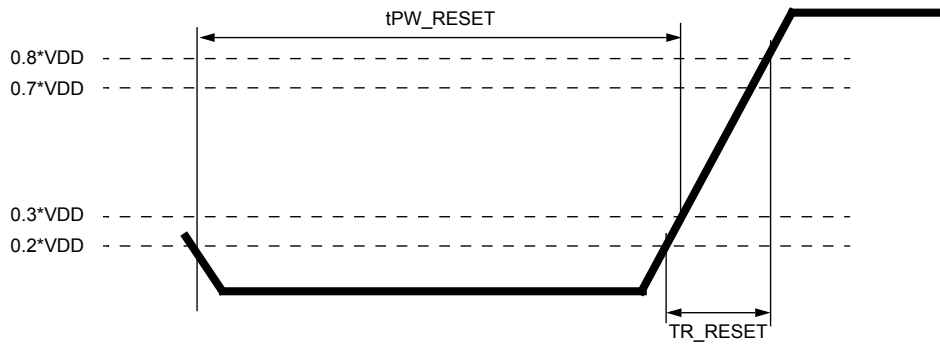

Figure 10. RESET\_n Input Slew Rate Definition

## 8.7 AC and DC Logic Input Levels for DQS Signals

### 8.7.1 Differential signal definition

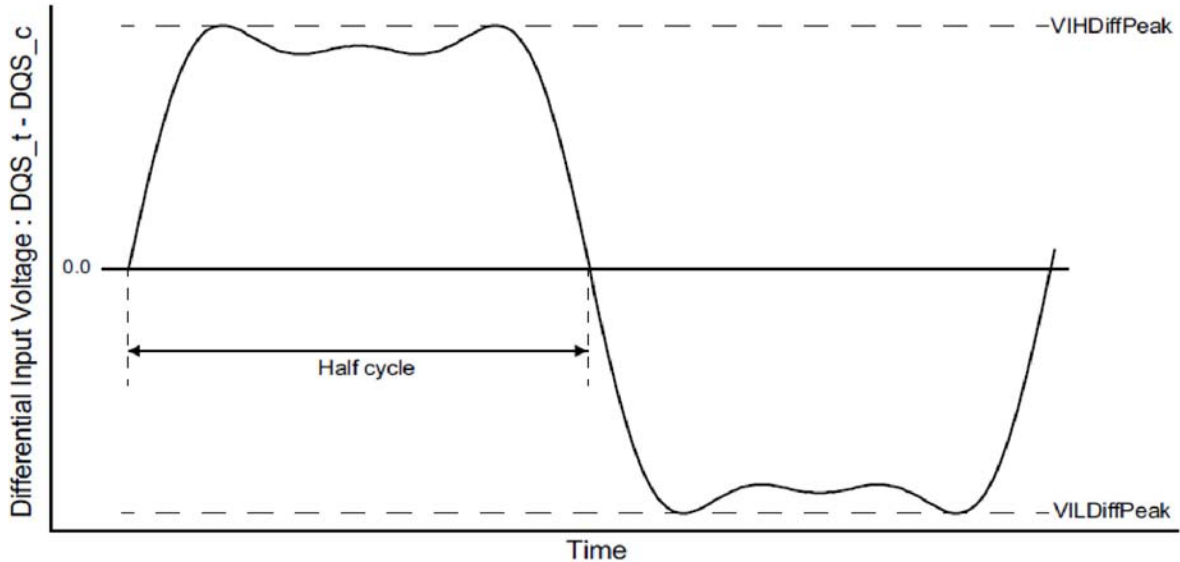

Figure 11. Definition of differential DQS Signal AC-swing Level

### 8.7.2 Differential swing requirements for DQS (DQS\_t - DQS\_c)

[ Table 17 ] Differential AC and DC Input Levels for DQS

Symbol	Parameter	DDR4-1600/1866/2133		DDR4-2400		DDR4-2666		Unit	Note
		Min	Max	Min	Max	Min	Max		
VIHDiffPeak	VIH.DIFF.Peak Voltage	186	Note2	160	Note2	TBD	TBD	mV	1
VILDiffPeak	VIL.DIFF.Peak Voltage	Note2	-186	Note2	-160	TBD	TBD	mV	1

- NOTE :**
- Used to define a differential signal slew-rate.
  - These values are not defined; however, the differential signals DQS\_t - DQS\_c, need to be within the respective limits Overshoot, Undershoot Specification for single-ended signals.

### 8.7.3 Peak voltage calculation method

The peak voltage of Differential DQS signals are calculated in a following equation.

$$VIH.DIFF.Peak Voltage = \text{Max}(f(t))$$

$$VIL.DIFF.Peak Voltage = \text{Min}(f(t))$$

$$f(t) = VDQS\_t - VDQS\_c$$

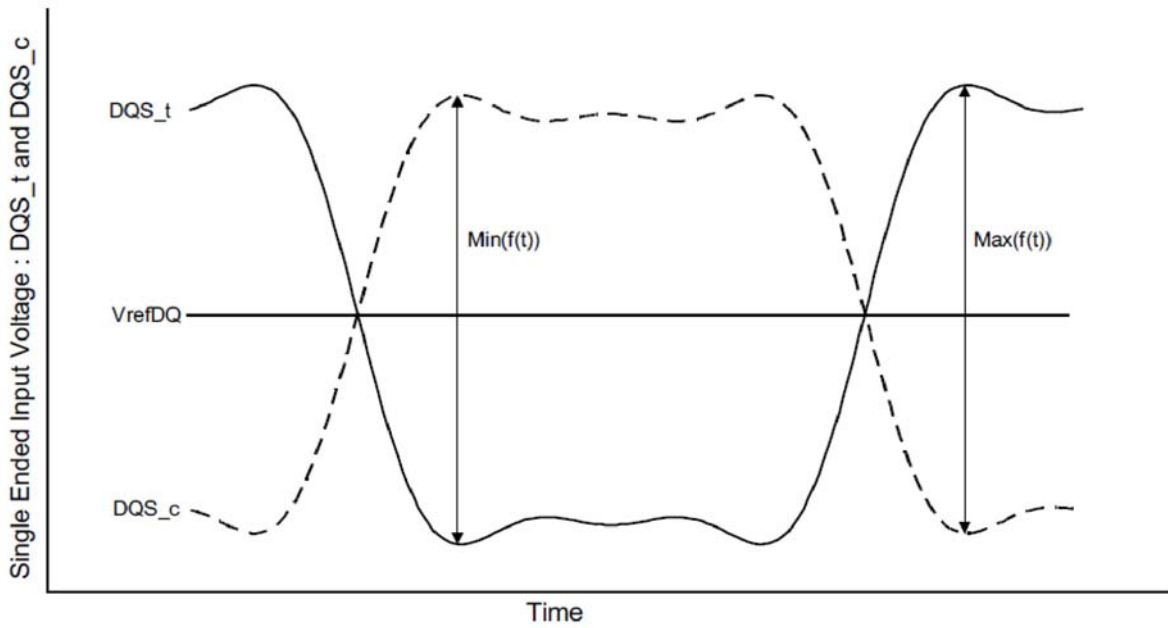

Figure 12. Definition of differential DQS Peak Voltage

### 8.7.4 Differential Input Cross Point Voltage

To guarantee tight setup and hold times as well as output skew parameters with respect to strobe, the cross point voltage of differential input signals (DQS\_t, DQS\_c) must meet the requirements in Table 18. The differential input cross point voltage VIX is measured from the actual cross point of true and complement signals to the mid level that is VrefDQ. Vix Definition (DQS)

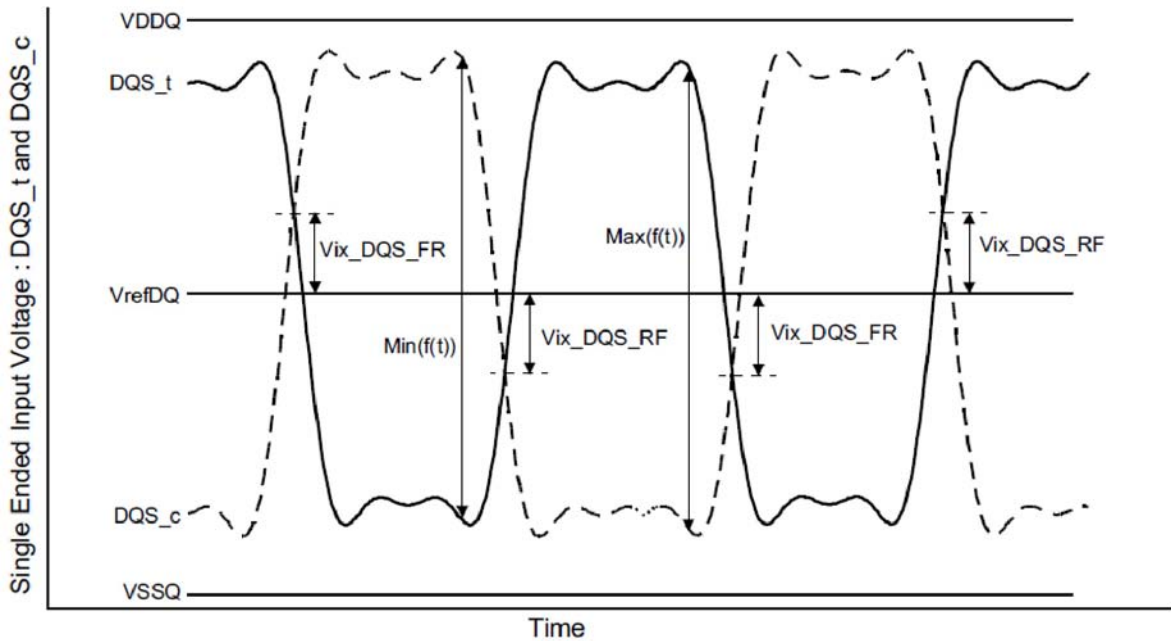

Figure 13. Vix Definition (DQS)

[ Table 18 ] Cross point voltage for differential input signals (DQS)

Symbol	Parameter	DDR4-1600/1866/2133/2400		DDR4-2666		Unit	Note
		Min	Max	Min	Max		
Vix_DQS_ratio	DQS Differential input crosspoint voltage ratio	-	25	TBD	TBD	%	1, 2, 3

- NOTE :
1. The base level of Vix\_DQS\_FR/RF is VrefDQ that is DDR4 SDRAM internal setting value by Vref Training.
  2. Vix\_DQS\_FR is defined by this equation :  $Vix\_DQS\_FR = |\text{Min}(f(t)) \times Vix\_DQS\_Ratio|$
  3. Vix\_DQS\_RF is defined by this equation :  $Vix\_DQS\_RF = \text{Max}(f(t)) \times Vix\_DQS\_Ratio$

### 8.7.5 Differential Input Slew Rate Definition

Input slew rate for differential signals (DQS\_t, DQS\_c) are defined and measured as shown in are Figure 11 and Figure 12.

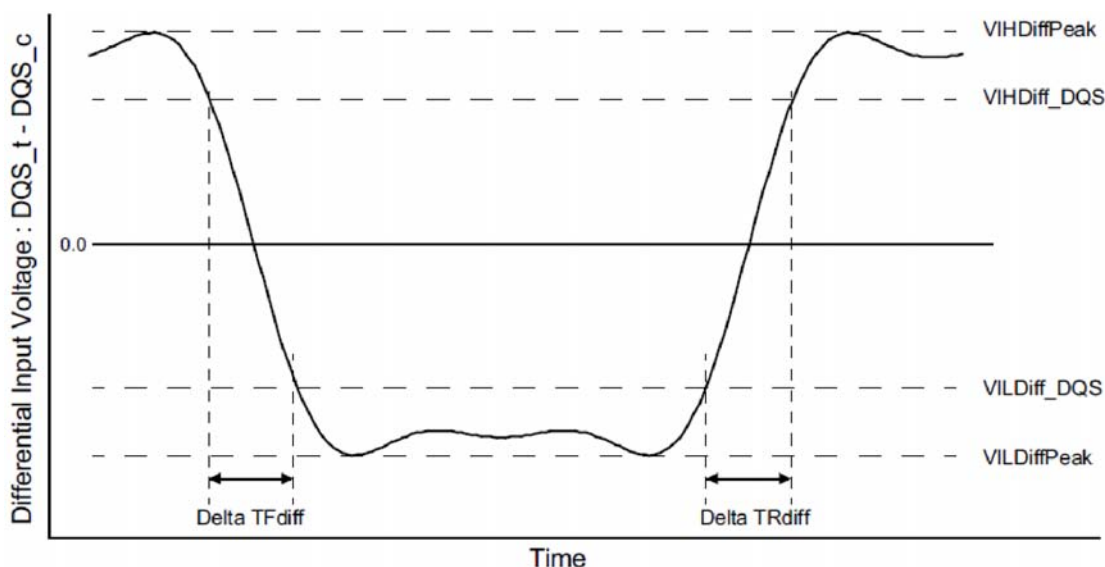

- NOTE :
1. Differential signal rising edge from VILDif\_DQS to VIHDiff\_DQS must be monotonic slope.
  2. Differential signal falling edge from VIHDiff\_DQS to VILDif\_DQS must be monotonic slope.

Figure 14. Differential Input Slew Rate Definition for DQS\_t, DQS\_c

[ Table 19 ] Differential Input Slew Rate Definition for DQS\_t, DQS\_c

Description	From	To	Defined by
Differential input slew rate for rising edge(DQS_t - DQS_c)	VILDif_DQS	VIHDiff_DQS	$ VILDif\_DQS - VIHDiff\_DQS  / \Delta TRdiff$
Differential input slew rate for falling edge(DQS_t - DQS_c)	VIHDiff_DQS	VILDif_DQS	$ VILDif\_DQS - VIHDiff\_DQS  / \Delta TFdiff$

[ Table 20 ] Differential Input Level for DQS\_t, DQS\_c

Symbol	Parameter	DDR4-1600/1866/2133		DDR4-2400		DDR4-2666		Unit	NOTE
		Min	Max	Min	Max	Min	Max		
VIHDiff_DQS	Differential Input High	136	-	130	-	TBD	TBD	mV	
VILDif_DQS	Differential Input Low	-	-136	-	-130	TBD	TBD	mV	

[ Table 21 ] Differential Input Slew Rate for DQS\_t, DQS\_c

Symbol	Parameter	DDR4-1600/1866/2133/2400		DDR4-2666		Unit	NOTE
		Min	Max	Min	Max		
SRIdiff	Differential Input Slew Rate	3	18	TBD	TBD	V/ns	

## 9. AC and DC output Measurement levels

### 9.1 Output Driver DC Electrical Characteristics

The DDR4 driver supports two different Ron values. These Ron values are referred as strong(low Ron) and weak mode(high Ron). A functional representation of the output buffer is shown in the figure below. Output driver impedance RON is defined as follows:

The individual pull-up and pull-down resistors (RON<sub>Pu</sub> and RON<sub>Pd</sub>) are defined as follows:

$$RON_{Pu} = \frac{VDDQ - V_{out}}{|I_{out}|} \quad \text{under the condition that } RON_{Pd} \text{ is off}$$

$$RON_{Pd} = \frac{V_{out}}{|I_{out}|} \quad \text{under the condition that } RON_{Pu} \text{ is off}$$

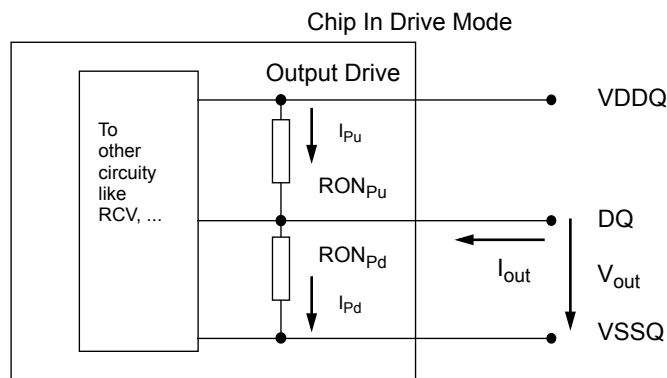

Figure 15. Output driver

[ Table 22 ] Output Driver DC Electrical Characteristics, assuming RZQ=240ohm; entire operating temperature range; after proper ZQ calibration

RON <sub>NOM</sub>	Resistor	Vout	Min	Nom	Max	Unit	NOTE
34Ω	RON34Pd	VOLdc= 0.5*VDDQ	0.8	1	1.1	RZQ/7	1,2
		VOMdc= 0.8* VDDQ	0.9	1	1.1	RZQ/7	1,2
		VOHdc= 1.1* VDDQ	0.9	1	1.25	RZQ/7	1,2
	RON34Pu	VOLdc= 0.5* VDDQ	0.9	1	1.25	RZQ/7	1,2
		VOMdc= 0.8* VDDQ	0.9	1	1.1	RZQ/7	1,2
		VOHdc= 1.1* VDDQ	0.8	1	1.1	RZQ/7	1,2
48Ω	RON48Pd	VOLdc= 0.5*VDDQ	0.8	1	1.1	RZQ/5	1,2
		VOMdc= 0.8* VDDQ	0.9	1	1.1	RZQ/5	1,2
		VOHdc= 1.1* VDDQ	0.9	1	1.25	RZQ/5	1,2
	RON48Pu	VOLdc= 0.5* VDDQ	0.9	1	1.25	RZQ/5	1,2
		VOMdc= 0.8* VDDQ	0.9	1	1.1	RZQ/5	1,2
		VOHdc= 1.1* VDDQ	0.8	1	1.1	RZQ/5	1,2
Mismatch between pull-up and pull-down, MMPuPd		VOMdc= 0.8* VDDQ	-10	-	10	%	1,2,3,4
Mismatch DQ-DQ within byte variation pull-up, MMPudd		VOMdc= 0.8* VDDQ	-	-	10	%	1,2,4
Mismatch DQ-DQ within byte variation pull-dn, MMPddd		VOMdc= 0.8* VDDQ	-	-	10	%	1,2,4

**NOTE :**

1. The tolerance limits are specified after calibration with stable voltage and temperature. For the behavior of the tolerance limits if temperature or voltage changes after calibration, see following section on voltage and temperature sensitivity(TBD).

2. Pull-up and pull-dn output driver impedances are recommended to be calibrated at 0.8 \* VDDQ. Other calibration schemes may be used to achieve the linearity spec shown above, e.g. calibration at 0.5 \* VDDQ and 1.1 \* VDDQ.

3. Measurement definition for mismatch between pull-up and pull-down, MMPuPd : Measure RONPu and RONPD both at 0.8\*VDD separately; Ronnom is the nominal Ron value

$$MMPuPd = \frac{RONPu - RONPd}{RONNOM} * 100$$

4. RON variance range ratio to RON Nominal value in a given component, including DQS\_t and DQS\_c.

$$MMPudd = \frac{RONPuMax - RONPuMin}{RONNOM} * 100$$

$$MMPddd = \frac{RONPdMax - RONPdMin}{RONNOM} * 100$$

5. This parameter of x16 device is specified for Uper byte and Lower byte.

### 9.1.1 Alert\_n output Drive Characteristic

A functional representation of the output buffer is shown in the figure below. Output driver impedance RON is defined as follows:

$$RON_{Pd} = \frac{V_{out}}{|I_{out}|} \text{ under the condition that } RON_{Pu} \text{ is off}$$

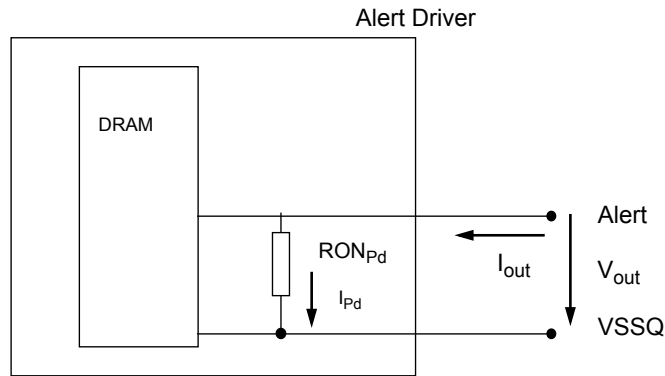

Resistor	Vout	Min	Max	Unit	NOTE
RONPd	VOLdc = 0.1 * VDDQ	0.3	1.2	34Ω	1
	VOMdc = 0.8 * VDDQ	0.4	1.2	34Ω	1
	VOHdc = 1.1 * VDDQ	0.4	1.4	34Ω	1

NOTE :  
 1. VDDQ voltage is at VDDQ DC. VDDQ DC definition is TBD.

### 9.1.2 Output Driver Characteristic of Connectivity Test ( CT ) Mode

Following Output driver impedance RON will be applied Test Output Pin during Connectivity Test ( CT ) Mode. The individual pull-up and pull-down resistors (RONPu\_CT and RONPd\_CT) are defined as follows:

$$RON_{Pu\_CT} = \frac{V_{DDQ} - V_{OUT}}{|I_{out}|}$$

$$RON_{Pd\_CT} = \frac{V_{OUT}}{|I_{out}|}$$

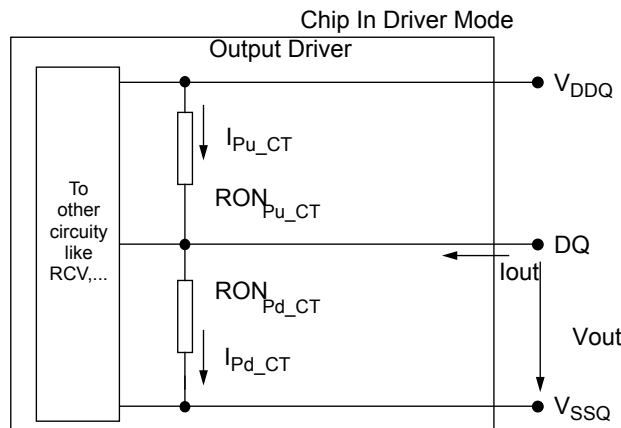

Figure 16. Output Driver

RON <sub>NOM_CT</sub>	Resistor	Vout	Max	Units	NOTE
34Ω	RON <sub>Pd_CT</sub>	$V_{OB_{dc}} = 0.2 \times V_{DDQ}$	1.9	34Ω	1
		$V_{OL_{dc}} = 0.5 \times V_{DDQ}$	2.0	34Ω	1
		$V_{OM_{dc}} = 0.8 \times V_{DDQ}$	2.2	34Ω	1
		$V_{OH_{dc}} = 1.1 \times V_{DDQ}$	2.5	34Ω	1
	RON <sub>Pu_CT</sub>	$V_{OB_{dc}} = 0.2 \times V_{DDQ}$	2.5	34Ω	1
		$V_{OL_{dc}} = 0.5 \times V_{DDQ}$	2.2	34Ω	1
		$V_{OM_{dc}} = 0.8 \times V_{DDQ}$	2.0	34Ω	1
		$V_{OH_{dc}} = 1.1 \times V_{DDQ}$	1.9	34Ω	1

**NOTE :**

1. Connectivity test mode uses un-calibrated drivers, showing the full range over PVT. No mismatch between pull up and pull down is defined.

## 9.2 Single-ended AC & DC Output Levels

[ Table 23 ] Single-ended AC & DC output levels

Symbol	Parameter	DDR4-1600/1866/2133/2400/2666	Units	NOTE
$V_{OH(DC)}$	DC output high measurement level (for IV curve linearity)	$1.1 \times V_{DDQ}$	V	
$V_{OM(DC)}$	DC output mid measurement level (for IV curve linearity)	$0.8 \times V_{DDQ}$	V	
$V_{OL(DC)}$	DC output low measurement level (for IV curve linearity)	$0.5 \times V_{DDQ}$	V	
$V_{OH(AC)}$	AC output high measurement level (for output SR)	$(0.7 + 0.15) \times V_{DDQ}$	V	1
$V_{OL(AC)}$	AC output low measurement level (for output SR)	$(0.7 - 0.15) \times V_{DDQ}$	V	1

**NOTE :**

1. The swing of  $\pm 0.15 \times V_{DDQ}$  is based on approximately 50% of the static single-ended output peak-to-peak swing with a driver impedance of  $RZQ/7\Omega$  and an effective test load of  $50\Omega$  to  $V_{TT} = V_{DDQ}$ .

## 9.3 Differential AC & DC Output Levels

[ Table 24 ] Differential AC & DC output levels

Symbol	Parameter	DDR4-1600/1866/2133/2400/2666	Units	NOTE
$V_{OHdiff(AC)}$	AC differential output high measurement level (for output SR)	$+0.3 \times V_{DDQ}$	V	1
$V_{OLdiff(AC)}$	AC differential output low measurement level (for output SR)	$-0.3 \times V_{DDQ}$	V	1

**NOTE :**

1. The swing of  $\pm 0.3 \times V_{DDQ}$  is based on approximately 50% of the static differential output peak-to-peak swing with a driver impedance of  $RZQ/7\Omega$  and an effective test load of  $50\Omega$  to  $V_{TT} = V_{DDQ}$  at each of the differential outputs.

### 9.4 Single-ended Output Slew Rate

With the reference load for timing measurements, output slew rate for falling and rising edges is defined and measured between  $V_{OL(AC)}$  and  $V_{OH(AC)}$  for single ended signals as shown in Table 25 and Figure 17.

[ Table 25 ] Single-ended output slew rate definition

Description	Measured		Defined by
	From	To	
Single ended output slew rate for rising edge	$V_{OL(AC)}$	$V_{OH(AC)}$	$[V_{OH(AC)}-V_{OL(AC)}] / \Delta TR_{se}$
Single ended output slew rate for falling edge	$V_{OH(AC)}$	$V_{OL(AC)}$	$[V_{OH(AC)}-V_{OL(AC)}] / \Delta TF_{se}$

**NOTE :**  
 1. Output slew rate is verified by design and characterization, and may not be subject to production test.

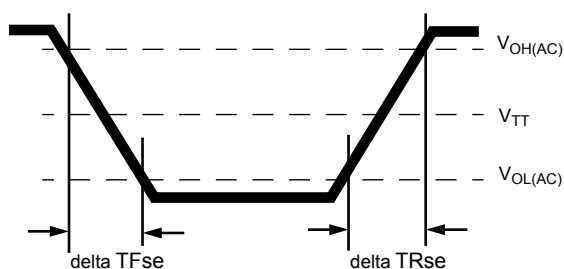

Figure 17. Single-ended Output Slew Rate Definition

[ Table 26 ] Single-ended output slew rate

Parameter	Symbol	DDR4-1600		DDR4-1866		DDR4-2133		DDR4-2400		DDR4-2666		Units
		Min	Max	Min	Max	Min	Max	Min	Max	Min	Max	
Single ended output slew rate	SRQse	4	9	4	9	4	9	4	9	TBD	TBD	V/ns

Description: SR: Slew Rate  
 Q: Query Output (like in DQ, which stands for Data-in, Query-Output)  
 se: Single-ended Signals  
 For Ron = RZQ/7 setting

**NOTE :**  
 1. In two cases, a maximum slew rate of 12 V/ns applies for a single DQ signal within a byte lane.  
 -Case 1 is defined for a single DQ signal within a byte lane which is switching into a certain direction (either from high to low or low to high) while all remaining DQ signals in the same byte lane are static (i.e. they stay at either high or low).  
 -Case 2 is defined for a single DQ signal within a byte lane which is switching into a certain direction (either from high to low or low to high) while all remaining DQ signals in the same byte lane are switching into the opposite direction (i.e. from low to high or high to low respectively). For the remaining DQ signal switching into the opposite direction, the regular maximum limit of 9 V/ns applies

## 9.5 Differential Output Slew Rate

With the reference load for timing measurements, output slew rate for falling and rising edges is defined and measured between VOLdiff(AC) and VOHdiff(AC) for differential signals as shown in Table 27 and Figure 18.

[ Table 27 ] Differential output slew rate definition

Description	Measured		Defined by
	From	To	
Differential output slew rate for rising edge	VOHdiff(AC)	VOLdiff(AC)	$[V_{OHdiff(AC)} - V_{OLdiff(AC)}] / \Delta TR_{diff}$
Differential output slew rate for falling edge	VOLdiff(AC)	VOHdiff(AC)	$[V_{OHdiff(AC)} - V_{OLdiff(AC)}] / \Delta TF_{diff}$

**NOTE :**

1. Output slew rate is verified by design and characterization, and may not be subject to production test.

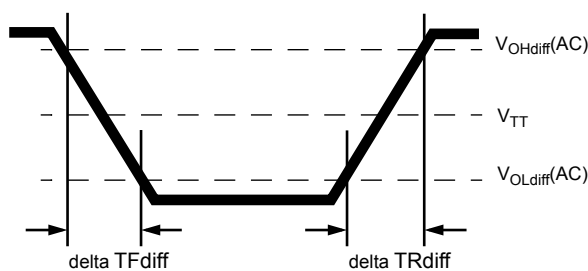

Figure 18. Differential Output Slew Rate Definition

[ Table 28 ] Differential output slew rate

Parameter	Symbol	DDR4-1600		DDR4-1866		DDR4-2133		DDR4-2400		DDR4-2666		Units
		Min	Max	Min	Max	Min	Max	Min	Max	Min	Max	
Differential output slew rate	SRQdiff	8	18	8	18	8	18	8	18	TBD	TBD	V/ns

Description:

SR: Slew Rate

Q: Query Output (like in DQ, which stands for Data-in, Query-Output)

diff: Differential Signals

For Ron = RZQ/7 setting

### 9.6 Single-ended AC & DC Output Levels of Connectivity Test Mode

Following output parameters will be applied for DDR4 SDRAM Output Signal during Connectivity Test Mode.

[ Table 29 ] Single-ended AC & DC output levels of Connectivity Test Mode

Symbol	Parameter	DDR4-1600/1866/2133 /2400/2666	Unit	Notes
$V_{OH(DC)}$	DC output high measurement level (for IV curve linearity)	$1.1 \times V_{DDQ}$	V	
$V_{OM(DC)}$	DC output mid measurement level (for IV curve linearity)	$0.8 \times V_{DDQ}$	V	
$V_{OL(DC)}$	DC output low measurement level (for IV curve linearity)	$0.5 \times V_{DDQ}$	V	
$V_{OB(DC)}$	DC output below measurement level (for IV curve linearity)	$0.2 \times V_{DDQ}$	V	
$V_{OH(AC)}$	AC output high measurement level (for output SR)	$V_{TT} + (0.1 \times V_{DDQ})$	V	1
$V_{OL(AC)}$	AC output below measurement level (for output SR)	$V_{TT} - (0.1 \times V_{DDQ})$	V	1

**NOTE**

1. The effective test load is 50Ω terminated by  $V_{TT} = 0.5 \times V_{DDQ}$ .

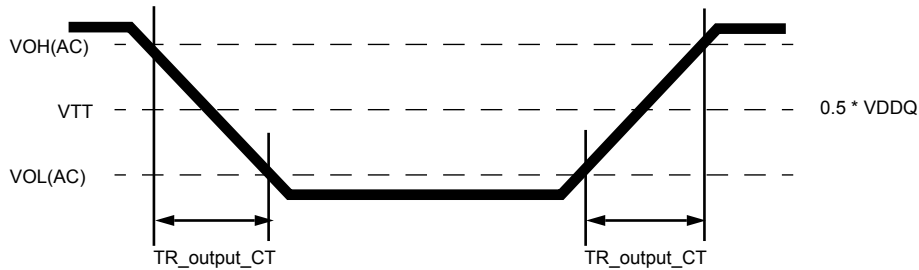

Figure 19. Output Slew Rate Definition of Connectivity Test Mode

[ Table 30 ] Single-ended output slew rate of Connectivity Test Mode

Parameter	Symbol	DDR4-1600/1866/2133/2400/2666		Unit	Notes
		Min	Max		
Output signal Falling time	$TF_{output\_CT}$	-	10	ns/V	
Output signal Rising time	$TR_{output\_CT}$	-	10	ns/V	

### 9.7 Test Load for Connectivity Test Mode Timing

The reference load for ODT timings is defined in Figure 18.

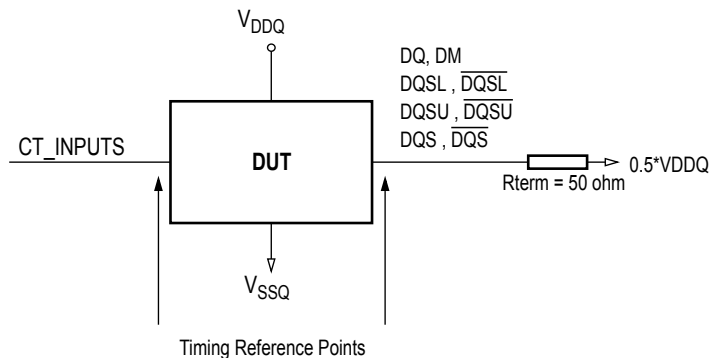

Figure 20. Connectivity Test Mode Timing Reference Load

## 10. Speed Bin

[ Table 31 ] DDR4-1600 Speed Bins and Operations

Speed Bin			DDR4-1600		Unit	NOTE	
CL-nRCD-nRP			11-11-11				
Parameter	Symbol		min	max			
Internal read command to first data	tAA		13.75 <sup>12</sup> (13.50) <sup>5,10</sup>	18.00	ns	11	
Internal read command to first data with read DBI enabled	tAA_DBI		tAA(min) + 2nCK	tAA(max) + 2nCK	ns	11	
ACT to internal read or write delay time	tRCD		13.75 <sup>12</sup> (13.50) <sup>5,10</sup>	-	ns	11	
PRE command period	tRP		13.75 <sup>12</sup> (13.50) <sup>5,10</sup>	-	ns	11	
ACT to PRE command period	tRAS		35	9 x tREFI	ns	11	
ACT to ACT or REF command period	tRC		48.75 (48.50) <sup>5,10</sup>	-	ns	11	
	Normal	Read DBI					
CWL = 9	CL = 9	CL = 11	tCK(AVG)	1.5 (Optional) <sup>5,10</sup>	1.6	ns	1,2,3,4,10,13
	CL = 10	CL = 12	tCK(AVG)	Reserved		ns	1,2,3,4,10
CWL = 9,11	CL = 10	CL = 12	tCK(AVG)	Reserved		ns	1,2,3,4
	CL = 11	CL = 13	tCK(AVG)	1.25	<1.5	ns	1,2,3,4
	CL = 12	CL = 14	tCK(AVG)	1.25	<1.5	ns	1,2,3
Supported CL Settings			9,11,12		nCK	12,13	
Supported CL Settings with read DBI			11,13,14		nCK	13	
Supported CWL Settings			9,11		nCK		

[ Table 32 ] DDR4-1866 Speed Bins and Operations

Speed Bin			DDR4-1866		Unit	NOTE	
CL-nRCD-nRP			13-13-13				
Parameter	Symbol		min	max			
Internal read command to first data	tAA		13.92 <sup>12</sup> (13.50) <sup>5,10</sup>	18.00	ns	11	
Internal read command to first data with read DBI enabled	tAA_DBI		tAA(min) + 2nCK	tAA(max) + 2nCK	ns	11	
ACT to internal read or write delay time	tRCD		13.92 <sup>12</sup> (13.50) <sup>5,10</sup>	-	ns	11	
PRE command period	tRP		13.92 <sup>12</sup> (13.50) <sup>5,10</sup>	-	ns	11	
ACT to PRE command period	tRAS		34	9 x tREFI	ns	11	
ACT to ACT or REF command period	tRC		47.92 (47.50) <sup>5,10</sup>	-	ns	11	
	Normal	Read DBI					
CWL = 9	CL = 9	CL = 11	tCK(AVG)	1.5	1.6	ns	1,2,3,4,10,13
				(Optional) <sup>5,10</sup>			
	CL = 10	CL = 12	tCK(AVG)	Reserved		ns	1,2,3,4,10
	CL = 10	CL = 12	tCK(AVG)	Reserved		ns	4
CWL = 9,11	CL = 11	CL = 13	tCK(AVG)	1.25	<1.5	ns	1,2,3,4,6
				(Optional) <sup>5,10</sup>			
	CL = 12	CL = 14	tCK(AVG)	1.25	<1.5	ns	1,2,3,6
CWL = 10,12	CL = 12	CL = 14	tCK(AVG)	Reserved		ns	1,2,3,4
	CL = 13	CL = 15	tCK(AVG)	1.071	<1.25	ns	1,2,3,4
	CL = 14	CL = 16	tCK(AVG)	1.071	<1.25	ns	1,2,3
Supported CL Settings			9,11,12,13,14		nCK	12,13	
Supported CL Settings with read DBI			11,13,14,15,16		nCK	13	
Supported CWL Settings			9,10,11,12		nCK		

[ Table 33 ] DDR4-2133 Speed Bins and Operations

Speed Bin			DDR4-2133		Unit	NOTE	
CL-nRCD-nRP			15-15-15				
Parameter	Symbol		min	max			
Internal read command to first data	tAA		14.06 <sup>12</sup> (13.75) <sup>5,10</sup>	18.00	ns	11	
Internal read command to first data with read DBI enabled	tAA_DBI		tAA(min) + 3nCK	tAA(max) + 3nCK	ns	11	
ACT to internal read or write delay time	tRCD		14.06 (13.75) <sup>5,10</sup>	-	ns	11	
PRE command period	tRP		14.06 (13.75) <sup>5,10</sup>	-	ns	11	
ACT to PRE command period	tRAS		33	9 x tREFI	ns	11	
ACT to ACT or REF command period	tRC		47.06 (46.75) <sup>5,10</sup>	-	ns	11	
	Normal	Read DBI					
CWL = 9	CL = 9	CL = 11	tCK(AVG)	1.5 (Optional) <sup>5,10</sup>	1.6	ns	1,2,3,4,10,12
	CL = 10	CL = 12	tCK(AVG)	Reserved		ns	1,2,3,10
CWL = 9,11	CL = 11	CL = 13	tCK(AVG)	1.25 (Optional) <sup>5,10</sup>	<1.5	ns	1,2,3,4,7
	CL = 12	CL = 14	tCK(AVG)	1.25	<1.5	ns	1,2,3,7
CWL = 10,12	CL = 13	CL = 15	tCK(AVG)	1.071 (Optional) <sup>5,10</sup>	<1.25	ns	1,2,3,4,7
	CL = 14	CL = 16	tCK(AVG)	1.071	<1.25	ns	1,2,3,7
CWL = 11,14	CL = 14	CL = 17	tCK(AVG)	Reserved		ns	1,2,3,4
	CL = 15	CL = 18	tCK(AVG)	0.937	<1.071	ns	1,2,3,4
	CL = 16	CL = 19	tCK(AVG)	0.937	<1.071	ns	1,2,3
Supported CL Settings			9,11,12,13,14,15,16		nCK	12,13	
Supported CL Settings with read DBI			11,13,14,15,16,18,19		nCK		
Supported CWL Settings			9,10,11,12,14		nCK		

[ Table 34 ] DDR4-2400 Speed Bins and Operations

Speed Bin			DDR4-2400		Unit	NOTE
CL-nRCD-nRP			17-17-17			
Parameter	Symbol		min	max		
Internal read command to first data	tAA		14.16 (13.75) <sup>5,10</sup>	18.00	ns	11
Internal read command to first data with read DBI enabled	tAA_DBI		tAA(min) + 3nCK	tAA(max) + 3nCK	ns	11
ACT to internal read or write delay time	tRCD		14.16 (13.75) <sup>5,10</sup>	-	ns	11
PRE command period	tRP		14.16 (13.75) <sup>5,10</sup>	-	ns	11
ACT to PRE command period	tRAS		32	9 x tREFI	ns	11
ACT to ACT or REF command period	tRC		46.16 (45.75) <sup>5,10</sup>	-	ns	11
	Normal	Read DBI				
CWL = 9	CL = 9	CL = 11	tCK(AVG)	Reserved	ns	1,2,3,4,10
	CL = 10	CL = 12	tCK(AVG)	1.5                      1.6	ns	1,2,3,4,10
CWL = 9,11	CL = 10	CL = 12	tCK(AVG)	Reserved	ns	4
	CL = 11	CL = 13	tCK(AVG)	1.25                      <1.5 (Optional) <sup>5,10</sup>	ns	1,2,3,4,8
	CL = 12	CL = 14	tCK(AVG)	1.25                      <1.5	ns	1,2,3,8
CWL = 10,12	CL = 12	CL = 14	tCK(AVG)	Reserved	ns	4
	CL = 13	CL = 15	tCK(AVG)	1.071                      <1.25 (Optional) <sup>5,10</sup>	ns	1,2,3,4,8
	CL = 14	CL = 16	tCK(AVG)	1.071                      <1.25	ns	1,2,3,8
CWL = 11,14	CL = 14	CL = 17	tCK(AVG)	Reserved	ns	4
	CL = 15	CL = 18	tCK(AVG)	0.938                      <1.071 (Optional) <sup>5,10</sup>	ns	1,2,3,4,8
	CL = 16	CL = 19	tCK(AVG)	0.938                      <1.071	ns	1,2,3,8
CWL = 12,16	CL = 15	CL = 18	tCK(AVG)	Reserved	ns	1,2,3,4
	CL = 16	CL = 19	tCK(AVG)	Reserved	ns	1,2,3,4
	CL = 17	CL = 20	tCK(AVG)	0.833                      <0.937		
	CL = 18	CL = 21	tCK(AVG)	0.833                      <0.937	ns	1,2,3
Supported CL Settings			10,11,12,13,14,15,16,17,18		nCK	12
Supported CL Settings with read DBI			12,13,14,15,16,18,19,20,21		nCK	
Supported CWL Settings			9,10,11,12,14,16		nCK	

[ Table 35 ] DDR4-2666 Speed Bins and Operations

Speed Bin			DDR4-2666		Unit	NOTE
CL-nRCD-nRP			19-19-19			
Parameter	Symbol		min	max		
Internal read command to first data	tAA		14.25 <sup>13</sup> (13.75) <sup>5,11</sup>	18.00	ns	11
Internal read command to first data with read DBI enabled	tAA_DBI		tAA(min) + 3nCK	tAA(max) + 3nCK	ns	11
ACT to internal read or write delay time	tRCD		14.25 (13.75) <sup>5,11</sup>	-	ns	11
PRE command period	tRP		14.25 <sup>13</sup> (13.75) <sup>5,11</sup>	-	ns	11
ACT to PRE command period	tRAS		32	9 x tREFI	ns	11
ACT to ACT or REF command period	tRC		46.25 (45.75) <sup>5,11</sup>	-	ns	11
	Normal	Read DBI				
CWL = 9	CL = 9	CL = 11	tCK(AVG)	Reserved	ns	1,2,3,4,11
	CL = 10	CL = 12	tCK(AVG)	1.5                      1.6	ns	1,2,3,11
CWL = 9,11	CL = 10	CL = 12	tCK(AVG)	Reserved	ns	4
	CL = 11	CL = 13	tCK(AVG)	1.25                      <1.5 (Optional) <sup>5,11</sup>	ns	1,2,3,4,9
	CL = 12	CL = 14	tCK(AVG)	1.25                      <1.5	ns	1,2,3,9
CWL = 10,12	CL = 12	CL = 14	tCK(AVG)	Reserved	ns	4
	CL = 13	CL = 15	tCK(AVG)	1.071                      <1.25 (Optional) <sup>5,11</sup>	ns	1,2,3,4,9
	CL = 14	CL = 16	tCK(AVG)	1.071                      <1.25	ns	1,2,3,9
CWL = 11,14	CL = 14	CL = 17	tCK(AVG)	Reserved	ns	4
	CL = 15	CL = 18	tCK(AVG)	0.937                      <1.071 (Optional) <sup>5,11</sup>	ns	1,2,3,4,9
	CL = 16	CL = 19	tCK(AVG)	0.937                      <1.071	ns	1,2,3,9
CWL = 12,16	CL = 15	CL = 18	tCK(AVG)	Reserved	ns	4
	CL = 16	CL = 19	tCK(AVG)	Reserved	ns	1,2,3,4,9
	CL = 17	CL = 20	tCK(AVG)	0.833                      <0.937 (Optional) <sup>5,11</sup>	ns	1,2,3,4,9
	CL = 18	CL = 21	tCK(AVG)	0.833                      <0.937	ns	1,2,3
CWL = 14,18	CL = 17	CL = 20	tCK(AVG)	Reserved	ns	1,2,3,4
	CL = 18	CL = 21	tCK(AVG)	Reserved	ns	1,2,3,4
	CL = 19	CL = 22	tCK(AVG)	0.75                      <0.833	ns	1,2,3,4
	CL = 20	CL = 23	tCK(AVG)	0.75                      <0.833	ns	1,2,3
Supported CL Settings			10,11,12,13,14,15,16,17,18,19,20		nCK	12
Supported CL Settings with read DBI			12,13,14,15,17,18,19,20,21,22,23		nCK	
Supported CWL Settings			9,10,11,12,14,16,18		nCK	

## 10.1 Speed Bin Table Note

### Absolute Specification

- VDDQ = VDD = 1.20V +/- 0.06 V
- VPP = 2.5V +0.25/-0.125 V
- The values defined with above-mentioned table are DLL ON case.
- DDR4-1600, 1866, 2133,2400 and 2666 Speed Bin Tables are valid only when Geardown Mode is disabled.

1. The CL setting and CWL setting result in tCK(avg).MIN and tCK(avg).MAX requirements. When making a selection of tCK(avg), both need to be fulfilled: Requirements from CL setting as well as requirements from CWL setting.
2. tCK(avg).MIN limits: Since CAS Latency is not purely analog - data and strobe output are synchronized by the DLL - all possible intermediate frequencies may not be guaranteed. An application should use the next smaller JEDEC standard tCK(avg) value (1.5, 1.25, 1.071, 0.938 or 0.833 ns) when calculating  $CL [nCK] = tAA [ns] / tCK(avg) [ns]$ , rounding up to the next 'Supported CL', where tAA = 12.5ns and tCK(avg) = 1.3 ns should only be used for CL = 10 calculation.
3. tCK(avg).MAX limits: Calculate  $tCK(avg) = tAA.MAX / CL SELECTED$  and round the resulting tCK(avg) down to the next valid speed bin (i.e. 1.5ns or 1.25ns or 1.071 ns or 0.938 ns or 0.833 ns). This result is tCK(avg).MAX corresponding to CL SELECTED.
4. 'Reserved' settings are not allowed. User must program a different value.
5. 'Optional' settings allow certain devices in the industry to support this setting, however, it is not a mandatory feature. Refer to supplier's data sheet and/or the DIMM SPD information if and how this setting is supported.
6. Any DDR4-1866 speed bin also supports functional operation at lower frequencies as shown in the table which are not subject to Production Tests but verified by Design/Characterization.
7. Any DDR4-2133 speed bin also supports functional operation at lower frequencies as shown in the table which are not subject to Production Tests but verified by Design/Characterization.
8. Any DDR4-2400 speed bin also supports functional operation at lower frequencies as shown in the table which are not subject to Production Tests but verified by Design/Characterization.
9. Any DDR4-2666 speed bin also supports functional operation at lower frequencies as shown in the table which are not subject to Production Tests but verified by Design/Characterization.
10. DDR4-1600 AC timing apply if DRAM operates at lower than 1600 MT/s data rate.
11. Parameters apply from tCK(avg)min to tCK(avg)max at all standard JEDEC clock period values as stated in the Speed Bin Tables.
12. CL number in parentheses, it means that these numbers are optional.
13. DDR4 SDRAM supports CL=9 as long as a system meets tAA(min).
14. Each speed bin lists the timing requirements that need to be supported in order for a given DRAM to be JEDEC compliant. JEDEC compliance does not require support for all speed bins within a given speed. JEDEC compliance requires meeting the parameters for a least one of the listed speed bins.

# 11. IDD and IDDQ Specification Parameters and Test conditions

## 11.1 IDD, IPP and IDDQ Measurement Conditions

In this chapter, IDD, IPP and IDDQ measurement conditions such as test load and patterns are defined. Figure 21 shows the setup and test load for IDD, IPP and IDDQ measurements.

- I IDD currents (such as IDD0, IDD0A, IDD1, IDD1A, IDD2N, IDD2NA, IDD2NL, IDD2NT, IDD2P, IDD2Q, IDD3N, IDD3NA, IDD3P, IDD4R, IDD4RA, IDD4W, IDD4WA, IDD5B, IDD5F2, IDD5F4, IDD6N, IDD6E, IDD6R, IDD6A, IDD7 and IDD8) are measured as time-averaged currents with all VDD balls of the DDR4 SDRAM under test tied together. Any IPP or IDDQ current is not included in IDD currents.
- I IPP currents have the same definition as IDD except that the current on the VPP supply is measured.
- I IDDQ currents (such as IDDQ2NT and IDDQ4R) are measured as time-averaged currents with all VDDQ balls of the DDR4 SDRAM under test tied together. Any IDD current is not included in IDDQ currents.  
Attention: IDDQ values cannot be directly used to calculate IO power of the DDR4 SDRAM. They can be used to support correlation of simulated IO power to actual IO power as outlined in Figure 22. In DRAM module application, IDDQ cannot be measured separately since VDD and VDDQ are using one merged-power layer in Module PCB.

For IDD, IPP and IDDQ measurements, the following definitions apply:

- I "0" and "LOW" is defined as  $V_{IN} \leq V_{ILAC(max)}$ .
- I "1" and "HIGH" is defined as  $V_{IN} \geq V_{IHAC(min)}$ .
- I "MID-LEVEL" is defined as inputs are  $V_{REF} = V_{DD} / 2$ .
- I Timings used for IDD, IPP and IDDQ Measurement-Loop Patterns are provided in Table 36.
- I Basic IDD, IPP and IDDQ Measurement Conditions are described in Table 37.
- I Detailed IDD, IPP and IDDQ Measurement-Loop Patterns are described in Table 38 through Table 46.
- I IDD Measurements are done after properly initializing the DDR4 SDRAM. This includes but is not limited to setting  
RON = RZQ/7 (34 Ohm in MR1);  
RTT\_NOM = RZQ/6 (40 Ohm in MR1);  
RTT\_WR = RZQ/2 (120 Ohm in MR2);  
RTT\_PARK = Disable;  
Qoff = 0<sub>B</sub> (Output Buffer enabled) in MR1;  
TDQS\_t disabled in MR1;  
CRC disabled in MR2;  
CA parity feature disabled in MR5;  
Gear down mode disabled in MR3  
Read/Write DBI disabled in MR5;  
DM disabled in MR5
- I Attention: The IDD, IPP and IDDQ Measurement-Loop Patterns need to be executed at least one time before actual IDD or IDDQ measurement is started.
- I Define D = {CS\_n, ACT\_n, RAS\_n, CAS\_n, WE\_n} := {HIGH, LOW, LOW, LOW, LOW} ; apply BG/BA changes when directed.
- I Define D# = {CS\_n, ACT\_n, RAS\_n, CAS\_n, WE\_n} := {HIGH, HIGH, HIGH, HIGH, HIGH} apply invert of BG/BA changes when directed above.

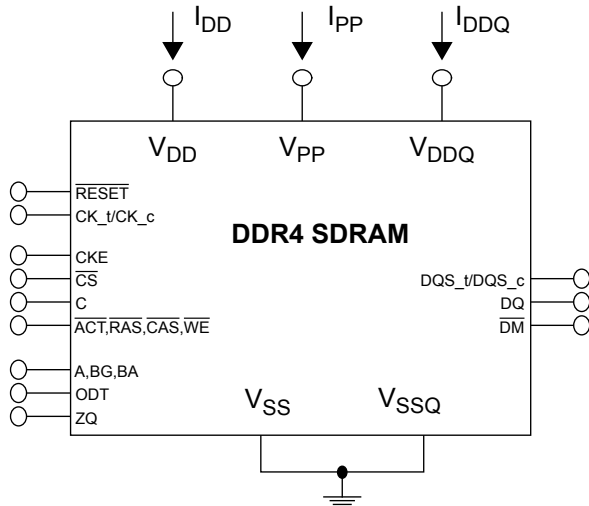

**NOTE:**  
 1. DIMM level Output test load condition may be different from above

**Figure 21. Measurement Setup and Test Load for IDD, IPP and IDDQ Measurements**

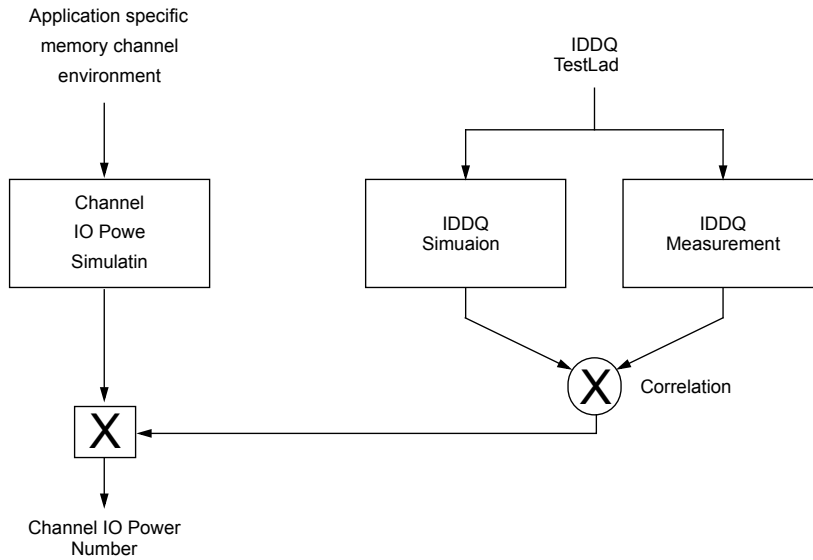

**Figure 22. Correlation from simulated Channel IO Power to actual Channel IO Power supported by IDDQ Measurement.**

[ Table 36 ] Timings used for IDD, IPP and IDDQ Measurement-Loop Patterns

Symbol		DDR4-1600	DDR4-1866	DDR4-2133	DDR4-2400	DDR4-2666	Unit
		11-11-11	13-13-13	15-15-15	17-17-17	19-19-19	
tCK		1.25	1.071	0.938	0.833	TBD	ns
CL		11	13	15	17	TBD	nCK
CWL		11	12	14	16	TBD	nCK
nRCD		11	13	15	17	TBD	nCK
nRC		39	45	51	56	TBD	nCK
nRAS		28	32	36	39	TBD	nCK
nRP		11	13	15	17	TBD	nCK
nFAW	x4	16	16	16	16	TBD	nCK
	x8	20	22	23	26	TBD	nCK
	x16	28	28	32	36	TBD	nCK
nRRDS	x4	4	4	4	4	TBD	nCK
	x8	4	4	4	4	TBD	nCK
	x16	5	5	6	7	TBD	nCK
nRRDL	x4	5	5	6	6	TBD	nCK
	x8	5	5	6	6	TBD	nCK
	x16	6	6	7	8	TBD	nCK
tCCD_S		4	4	4	4	TBD	nCK
tCCD_L		5	5	6	6	TBD	nCK
tWTR_S		2	3	3	3	TBD	nCK
tWTR_L		6	7	8	9	TBD	nCK
nRFC 2Gb		128	150	171	193	TBD	nCK
nRFC 4Gb		208	243	278	313	TBD	nCK
nRFC 8Gb		280	327	374	421	TBD	nCK
TBD							nCK

[ Table 37 ] Basic IDD, IPP and IDDQ Measurement Conditions

Symbol	Description
IDD0	<b>Operating One Bank Active-Precharge Current (AL=0)</b> <b>CKE:</b> High; <b>External clock:</b> On; <b>tCK, nRC, nRAS, CL:</b> see Table 36 on page 39; <b>BL:</b> 8 <sup>1</sup> ; <b>AL:</b> 0; <b>CS_n:</b> High between ACT and PRE; <b>Command, Address, Bank Group Address, Bank Address Inputs:</b> partially toggling according to Table 38 on page 43; <b>Data IO:</b> VDDQ; <b>DM_n:</b> stable at 1; <b>Bank Activity:</b> Cycling with one bank active at a time: 0,0,1,1,2,2,... (see Table 38 on page 43); <b>Output Buffer and RTT:</b> Enabled in Mode Registers <sup>2</sup> ; <b>ODT Signal:</b> stable at 0; <b>Pattern Details:</b> see Table 38 on page 43
IDD0A	<b>Operating One Bank Active-Precharge Current (AL=CL-1)</b> <b>AL = CL-1, Other conditions:</b> see IDD0
IPP0	<b>Operating One Bank Active-Precharge IPP Current</b> <b>Same condition with IDD0</b>
IDD1	<b>Operating One Bank Active-Read-Precharge Current (AL=0)</b> <b>CKE:</b> High; <b>External clock:</b> On; <b>tCK, nRC, nRAS, nRCD, CL:</b> see Table 36 on page 39; <b>BL:</b> 8 <sup>1</sup> ; <b>AL:</b> 0; <b>CS_n:</b> High between ACT, RD and PRE; <b>Command, Address, Bank Group Address, Bank Address Inputs, Data IO:</b> partially toggling according to Table 39 on page 44; <b>DM_n:</b> stable at 1; <b>Bank Activity:</b> Cycling with one bank active at a time: 0,0,1,1,2,2,... (see Table 39 on page 44); <b>Output Buffer and RTT:</b> Enabled in Mode Registers <sup>2</sup> ; <b>ODT Signal:</b> stable at 0; <b>Pattern Details:</b> see Table 39 on page 44
IDD1A	<b>Operating One Bank Active-Read-Precharge Current (AL=CL-1)</b> <b>AL = CL-1, Other conditions:</b> see IDD1
IPP1	<b>Operating One Bank Active-Read-Precharge IPP Current</b> <b>Same condition with IDD1</b>
IDD2N	<b>Precharge Standby Current (AL=0)</b> <b>CKE:</b> High; <b>External clock:</b> On; <b>tCK, CL:</b> see Table 36 on page 39; <b>BL:</b> 8 <sup>1</sup> ; <b>AL:</b> 0; <b>CS_n:</b> stable at 1; <b>Command, Address, Bank Group Address, Bank Address Inputs:</b> partially toggling according to Table 40 on page 45; <b>Data IO:</b> VDDQ; <b>DM_n:</b> stable at 1; <b>Bank Activity:</b> all banks closed; <b>Output Buffer and RTT:</b> Enabled in Mode Registers <sup>2</sup> ; <b>ODT Signal:</b> stable at 0; <b>Pattern Details:</b> see Table 40 on page 45
IDD2NA	<b>Precharge Standby Current (AL=CL-1)</b> <b>AL = CL-1, Other conditions:</b> see IDD2N
IPP2N	<b>Precharge Standby IPP Current</b> <b>Same condition with IDD2N</b>
IDD2NT	<b>Precharge Standby ODT Current</b> <b>CKE:</b> High; <b>External clock:</b> On; <b>tCK, CL:</b> see Table 36 on page 39; <b>BL:</b> 8 <sup>1</sup> ; <b>AL:</b> 0; <b>CS_n:</b> stable at 1; <b>Command, Address, Bank Group Address, Bank Address Inputs:</b> partially toggling according to Table 41 on page 46; <b>Data IO:</b> VSSQ; <b>DM_n:</b> stable at 1; <b>Bank Activity:</b> all banks closed; <b>Output Buffer and RTT:</b> Enabled in Mode Registers <sup>2</sup> ; <b>ODT Signal:</b> toggling according to Table 41 on page 46; <b>Pattern Details:</b> see Table 41 on page 46
IDDQ2NT (Optional)	<b>Precharge Standby ODT IDDQ Current</b> Same definition like for IDD2NT, however measuring IDDQ current instead of IDD current
IDD2NL	<b>Precharge Standby Current with CAL enabled</b> Same definition like for IDD2N, CAL enabled <sup>3,5</sup>
IDD2NG	<b>Precharge Standby Current with Gear Down mode enabled</b> Same definition like for IDD2N, Gear Down mode enabled <sup>3,5</sup>
IDD2ND	<b>Precharge Standby Current with DLL disabled</b> Same definition like for IDD2N, DLL disabled <sup>3</sup>
IDD2N_par	<b>Precharge Standby Current with CA parity enabled</b> Same definition like for IDD2N, CA parity enabled <sup>3</sup>
IDD2P	<b>Precharge Power-Down Current</b> <b>CKE:</b> Low; <b>External clock:</b> On; <b>tCK, CL:</b> see Table 36 on page 39; <b>BL:</b> 8 <sup>1</sup> ; <b>AL:</b> 0; <b>CS_n:</b> stable at 1; <b>Command, Address, Bank Group Address, Bank Address Inputs:</b> stable at 0; <b>Data IO:</b> VDDQ; <b>DM_n:</b> stable at 1; <b>Bank Activity:</b> all banks closed; <b>Output Buffer and RTT:</b> Enabled in Mode Registers <sup>2</sup> ; <b>ODT Signal:</b> stable at 0
IPP2P	<b>Precharge Power-Down IPP Current</b> <b>Same condition with IDD2P</b>
IDD2Q	<b>Precharge Quiet Standby Current</b> <b>CKE:</b> High; <b>External clock:</b> On; <b>tCK, CL:</b> see Table 36 on page 39; <b>BL:</b> 8 <sup>1</sup> ; <b>AL:</b> 0; <b>CS_n:</b> stable at 1; <b>Command, Address, Bank Group Address, Bank Address Inputs:</b> stable at 0; <b>Data IO:</b> VDDQ; <b>DM_n:</b> stable at 1; <b>Bank Activity:</b> all banks closed; <b>Output Buffer and RTT:</b> Enabled in Mode Registers <sup>2</sup> ; <b>ODT Signal:</b> stable at 0
IDD3N	<b>Active Standby Current</b> <b>CKE:</b> High; <b>External clock:</b> On; <b>tCK, CL:</b> see Table 36 on page 39; <b>BL:</b> 8 <sup>1</sup> ; <b>AL:</b> 0; <b>CS_n:</b> stable at 1; <b>Command, Address, Bank Group Address, Bank Address Inputs:</b> partially toggling according to Table 40 on page 45; <b>Data IO:</b> VDDQ; <b>DM_n:</b> stable at 1; <b>Bank Activity:</b> all banks open; <b>Output Buffer and RTT:</b> Enabled in Mode Registers <sup>2</sup> ; <b>ODT Signal:</b> stable at 0; <b>Pattern Details:</b> see Table 40 on page 45

Symbol	Description
IDD3NA	<b>Active Standby Current (AL=CL-1)</b> AL = CL-1, Other conditions: see IDD3N
IPP3N	<b>Active Standby IPP Current</b> Same condition with IDD3N
IDD3P	<b>Active Power-Down Current</b> CKE: Low; External clock: On; tCK, CL: see Table 36 on page 39; BL: 8 <sup>1</sup> ; AL: 0; CS_n: stable at 1; <b>Command, Address, Bank Group Address, Bank Address Inputs:</b> stable at 0; <b>Data IO:</b> VDDQ; <b>DM_n:</b> stable at 1; <b>Bank Activity:</b> all banks open; <b>Output Buffer and RTT:</b> Enabled in Mode Registers <sup>2</sup> ; <b>ODT Signal:</b> stable at 0
IPP3P	<b>Active Power-Down IPP Current</b> Same condition with IDD3P
IDD4R	<b>Operating Burst Read Current</b> CKE: High; External clock: On; tCK, CL: see Table 36 on page 39; BL: 8 <sup>2</sup> ; AL: 0; CS_n: High between RD; <b>Command, Address, Bank Group Address, Bank Address Inputs:</b> partially toggling according to Table 42 on page 47; <b>Data IO:</b> seamless read data burst with different data between one burst and the next one according to Table 42 on page 47; <b>DM_n:</b> stable at 1; <b>Bank Activity:</b> all banks open, RD commands cycling through banks: 0,0,1,1,2,2,... (see Table 42 on page 47); <b>Output Buffer and RTT:</b> Enabled in Mode Registers <sup>2</sup> ; <b>ODT Signal:</b> stable at 0; <b>Pattern Details:</b> see Table 42 on page 47
IDD4RA	<b>Operating Burst Read Current (AL=CL-1)</b> AL = CL-1, Other conditions: see IDD4R
IDD4RB	<b>Operating Burst Read Current with Read DBI</b> Read DBI enabled <sup>3</sup> , Other conditions: see IDD4R
IPP4R	<b>Operating Burst Read IPP Current</b> Same condition with IDD4R
IDDQ4R (Optional)	<b>Operating Burst Read IDDQ Current</b> Same definition like for IDD4R, however measuring IDDQ current instead of IDD current
IDDQ4RB (Optional)	<b>Operating Burst Read IDDQ Current with Read DBI</b> Same definition like for IDD4RB, however measuring IDDQ current instead of IDD current
IDD4W	<b>Operating Burst Write Current</b> CKE: High; External clock: On; tCK, CL: see Table 36 on page 39; BL: 8 <sup>1</sup> ; AL: 0; CS_n: High between WR; <b>Command, Address, Bank Group Address, Bank Address Inputs:</b> partially toggling according to Table 43 on page 48; <b>Data IO:</b> seamless write data burst with different data between one burst and the next one according to Table 43 on page 48; <b>DM_n:</b> stable at 1; <b>Bank Activity:</b> all banks open, WR commands cycling through banks: 0,0,1,1,2,2,... (see Table 43 on page 48); <b>Output Buffer and RTT:</b> Enabled in Mode Registers <sup>2</sup> ; <b>ODT Signal:</b> stable at HIGH; <b>Pattern Details:</b> see Table 43 on page 48
IDD4WA	<b>Operating Burst Write Current (AL=CL-1)</b> AL = CL-1, Other conditions: see IDD4W
IDD4WB	<b>Operating Burst Write Current with Write DBI</b> Write DBI enabled <sup>3</sup> , Other conditions: see IDD4W
IDD4WC	<b>Operating Burst Write Current with Write CRC</b> Write CRC enabled <sup>3</sup> , Other conditions: see IDD4W
IDD4W_par	<b>Operating Burst Write Current with CA Parity</b> CA Parity enabled <sup>3</sup> , Other conditions: see IDD4W
IPP4W	<b>Operating Burst Write IPP Current</b> Same condition with IDD4W
IDD5B	<b>Burst Refresh Current (1X REF)</b> CKE: High; External clock: On; tCK, CL, nRFC: see Table 36 on page 39; BL: 8 <sup>1</sup> ; AL: 0; CS_n: High between REF; <b>Command, Address, Bank Group Address, Bank Address Inputs:</b> partially toggling according to Table 45 on page 50; <b>Data IO:</b> VDDQ; <b>DM_n:</b> stable at 1; <b>Bank Activity:</b> REF command every nRFC (see Table 45 on page 50); <b>Output Buffer and RTT:</b> Enabled in Mode Registers <sup>2</sup> ; <b>ODT Signal:</b> stable at 0; <b>Pattern Details:</b> see Table 45 on page 50
IPP5B	<b>Burst Refresh Write IPP Current (1X REF)</b> Same condition with IDD5B
IDD5F2	<b>Burst Refresh Current (2X REF)</b> tRFC=tRFC_x2, Other conditions: see IDD5B
IPP5F2	<b>Burst Refresh Write IPP Current (2X REF)</b> Same condition with IDD5F2
IDD5F4	<b>Burst Refresh Current (4X REF)</b> tRFC=tRFC_x4, Other conditions: see IDD5B
IPP5F4	<b>Burst Refresh Write IPP Current (4X REF)</b> Same condition with IDD5F4

Symbol	Description
IDD6N	<b>Self Refresh Current: Normal Temperature Range</b> <b>T<sub>CASE</sub></b> : 0 - 85°C; <b>Low Power Array Self Refresh (LP ASR)</b> : Normal <sup>4</sup> ; <b>CKE</b> : Low; <b>External clock</b> : Off; <b>CK<sub>t</sub></b> and <b>CK<sub>c</sub></b> : LOW; <b>CL</b> : see Table 36 on page 39; <b>BL</b> : 8 <sup>1</sup> ; <b>AL</b> : 0; <b>CS<sub>n</sub></b> , <b>Command, Address, Bank Group Address, Bank Address, Data IO</b> : High; <b>DM<sub>n</sub></b> : stable at 1; <b>Bank Activity</b> : Self-Refresh operation; <b>Output Buffer and RTT</b> : Enabled in Mode Registers <sup>2</sup> ; <b>ODT Signal</b> : MID-LEVEL
IPP6N	<b>Self Refresh IPP Current: Normal Temperature Range</b> <b>Same condition with IDD6N</b>
IDD6E	<b>Self-Refresh Current: Extended Temperature Range</b> <sup>1)</sup> <b>T<sub>CASE</sub></b> : 0 - 95°C; <b>Low Power Array Self Refresh (LP ASR)</b> : Extended <sup>4</sup> ; <b>CKE</b> : Low; <b>External clock</b> : Off; <b>CK<sub>t</sub></b> and <b>CK<sub>c</sub></b> : LOW; <b>CL</b> : see Table 36 on page 39; <b>BL</b> : 8 <sup>1</sup> ; <b>AL</b> : 0; <b>CS<sub>n</sub></b> , <b>Command, Address, Bank Group Address, Bank Address, Data IO</b> : High; <b>DM<sub>n</sub></b> : stable at 1; <b>Bank Activity</b> : Extended Temperature Self-Refresh operation; <b>Output Buffer and RTT</b> : Enabled in Mode Registers <sup>2</sup> ; <b>ODT Signal</b> : MID-LEVEL
IPP6E	<b>Self Refresh IPP Current: Extended Temperature Range</b> <b>Same condition with IDD6E</b>
IDD6R	<b>Self-Refresh Current: Reduced Temperature Range</b> <b>T<sub>CASE</sub></b> : 0 - 45°C; <b>Low Power Array Self Refresh (LP ASR)</b> : Reduced <sup>4</sup> ; <b>CKE</b> : Low; <b>External clock</b> : Off; <b>CK<sub>t</sub></b> and <b>CK<sub>c</sub></b> : LOW; <b>CL</b> : see Table 36 on page 39; <b>BL</b> : 8 <sup>1</sup> ; <b>AL</b> : 0; <b>CS<sub>n</sub></b> , <b>Command, Address, Bank Group Address, Bank Address, Data IO</b> : High; <b>DM<sub>n</sub></b> : stable at 1; <b>Bank Activity</b> : Extended Temperature Self-Refresh operation; <b>Output Buffer and RTT</b> : Enabled in Mode Registers <sup>2</sup> ; <b>ODT Signal</b> : MID-LEVEL
IPP6R	<b>Self Refresh IPP Current: Reduced Temperature Range</b> <b>Same condition with IDD6R</b>
IDD6A	<b>Auto Self-Refresh Current</b> <b>T<sub>CASE</sub></b> : 0 - 95°C; <b>Low Power Array Self Refresh (LP ASR)</b> : Auto <sup>4</sup> ; <b>CKE</b> : Low; <b>External clock</b> : Off; <b>CK<sub>t</sub></b> and <b>CK<sub>c</sub></b> : LOW; <b>CL</b> : see Table 36 on page 39; <b>BL</b> : 8 <sup>1</sup> ; <b>AL</b> : 0; <b>CS<sub>n</sub></b> , <b>Command, Address, Bank Group Address, Bank Address, Data IO</b> : High; <b>DM<sub>n</sub></b> : stable at 1; <b>Bank Activity</b> : Auto Self-Refresh operation; <b>Output Buffer and RTT</b> : Enabled in Mode Registers <sup>2</sup> ; <b>ODT Signal</b> : MID-LEVEL
IPP6A	<b>Auto Self-Refresh IPP Current</b> <b>Same condition with IDD6A</b>
IDD7	<b>Operating Bank Interleave Read Current</b> <b>CKE</b> : High; <b>External clock</b> : On; <b>tCK</b> , <b>nRC</b> , <b>nRAS</b> , <b>nRCD</b> , <b>nRRD</b> , <b>nFAW</b> , <b>CL</b> : see Table 36 on page 39; <b>BL</b> : 8 <sup>1</sup> ; <b>AL</b> : CL-1; <b>CS<sub>n</sub></b> : High between ACT and RDA; <b>Command, Address, Bank Group Address, Bank Address Inputs</b> : partially toggling according to Table 46 on page 51; <b>Data IO</b> : read data bursts with different data between one burst and the next one according to Table 46 on page 51; <b>DM<sub>n</sub></b> : stable at 1; <b>Bank Activity</b> : two times interleaved cycling through banks (0, 1, ...7) with different addressing, see Table 46 on page 51; <b>Output Buffer and RTT</b> : Enabled in Mode Registers <sup>2</sup> ; <b>ODT Signal</b> : stable at 0; <b>Pattern Details</b> : see Table 46 on page 51
IPP7	<b>Operating Bank Interleave Read IPP Current</b> <b>Same condition with IDD7</b>
IDD8	<b>Maximum Power Down Current</b> <b>TBD</b>
IPP8	<b>Maximum Power Down IPP Current</b> <b>Same condition with IDD8</b>

**NOTE :**

- Burst Length: BL8 fixed by MRS: set MR0 [A1:0=00].
- Output Buffer Enable
  - set MR1 [A12 = 0] : Qoff = Output buffer enabled
  - set MR1 [A2:1 = 00] : Output Driver Impedance Control = RZQ/7
- RTT<sub>Nom</sub> enable
  - set MR1 [A10:8 = 011] : RTT<sub>NOM</sub> = RZQ/6
- RTT<sub>WR</sub> enable
  - set MR2 [A10:9 = 01] : RTT<sub>WR</sub> = RZQ/2
- RTT<sub>PARK</sub> disable
  - set MR5 [A8:6 = 000]
- CAL enabled : set MR4 [A8:6 = 001] : 1600MT/s  
 010] : 1866MT/s, 2133MT/s  
 011] : 2400MT/s
- Gear Down mode enabled :set MR3 [A3 = 1] : 1/4 Rate
- DLL disabled : set MR1 [A0 = 0]
- CA parity enabled :set MR5 [A2:0 = 001] : 1600MT/s,1866MT/s, 2133MT/s  
 010] : 2400MT/s
- Read DBI enabled : set MR5 [A12 = 1]
- Write DBI enabled : set :MR5 [A11 = 1]
- Low Power Array Self Refresh (LP ASR) : set MR2 [A7:6 = 00] : Normal  
 01] : Reduced Temperature range  
 10] : Extended Temperature range  
 11] : Auto Self Refresh
- IDD2NG should be measured after sync pulse(NOP) input.

[ Table 38 ] IDD0, IDD0A and IPP0 Measurement-Loop Pattern<sup>1</sup>

CK_t/CK_c	CKE	Sub-Loop	Cycle Number	Command	CS_n	ACT_n	RAS_n	CAS_n/A15	WE_n/A14	ODT	C[2:0] <sup>3</sup>	BG[1:0] <sup>2</sup>	BA[1:0]	A12/BC_n	A[13,11]	A[10]/AP	A[9:7]	A[6:3]	A[2:0]	Data <sup>4</sup>				
toggling	Static High	0	0	ACT	0	0	0	0	0	0	0	0	0	0	0	0	0	0	0	0	-			
			1,2	D, D	1	0	0	0	0	0	0	0	0	0	0	0	0	0	0	0	0	0	-	
			3,4	D_#, D_#	1	1	1	1	1	1	0	0	3 <sup>2</sup>	3	0	0	0	7	F	0	0	0	-	
			...	repeat pattern 1...4 until nRAS - 1, truncate if necessary																				
			nRAS	PRE	0	1	0	1	0	0	0	0	0	0	0	0	0	0	0	0	0	0	0	-
			...	repeat pattern 1...4 until nRC - 1, truncate if necessary																				
		1	1*nRC	repeat Sub-Loop 0, use BG[1:0] <sup>2</sup> = 1, BA[1:0] = 1 instead																				
		2	2*nRC	repeat Sub-Loop 0, use BG[1:0] <sup>2</sup> = 0, BA[1:0] = 2 instead																				
		3	3*nRC	repeat Sub-Loop 0, use BG[1:0] <sup>2</sup> = 1, BA[1:0] = 3 instead																				
		4	4*nRC	repeat Sub-Loop 0, use BG[1:0] <sup>2</sup> = 0, BA[1:0] = 1 instead																				
		5	5*nRC	repeat Sub-Loop 0, use BG[1:0] <sup>2</sup> = 1, BA[1:0] = 2 instead																				
		6	6*nRC	repeat Sub-Loop 0, use BG[1:0] <sup>2</sup> = 0, BA[1:0] = 3 instead																				
		7	7*nRC	repeat Sub-Loop 0, use BG[1:0] <sup>2</sup> = 1, BA[1:0] = 0 instead																				
		8	8*nRC	repeat Sub-Loop 0, use BG[1:0] <sup>2</sup> = 2, BA[1:0] = 0 instead																				
		9	9*nRC	repeat Sub-Loop 0, use BG[1:0] <sup>2</sup> = 3, BA[1:0] = 1 instead																				
10	10*nRC	repeat Sub-Loop 0, use BG[1:0] <sup>2</sup> = 2, BA[1:0] = 2 instead																						
11	11*nRC	repeat Sub-Loop 0, use BG[1:0] <sup>2</sup> = 3, BA[1:0] = 3 instead																						
12	12*nRC	repeat Sub-Loop 0, use BG[1:0] <sup>2</sup> = 2, BA[1:0] = 1 instead																						
13	13*nRC	repeat Sub-Loop 0, use BG[1:0] <sup>2</sup> = 3, BA[1:0] = 2 instead																						
14	14*nRC	repeat Sub-Loop 0, use BG[1:0] <sup>2</sup> = 2, BA[1:0] = 3 instead																						
15	15*nRC	repeat Sub-Loop 0, use BG[1:0] <sup>2</sup> = 3, BA[1:0] = 0 instead																						

For x4 and x8 only

- NOTE :**  
 1. DQS\_t, DQS\_c are VDDQ.  
 2. BG1 is don't care for x16 device  
 3. C[2:0] are used only for 3DS device  
 4. DQ signals are VDDQ.

[ Table 39 ] IDD1, IDD1A and IPP1 Measurement-Loop Pattern<sup>1</sup>

CK_t, CK_c	CKE	Sub-Loop	Cycle Number	Command	CS_n	ACT_n	RAS_n	CAS_n/A15	WE_n/A14	ODT	C[2:0] <sup>3</sup>	BG[1:0] <sup>2</sup>	BA[1:0]	A12/BC_n	A[13,11]	A[10]/AP	A[9:7]	A[6:3]	A[2:0]	Data <sup>4</sup>			
toggling	Static High	0	0	ACT	0	0	0	0	0	0	0	0	0	0	0	0	0	0	0	0	-		
			1, 2	D, D	1	0	0	0	0	0	0	0	0	0	0	0	0	0	0	0	0	-	
			3, 4	D#, D#	1	1	1	1	1	1	0	0	3 <sup>b</sup>	3	3	0	0	0	7	F	0	-	
			...	repeat pattern 1...4 until nRCD - AL - 1, truncate if necessary																			
			nRCD -AL	RD	0	1	1	0	1	0	0	0	0	0	0	0	0	0	0	0	0	0	D0=00, D1=FF D2=FF, D3=00 D4=FF, D5=00 D6=00, D7=FF
			...	repeat pattern 1...4 until nRAS - 1, truncate if necessary																			
			nRAS	PRE	0	1	0	1	0	0	0	0	0	0	0	0	0	0	0	0	0	0	-
			...	repeat pattern 1...4 until nRC - 1, truncate if necessary																			
			1*nRC + 0	ACT	0	0	0	1	1	0	0	1	1	0	0	0	0	0	0	0	0	0	-
			1*nRC + 1, 2	D, D	1	0	0	0	0	0	0	0	0	0	0	0	0	0	0	0	0	0	-
			1*nRC + 3, 4	D#, D#	1	1	1	1	1	0	0	0	3 <sup>b</sup>	3	3	0	0	0	7	F	0	-	
			...	repeat pattern nRC + 1...4 until 1*nRC + nRAS - 1, truncate if necessary																			
			1*nRC + nRCD - AL	RD	0	1	1	0	1	0	0	0	0	1	1	0	0	0	0	0	0	0	D0=FF, D1=00 D2=00, D3=FF D4=00, D5=FF D6=FF, D7=00
			...	repeat pattern 1...4 until nRAS - 1, truncate if necessary																			
			1*nRC + nRAS	PRE	0	1	0	1	0	0	0	0	0	0	0	0	0	0	0	0	0	0	-
			...	repeat nRC + 1...4 until 2*nRC - 1, truncate if necessary																			
		2	2*nRC	repeat Sub-Loop 0, use BG[1:0] <sup>2</sup> = 0, BA[1:0] = 2 instead																			
		3	3*nRC	repeat Sub-Loop 1, use BG[1:0] <sup>2</sup> = 1, BA[1:0] = 3 instead																			
		4	4*nRC	repeat Sub-Loop 0, use BG[1:0] <sup>2</sup> = 0, BA[1:0] = 1 instead																			
		5	5*nRC	repeat Sub-Loop 1, use BG[1:0] <sup>2</sup> = 1, BA[1:0] = 2 instead																			
		6	6*nRC	repeat Sub-Loop 0, use BG[1:0] <sup>2</sup> = 0, BA[1:0] = 3 instead																			
		8	7*nRC	repeat Sub-Loop 1, use BG[1:0] <sup>2</sup> = 1, BA[1:0] = 0 instead																			
		9	9*nRC	repeat Sub-Loop 1, use BG[1:0] <sup>2</sup> = 2, BA[1:0] = 0 instead																			
		10	10*nRC	repeat Sub-Loop 0, use BG[1:0] <sup>2</sup> = 3, BA[1:0] = 1 instead																			
		11	11*nRC	repeat Sub-Loop 1, use BG[1:0] <sup>2</sup> = 2, BA[1:0] = 2 instead																			
		12	12*nRC	repeat Sub-Loop 0, use BG[1:0] <sup>2</sup> = 3, BA[1:0] = 3 instead																			
13	13*nRC	repeat Sub-Loop 1, use BG[1:0] <sup>2</sup> = 2, BA[1:0] = 1 instead																					
14	14*nRC	repeat Sub-Loop 0, use BG[1:0] <sup>2</sup> = 3, BA[1:0] = 2 instead																					
15	15*nRC	repeat Sub-Loop 1, use BG[1:0] <sup>2</sup> = 2, BA[1:0] = 3 instead																					
16	16*nRC	repeat Sub-Loop 0, use BG[1:0] <sup>2</sup> = 3, BA[1:0] = 0 instead																					

For x4 and x8 only

- NOTE :**
1. DQS\_t, DQS\_c are used according to RD Commands, otherwise VDDQ
  2. BG1 is don't care for x16 device
  3. C[2:0] are used only for 3DS device
  4. Burst Sequence driven on each DQ signal by Read Command. Outside burst operation, DQ signals are VDDQ.

[ Table 40 ] IDD2N, IDD2NA, IDD2NL, IDD2NG, IDD2ND, IDD2N\_par, IPP2,IDD3N, IDD3NA and IDD3P Measurement-Loop Pattern<sup>1</sup>

CK_t, CK_c	CKE	Sub-Loop	Cycle Number	Command	CS_n	ACT_n	RAS_n	CAS_n/A15	WE_n/A14	ODT	C[2:0] <sup>3</sup>	BG[1:0] <sup>2</sup>	BA[1:0]	A12/BC_n	A[13,11]	A[10]/AP	A[9:7]	A[6:3]	A[2:0]	Data <sup>4</sup>			
toggling	Static High	0	0	D, D	1	0	0	0	0	0	0	0	0	0	0	0	0	0	0	0	0		
			1	D, D	1	0	0	0	0	0	0	0	0	0	0	0	0	0	0	0	0	0	
			2	D#, D#	1	1	1	1	1	1	0	0	3 <sup>2</sup>	3	0	0	0	0	7	F	0	0	0
			3	D#, D#	1	1	1	1	1	1	0	0	3 <sup>2</sup>	3	0	0	0	0	7	F	0	0	0
		1	4-7	repeat Sub-Loop 0, use <b>BG[1:0]<sup>2</sup> = 1, BA[1:0] = 1</b> instead																			
		2	8-11	repeat Sub-Loop 0, use <b>BG[1:0]<sup>2</sup> = 0, BA[1:0] = 2</b> instead																			
		3	12-15	repeat Sub-Loop 0, use <b>BG[1:0]<sup>2</sup> = 1, BA[1:0] = 3</b> instead																			
		4	16-19	repeat Sub-Loop 0, use <b>BG[1:0]<sup>2</sup> = 0, BA[1:0] = 1</b> instead																			
		5	20-23	repeat Sub-Loop 0, use <b>BG[1:0]<sup>2</sup> = 1, BA[1:0] = 2</b> instead																			
		6	24-27	repeat Sub-Loop 0, use <b>BG[1:0]<sup>2</sup> = 0, BA[1:0] = 3</b> instead																			
		7	28-31	repeat Sub-Loop 0, use <b>BG[1:0]<sup>2</sup> = 1, BA[1:0] = 0</b> instead																			
		8	32-35	repeat Sub-Loop 0, use <b>BG[1:0]<sup>2</sup> = 2, BA[1:0] = 0</b> instead																			
		9	36-39	repeat Sub-Loop 0, use <b>BG[1:0]<sup>2</sup> = 3, BA[1:0] = 1</b> instead																			
		10	40-43	repeat Sub-Loop 0, use <b>BG[1:0]<sup>2</sup> = 2, BA[1:0] = 2</b> instead																			
		11	44-47	repeat Sub-Loop 0, use <b>BG[1:0]<sup>2</sup> = 3, BA[1:0] = 3</b> instead																			
		12	48-51	repeat Sub-Loop 0, use <b>BG[1:0]<sup>2</sup> = 2, BA[1:0] = 1</b> instead																			
13	52-55	repeat Sub-Loop 0, use <b>BG[1:0]<sup>2</sup> = 3, BA[1:0] = 2</b> instead																					
14	56-59	repeat Sub-Loop 0, use <b>BG[1:0]<sup>2</sup> = 2, BA[1:0] = 3</b> instead																					
15	60-63	repeat Sub-Loop 0, use <b>BG[1:0]<sup>2</sup> = 3, BA[1:0] = 0</b> instead																					

- NOTE :**
1. DQS\_t, DQS\_c are VDDQ.
  2. BG1 is don't care for x16 device
  3. C[2:0] are used only for 3DS device
  4. DQ signals are VDDQ.

[ Table 41 ] IDD2NT and IDDQ2NT Measurement-Loop Pattern<sup>1</sup>

CK_t, CK_c	CKE	Sub-Loop	Cycle Number	Command	CS_n	ACT_n	RAS_n	CAS_n/A15	WE_n/A14	ODT	C[2:0] <sup>3</sup>	BG[1:0] <sup>2</sup>	BA[1:0]	A12/BC_n	A[13,11]	A[10]/AP	A[9:7]	A[6:3]	A[2:0]	Data <sup>4</sup>		
toggling	Static High	0	0	D, D	1	0	0	0	0	0	0	0	0	0	0	0	0	0	0	0	-	
			1	D, D	1	0	0	0	0	0	0	0	0	0	0	0	0	0	0	0	0	-
			2	D#, D#	1	1	1	1	1	1	0	0	3 <sup>2</sup>	3	0	0	0	0	7	F	0	-
			3	D#, D#	1	1	1	1	1	1	0	0	3 <sup>2</sup>	3	0	0	0	0	7	F	0	-
		1	4-7	repeat Sub-Loop 0, but ODT = 1 and BG[1:0] <sup>2</sup> = 1, BA[1:0] = 1 instead																		
		2	8-11	repeat Sub-Loop 0, but ODT = 0 and BG[1:0] <sup>2</sup> = 0, BA[1:0] = 2 instead																		
		3	12-15	repeat Sub-Loop 0, but ODT = 1 and BG[1:0] <sup>2</sup> = 1, BA[1:0] = 3 instead																		
		4	16-19	repeat Sub-Loop 0, but ODT = 0 and BG[1:0] <sup>2</sup> = 0, BA[1:0] = 1 instead																		
		5	20-23	repeat Sub-Loop 0, but ODT = 1 and BG[1:0] <sup>2</sup> = 1, BA[1:0] = 2 instead																		
		6	24-27	repeat Sub-Loop 0, but ODT = 0 and BG[1:0] <sup>2</sup> = 0, BA[1:0] = 3 instead																		
		7	28-31	repeat Sub-Loop 0, but ODT = 1 and BG[1:0] <sup>2</sup> = 1, BA[1:0] = 0 instead																		
		8	32-35	repeat Sub-Loop 0, but ODT = 0 and BG[1:0] <sup>2</sup> = 2, BA[1:0] = 0 instead																		
		9	36-39	repeat Sub-Loop 0, but ODT = 1 and BG[1:0] <sup>2</sup> = 3, BA[1:0] = 1 instead																		
		10	40-43	repeat Sub-Loop 0, but ODT = 0 and BG[1:0] <sup>2</sup> = 2, BA[1:0] = 2 instead																		
		11	44-47	repeat Sub-Loop 0, but ODT = 1 and BG[1:0] <sup>2</sup> = 3, BA[1:0] = 3 instead																		
12	48-51	repeat Sub-Loop 0, but ODT = 0 and BG[1:0] <sup>2</sup> = 2, BA[1:0] = 1 instead																				
13	52-55	repeat Sub-Loop 0, but ODT = 1 and BG[1:0] <sup>2</sup> = 3, BA[1:0] = 2 instead																				
14	56-59	repeat Sub-Loop 0, but ODT = 0 and BG[1:0] <sup>2</sup> = 2, BA[1:0] = 3 instead																				
15	60-63	repeat Sub-Loop 0, but ODT = 1 and BG[1:0] <sup>2</sup> = 3, BA[1:0] = 0 instead																				

- NOTE :**  
 1. DQS\_t, DQS\_c are VDDQ.  
 2. BG1 is don't care for x16 device  
 3. C[2:0] are used only for 3DS device  
 4. DQ signals are VDDQ.

For x4 and x8 only

[ Table 42 ] IDD4R, IDDR4RA, IDD4RB and IDDQ4R Measurement-Loop Pattern<sup>1</sup>

CK_t, CK_c	CKE	Sub-Loop	Cycle Number	Command	CS_n	ACT_n	RAS_n	CAS_n/A15	WE_n/A14	ODT	C[2:0] <sup>3</sup>	BG[1:0] <sup>2</sup>	BA[1:0]	A12/BC_n	A[13,11]	A[10]/AP	A[9:7]	A[6:3]	A[2:0]	Data <sup>4</sup>		
toggling	Static High	0	0	RD	0	1	1	0	1	0	0	0	0	0	0	0	0	0	0	0	D0=00, D1=FF D2=FF, D3=00 D4=FF, D5=00 D6=00, D7=FF	
			1	D	1	0	0	0	0	0	0	0	0	0	0	0	0	0	0	0	0	-
			2,3	D#, D#	1	1	1	1	1	1	0	0	0	3 <sup>2</sup>	3	0	0	0	7	F	0	-
		1	4	RD	0	1	1	0	1	0	0	0	0	1	1	0	0	0	7	F	0	D0=FF, D1=00 D2=00, D3=FF D4=00, D5=FF D6=FF, D7=00
			5	D	1	0	0	0	0	0	0	0	0	0	0	0	0	0	0	0	0	-
			6,7	D#, D#	1	1	1	1	1	1	0	0	0	3 <sup>2</sup>	3	0	0	0	7	F	0	-
		2	8-11	repeat Sub-Loop 0, use BG[1:0] <sup>2</sup> = 0, BA[1:0] = 2 instead																		
		3	12-15	repeat Sub-Loop 1, use BG[1:0] <sup>2</sup> = 1, BA[1:0] = 3 instead																		
		4	16-19	repeat Sub-Loop 0, use BG[1:0] <sup>2</sup> = 0, BA[1:0] = 1 instead																		
		5	20-23	repeat Sub-Loop 1, use BG[1:0] <sup>2</sup> = 1, BA[1:0] = 2 instead																		
		6	24-27	repeat Sub-Loop 0, use BG[1:0] <sup>2</sup> = 0, BA[1:0] = 3 instead																		
		7	28-31	repeat Sub-Loop 1, use BG[1:0] <sup>2</sup> = 1, BA[1:0] = 0 instead																		
		8	32-35	repeat Sub-Loop 0, use BG[1:0] <sup>2</sup> = 2, BA[1:0] = 0 instead																		
		9	36-39	repeat Sub-Loop 1, use BG[1:0] <sup>2</sup> = 3, BA[1:0] = 1 instead																		
		10	40-43	repeat Sub-Loop 0, use BG[1:0] <sup>2</sup> = 2, BA[1:0] = 2 instead																		
11	44-47	repeat Sub-Loop 1, use BG[1:0] <sup>2</sup> = 3, BA[1:0] = 3 instead																				
12	48-51	repeat Sub-Loop 0, use BG[1:0] <sup>2</sup> = 2, BA[1:0] = 1 instead																				
13	52-55	repeat Sub-Loop 1, use BG[1:0] <sup>2</sup> = 3, BA[1:0] = 2 instead																				
14	56-59	repeat Sub-Loop 0, use BG[1:0] <sup>2</sup> = 2, BA[1:0] = 3 instead																				
15	60-63	repeat Sub-Loop 1, use BG[1:0] <sup>2</sup> = 3, BA[1:0] = 0 instead																				
																				For x4 and x8 only		

- NOTE :**
1. DQS\_t, DQS\_c are used according to RD Commands, otherwise VDDQ.
  2. BG1 is don't care for x16 device
  3. C[2:0] are used only for 3DS device
  4. Burst Sequence driven on each DQ signal by Read Command.

[ Table 43 ] IDD4W, IDD4WA, IDD4WB and IDD4W\_par Measurement-Loop Pattern<sup>1</sup>

CK_t, CK_c	CKE	Sub-Loop	Cycle Number	Command	CS_n	ACT_n	RAS_n	CAS_n/A15	WE_n/A14	ODT	C[2:0] <sup>3</sup>	BG[1:0] <sup>2</sup>	BA[1:0]	A12/BC_n	A[13,11]	A[10]/AP	A[9:7]	A[6:3]	A[2:0]	Data <sup>4</sup>		
toggling	Static High	0	0	WR	0	1	1	0	1	1	0	0	0	0	0	0	0	0	0	0	D0=00, D1=FF D2=FF, D3=00 D4=FF, D5=00 D6=00, D7=FF	
			1	D	1	0	0	0	0	1	0	0	0	0	0	0	0	0	0	0	-	
			2,3	D#, D#	1	1	1	1	1	1	1	0	3 <sup>2</sup>	3	0	0	0	7	F	0	-	
		1	4	WR	0	1	1	0	1	1	1	0	1	1	0	0	0	7	F	0	0	D0=FF, D1=00 D2=00, D3=FF D4=00, D5=FF D6=FF, D7=00
			5	D	1	0	0	0	0	1	0	0	0	0	0	0	0	0	0	0	0	-
			6,7	D#, D#	1	1	1	1	1	1	1	0	3 <sup>2</sup>	3	0	0	0	7	F	0	-	
		2	8-11	repeat Sub-Loop 0, use <b>BG[1:0]<sup>2</sup> = 0, BA[1:0] = 2</b> instead																		
		3	12-15	repeat Sub-Loop 1, use <b>BG[1:0]<sup>2</sup> = 1, BA[1:0] = 3</b> instead																		
		4	16-19	repeat Sub-Loop 0, use <b>BG[1:0]<sup>2</sup> = 0, BA[1:0] = 1</b> instead																		
		5	20-23	repeat Sub-Loop 1, use <b>BG[1:0]<sup>2</sup> = 1, BA[1:0] = 2</b> instead																		
		6	24-27	repeat Sub-Loop 0, use <b>BG[1:0]<sup>2</sup> = 0, BA[1:0] = 3</b> instead																		
		7	28-31	repeat Sub-Loop 1, use <b>BG[1:0]<sup>2</sup> = 1, BA[1:0] = 0</b> instead																		
		8	32-35	repeat Sub-Loop 0, use <b>BG[1:0]<sup>2</sup> = 2, BA[1:0] = 0</b> instead																		
		9	36-39	repeat Sub-Loop 1, use <b>BG[1:0]<sup>2</sup> = 3, BA[1:0] = 1</b> instead																		
		10	40-43	repeat Sub-Loop 0, use <b>BG[1:0]<sup>2</sup> = 2, BA[1:0] = 2</b> instead																		
11	44-47	repeat Sub-Loop 1, use <b>BG[1:0]<sup>2</sup> = 3, BA[1:0] = 3</b> instead																				
12	48-51	repeat Sub-Loop 0, use <b>BG[1:0]<sup>2</sup> = 2, BA[1:0] = 1</b> instead																				
13	52-55	repeat Sub-Loop 1, use <b>BG[1:0]<sup>2</sup> = 3, BA[1:0] = 2</b> instead																				
14	56-59	repeat Sub-Loop 0, use <b>BG[1:0]<sup>2</sup> = 2, BA[1:0] = 3</b> instead																				
15	60-63	repeat Sub-Loop 1, use <b>BG[1:0]<sup>2</sup> = 3, BA[1:0] = 0</b> instead																				

- NOTE :**
1. DQS\_t, DQS\_c are used according to WR Commands, otherwise VDDQ.
  2. BG1 is don't care for x16 device
  3. C[2:0] are used only for 3DS device
  4. Burst Sequence driven on each DQ signal by Write Command.

For x4 and x8 only

[ Table 44 ] IDD4WC Measurement-Loop Pattern<sup>1</sup>

CK_t, CK_c	CKE	Sub-Loop	Cycle Number	Command	CS_n	ACT_n	RAS_n	CAS_n/A15	WE_n/A14	ODT	C[2:0] <sup>3</sup>	BG[1:0] <sup>2</sup>	BA[1:0]	A12/BC_n	A[13,11]	A[10]/AP	A[9:7]	A[6:3]	A[2:0]	Data <sup>4</sup>		
toggling	Static High	0	0	WR	0	1	1	0	1	1	0	0	0	0	0	0	0	0	0	0	D0=00, D1=FF D2=FF, D3=00 D4=FF, D5=00 D6=00, D7=FF D8=CRC	
			1,2	D, D	1	0	0	0	0	1	0	0	0	0	0	0	0	0	0	0	-	
			3,4	D#, D#	1	1	1	1	1	1	1	0	3 <sup>2</sup>	3	0	0	0	0	7	F	0	-
			5	WR	0	1	1	0	1	1	1	0	1	1	0	0	0	0	7	F	0	D0=FF, D1=00 D2=00, D3=FF D4=00, D5=FF D6=FF, D7=00 D8=CRC
			6,7	D, D	1	0	0	0	0	1	0	0	0	0	0	0	0	0	0	0	0	-
			8,9	D#, D#	1	1	1	1	1	1	1	0	3 <sup>2</sup>	3	0	0	0	0	7	F	0	-
		2	10-14	repeat Sub-Loop 0, use <b>BG[1:0]<sup>2</sup> = 0, BA[1:0] = 2</b> instead																		
		3	15-19	repeat Sub-Loop 1, use <b>BG[1:0]<sup>2</sup> = 1, BA[1:0] = 3</b> instead																		
		4	20-24	repeat Sub-Loop 0, use <b>BG[1:0]<sup>2</sup> = 0, BA[1:0] = 1</b> instead																		
		5	25-29	repeat Sub-Loop 1, use <b>BG[1:0]<sup>2</sup> = 1, BA[1:0] = 2</b> instead																		
		6	30-34	repeat Sub-Loop 0, use <b>BG[1:0]<sup>2</sup> = 0, BA[1:0] = 3</b> instead																		
		7	35-39	repeat Sub-Loop 1, use <b>BG[1:0]<sup>2</sup> = 1, BA[1:0] = 0</b> instead																		
		8	40-44	repeat Sub-Loop 0, use <b>BG[1:0]<sup>2</sup> = 2, BA[1:0] = 0</b> instead																		
		9	45-49	repeat Sub-Loop 1, use <b>BG[1:0]<sup>2</sup> = 3, BA[1:0] = 1</b> instead																		
		10	50-54	repeat Sub-Loop 0, use <b>BG[1:0]<sup>2</sup> = 2, BA[1:0] = 2</b> instead																		
11	55-59	repeat Sub-Loop 1, use <b>BG[1:0]<sup>2</sup> = 3, BA[1:0] = 3</b> instead																				
12	60-64	repeat Sub-Loop 0, use <b>BG[1:0]<sup>2</sup> = 2, BA[1:0] = 1</b> instead																				
13	65-69	repeat Sub-Loop 1, use <b>BG[1:0]<sup>2</sup> = 3, BA[1:0] = 2</b> instead																				
14	70-74	repeat Sub-Loop 0, use <b>BG[1:0]<sup>2</sup> = 2, BA[1:0] = 3</b> instead																				
15	75-79	repeat Sub-Loop 1, use <b>BG[1:0]<sup>2</sup> = 3, BA[1:0] = 0</b> instead																				

- NOTE :**
1. DQS\_t, DQS\_c are VDDQ.
  2. BG1 is don't care for x16 device.
  3. C[2:0] are used only for 3DS device.
  4. Burst Sequence driven on each DQ signal by Write Command.

For x4 and x8 only

[ Table 45 ] IDD5B Measurement-Loop Pattern<sup>1</sup>

CK_t, CK_c	CKE	Sub-Loop	Cycle Number	Command	CS_n	ACT_n	RAS_n	CAS_n/A15	WE_n/A14	ODT	C[2:0] <sup>3</sup>	BG[1:0] <sup>2</sup>	BA[1:0]	A12/BC_n	A[13,11]	A[10]/AP	A[9:7]	A[6:3]	A[2:0]	Data <sup>4</sup>			
toggling	Static High	0	0	REF	1	0	0	0	0	0	0	0	0	0	0	0	0	0	0	0	-		
		1	1	D	1	0	0	0	0	0	0	0	0	0	0	0	0	0	0	0	0	-	
		2	2	D	1	0	0	0	0	0	0	0	0	0	0	0	0	0	0	0	0	0	-
		3	3	D#, D#	1	1	1	1	1	1	0	0	3 <sup>2</sup>	3	0	0	0	7	F	0	0	0	-
		4	4	D#, D#	1	1	1	1	1	1	0	0	3 <sup>2</sup>	3	0	0	0	7	F	0	0	0	-
		4-7	repeat pattern 1...4, use BG[1:0] <sup>2</sup> = 1, BA[1:0] = 1 instead																				
		8-11	repeat pattern 1...4, use BG[1:0] <sup>2</sup> = 0, BA[1:0] = 2 instead																				
		12-15	repeat pattern 1...4, use BG[1:0] <sup>2</sup> = 1, BA[1:0] = 3 instead																				
		16-19	repeat pattern 1...4, use BG[1:0] <sup>2</sup> = 0, BA[1:0] = 1 instead																				
		20-23	repeat pattern 1...4, use BG[1:0] <sup>2</sup> = 1, BA[1:0] = 2 instead																				
		24-27	repeat pattern 1...4, use BG[1:0] <sup>2</sup> = 0, BA[1:0] = 3 instead																				
		28-31	repeat pattern 1...4, use BG[1:0] <sup>2</sup> = 1, BA[1:0] = 0 instead																				
		32-35	repeat pattern 1...4, use BG[1:0] <sup>2</sup> = 2, BA[1:0] = 0 instead																				
		36-39	repeat pattern 1...4, use BG[1:0] <sup>2</sup> = 3, BA[1:0] = 1 instead																				
		40-43	repeat pattern 1...4, use BG[1:0] <sup>2</sup> = 2, BA[1:0] = 2 instead																				
		44-47	repeat pattern 1...4, use BG[1:0] <sup>2</sup> = 3, BA[1:0] = 3 instead																				
		48-51	repeat pattern 1...4, use BG[1:0] <sup>2</sup> = 2, BA[1:0] = 1 instead																				
		52-55	repeat pattern 1...4, use BG[1:0] <sup>2</sup> = 3, BA[1:0] = 2 instead																				
		56-59	repeat pattern 1...4, use BG[1:0] <sup>2</sup> = 2, BA[1:0] = 3 instead																				
		60-63	repeat pattern 1...4, use BG[1:0] <sup>2</sup> = 3, BA[1:0] = 0 instead																				
		2	64 ... nRFC - 1	repeat Sub-Loop 1, Truncate, if necessary																			

For x4 and x8 only

- NOTE :**  
 1. DQS\_t, DQS\_c are VDDQ.  
 2. BG1 is don't care for x16 device.  
 3. C[2:0] are used only for 3DS device.  
 4. DQ signals are VDDQ.

[ Table 46 ] IDD7 Measurement-Loop Pattern<sup>1</sup>

CK_t, CK_c	CKE	Sub-Loop	Cycle Number	Command	CS_n	ACT_n	RAS_n	CAS_n/A15	WE_n/A14	ODT	C[2:0] <sup>3</sup>	BG[1:0] <sup>2</sup>	BA[1:0]	A12/BC_n	A[13,11]	A[10]/AP	A[9:7]	A[6:3]	A[2:0]	Data <sup>4</sup>			
toggling	Static High	0	0	ACT	0	0	0	0	0	0	0	0	0	0	0	0	0	0	0	0	-		
			1	RDA	0	1	1	0	1	0			0	0	0	0	1	0	0	0	0	D0=00, D1=FF D2=FF, D3=00 D4=FF, D5=00 D6=00, D7=FF	
			2	D	1	0	0	0	0	0	0	0	0	0	0	0	0	0	0	0	0	-	
			3	D#	1	1	1	1	1	1	0	0	0	3 <sup>2</sup>	3	0	0	0	7	F	0	-	
		...	repeat pattern 2...3 until nRRD - 1, if nRRD > 4. Truncate if necessary																				
		1	nRRD	ACT	0	0	0	0	0	0	0	0	0	1	1	0	0	0	0	0	0	0	-
			nRRD + 1	RDA	0	1	1	0	1	0			1	1	0	0	1	0	0	0	0	0	D0=FF, D1=00 D2=00, D3=FF D4=00, D5=FF D6=FF, D7=00
		...	repeat pattern 2 ... 3 until 2*nRRD - 1, if nRRD > 4. Truncate if necessary																				
		2	2*nRRD	repeat Sub-Loop 0, use <b>BG[1:0]<sup>2</sup> = 0, BA[1:0] = 2</b> instead																			
		3	3*nRRD	repeat Sub-Loop 1, use <b>BG[1:0]<sup>2</sup> = 1, BA[1:0] = 3</b> instead																			
		4	4*nRRD	repeat pattern 2 ... 3 until nFAW - 1, if nFAW > 4*nRRD. Truncate if necessary																			
		5	nFAW	repeat Sub-Loop 0, use <b>BG[1:0]<sup>2</sup> = 0, BA[1:0] = 1</b> instead																			
		6	nFAW + nRRD	repeat Sub-Loop 1, use <b>BG[1:0]<sup>2</sup> = 1, BA[1:0] = 2</b> instead																			
		7	nFAW + 2*nRRD	repeat Sub-Loop 0, use <b>BG[1:0]<sup>2</sup> = 0, BA[1:0] = 3</b> instead																			
		8	nFAW + 3*nRRD	repeat Sub-Loop 1, use <b>BG[1:0]<sup>2</sup> = 1, BA[1:0] = 0</b> instead																			
		9	nFAW + 4*nRRD	repeat Sub-Loop 4																			
		10	2*nFAW	repeat Sub-Loop 0, use <b>BG[1:0]<sup>2</sup> = 2, BA[1:0] = 0</b> instead																			
		11	2*nFAW + nRRD	repeat Sub-Loop 1, use <b>BG[1:0]<sup>2</sup> = 3, BA[1:0] = 1</b> instead																			
		12	2*nFAW + 2*nRRD	repeat Sub-Loop 0, use <b>BG[1:0]<sup>2</sup> = 2, BA[1:0] = 2</b> instead																			
		13	2*nFAW + 3*nRRD	repeat Sub-Loop 1, use <b>BG[1:0]<sup>2</sup> = 3, BA[1:0] = 3</b> instead																			
14	2*nFAW + 4*nRRD	repeat Sub-Loop 4																					
15	3*nFAW	repeat Sub-Loop 0, use <b>BG[1:0]<sup>2</sup> = 2, BA[1:0] = 1</b> instead																					
16	3*nFAW + nRRD	repeat Sub-Loop 1, use <b>BG[1:0]<sup>2</sup> = 3, BA[1:0] = 2</b> instead																					
17	3*nFAW + 2*nRRD	repeat Sub-Loop 0, use <b>BG[1:0]<sup>2</sup> = 2, BA[1:0] = 3</b> instead																					
18	3*nFAW + 3*nRRD	repeat Sub-Loop 1, use <b>BG[1:0]<sup>2</sup> = 3, BA[1:0] = 0</b> instead																					
19	3*nFAW + 4*nRRD	repeat Sub-Loop 4																					
20	4*nFAW	repeat pattern 2 ... 3 until nRC - 1, if nRC > 4*nFAW. Truncate if necessary																					

For x4 and x8 only

- NOTE :**  
 1. DQS\_t, DQS\_c are VDDQ.  
 2. BG1 is don't care for x16 device.  
 3. C[2:0] are used only for 3DS device.  
 4. Burst Sequence driven on each DQ signal by Read Command. Outside burst operation, DQ signals are VDDQ.

## 12.8Gb DDR4 SDRAM B-die IDD Specification Table

IDD and IPP values are for typical operating range of voltage and temperature unless otherwise noted.

[ Table 47 ]  $I_{DD}$  and  $I_{DDQ}$  Specification

Symbol	512Mx16 (K4A8G165WB)			Unit	NOTE
	DDR4-2133	DDR4-2400	DDR4-2666		
	15-15-15	17-17-17	19-19-19		
	VDD 1.2V				
	IDD Max.	IDD Max.	IDD Max.		
$I_{DD0}$	41.9	42.6	TBD	mA	
$I_{DD0A}$	43.6	45.5	TBD	mA	
$I_{DD1}$	67	71.2	TBD	mA	
$I_{DD1A}$	69.4	74	TBD	mA	
$I_{DD2N}$	22	23	TBD	mA	
$I_{DD2NA}$	25	26	TBD	mA	
$I_{DD2NT}$	25	26	TBD	mA	
$I_{DD2NL}$	16	17	TBD	mA	
$I_{DD2NG}$	22	20.3	TBD	mA	
$I_{DD2ND}$	20	18	TBD	mA	
$I_{DD2N\_par}$	23	24	TBD	mA	
$I_{DD2P}$	16	16	TBD	mA	
$I_{DD2Q}$	20	21	TBD	mA	
$I_{DD3N}$	36	36	TBD	mA	
$I_{DD3NA}$	38	38	TBD	mA	
$I_{DD3P}$	21	22	TBD	mA	
$I_{DD4R}$	162.7	190.4	TBD	mA	
$I_{DD4RA}$	166.2	177.4	TBD	mA	
$I_{DD4RB}$	161	173	TBD	mA	
$I_{DD4W}$	120.6	131.7	TBD	mA	
$I_{DD4WA}$	124.6	135.7	TBD	mA	
$I_{DD4WB}$	120.9	132.1	TBD	mA	
$I_{DD4WC}$	110.3	120.5	TBD	mA	
$I_{DD4W\_par}$	128.1	144.9	TBD	mA	
$I_{DD5B}$	219.5	216.4	TBD	mA	
$I_{DD5F2}$	154.7	151.7	TBD	mA	
$I_{DD5F4}$	128.5	128.4	TBD	mA	
$I_{DD6N}$	23	23	TBD	mA	
$I_{DD6E}$	34	34	TBD	mA	
$I_{DD6R}$	16	16	TBD	mA	
$I_{DD6A}$	22	22	TBD	mA	
$I_{DD7}$	212.2	224	TBD	mA	
$I_{DD8}$	11	11	TBD	mA	

[ Table 48 ]  $I_{PP}$  Specification

Symbol	512Mx16 (K4A8G165WB)			Unit	NOTE
	DDR4-2133	DDR4-2400	DDR4-2666		
	15-15-15	17-17-17	19-19-19		
	VPP 2.5V				
IPP Max.	IPP Max.	IPP Max.			
$I_{PP0}$	4	4	TBD	mA	
$I_{PP1}$	4	4	TBD	mA	
$I_{PP2N}$	3	3	TBD	mA	
$I_{PP2P}$	3	3	TBD	mA	
$I_{PP3N}$	3	3	TBD	mA	
$I_{PP3P}$	3	3	TBD	mA	
$I_{PP4R}$	3	3	TBD	mA	
$I_{PP4W}$	3	3	TBD	mA	
$I_{PP5B}$	18	18	TBD	mA	
$I_{PP5F2}$	15	15	TBD	mA	
$I_{PP5F4}$	14	14	TBD	mA	
$I_{PP6N}$	4	4	TBD	mA	
$I_{PP6E}$	5	5	TBD	mA	
$I_{PP6R}$	3.5	3.5	TBD	mA	
$I_{PP6A}$	4	4	TBD	mA	
$I_{PP7}$	8	8.5	TBD	mA	
$I_{PP8}$	3	3	TBD	mA	

[ Table 49 ]  $I_{DD6}$  Specification

Symbol	Temperature Range	Value			Unit	NOTE
		512Mx16 (K4A8G165WB)				
		DDR4-2133	DDR4-2400	DDR4-2666		
		15-15-15	17-17-17	19-19-19		
VDD 1.2V						
$I_{DD6N}$	0 - 85 °C	23	23	TBD	mA	3,4
$I_{DD6E}$	0 - 95 °C	34	34	TBD	mA	4,5

**NOTE :**

1. Some  $I_{DD}$  currents are higher for x16 organization due to larger page-size architecture.
2. Max. values for  $I_{DD}$  currents considering worst case conditions of process, temperature and voltage.
3. Applicable for MR2 settings A6=0 and A7=0.
4. Supplier data sheets include a max value for  $I_{DD6}$ .
5. Applicable for MR2 settings A6=0 and A7=1.  $I_{DD6ET}$  is only specified for devices which support the Extended Temperature Range feature.

## 13. Input/Output Capacitance

[ Table 50 ] Silicon pad I/O Capacitance

Symbol	Parameter	DDR4-1600/1866/2133		DDR4-2400/2666		Unit	NOTE
		min	max	min	max		
C <sub>IO</sub>	Input/output capacitance	0.55	1.4	0.55	1.15	pF	1,2,3
C <sub>DIO</sub>	Input/output capacitance delta	-0.1	0.1	-0.1	0.1	pF	1,2,3,11
C <sub>DDQS</sub>	Input/output capacitance delta DQS <sub>t</sub> and DQS <sub>c</sub>	-	0.05	-	0.05	pF	1,2,3,5
C <sub>CK</sub>	Input capacitance, CK <sub>t</sub> and CK <sub>c</sub>	0.2	0.8	0.2	0.7	pF	1,3
C <sub>DCK</sub>	Input capacitance delta CK <sub>t</sub> and CK <sub>c</sub>	-	0.05	-	0.05	pF	1,3,4
C <sub>I</sub>	Input capacitance(CTRL, ADD, CMD pins only)	0.2	0.8	0.2	0.7	pF	1,3,6
C <sub>DI_CTRL</sub>	Input capacitance delta(All CTRL pins only)	-0.1	0.1	-0.1	0.1	pF	1,3,7,8
C <sub>DI_ADD_CMD</sub>	Input capacitance delta(All ADD/CMD pins only)	-0.1	0.1	-0.1	0.1	pF	1,2,9,10
C <sub>ALERT</sub>	Input/output capacitance of ALERT	0.5	1.5	0.5	1.5	pF	1,3
C <sub>ZQ</sub>	Input/output capacitance of ZQ	0.5	2.3	0.5	2.3	pF	1,3,12
C <sub>TEN</sub>	Input capacitance of TEN	0.2	2.3	0.2	2.3	pF	1,3,13

**NOTE:**

- This parameter is not subject to production test. It is verified by design and characterization. The silicon only capacitance is validated by de-embedding the package L & C parasitic. The capacitance is measured with VDD, VDDQ, VSS, VSSQ applied with all other signal pins floating. Measurement procedure tbd.
- DQ, DM<sub>n</sub>, DQS<sub>T</sub>, DQS<sub>C</sub>, TDQS<sub>T</sub>, TDQS<sub>C</sub>. Although the DM, TDQS<sub>T</sub> and TDQS<sub>C</sub> pins have different functions, the loading matches DQ and DQS
- This parameter applies to monolithic devices only; stacked/dual-die devices are not covered here
- Absolute value CK<sub>T</sub>-CK<sub>C</sub>
- Absolute value of C<sub>IO</sub>(DQS<sub>T</sub>)-C<sub>IO</sub>(DQS<sub>C</sub>)
- C<sub>I</sub> applies to ODT, CS<sub>n</sub>, CKE, A0-A15, BA0-BA1, BG0-BG1, RAS<sub>n</sub>, CAS<sub>n</sub>/A15, WE<sub>n</sub>/A14, ACT<sub>n</sub> and PAR.
- C<sub>DI\_CTRL</sub> applies to ODT, CS<sub>n</sub> and CKE
- $C_{DI\_CTRL} = C_I(CTRL) - 0.5 * (C_I(CLK\_T) + C_I(CLK\_C))$
- C<sub>DI\_ADD\_CMD</sub> applies to, A0-A15, BA0-BA1, BG0-BG1, RAS<sub>n</sub>, CAS<sub>n</sub>/A15, WE<sub>n</sub>/A14, ACT<sub>n</sub> and PAR.
- $C_{DI\_ADD\_CMD} = C_I(ADD\_CMD) - 0.5 * (C_I(CLK\_T) + C_I(CLK\_C))$
- $C_{DIO} = C_{IO}(DQ, DM) - 0.5 * (C_{IO}(DQS\_T) + C_{IO}(DQS\_C))$
- Maximum external load capacitance on ZQ pin: tbd pF.
- TEN pin may be DRAM internally pulled low through a weak pull-down resistor to VSS. In this case C<sub>TEN</sub> might not be valid and system shall verify TEN signal with Vendor specific information.

[ Table 51 ] DRAM package electrical specifications(X16)

Symbol	Parameter	DDR4-1600/1866/2133/2400/2666		Unit	NOTE
		min	max		
Z <sub>IO</sub>	Input/output Zpkg	45	85	Ω	1
T <sub>dIO</sub>	Input/output Pkg Delay	14	45	ps	1
L <sub>io</sub>	Input/Output Lpkg	-	3.4	nH	1, 2
C <sub>io</sub>	Input/Output Cpkg	-	0.82	pF	1, 3
Z <sub>IO DQS</sub>	DQS_t, DQS_c Zpkg	45	85	Ω	1
T <sub>dIO DQS</sub>	DQS_t, DQS_c Pkg Delay	14	45	ps	1
L <sub>io DQS</sub>	DQS Lpkg	-	3.4	nH	1, 2
C <sub>io DQS</sub>	DQS Cpkg	-	0.82	pF	1, 3
DZ <sub>DIO DQS</sub>	Delta Zpkg DQSU_t, DQSU_c	-	10	Ω	-
	Delta Zpkg DQSL_t, DQSL_c	-	10	Ω	-
D <sub>TdDIO DQS</sub>	Delta Delay DQSU_t, DQSU_c	-	5	ps	-
	Delta Delay DQSL_t, DQSL_c	-	5	ps	-
Z <sub>i CTRL</sub>	Input CTRL pins Zpkg	50	90	Ω	1
T <sub>dI_CTRL</sub>	Input CTRL pins Pkg Delay	14	42	ps	1
L <sub>i CTRL</sub>	Input CTRL Lpkg	-	3.4	nH	1, 2
C <sub>i CTRL</sub>	Input CTRL Cpkg	-	0.7	pF	1, 3
Z <sub>IADD CMD</sub>	Input- CMD ADD pins Zpkg	50	90	Ω	1
T <sub>dIADD_CMD</sub>	Input- CMD ADD pins Pkg Delay	14	52	ps	1
L <sub>i ADD CMD</sub>	Input CMD ADD Lpkg	-	3.9	nH	1, 2
C <sub>i ADD CMD</sub>	Input CMD ADD Cpkg	-	0.86	pF	1, 3
Z <sub>CK</sub>	CLK_c Zpkg	50	90	Ω	1
T <sub>dCK</sub>	CLK_c Pkg Delay	14	42	ps	1
L <sub>i CLK</sub>	Input CLK Lpkg	-	3.4	nH	1, 2
C <sub>i CLK</sub>	Input CLK Cpkg	-	0.7	pF	1, 3
DZ <sub>DCK</sub>	Delta Zpkg CLK_c	-	10	Ω	-
D <sub>TdCK</sub>	Delta Delay CLK_c	-	5	ps	-
Z <sub>OZQ</sub>	ZQ Zpkg	36	100	Ω	-
T <sub>dO ZQ</sub>	ZQ Delay	20	90	ps	-
Z <sub>O ALERT</sub>	ALERT Zpkg	40	100	Ω	-
T <sub>dO ALERT</sub>	ALERT Delay	20	55	ps	-

**NOTE :**

- Package implementations shall meet spec if the Zpkg and Pkg Delay fall within the ranges shown, and the maximum Lpkg and Cpkg do not exceed the maximum value shown
- It is assumed that Lpkg can be approximated as  $Lpkg = Zo \cdot Td$
- It is assumed that Cpkg can be approximated as  $Cpkg = Td/Zo$

# 14. Electrical Characteristics & AC Timing

## 14.1 Reference Load for AC Timing and Output Slew Rate

Figure 23 represents the effective reference load of 50 ohms used in defining the relevant AC timing parameters of the device as well as output slew rate measurements.

It is not intended as a precise representation of any particular system environment or a depiction of the actual load presented by a production tester. System designers should use IBIS or other simulation tools to correlate the timing reference load to a system environment. Manufacturers correlate to their production test conditions, generally one or more coaxial transmission lines terminated at the tester electronics.

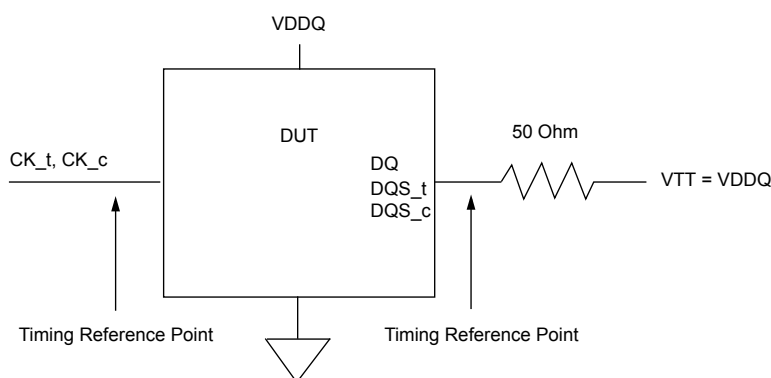

Figure 23. Reference Load for AC Timing and Output Slew Rate

## 14.2 tREFI

Average periodic Refresh interval (tREFI) of DDR4 SDRAM is defined as shown in the table.

[ Table 52 ] tREFI by device density

Parameter	Symbol	2Gb	4Gb	8Gb	16Gb	Units	NOTE	
All Bank Refresh to active/refresh cmd time	tRFC	160	260	350	TBD	ns		
Average periodic refresh interval	tREFI	0 °C ≤ T <sub>CASE</sub> ≤ 85°C	7.8	7.8	7.8	TBD	μs	
		-40 °C ≤ T <sub>CASE</sub> ≤ 85°C	7.8	7.8	7.8	TBD	μs	2
		85 °C < T <sub>CASE</sub> ≤ 95°C	3.9	3.9	3.9	TBD	μs	1

**NOTE :**

- Users should refer to the DRAM supplier data sheet and/or the DIMM SPD to determine if DDR4 SDRAM devices support the following options or requirements referred to in this material.
- Supported only for Industrial Temperature

### 14.3 Timing Parameters by Speed Grade

[ Table 53 ] Timing Parameters by Speed Bin for DDR4-1600 to DDR4-2666

Speed		DDR4-1600		DDR4-1866		DDR4-2133		DDR4-2400		DDR4-2666		Units	NOTE
Parameter	Symbol	MIN	MAX	MIN	MAX	MIN	MAX	MIN	MAX	MIN	MAX		
<b>Clock Timing</b>													
Minimum Clock Cycle Time (DLL off mode)	t <sub>CK</sub> (DLL_OFF)	8	20	8	20	8	20	8	20	8	20	ns	-
Average Clock Period	t <sub>CK</sub> (avg)	1.25	<1.5	1.071	<1.25	0.938	<1.071	0.833	<0.938	0.750	<0.833	ns	35,36
Average high pulse width	t <sub>CH</sub> (avg)	0.48	0.52	0.48	0.52	0.48	0.52	0.48	0.52	0.48	0.52	t <sub>CK</sub> (avg)	
Average low pulse width	t <sub>CL</sub> (avg)	0.48	0.52	0.48	0.52	0.48	0.52	0.48	0.52	0.48	0.52	t <sub>CK</sub> (avg)	
Absolute Clock Period	t <sub>CK</sub> (abs)	t <sub>CK</sub> (avg)min + t <sub>JIT</sub> (per)min_tot t <sub>CK</sub> (avg)max + t <sub>JIT</sub> (per)max_tot										t <sub>CK</sub> (avg)	
Absolute clock HIGH pulse width	t <sub>CH</sub> (abs)	0.45	-	0.45	-	0.45	-	0.45	-	0.45	-	t <sub>CK</sub> (avg)	23
Absolute clock LOW pulse width	t <sub>CL</sub> (abs)	0.45	-	0.45	-	0.45	-	0.45	-	0.45	-	t <sub>CK</sub> (avg)	24
Clock Period Jitter- total	t <sub>JIT</sub> (per)_tot	-63	63	-54	54	-47	47	-42	42	-38	38	ps	23
Clock Period Jitter- deterministic	t <sub>JIT</sub> (per)_dj	-31	31	-27	27	-23	23	-21	21	-19	19	ps	26
Clock Period Jitter during DLL locking period	t <sub>JIT</sub> (per, lck)	-50	50	-43	43	-38	38	-33	33	-30	30	ps	
Cycle to Cycle Period Jitter	t <sub>JIT</sub> (cc)_total	-	125	-	107	-	94	-	83	-	75	ps	25
Cycle to Cycle Period Jitter deterministic	t <sub>JIT</sub> (cc)_dj	-	63	-	54	-	47	-	42	-	38	ps	26
Cycle to Cycle Period Jitter during DLL locking period	t <sub>JIT</sub> (cc, lck)	-	100	-	86	-	75	-	67	-	60	ps	
Duty Cycle Jitter	t <sub>JIT</sub> (duty)	TBD	TBD	TBD	TBD	TBD	TBD	TBD	TBD	TBD	TBD	ps	
Cumulative error across 2 cycles	t <sub>ERR</sub> (2per)	-92	92	-79	79	-69	69	-61	61	-55	55	ps	
Cumulative error across 3 cycles	t <sub>ERR</sub> (3per)	-109	109	-94	94	-82	82	-73	73	-66	66	ps	
Cumulative error across 4 cycles	t <sub>ERR</sub> (4per)	-121	121	-104	104	-91	91	-81	81	-73	73	ps	
Cumulative error across 5 cycles	t <sub>ERR</sub> (5per)	-131	131	-112	112	-98	98	-87	87	-78	78	ps	
Cumulative error across 6 cycles	t <sub>ERR</sub> (6per)	-139	139	-119	119	-104	104	-92	92	-83	83	ps	
Cumulative error across 7 cycles	t <sub>ERR</sub> (7per)	-145	145	-124	124	-109	109	-97	97	-87	87	ps	
Cumulative error across 8 cycles	t <sub>ERR</sub> (8per)	-151	151	-129	129	-113	113	-101	101	-91	91	ps	
Cumulative error across 9 cycles	t <sub>ERR</sub> (9per)	-156	156	-134	134	-117	117	-104	104	-94	94	ps	
Cumulative error across 10 cycles	t <sub>ERR</sub> (10per)	-160	160	-137	137	-120	120	-107	107	-96	96	ps	
Cumulative error across 11 cycles	t <sub>ERR</sub> (11per)	-164	164	-141	141	-123	123	-110	110	-99	99	ps	
Cumulative error across 12 cycles	t <sub>ERR</sub> (12per)	-168	168	-144	144	-126	126	-112	112	-101	101	ps	
Cumulative error across 13 cycles	t <sub>ERR</sub> (13per)	-172	172	-147	147	-129	129	-114	114	-103	103	ps	
Cumulative error across 14 cycles	t <sub>ERR</sub> (14per)	-175	175	-150	150	-131	131	-116	116	-104	104	ps	
Cumulative error across 15 cycles	t <sub>ERR</sub> (15per)	-178	178	-152	152	-133	133	-118	118	-106	106	ps	
Cumulative error across 16 cycles	t <sub>ERR</sub> (16per)	-180	189	-155	155	-135	135	-120	120	-108	108	ps	
Cumulative error across 17 cycles	t <sub>ERR</sub> (17per)	-183	183	-157	157	-137	137	-122	122	-110	110	ps	
Cumulative error across 18 cycles	t <sub>ERR</sub> (18per)	-185	185	-159	159	-139	139	-124	124	-112	112	ps	
Cumulative error across n = 13, 14 . . . 49, 50 cycles	t <sub>ERR</sub> (nper)	t <sub>ERR</sub> (nper)min = ((1 + 0.68ln(n)) * t <sub>JIT</sub> (per)_total min) t <sub>ERR</sub> (nper)max = ((1 + 0.68ln(n)) * t <sub>JIT</sub> (per)_total max)										ps	
Command and Address setup time to CK_t, CK_c referenced to Vih(ac) / Vil(ac) levels	t <sub>IS</sub> (base)	115	-	100	-	80	-	62	-	TBD	-	ps	
Command and Address setup time to CK_t, CK_c referenced to Vref levels	t <sub>IS</sub> (Vref)	215	-	200	-	180	-	162	-	TBD	-	ps	
Command and Address hold time to CK_t, CK_c referenced to Vih(dc) / Vil(dc) levels	t <sub>IH</sub> (base)	140	-	125	-	105	-	87	-	TBD	-	ps	
Command and Address hold time to CK_t, CK_c referenced to Vref levels	t <sub>IH</sub> (Vref)	215	-	200	-	180	-	162	-	TBD	-	ps	
Control and Address Input pulse width for each input	t <sub>IPW</sub>	600	-	525	-	460	-	410	-	385	-	ps	
<b>Command and Address Timing</b>													
CAS_n to CAS_n command delay for same bank group	t <sub>CCD_L</sub>	max(5 nCK, 6.250 ns)	-	max(5 nCK, 5.355 ns)	-	max(5 nCK, 5.625 ns)	-	max(5 nCK, 5 ns)	-	max(5 nCK, 5 ns)	-	nCK	34
CAS_n to CAS_n command delay for different bank group	t <sub>CCD_S</sub>	4	-	4	-	4	-	4	-	4	-	nCK	34
ACTIVATE to ACTIVATE Command delay to different bank group for 2KB page size	t <sub>RRD_S</sub> (2K)	Max(4nCK, 6ns)	-	Max(4nCK, 5.3ns)	-	Max(4nCK, 5.3ns)	-	Max(4nCK, 5.3ns)	-	Max(4nCK, 5.3ns)	-	nCK	34
ACTIVATE to ACTIVATE Command delay to different bank group for 2KB page size	t <sub>RRD_S</sub> (1K)	Max(4nCK, 5ns)	-	Max(4nCK, 4.2ns)	-	Max(4nCK, 3.7ns)	-	Max(4nCK, 3.3ns)	-	Max(4nCK, 3ns)	-	nCK	34

Speed		DDR4-1600		DDR4-1866		DDR4-2133		DDR4-2400		DDR4-2666		Units	NOTE
Parameter	Symbol	MIN	MAX	MIN	MAX	MIN	MAX	MIN	MAX	MIN	MAX		
ACTIVATE to ACTIVATE Command delay to different bank group for 1/2KB page size	tRRD_S(1/2K)	Max(4nC K,5ns)		Max(4nC K,4.2ns)		Max(4nC K,3.7ns)		Max(4nC K,3.3ns)	-	Max(4nC K,3ns)	-	nCK	34
ACTIVATE to ACTIVATE Command delay to same bank group for 2KB page size	tRRD_L(2K)	Max(4nC K,7.5ns)		Max(4nC K,6.4ns)		Max(4nC K,6.4ns)		Max(4nC K,6.4ns)	-	Max(4nC K,6.4ns)	-	nCK	34
ACTIVATE to ACTIVATE Command delay to same bank group for 1KB page size	tRRD_L(1K)	Max(4nC K,6ns)		Max(4nC K,5.3ns)		Max(4nC K,5.3ns)		Max(4nC K,4.9ns)	-	Max(4nC K,4.9ns)	-	nCK	34
ACTIVATE to ACTIVATE Command delay to same bank group for 1/2KB page size	tRRD_L(1/2K)	Max(4nC K,6ns)		Max(4nC K,5.3ns)		Max(4nC K,5.3ns)		Max(4nC K,4.9ns)	-	Max(4nC K,4.9ns)	-	nCK	34
Four activate window for 2KB page size	tFAW_2K	Max(28n CK,35ns)		Max(28n CK,30ns)		Max(28n CK,30ns)		Max(28n CK,30ns)	-	Max(28n CK,30ns)	-	ns	34
Four activate window for 1KB page size	tFAW_1K	Max(20n CK,25ns)		Max(20n CK,23ns)		Max(20n CK,21ns)		Max(20n CK,21ns)	-	Max(20n CK,21ns)	-	ns	34
Four activate window for 1/2KB page size	tFAW_1/2K	Max(16n CK,20ns)		Max(16n CK,17ns)		Max(16n CK,15ns)		Max(16n CK,13ns)	-	Max(16n CK,12ns)	-	ns	34
Delay from start of internal write transaction to internal read command for different bank group	tWTR_S	max(2nC K,2.5ns)	-	max(2nC K,2.5ns)	-	max(2nC K,2.5ns)	-	max(2nC K,2.5ns)	-	max(2nC K,2.5ns)	-	ns	1,2,e,3 4
Delay from start of internal write transaction to internal read command for same bank group	tWTR_L	max(4nC K,7.5ns)	-	max(4nC K,7.5ns)	-	max(4nC K,7.5ns)	-	max(4nC K,7.5ns)	-	max(4nC K,7.5ns)	-	ns	1,34
Internal READ Command to PRECHARGE Command delay	tRTP	max(4nC K,7.5ns)	-	max(4nC K,7.5ns)	-	max(4nC K,7.5ns)	-	max(4nC K,7.5ns)	-	max(4nC K,7.5ns)	-	ns	34
WRITE recovery time	tWR	15	-	15	-	15	-	15	-	15	-	ns	1
Write recovery time when CRC and DM are enabled	tWR_CRC_DM	tWR+max(4nC K,3.75ns)	-	tWR+max(5nC K,3.75ns)	-	tWR+max(5nC K,3.75ns)	-	tWR+max(5nC K,3.75ns)	-	tWR+max(5nC K,3.75ns)	-	ns	1, 28
delay from start of internal write transaction to internal read command for different bank group with both CRC and DM enabled	tWTR_S_C RC_DM	tWTR_S+max(4nC K,3.75ns)	-	tWTR_S+max(5nC K,3.75ns)	-	tWTR_S+max(5nC K,3.75ns)	-	tWTR_S+max(5nC K,3.75ns)	-	tWTR_S+max(5nC K,3.75ns)	-	ns	2, 29, 34
delay from start of internal write transaction to internal read command for same bank group with both CRC and DM enabled	tWTR_L_C RC_DM	tWTR_L+max(4nC K,3.75ns)	-	tWTR_L+max(5nC K,3.75ns)	-	tWTR_L+max(5nC K,3.75ns)	-	tWTR_L+max(5nC K,3.75ns)	-	tWTR_L+max(5nC K,3.75ns)	-	ns	3,30, 34
DLL locking time	tDLLK	597	-	597	-	768	-	768	-	854	-	nCK	
Mode Register Set command cycle time	tMRD	8	-	8	-	8	-	8	-	8	-	nCK	
Mode Register Set command update delay	tMOD	max(24n CK,15ns)	-	max(24n CK,15ns)	-	max(24n CK,15ns)	-	max(24n CK,15ns)	-	max(24n CK,15ns)	-	nCK	
Multi-Purpose Register Recovery Time	tMPRR	1	-	1	-	1	-	1	-	1	-	nCK	33
Multi Purpose Register Write Recovery Time	tWR_MPR	tMOD (min) + AL + PL	-	tMOD (min) + AL + PL	-	tMOD (min) + AL + PL	-	tMOD (min) + AL + PL	-	tMOD (min) + AL + PL	-	nCK	
Auto precharge write recovery + precharge time	tDAL(min)	Programmed WR + roundup ( tRP / tCK(avg) )										nCK	
DQ0 or DQL0 driven to 0 set-up time to first DQS rising edge	tPDA_S	0.5	-	0.5	-	0.5	-	0.5	-	0.5	-	UI	45,47
DQ0 or DQL0 driven to 0 hold time from last DQS fall-ing edge	tPDA_H	0.5	-	0.5	-	0.5	-	0.5	-	0.5	-	UI	46,47
<b>CS_n to Command Address Latency</b>													
CS_n to Command Address Latency	tCAL	3	-	4	-	4	-	max(3 nCK, 3.748 ns)	-	max(3 nCK, 3.748 ns)	-	nCK	
Mode Register Set cyce time in CAL mode	tMRD_tCAL							tMOD+tCAL	-	tMOD+tCAL	-	nCK	
Mode Register Set update delay in CAL mode	tMOD_tCAL							tMOD+tCAL	-	tMOD+tCAL	-	nCK	
<b>DRAM Data Timing</b>													
DQS_t,DQS_c to DQ skew, per group, per access	tDQSQ	-	0.16	-	0.16	-	0.16	-	0.16	-	0.18	tCK(avg)/2	13,18,3 9,49
DQ output hold per group, per access from DQS_t,DQS_c	tQH	0.76	-	0.76	-	0.76	-	0.74	-	0.74	-	tCK(avg)/2	13,17,1 8,39,49
Data Valid Window per device: (tQH - tD-QSQ) of each UI on a given DRAM	tDVWd	0.63	-	0.63	-	0.64	-	0.64	-	TBD	-	UI	17,18,3 9,49
Data Valid Window , per pin per UI : (tQH - tDQSQ) each UI on a pin of a given DRAM	tDVWp	0.66	-	0.66	-	0.69	-	0.72	-	0.72	-	UI	17,18,3 9,49
DQ low impedance time from CK_t, CK_c	tLZ(DQ)	-450	225	-390	195	-390	180	-330	175	-310	170	ps	39
DQ high impedance time from CK_t, CK_c	tHZ(DQ)	-	225	-	195	-	180	-	175	-	170	ps	39
<b>Data Strobe Timing</b>													

Speed		DDR4-1600		DDR4-1866		DDR4-2133		DDR4-2400		DDR4-2666		Units	NOTE
Parameter	Symbol	MIN	MAX	MIN	MAX	MIN	MAX	MIN	MAX	MIN	MAX		
DQS_t, DQS_c differential READ Preamble	tRPRE	0.9	NOTE44	0.9	NOTE44	0.9	NOTE44	0.9	NOTE44	0.9	NOTE44	tCK	39,40
		NA	NA	NA	NA	NA	NA	1.8	NOTE44	1.8	NOTE44	tCK	39,41
DQS_t, DQS_c differential READ Postamble	tRPST	0.33	NOTE 45	0.33	NOTE 45	0.33	NOTE 45	0.33	NOTE 45	0.33	NOTE 45	tCK	39
DQS_t, DQS_c differential output high time	tQSH	0.4	-	0.4	-	0.4	-	0.4	-	0.4	-	tCK	21,39
DQS_t, DQS_c differential output low time	tQSL	0.4	-	0.4	-	0.4	-	0.4	-	0.4	-	tCK	20,39
DQS_t, DQS_c differential WRITE Preamble	tWPRE	0.9	-	0.9	-	0.9	-	0.9	-	0.9	-	tCK	42
		NA	-	NA	-	NA	-	1.8	-	1.8	-	tCK	43
DQS_t, DQS_c differential WRITE Postamble	tWPST	0.33	-	0.33	-	0.33	-	0.33	-	0.33	-	tCK	
DQS_t and DQS_c low-impedance time (Referenced from RL-1)	tLZ(DQS)	-450	225	-390	195	-360	180	-330	175	-310	170	ps	39
DQS_t and DQS_c high-impedance time (Referenced from RL+BL/2)	tHZ(DQS)	-	225	-	195	-	180	-	175	-	170	ps	39
DQS_t, DQS_c differential input low pulse width	tDQSL	0.46	0.54	0.46	0.54	0.46	0.54	0.46	0.54	0.46	0.54	tCK	
DQS_t, DQS_c differential input high pulse width	tDQSH	0.46	0.54	0.46	0.54	0.46	0.54	0.46	0.54	0.46	0.54	tCK	
DQS_t, DQS_c rising edge to CK_t, CK_c rising edge (1 clock preamble)	tDQSS	-0.27	0.27	-0.27	0.27	-0.27	0.27	-0.27	0.27	-0.27	0.27	tCK	
DQS_t, DQS_c falling edge setup time to CK_t, CK_c rising edge	tDSS	0.18	-	0.18	-	0.18	-	0.18	-	0.18	-	tCK	
DQS_t, DQS_c falling edge hold time from CK_t, CK_c rising edge	tDSH	0.18	-	0.18	-	0.18	-	0.18	-	0.18	-	tCK	
DQS_t, DQS_c rising edge output timing location from rising CK_t, CK_c with DLL On mode	tDQSK (DLL On)	-225	225	-195	195	-180	180	-175	175	-170	170	ps	37,38,39
DQS_t, DQS_c rising edge output variance window per DRAM	tDQSKI (DLL On)	-	370	-	330	-	310	-	290	-	270	ps	37,38,39
<b>MPSM Timing</b>													
Command path disable delay upon MPSM entry	tMPED	tMOD(min) + tCP-DED(min)	-	tMOD(min) + tCP-DED(min)	-	tMOD(min) + tCP-DED(min)	-	tMOD(min) + tCP-DED(min)	-	TBD	-		
Valid clock requirement after MPSM entry	tCKMPE	tMOD(min) + tCP-DED(min)	-	tMOD(min) + tCP-DED(min)	-	tMOD(min) + tCP-DED(min)	-	tMOD(min) + tCP-DED(min)	-	TBD	-		
Valid clock requirement before MPSM exit	tCKMPX	tCKSRX(min)	-	tCKSRX(min)	-	tCKSRX(min)	-	tCKSRX(min)	-	TBD	-		
Exit MPSM to commands not requiring a locked DLL	tXMP	tXS(min)	-	tXS(min)	-	tXS(min)	-	tXS(min)	-	TBD	-		
Exit MPSM to commands requiring a locked DLL	tXMPDLL	tXMP(min) + tXS-DLL(min)	-	tXMP(min) + tXS-DLL(min)	-	tXMP(min) + tXS-DLL(min)	-	tXMP(min) + tXS-DLL(min)	-	TBD	-		
CS setup time to CKE	tMPX_S	tIS(min) + tIHL(min)	-	tIS(min) + tIHL(min)	-	tIS(min) + tIHL(min)	-	tIS(min) + tIHL(min)	-	TBD	-		
<b>Calibration Timing</b>													
Power-up and RESET calibration time	tZQinit	1024	-	1024	-	1024	-	1024	-	1024	-	nCK	
Normal operation Full calibration time	tZQoper	512	-	512	-	512	-	512	-	512	-	nCK	
Normal operation Short calibration time	tZQCS	128	-	128	-	128	-	128	-	128	-	nCK	
<b>Reset/Self Refresh Timing</b>													
Exit Reset from CKE HIGH to a valid command	tXPR	max(5nCK, tRFC(min)+10ns)	-	max(5nCK, tRFC(min)+10ns)	-	max(5nCK, tRFC(min)+10ns)	-	max(5nCK, tRFC(min)+10ns)	-	max(5nCK, tRFC(min)+10ns)	-	nCK	
Exit Self Refresh to commands not requiring a locked DLL	tXS	tRFC(min)+10ns	-	tRFC(min)+10ns	-	tRFC(min)+10ns	-	tRFC(min)+10ns	-	tRFC(min)+10ns	-	nCK	
SRX to commands not requiring a locked DLL in Self Refresh ABORT	tX-S_ABORT(min)	tRFC4(min)+10ns	-	tRFC4(min)+10ns	-	tRFC4(min)+10ns	-	tRFC4(min)+10ns	-	tRFC4(min)+10ns	-	nCK	
Exit Self Refresh to ZQCL, ZQCS and MRS (CL, CWL, WR, RTP and Gear Down)	tXS_FAST(min)	tRFC4(min)+10ns	-	tRFC4(min)+10ns	-	tRFC4(min)+10ns	-	tRFC4(min)+10ns	-	tRFC4(min)+10ns	-	nCK	
Exit Self Refresh to commands requiring a locked DLL	tXSDLL	tDLLK(min)	-	tDLLK(min)	-	tDLLK(min)	-	tDLLK(min)	-	tDLLK(min)	-	nCK	
Minimum CKE low width for Self refresh entry to exit timing	tCKESR	tCKE(min)+1nCK	-	tCKE(min)+1nCK	-	tCKE(min)+1nCK	-	tCKE(min)+1nCK	-	tCKE(min)+1nCK	-	nCK	

Speed		DDR4-1600		DDR4-1866		DDR4-2133		DDR4-2400		DDR4-2666		Units	NOTE
Parameter	Symbol	MIN	MAX	MIN	MAX	MIN	MAX	MIN	MAX	MIN	MAX		
Minimum CKE low width for Self refresh entry to exit timing with CA Parity enabled	tCKESR_PAR	tCKE(min)+1nCK+PL	-	tCKE(min)+1nCK+PL	-	tCKE(min)+1nCK+PL	-	tCKE(min)+1nCK+PL	-	tCKE(min)+1nCK+PL	-	nCK	
Valid Clock Requirement after Self Refresh Entry (SRE) or Power-Down Entry (PDE)	tCKSRE	max(5nCK, 10ns)	-	max(5nCK, 10ns)	-	max(5nCK, 10ns)	-	max(5nCK, 10ns)	-	max(5nCK, 10ns)	-	nCK	
Valid Clock Requirement after Self Refresh Entry (SRE) or Power-Down when CA Parity is enabled	tCKSRE_PAR	max(5nCK, 10ns)+PL	-	max(5nCK, 10ns)+PL	-	max(5nCK, 10ns)+PL	-	max(5nCK, 10ns)+PL	-	max(5nCK, 10ns)+PL	-	nCK	
Valid Clock Requirement before Self Refresh Exit (SRX) or Power-Down Exit (PDX) or Reset Exit	tCKSRX	max(5nCK, 10ns)	-	max(5nCK, 10ns)	-	max(5nCK, 10ns)	-	max(5nCK, 10ns)	-	max(5nCK, 10ns)	-	nCK	
<b>Power Down Timing</b>													
Exit Power Down with DLL on to any valid command; Exit Precharge Power Down with DLL frozen to commands not requiring a locked DLL	tXP	max(4nCK, 6ns)	-	max(4nCK, 6ns)	-	max(4nCK, 6ns)	-	max(4nCK, 6ns)	-	max(4nCK, 6ns)	-	nCK	
CKE minimum pulse width	tCKE	max(3nCK, 5ns)	-	max(3nCK, 5ns)	-	max(3nCK, 5ns)	-	max(3nCK, 5ns)	-	max(3nCK, 5ns)	-	nCK	31,32
Command pass disable delay	tCPDED	4	-	4	-	4	-	4	-	4	-	nCK	
Power Down Entry to Exit Timing	tPD	tCKE(min)	9*tREFI	tCKE(min)	9*tREFI	tCKE(min)	9*tREFI	tCKE(min)	9*tREFI	tCKE(min)	9*tREFI	nCK	6
Timing of ACT command to Power Down entry	tACTPDEN	1	-	1	-	2	-	2	-	2	-	nCK	7
Timing of PRE or PREA command to Power Down entry	tPRPDEN	1	-	1	-	2	-	2	-	2	-	nCK	7
Timing of RD/RDA command to Power Down entry	tRDPDEN	RL+4+1	-	RL+4+1	-	RL+4+1	-	RL+4+1	-	RL+4+1	-	nCK	
Timing of WR command to Power Down entry (BL8OTF, BL8MRS, BC4OTF)	tWRPDEN	WL+4+(tWR/tCK(avg))	-	WL+4+(tWR/tCK(avg))	-	WL+4+(tWR/tCK(avg))	-	WL+4+(tWR/tCK(avg))	-	WL+4+(tWR/tCK(avg))	-	nCK	4
Timing of WRA command to Power Down entry (BL8OTF, BL8MRS, BC4OTF)	tWRAPDEN	WL+4+WR+1	-	WL+4+WR+1	-	WL+4+WR+1	-	WL+4+WR+1	-	WL+4+WR+1	-	nCK	5
Timing of WR command to Power Down entry (BC4MRS)	tWRP-BC4DEN	WL+2+(tWR/tCK(avg))	-	WL+2+(tWR/tCK(avg))	-	WL+2+(tWR/tCK(avg))	-	WL+2+(tWR/tCK(avg))	-	WL+2+(tWR/tCK(avg))	-	nCK	4
Timing of WRA command to Power Down entry (BC4MRS)	tWRAP-BC4DEN	WL+2+WR+1	-	WL+2+WR+1	-	WL+2+WR+1	-	WL+2+WR+1	-	WL+2+WR+1	-	nCK	5
Timing of REF command to Power Down entry	tREFPDEN	1	-	1	-	2	-	2	-	2	-	nCK	7
Timing of MRS command to Power Down entry	tMRSPDEN	tMOD(min)	-	tMOD(min)	-	tMOD(min)	-	tMOD(min)	-	tMOD(min)	-	nCK	
<b>PDA Timing</b>													
Mode Register Set command cycle time in PDA mode	tMRD_PDA	max(16nCK, 10ns)	-	max(16nCK, 10ns)	-	max(16nCK, 10ns)	-	max(16nCK, 10ns)	-	max(16nCK, 10ns)	-	nCK	
Mode Register Set command update delay in PDA mode	tMOD_PDA	tMOD		tMOD		tMOD		tMOD		tMOD		nCK	
<b>ODT Timing</b>													
Asynchronous RTT turn-on delay (Power-Down with DLL frozen)	tAONAS	1.0	9.0	1.0	9.0	1.0	9.0	1.0	9.0	1.0	9.0	ns	
Asynchronous RTT turn-off delay (Power-Down with DLL frozen)	tAOFAS	1.0	9.0	1.0	9.0	1.0	9.0	1.0	9.0	1.0	9.0	ns	
RTT dynamic change skew	tADC	0.3	0.7	0.3	0.7	0.3	0.7	0.3	0.7	0.3	0.7	tCK(avg)	
<b>Write Leveling Timing</b>													
First DQS <sub>t</sub> /DQS <sub>n</sub> rising edge after write leveling mode is programmed	tWLMRD	40	-	40	-	40	-	40	-	40	-	nCK	12
DQS <sub>t</sub> /DQS <sub>n</sub> delay after write leveling mode is programmed	tWLDQSEN	25	-	25	-	25	-	25	-	25	-	nCK	12
Write leveling setup time from rising CK <sub>t</sub> , CK <sub>c</sub> crossing to rising DQS <sub>t</sub> /DQS <sub>n</sub> crossing	tWLS	0.13	-	0.13	-	0.13	-	0.13	-	0.13	-	tCK(avg)	
Write leveling hold time from rising DQS <sub>t</sub> /DQS <sub>n</sub> crossing to rising CK <sub>t</sub> , CK <sub>c</sub> crossing	tWLH	0.13	-	0.13	-	0.13	-	0.13	-	0.13	-	tCK(avg)	
Write leveling output delay	tWLO	0	9.5	0	9.5	0	9.5	0	9.5	0	9.5	ns	
Write leveling output error	tWLOE	0	2	0	2	0	2	0	2	0	2	ns	
<b>CA Parity Timing</b>													
Commands not guaranteed to be executed during this time	tPAR_UN-KNOWN	-	PL	-	PL	-	PL	-	PL	-	PL	nCK	

Speed		DDR4-1600		DDR4-1866		DDR4-2133		DDR4-2400		DDR4-2666		Units	NOTE
Parameter	Symbol	MIN	MAX	MIN	MAX	MIN	MAX	MIN	MAX	MIN	MAX		
Delay from errant command to ALERT_n assertion	tPAR_ALERT_ON	-	PL+6ns	-	PL+6ns	-	PL+6ns	-	PL+6ns	-	PL+6ns	nCK	
Pulse width of ALERT_n signal when asserted	tPAR_ALERT_PW	48	96	56	112	64	128	72	144	80	160	nCK	
Time from when Alert is asserted till controller must start providing DES commands in Persistent CA parity mode	tPAR_ALERT_RSP	-	43	-	50	-	57	-	64	-	71	nCK	
Parity Latency	PL	4		4		4		5		5		nCK	
<b>CRC Error Reporting</b>													
CRC error to ALERT_n latency	tCRC_ALERT	3	13	3	13	3	13	3	13	3	13	ns	
CRC ALERT_n pulse width	CRC_ALERT_PW	6	10	6	10	6	10	6	10	6	10	nCK	
<b>Geardown timing</b>													
Exit RESET from CKE HIGH to a valid MRS geardown (T2/Reset)	tXPR_GEAR	-	-	-	-	-	-	-	-	TBD			
CKE High Assert to Gear Down Enable time(T2/CKE)	tXS_GEAR	-	-	-	-	-	-	-	-	TBD			
MRS command to Sync pulse time(T3)	tSYNC_GEAR	-	-	-	-	-	-	-	-	TBD	-		27
Sync pulse to First valid command(T4)	tCMD_GEAR	-	-	-	-	-	-	-	-	TBD			27
Geardown setup time	tGEAR_setup	-	-	-	-	-	-	-	-	2	-	nCK	
Geardown hold time	tGEAR_hold	-	-	-	-	-	-	-	-	2	-	nCK	
<b>tREFI</b>													
tRFC1 (min)	2Gb	160	-	160	-	160	-	160	-	160	-	ns	34
	4Gb	260	-	260	-	260	-	260	-	260	-	ns	34
	8Gb	350	-	350	-	350	-	350	-	350	-	ns	34
	16Gb	TBD	-	TBD	-	TBD	-	550	-	550	-	ns	34
tRFC2 (min)	2Gb	110	-	110	-	110	-	110	-	110	-	ns	34
	4Gb	160	-	160	-	160	-	160	-	160	-	ns	34
	8Gb	260	-	260	-	260	-	260	-	260	-	ns	34
	16Gb	TBD	-	TBD	-	TBD	-	350	-	350	-	ns	34
tRFC4 (min)	2Gb	90	-	90	-	90	-	90	-	90	-	ns	34
	4Gb	110	-	110	-	110	-	110	-	110	-	ns	34
	8Gb	160	-	160	-	160	-	160	-	160	-	ns	34
	16Gb	TBD	-	TBD	-	TBD	-	260	-	260	-	ns	34

**NOTE :**

1. Start of internal write transaction is defined as follows :  
 For BL8 (Fixed by MRS and on-the-fly) : Rising clock edge 4 clock cycles after WL.  
 For BC4 (on-the-fly) : Rising clock edge 4 clock cycles after WL.  
 For BC4 (fixed by MRS) : Rising clock edge 2 clock cycles after WL.
2. A separate timing parameter will cover the delay from write to read when CRC and DM are simultaneously enabled
3. Commands requiring a locked DLL are: READ (and RAP) and synchronous ODT commands.
4. tWR is defined in ns, for calculation of tWRPDEN it is necessary to round up tWR/tCK to the next integer.
5. WR in clock cycles as programmed in MR0.
6. tREFI depends on TOPER.
7. tKE is allowed to be registered low while operations such as row activation, precharge, autoprecharge or refresh are in progress, but power-down IDD spec will not be applied until finishing those operations.
8. For these parameters, the DDR4 SDRAM device supports tnPARAM[nCK]=RU{tPARAM[ns]/tCK(avg)[ns]}, which is in clock cycles assuming all input clock jitter specifications are satisfied
9. When CRC and DM are both enabled, tWR\_CRC\_DM is used in place of tWR.
10. When CRC and DM are both enabled tWTR\_S\_CRC\_DM is used in place of tWTR\_S.
11. When CRC and DM are both enabled tWTR\_L\_CRC\_DM is used in place of tWTR\_L.
12. The max values are system dependent.
13. DQ to DQS total timing per group where the total includes the sum of deterministic and random timing terms for a specified BER. BER spec and measurement method are tbd.
14. The deterministic component of the total timing. Measurement method tbd.
15. DQ to DQ static offset relative to strobe per group. Measurement method tbd.
16. This parameter will be characterized and guaranteed by design.
17. When the device is operated with the input clock jitter, this parameter needs to be derated by the actual tjit(per)\_total of the input clock. (output deratings are relative to the SDRAM input clock). Example tbd.
18. DRAM DBI mode is off.
19. DRAM DBI mode is enabled. Applicable to x8 and x16 DRAM only.
20. tQSL describes the instantaneous differential output low pulse width on DQS\_t - DQS\_c, as measured from on falling edge to the next consecutive rising edge
21. tQSH describes the instantaneous differential output high pulse width on DQS\_t - DQS\_c, as measured from on falling edge to the next consecutive rising edge
22. There is no maximum cycle time limit besides the need to satisfy the refresh interval tREFI
23. tCH(abs) is the absolute instantaneous clock high pulse width, as measured from one rising edge to the following falling edge
24. tCL(abs) is the absolute instantaneous clock low pulse width, as measured from one falling edge to the following rising edge
25. Total jitter includes the sum of deterministic and random jitter terms for a specified BER. BER target and measurement method are tbd.
26. The deterministic jitter component out of the total jitter. This parameter is characterized and guaranteed by design.
27. This parameter has to be even number of clocks
28. When CRC and DM are both enabled, tWR\_CRC\_DM is used in place of tWR.
29. When CRC and DM are both enabled tWTR\_S\_CRC\_DM is used in place of tWTR\_S.
30. When CRC and DM are both enabled tWTR\_L\_CRC\_DM is used in place of tWTR\_L.
31. After tCKE is registered LOW, tCKE signal level shall be maintained below VIHDC for tCKE specification ( Low pulse width ).
32. After tCKE is registered HIGH, tCKE signal level shall be maintained above VIHDC for tCKE specification ( HIGH pulse width ).
33. Defined between end of MPR read burst and MRS which reloads MPR or disables MPR function.
34. Parameters apply from tCK(avg)min to tCK(avg)max at all standard JEDEC clock period values as stated in the Speed Bin Tables.
35. This parameter must keep consistency with Speed-Bin Tables .
36. DDR4-1600 AC timing apply if DRAM operates at lower than 1600 MT/s data rate.  
 $UI = tCK(avg).min/2$
37. applied when DRAM is in DLL ON mode.
38. Assume no jitter on input clock signals to the DRAM
39. Value is only valid for RZQ/7 RONNOM = 34 ohms
40. 1tCK toggle mode with setting MR4:A11 to 0
41. 2tCK toggle mode with setting MR4:A11 to 1, which is valid for DDR4-2400/2666/3200 speed grade.
42. 1tCK mode with setting MR4:A12 to 0
43. 2tCK mode with setting MR4:A12 to 1, which is valid for DDR4-2400/2666/3200 speed grade.
44. The maximum read preamble is bounded by tLZ(DQS)min on the left side and tDQSCK(max) on the right side.
45. DQ falling signal middle-point of transferring from High to Low to first rising edge of DQS diff-signal cross-point
46. last falling edge of DQS diff-signal cross-point to DQ rising signal middle-point of transferring from Low to High
47. VrefDQ value must be set to either its midpoint or Vcent\_DQ(midpoint) in order to capture DQ0 or DQL0 low level for entering PDA mode.
48. The maximum read postamble is bound by tDQSCK(min) plus tQSH(min) on the left side and tHZ(DQS)max on the right side.
49. Reference level of DQ output signal is specified with a midpoint as a widest part of Output signal eye which should be approximately 0.7 \* VDDQ as a center level of the static single-ended output peak-to-peak swing with a driver impedance of 34 ohms and an effective test load of 50 ohms to VTT = VDDQ .

### 14.4 The DQ input receiver compliance mask for voltage and timing

The DQ input receiver compliance mask for voltage and timing is shown in the figure below. The receiver mask (Rx Mask) defines area the input signal must not encroach in order for the DRAM input receiver to be expected to be able to successfully capture a valid input signal; it is not the valid data-eye.

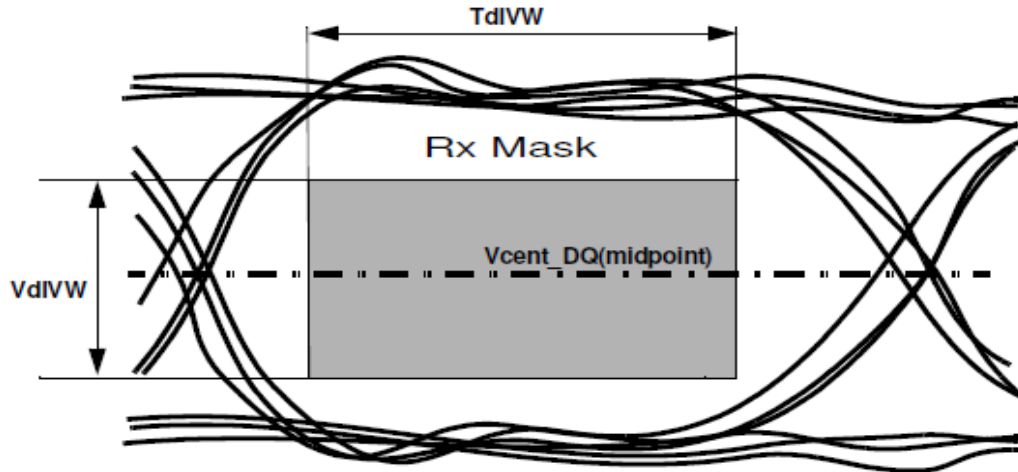

Figure 24. DQ Receiver(Rx) compliance mask

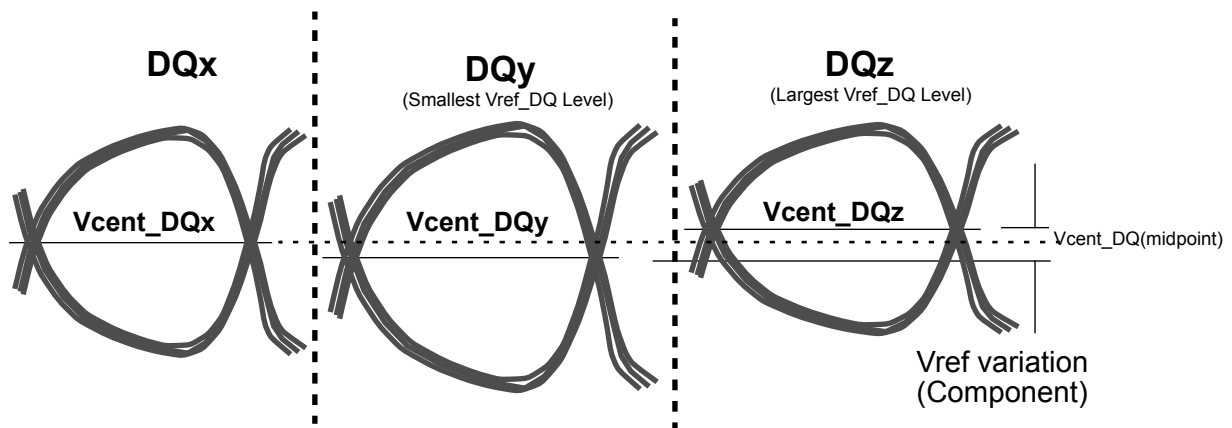
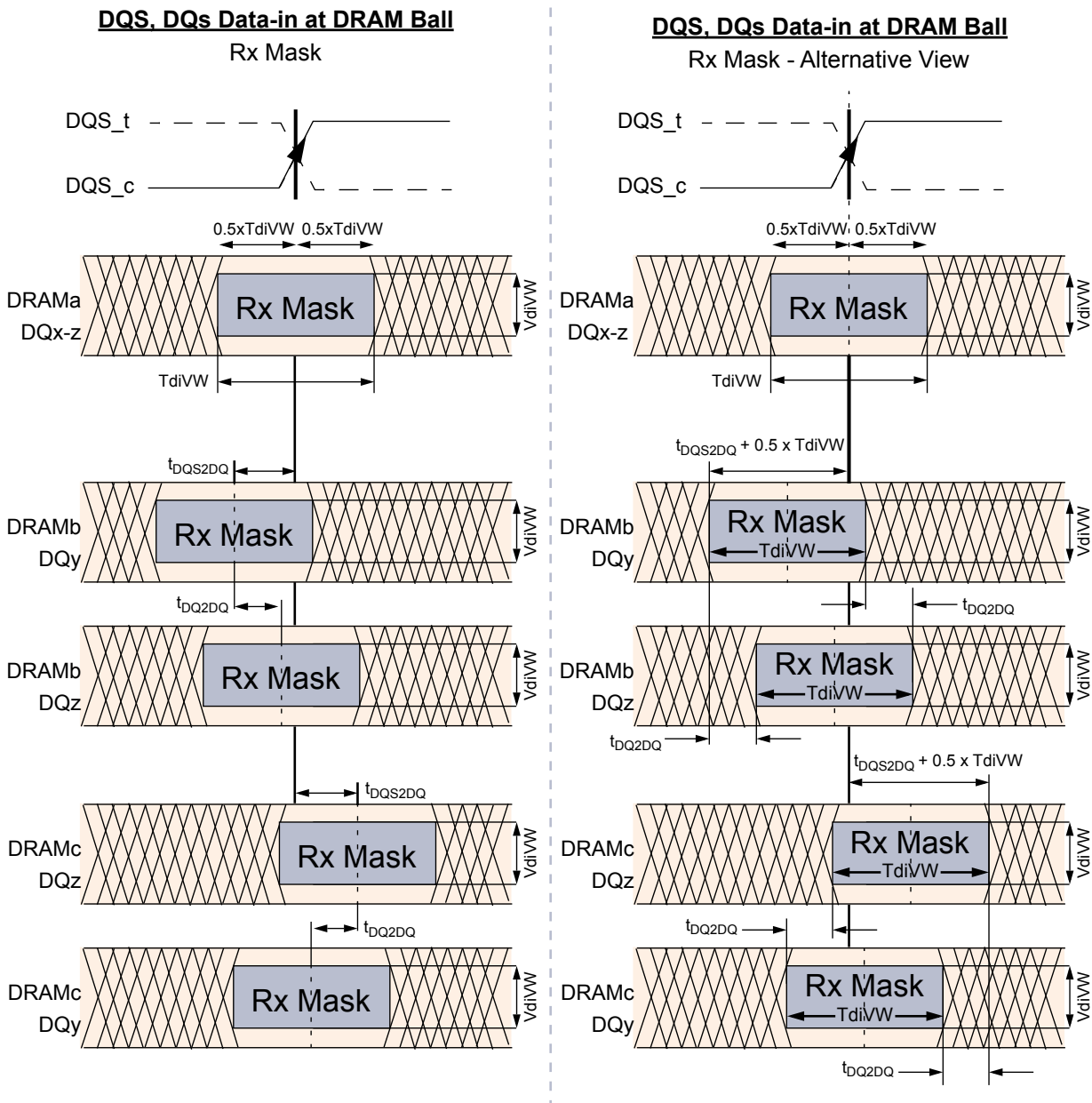

Figure 25. Across pin Vref DQ voltage variation

The Vref\_DQ voltage is an internal reference voltage level that shall be set to the properly trained setting, which is generally Vcent\_DQ(midpoint), in order to have valid Rx Mask values.

Vcent\_DQ is defined as the midpoint between the largest Vref\_DQ voltage level and the smallest Vref\_DQ voltage level across all DQ pins for a given DDR4 DRAM component. Each DQ pin Vref level is defined by the center, i.e. widest opening, of the cumulative data input eye as depicted in Figure 24. This clarifies that any DDR4 DRAM component level variation must be accounted for within the DDR4 DRAM Rx mask. The component level Vref will be set by the system to account for Ron and ODT settings.



NOTE : DQx represents an optimally centered mask.  
 DQy represents earliest valid mask.  
 DQz represents latest valid mask.

NOTE : DRAMa represents a DRAM without any DQS/DQ skews.  
 DRAMB represents a DRAM with early skews (negative  $t_{DQS2DQ}$ ).

NOTE : Figures show skew allowed between DRAM to DRAM and DQ to DQ for a DRAM. Signals assume data centered aligned at DRAM Latch.  
 TdiPW is not shown; composite data-eyes shown would violate TdiPW.  
 VCENT DQ(midpoint) is not shown but is assumed to be midpoint of VdiVW..

Figure 26. DQS to DQ and DQ to DQ Timings at DRAM Balls

All of the timing terms in Figure 26 are measured at the VdiVW<sub>total</sub> voltage levels centered around Vcent\_DQ(midpoint) and are referenced to the DQS<sub>t</sub>/DQS<sub>c</sub> center aligned to the DQ per pin.

The rising edge slew rates are defined by  $srr1$  and  $srr2$ . The slew rate measurement points for a rising edge are shown in Figure 5A below: A low to high transition  $tr1$  is measured from  $0.5 \cdot V_{dIVW(max)}$  below  $V_{cent\_DQ(midpoint)}$  to the last transition through  $0.5 \cdot V_{dIVW(max)}$  above  $V_{cent\_DQ(midpoint)}$  while  $tr2$  is measured from the last transition through  $0.5 \cdot V_{dIVW(max)}$  above  $V_{cent\_DQ(midpoint)}$  to the first transition through the  $0.5 \cdot V_{IHL\_AC(min)}$  above  $V_{cent\_DQ(midpoint)}$ .

Rising edge slew rate equations:

$$srr1 = V_{dIVW(max)} / tr1$$

$$srr2 = (V_{IHL\_AC(min)} - V_{dIVW(max)}) / (2 \cdot tr2)$$

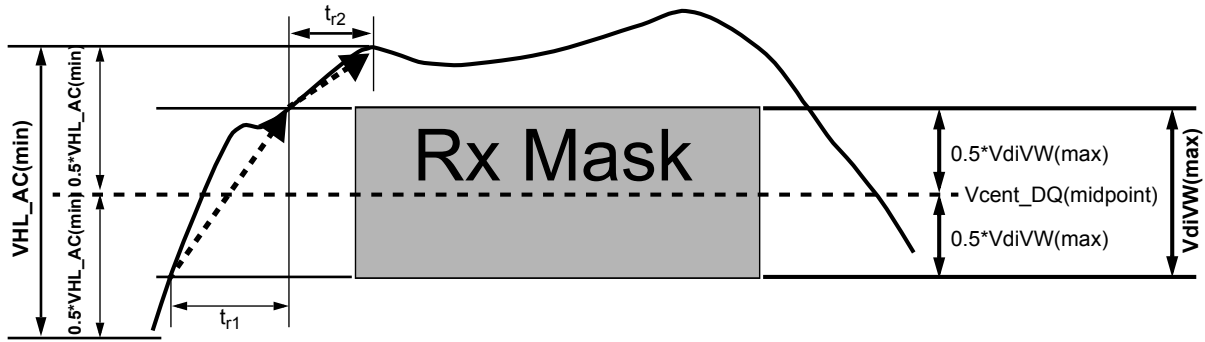

Figure 27. Slew Rate Conditions For Rising Transition

The falling edge slew rates are defined by  $srf1$  and  $srf2$ . The slew rate measurement points for a falling edge are shown in Figure 5B below: A high to low transition  $tf1$  is measured from  $0.5 \cdot V_{dIVW(max)}$  above  $V_{cent\_DQ(midpoint)}$  to the last transition through  $0.5 \cdot V_{dIVW(max)}$  below  $V_{cent\_DQ(midpoint)}$  while  $tf2$  is measured from the last transition through  $0.5 \cdot V_{dIVW(max)}$  below  $V_{cent\_DQ(midpoint)}$  to the first transition through the  $0.5 \cdot V_{IHL\_AC(min)}$  below  $V_{cent\_DQ(pin\ mid)}$ .

Falling edge slew rate equations:

$$srf1 = V_{dIVW(max)} / tf1$$

$$srf2 = (V_{IHL\_AC(min)} - V_{dIVW(max)}) / (2 \cdot tf2)$$

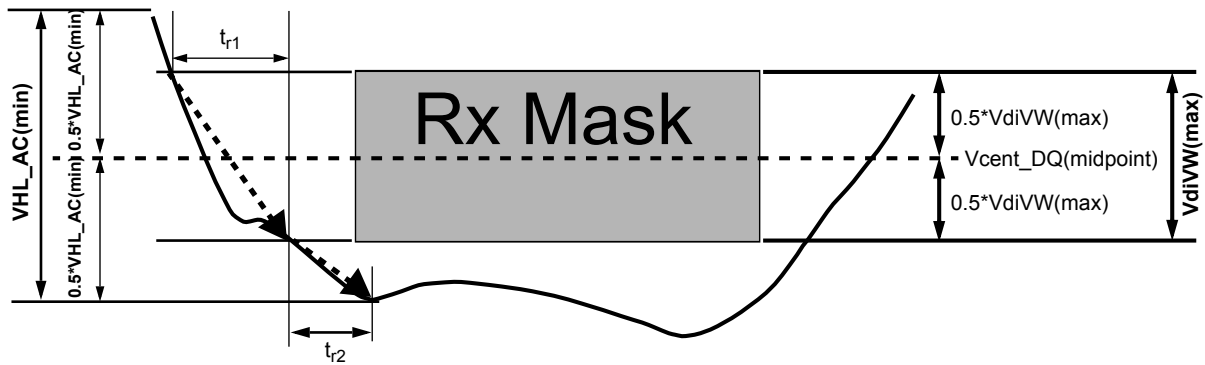

Figure 28. Slew Rate Conditions For Falling Transition

[ Table 54 ] DRAM DQs In Receive Mode; \* UI=tck(avg)min/2

Symbol	Parameter	1600/1866/2133		2400		2666		Unit	NOTE
		min	max	min	max	min	max		
VdIVW	Rx Mask voltage - pk-pk	-	136	-	130	-	120	mV	1,2,10
TdIVW	Rx timing window	-	0.2	-	0.2	-	0.22	UI*	1,2,10
VIHL_AC	DQ AC input swing pk-pk	186	-	160	-	150	-	mV	3,4,10
TdIPW	DQ input pulse width	0.58		0.58		0.58	-	UI*	5,10
tDQS2DQ	Rx Mask DQS to DQ offset	-0.17	0.17	-0.17	0.17	-0.19	0.19	UI*	6, 10
tDQ2DQ	Rx Mask DQ to DQ offset	-	tbd	-	tbd	-	0.105	UI*	7
srr1, srf1	Input Slew Rate over VdIVW if tCK >= 0.935ns	1.0	9	1.0	9	1.0	tbd	V/ns	8,10
	Input Slew Rate over VdIVW if 0.935ns > tCK >= 0.625ns	-	-	1.25	9	1.25	tbd	V/ns	8,10
srr2	Rising Input Slew Rate over 1/2 VIHL_AC	0.2*srr1	9	0.2*srr1	9	0.2*srr1	tbd	V/ns	9,10
srf2	Falling Input Slew Rate over 1/2 VIHL_AC	0.2*srf1	9	0.2*srf1	9	0.2*srf1	tbd	V/ns	9,10

**NOTE :**

1. Data Rx mask voltage and timing total input valid window where VdIVW is centered around Vcent\_DQ( midpoint) after VrefDQ training is completed. The data Rx mask is applied per bit and should include voltage and temperature drift terms. The input buffer design specification is to achieve at least a BER = e-16 when the RxMask is not violated. The BER will be characterized and extrapolated if necessary using a dual dirac method from a higher BER(tbd).
2. Defined over the DQ internal Vref range 1.
3. See Overshoot and Undershoot Specifications.
4. DQ input pulse signal swing into the receiver must meet or exceed VIHL AC(min). . VIHL\_AC(min) is to be achieved on an UI basis when a rising and falling edge occur in the same UI, i.e. a valid TdIPW.
5. DQ minimum input pulse width defined at the Vcent\_DQ( midpoint).
6. DQS to DQ offset is skew between DQS and DQs within a nibble (x4) or word (x8, x16) at the DDR4 SDRAM balls over process, voltage, and temperature.
7. DQ to DQ offset is skew between DQs within a nibble (x4) or word (x8, x16) at the DDR4 SDRAM balls for a given component over process, voltage, and temperature.
8. Input slew rate over VdIVW Mask centered at Vcent\_DQ( midpoint). Slowest DQ slew rate to fastest DQ slew rate per transition edge must be within 1.7 V/ns of each other.
9. Input slew rate between VdIVW Mask edge and VIHL\_AC(min) points.
10. All Rx Mask specifications must be satisfied for each UI. For example, if the minimum input pulse width is violated when satisfying TdIVW(min), VdIVW(max), and minimum slew rate limits, then either TdIVW(min) or minimum slew rates would have to be increased to the point where the minimum input pulse width would no longer be violated.

## 14.5 DDR4 Function Matrix

DDR4 SDRAM has several features supported by ORG and also by Speed. The following Table is the summary of the features.

[ Table 55 ] Function Matrix (By ORG. V:Supported, Blank:Not supported)

Functions	x4	x8	x16	NOTE
Write Leveling	√	√	√	
Temperature controlled Refresh	√	√	√	
Low Power Auto Self Refresh	√	√	√	
Fine Granularity Refresh	√	√	√	
Multi Purpose Register	√	√	√	
Data Mask		√	√	
Data Bus Inversion		√	√	
TDQS		√		
ZQ calibration	√	√	√	
DQ Vref Training	√	√	√	
Per DRAM Addressability	√	√	√	
Mode Register Readout	√	√	√	
CAL	√	√	√	
WRITE CRC	√	√	√	
CA Parity	√	√	√	
Control Gear Down Mode	√	√	√	
Programmable Preamble	√	√	√	
Maximum Power Down Mode	√	√		
Boundary Scan Mode			√	
Additive Latency	√	√		
3DS	√	√		

[ Table 56 ] Function Matrix (By Speed. V:Supported, Blank:Not supported)

Functions	DLL Off mode	DLL On mode			NOTE
	equal or slower than 250Mbps	1600/1866/2133 Mbps	2400Mbps	2666Mbps	
Write Leveling	V	V	V	V	
Temperature controlled Refresh	V	V	V	V	
Low Power Auto Self Refresh	V	V	V	V	
Fine Granularity Refresh	V	V	V	V	
Multi Purpose Register	V	V	V	V	
Data Mask	V	V	V	V	
Data Bus Inversion	V	V	V	V	
TDQS		V	V	V	
ZQ calibration	V	V	V	V	
DQ Vref Training	V	V	V	V	
Per DRAM Addressability		V	V	V	
Mode Register Readout	V	V	V	V	
CAL		V	V	V	
WRITE CRC		V	V	V	
CA Parity		V	V	V	
Control Gear Down Mode				V	
Programmable Preamble ( = 2tCK)			V	V	
Maximum Power Down Mode		V	V	V	
Boundary Scan Mode	V	V	V	V	
3DS	V	V	V	V	