

Features

- Temperature ranges
 - Commercial: 0 °C to +70 °C
 - Industrial: -40 °C to +85 °C
 - Automotive-A: -40 °C to +85 °C
 - Automotive-E: -40 °C to +125 °C
- High speed: 55 ns
- Voltage range: 4.5 V to 5.5 V operation
- Low active power
 - 275 mW (max)
- Low standby power (LL version)
 - 82.5 μW (max)
- Easy memory expansion with \overline{CE} and \overline{OE} Features
- TTL-compatible inputs and outputs
- Automatic power-down when deselected
- CMOS for optimum speed and power
- Available in Pb-free and non Pb-free 28-pin (600-mil) PDIP, 28-pin (300-mil) narrow SOIC, 28-pin TSOP-I, and 28-pin reverse TSOP-I packages

Functional Description

The CY62256N is a high performance CMOS static RAM organized as 32K words by 8 bits. Easy memory expansion is provided by an active LOW chip enable (\overline{CE}) and active LOW output enable (\overline{OE}) and tristate drivers. This device has an automatic power-down feature, reducing the power consumption by 99.9 percent when deselected.

An active LOW write enable signal (\overline{WE}) controls the writing/reading operation of the memory. When \overline{CE} and \overline{WE} inputs are both LOW, data on the eight data input/output pins (I/O_0 through I/O_7) is written into the memory location addressed by the address present on the address pins (A_0 through A_{14}). Reading the device is accomplished by selecting the device and enabling the outputs, \overline{CE} and \overline{OE} active LOW, while \overline{WE} remains inactive or HIGH. Under these conditions, the contents of the location addressed by the information on address pins are present on the eight data input/output pins.

The input/output pins remain in a high impedance state unless the chip is selected, outputs are enabled, and write enable (\overline{WE}) is HIGH.

Logic Block Diagram

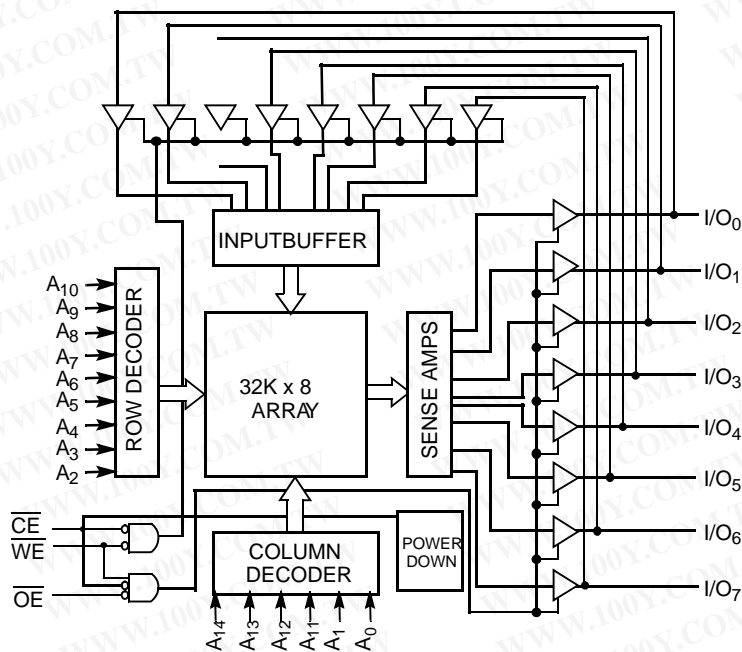

Contents

Product Portfolio	3	Ordering Information	11
Pin Configurations	3	Ordering Code Definitions	11
Maximum Ratings	4	Package Diagrams	12
Operating Range	4	Reference Information	14
Electrical Characteristics	4	Acronyms	14
Capacitance	4	Document Conventions	14
Thermal Resistance	5	Document History Page	15
Data Retention Characteristics	5	Sales, Solutions, and Legal Information	16
Switching Characteristics	6	Worldwide Sales and Design Support	16
Switching Waveforms	6	Products	16
Typical DC and AC Characteristics	9	PSoC Solutions	16
Truth Table	10		

Product Portfolio

Product		V _{CC} Range (V)			Speed (ns)	Power Dissipation			
						Operating, I _{CC} (mA)		Standby, I _{SB2} (μA)	
		Min	Typ ^[1]	Max		Typ ^[1]	Max	Typ ^[1]	Max
CY62256NLL	Commercial	4.5	5.0	5.5	70	25	50	0.1	5
CY62256NLL	Industrial				55/70	25	50	0.1	10
CY62256NLL	Automotive-A				55/70	25	50	0.1	10
CY62256NLL	Automotive-E				55	25	50	0.1	15

Pin Configurations

Figure 1. 28-pin DIP and Narrow SOIC

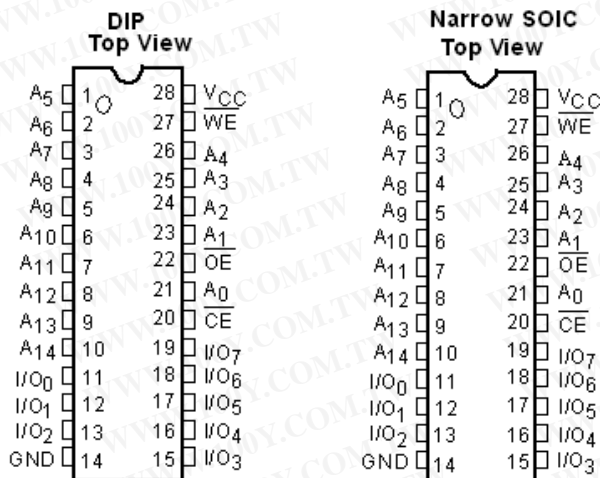

Figure 2. 28-pin TSOP I and Reverse TSOP I

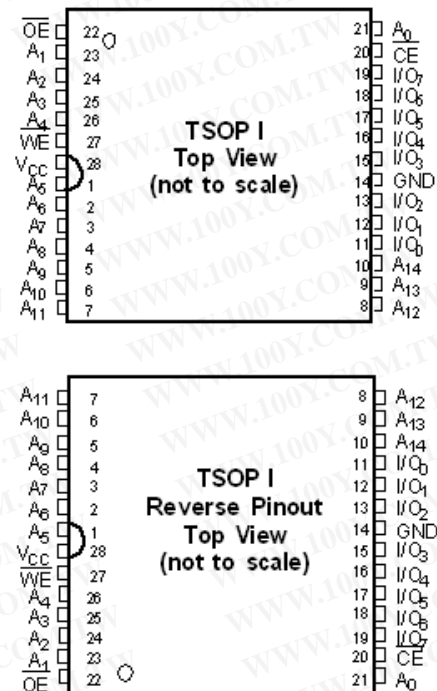

Table 1. Pin Definitions

Pin Number	Type	Description
1–10, 21, 23–26	Input	A₀–A₁₄ . Address Inputs
11–13, 15–19,	Input/Output	I/O₀–I/O₇ . Data lines. Used as input or output lines depending on operation
27	Input/Control	WE . When selected LOW, a WRITE is conducted. When selected HIGH, a READ is conducted
20	Input/Control	CE . When LOW, selects the chip. When HIGH, deselects the chip
22	Input/Control	OE . Output Enable. Controls the direction of the I/O pins. When LOW, the I/O pins behave as outputs. When deasserted HIGH, I/O pins are tristated, and act as input data pins
14	Ground	GND . Ground for the device
28	Power Supply	V_{CC} . Power supply for the device

Note

- Typical specifications are the mean values measured over a large sample size across normal production process variations and are taken at nominal conditions (T_A = 25 °C, V_{CC}). Parameters are guaranteed by design and characterization, and not 100% tested.

Maximum Ratings

Exceeding maximum ratings may impair the useful life of the device. These user guidelines are not tested.

Storage temperature -65 °C to +150 °C
 Ambient temperature with power applied -55 °C to +125 °C
 Supply voltage to ground potential (pin 28 to pin 14).....-0.5 V to +7.0 V
 DC voltage applied to outputs in high Z State^[2]-0.5 V to V_{CC} + 0.5 V
 DC input voltage^[2]-0.5 V to V_{CC} + 0.5 V
 Output current into outputs (LOW) 20 mA

Static discharge voltage..... > 2001 V (per MIL-STD-883, method 3015)

Latch-up current > 200 mA

Operating Range

Range	Ambient Temperature (T _A) ^[3]	V _{CC}
Commercial	0 °C to +70 °C	5 V ± 10%
Industrial	-40 °C to +85 °C	5 V ± 10%
Automotive-A	-40 °C to +85 °C	5 V ± 10%
Automotive-E	-40 °C to +125 °C	5 V ± 10%

Electrical Characteristics

Over the Operating Range

Parameter	Description	Test Conditions	-55			-70			Unit	
			Min	Typ ^[4]	Max	Min	Typ ^[4]	Max		
V _{OH}	Output HIGH voltage	V _{CC} = Min, I _{OH} = -1.0 mA	2.4	-	-	2.4	-	-	V	
V _{OL}	Output LOW voltage	V _{CC} = Min, I _{OL} = 2.1 mA	-	-	0.4	-	-	0.4	V	
V _{IH}	Input HIGH voltage		2.2	-	V _{CC} + 0.5 V	2.2	-	V _{CC} + 0.5 V	V	
V _{IL}	Input LOW voltage		-0.5	-	0.8	-0.5	-	0.8	V	
I _{IX}	Input leakage current	GND ≤ V _I ≤ V _{CC}	-0.5	-	+0.5	-0.5	-	+0.5	μA	
I _{OZ}	Output leakage current	GND ≤ V _O ≤ V _{CC} , output disabled	-0.5	-	+0.5	-0.5	-	+0.5	μA	
I _{CC}	V _{CC} operating supply current	V _{CC} = Max, I _{OUT} = 0 mA, f = f _{MAX} = 1/t _{RC}	LL-Commercial	-	-	-	-	25	50	mA
			LL - Industrial	-	25	50	-	25	50	mA
			LL - Automotive-A	-	25	50	-	25	50	mA
			LL - Automotive-E	-	25	50	-	-	-	mA
I _{SB1}	Automatic CE power-down current—TTL inputs	Max. V _{CC} , CE ≥ V _{IH} , V _{IN} ≥ V _{IH} or V _{IN} ≤ V _{IL} , f = f _{MAX}	LL-Commercial	-	-	-	-	0.3	0.5	mA
			LL - Industrial	-	0.3	0.5	-	0.3	0.5	mA
			LL - Automotive-A	-	0.3	0.5	-	0.3	0.5	mA
			LL - Automotive-E	-	0.3	0.5	-	-	-	mA
I _{SB2}	Automatic CE power-down current—CMOS inputs	Max. V _{CC} , CE ≥ V _{CC} - 0.3 V, V _{IN} ≥ V _{CC} - 0.3 V, or V _{IN} ≤ 0.3 V, f = 0	LL - Commercial	-	-	-	-	0.1	5	μA
			LL - Industrial	-	0.1	10	-	0.1	10	μA
			LL - Automotive-A	-	0.1	10	-	0.1	10	μA
			LL - Automotive-E	-	0.1	15	-	-	-	μA

Capacitance

Parameter ^[5]	Description	Test Conditions	Max	Unit
C _{IN}	Input capacitance	T _A = 25 °C, f = 1 MHz, V _{CC} = 5.0 V	6	pF
C _{OUT}	Output capacitance		8	pF

Notes

- V_{IL} (min) = -2.0 V for pulse durations of less than 20 ns.
- T_A is the "Instant-On" case temperature.
- Typical specifications are the mean values measured over a large sample size across normal production process variations and are taken at nominal conditions (T_A = 25 °C, V_{CC}). Parameters are guaranteed by design and characterization, and not 100% tested.
- Tested initially and after any design or process changes that may affect these parameters.

Thermal Resistance

Parameter ^[6]	Description	Test Conditions	DIP	SOIC	TSOP	RTSOP	Unit
θ_{JA}	Thermal resistance (junction to ambient)	Still air, soldered on a 4.25 x 1.125 inch, 4-layer printed circuit board	75.61	76.56	93.89	93.89	°C/W
θ_{JC}	Thermal resistance (junction to case)		43.12	36.07	24.64	24.64	°C/W

Figure 3. AC Test Loads and Waveforms

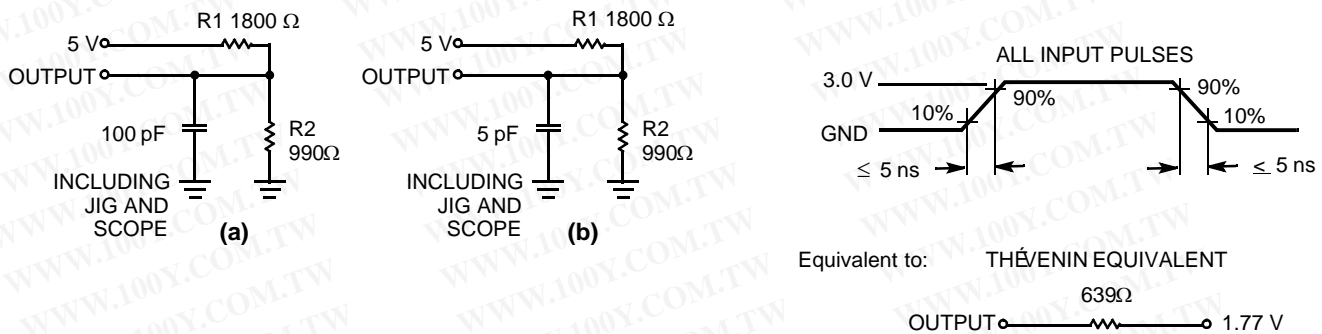

Data Retention Characteristics

Parameter	Description	Conditions ^[7]	Min	Typ ^[8]	Max	Unit	
V_{DR}	V_{CC} for data retention		2.0	–	–	V	
I_{CCDR}	Data retention current	LL – Commercial	$V_{CC} = 2.0\text{ V}$, $CE \geq V_{CC} - 0.3\text{ V}$, $V_{IN} \geq V_{CC} - 0.3\text{ V}$, or $V_{IN} \leq 0.3\text{ V}$	–	0.1	5	μA
		LL – Industrial/ Automotive-A		–	0.1	10	μA
		LL – Automotive-E		–	0.1	10	μA
$t_{CDR}^{[7]}$	Chip deselect to data retention time		0	–	–	ns	
$t_R^{[7]}$	Operation recovery time	CY62256NLL-55	55	–	–	ns	
		CY62256NLL-70	70	–	–		

Figure 4. Data Retention Waveform

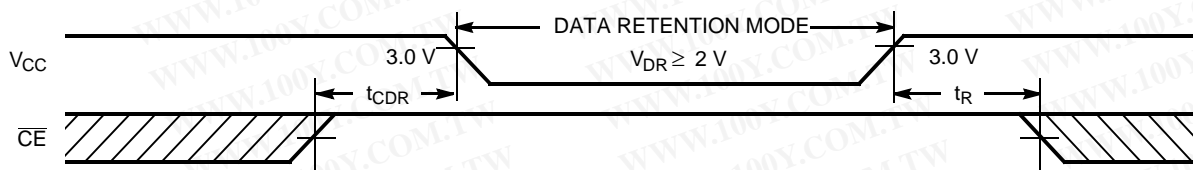

Notes

6. Tested initially and after any design or process changes that may affect these parameters.
7. No input may exceed $V_{CC} + 0.5\text{ V}$.
8. Typical specifications are the mean values measured over a large sample size across normal production process variations and are taken at nominal conditions ($T_A = 25\text{ }^\circ\text{C}$, V_{CC}). Parameters are guaranteed by design and characterization, and not 100% tested.

Switching Characteristics

Over the Operating Range

Parameter ^[9]	Description	CY62256N-55		CY62256N-70		Unit
		Min	Max	Min	Max	
Read Cycle						
t_{RC}	Read cycle time	55	–	70	–	ns
t_{AA}	Address to data valid	–	55	–	70	ns
t_{OHA}	Data hold from address change	5	–	5	–	ns
t_{ACE}	\overline{CE} LOW to data valid	–	55	–	70	ns
t_{DOE}	\overline{OE} LOW to data valid	–	25	–	35	ns
t_{LZOE}	\overline{OE} LOW to low Z ^[10]	5	–	5	–	ns
t_{HZOE}	\overline{OE} HIGH to high Z ^[10, 11]	–	20	–	25	ns
t_{LZCE}	\overline{CE} LOW to low Z ^[10]	5	–	5	–	ns
t_{HZCE}	\overline{CE} HIGH to high Z ^[10, 11]	–	20	–	25	ns
t_{PU}	\overline{CE} LOW to power-up	0	–	0	–	ns
t_{PD}	\overline{CE} HIGH to power-down	–	55	–	70	ns
Write Cycle^[12, 13]						
t_{WC}	Write cycle time	55	–	70	–	ns
t_{SCE}	\overline{CE} LOW to write end	45	–	60	–	ns
t_{AW}	Address setup to write end	45	–	60	–	ns
t_{HA}	Address hold from write end	0	–	0	–	ns
t_{SA}	Address setup to write start	0	–	0	–	ns
t_{PWE}	\overline{WE} pulse width	40	–	50	–	ns
t_{SD}	Data setup to write end	25	–	30	–	ns
t_{HD}	Data hold from write end	0	–	0	–	ns
t_{HZWE}	\overline{WE} LOW to high Z ^[10, 11]	–	20	–	25	ns
t_{LZWE}	\overline{WE} HIGH to low Z ^[10]	5	–	5	–	ns

Switching Waveforms

Figure 5. Read Cycle No. 1^[14, 15]

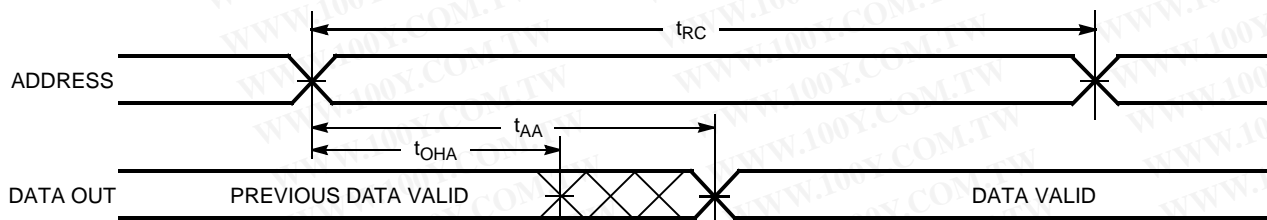

Notes

9. Test conditions assume signal transition time of 5 ns or less, timing reference levels of 1.5 V, input pulse levels of 0 to 3.0 V, and output loading of the specified I_{OL}/I_{OH} and 100-pF load capacitance.
10. At any temperature and voltage condition, t_{HZCE} is less than t_{LZCE} , t_{HZOE} is less than t_{LZOE} , and t_{HZWE} is less than t_{LZWE} for any device.
11. t_{HZOE} , t_{HZCE} , and t_{HZWE} are specified with $C_L = 5$ pF as in (b) of AC Test Loads. Transition is measured ± 500 mV from steady-state voltage.
12. The internal Write time of the memory is defined by the overlap of \overline{CE} LOW and \overline{WE} LOW. Both signals must be LOW to initiate a Write and either signal can terminate a Write by going HIGH. The data input setup and hold timing should be referenced to the rising edge of the signal that terminates the Write.
13. The minimum Write cycle time for Write Cycle #3 (\overline{WE} controlled, \overline{OE} LOW) is the sum of t_{HZWE} and t_{SD} .
14. Device is continuously selected. \overline{OE} , $\overline{CE} = V_{IL}$.
15. \overline{WE} is HIGH for Read cycle.

Switching Waveforms (continued)

Figure 6. Read Cycle No. 2^[16, 17]

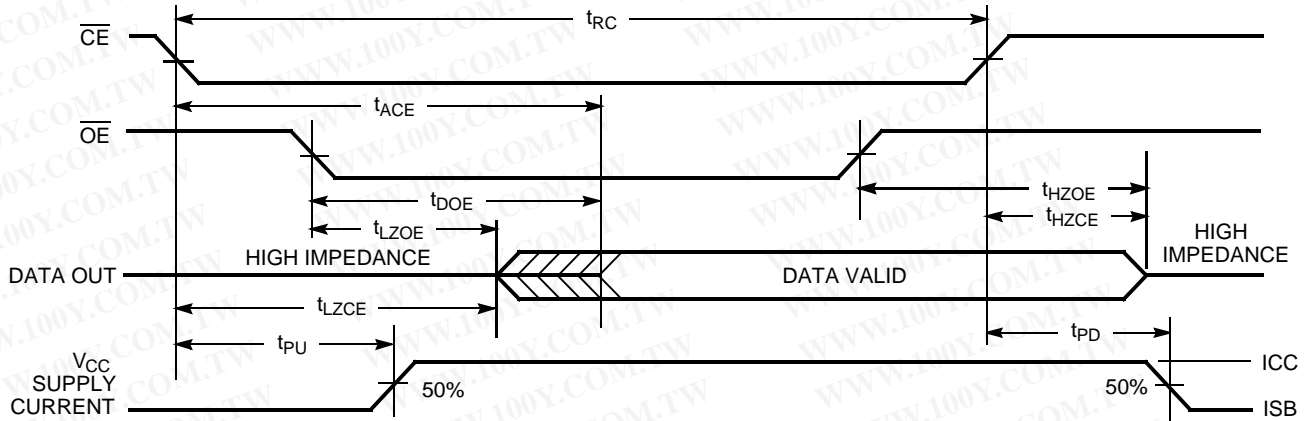

Figure 7. Write Cycle No. 1 (\overline{WE} Controlled)^[18, 19, 20]

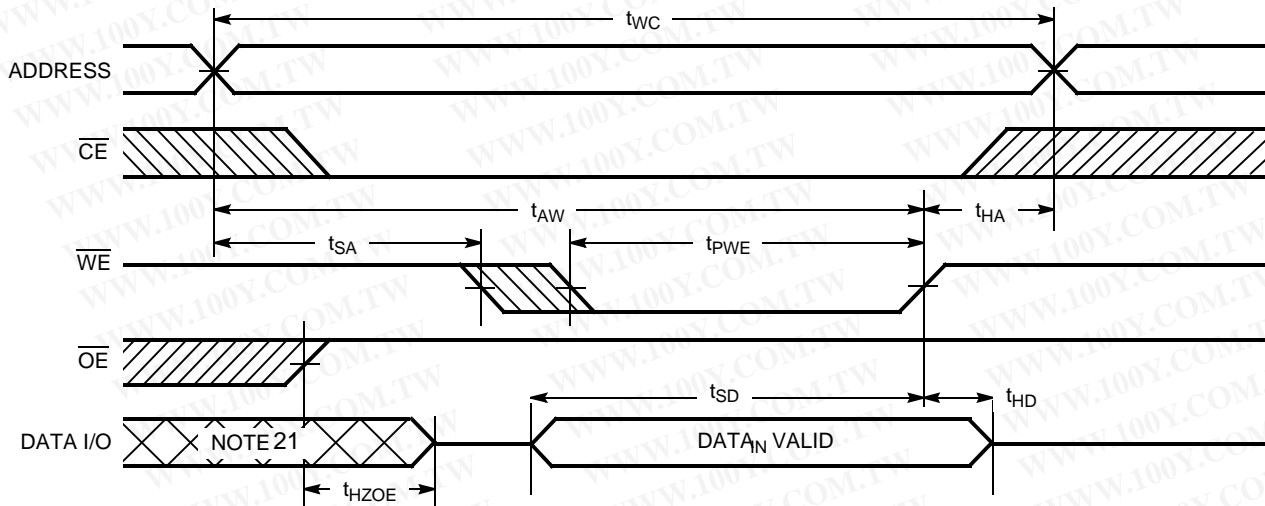
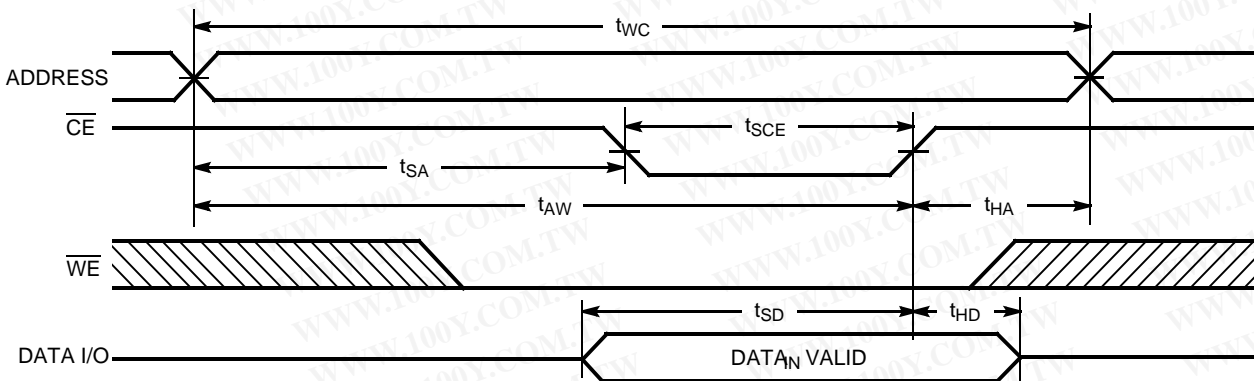

Figure 8. Write Cycle No. 2 (\overline{CE} Controlled)^[18, 19, 20]



Notes

16. \overline{WE} is HIGH for Read cycle.
17. Address valid prior to or coincident with \overline{CE} transition LOW.
18. The internal Write time of the memory is defined by the overlap of \overline{CE} LOW and \overline{WE} LOW. Both signals must be LOW to initiate a Write and either signal can terminate a Write by going HIGH. The data input setup and hold timing should be referenced to the rising edge of the signal that terminates the Write.
19. Data I/O is high impedance if $\overline{OE} = V_{IH}$.
20. If \overline{CE} goes HIGH simultaneously with \overline{WE} HIGH, the output remains in a high-impedance state.
21. During this period, the I/Os are in output state and input signals should not be applied.

Switching Waveforms (continued)

Figure 9. Write Cycle No. 3 (\overline{WE} Controlled, \overline{OE} LOW)^[22, 23]

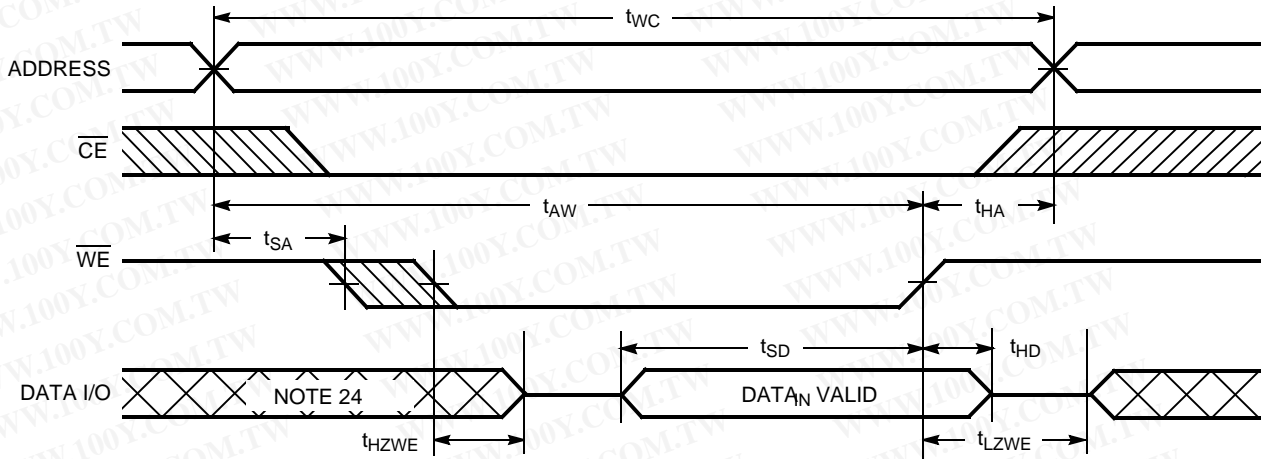

Notes

- 22. The minimum Write cycle time for Write Cycle #3 (\overline{WE} controlled, \overline{OE} LOW) is the sum of t_{HZWE} and t_{SD} .
- 23. If \overline{CE} goes HIGH simultaneously with \overline{WE} HIGH, the output remains in a high-impedance state.
- 24. During this period, the I/Os are in output state and input signals should not be applied.

Typical DC and AC Characteristics

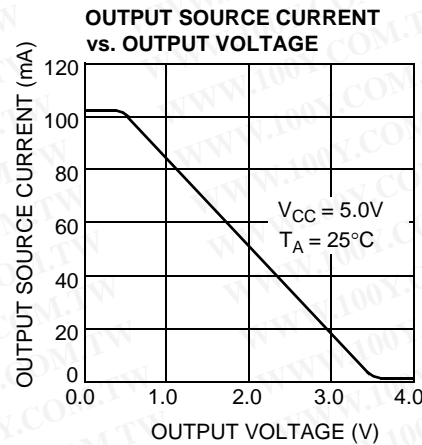
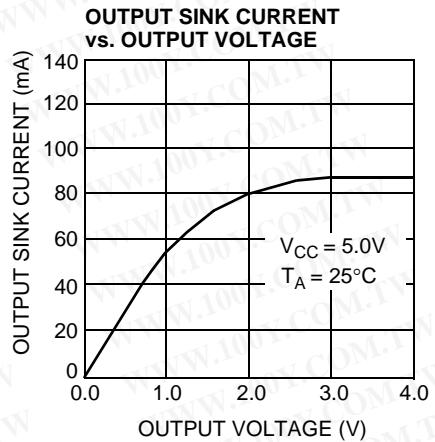
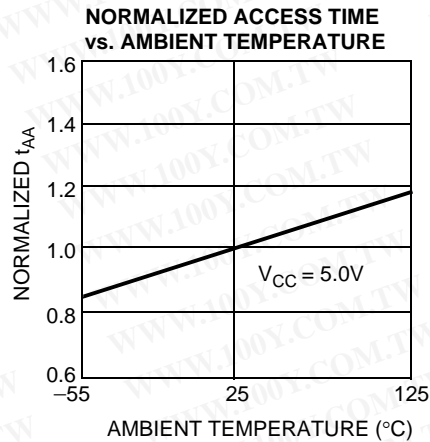
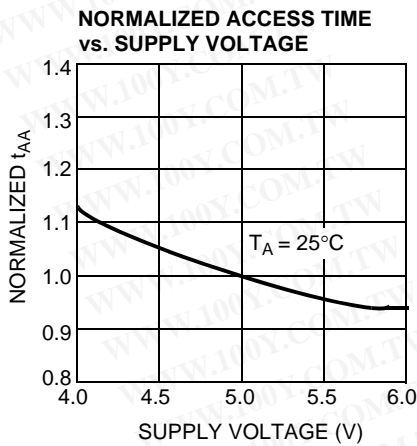
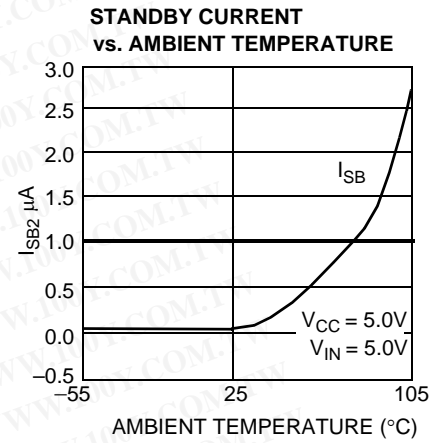
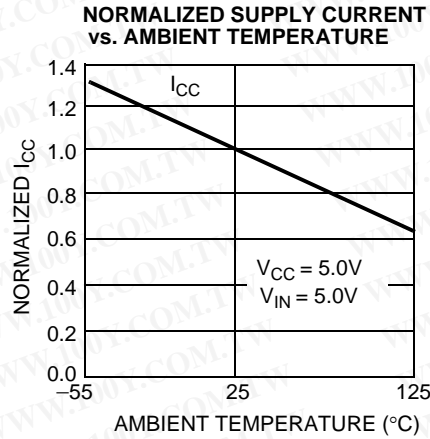
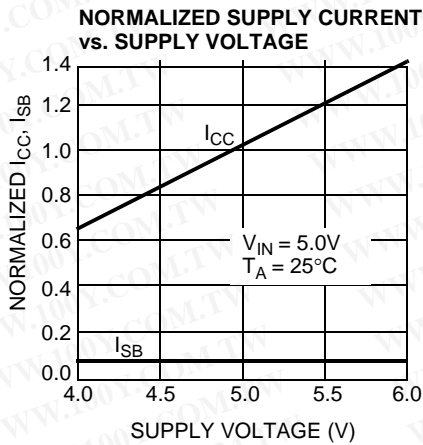

Typical DC and AC Characteristics (continued)

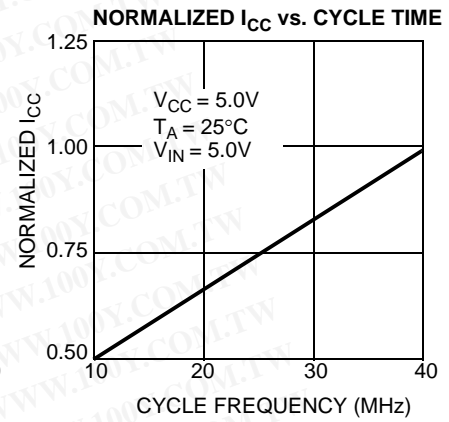
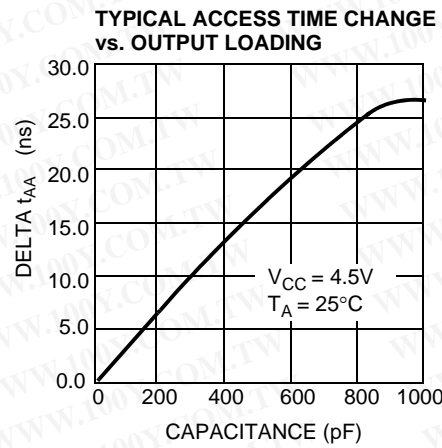
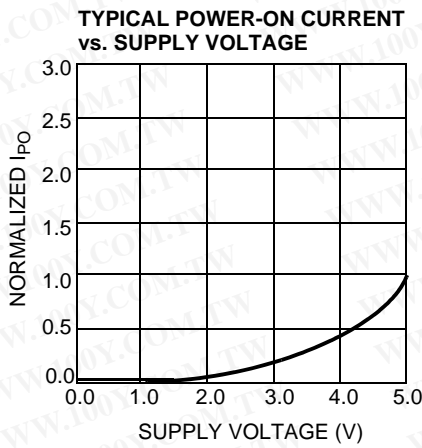

Truth Table

$\overline{\text{CE}}$	$\overline{\text{WE}}$	$\overline{\text{OE}}$	Inputs/Outputs	Mode	Power
H	X	X	High Z	Deselect/Power-down	Standby (I_{SB})
L	H	L	Data Out	Read	Active (I_{CC})
L	L	X	Data In	Write	Active (I_{CC})
L	H	H	High Z	Output Disabled	Active (I_{CC})

Ordering Information

Speed (ns)	Ordering Code	Package Diagram	Package Type	Operating Range
55	CY62256NLL-55SNXI	51-85092	28-pin (300-mil) narrow SOIC (Pb-free)	Industrial
	CY62256NLL-55ZXI	51-85071	28-pin TSOP I (Pb-free)	
	CY62256NLL-55ZXA	51-85071	28-pin TSOP I (Pb-free)	Automotive-A
	CY62256NLL-55SNXE	51-85092	28-pin (300-mil) narrow SOIC (Pb-free)	Automotive-E
	CY62256NLL-55ZXE	51-85071	28-pin TSOP I (Pb-free)	
70	CY62256NLL-70PXC	51-85017	28-pin (600-mil) molded DIP (Pb-free)	Commercial
	CY62256NLL-70SNXC	51-85092	28-pin (300-mil) narrow SOIC (Pb-free)	
	CY62256NLL-70ZRXI	51-85074	28-pin reverse TSOP I (Pb-free)	Industrial
	CY62256NLL-70SNXA	51-85092	28-pin (300-mil) narrow SOIC (Pb-free)	Automotive-A

Ordering Code Definitions

CY 62 256 N LL - XX XXX X

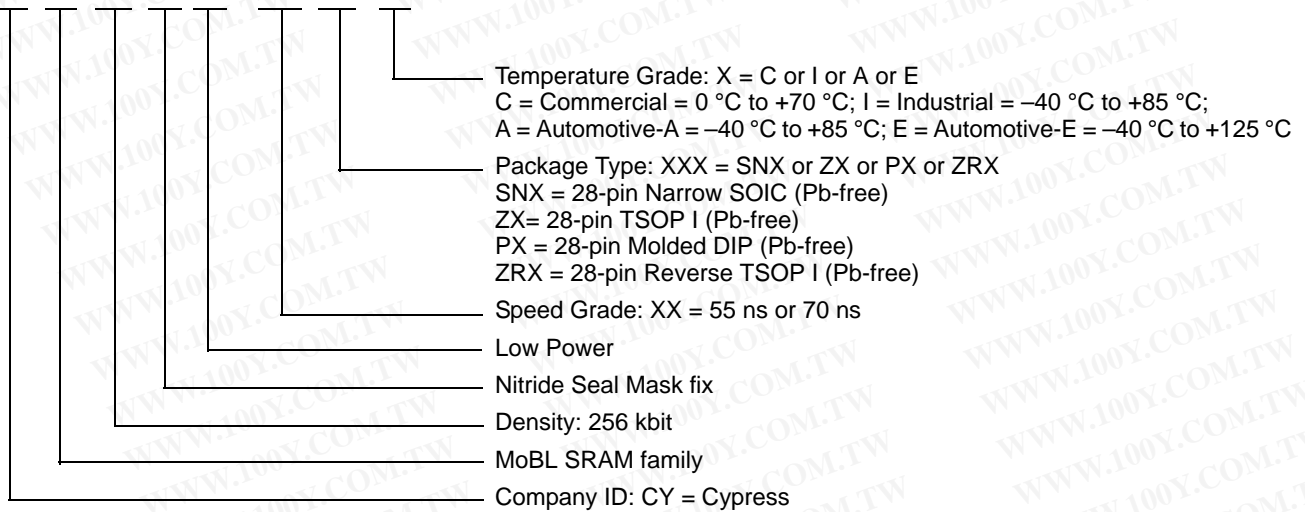

Package Diagrams

Figure 10. 28-pin (600-mil) Molded DIP, 51-85017

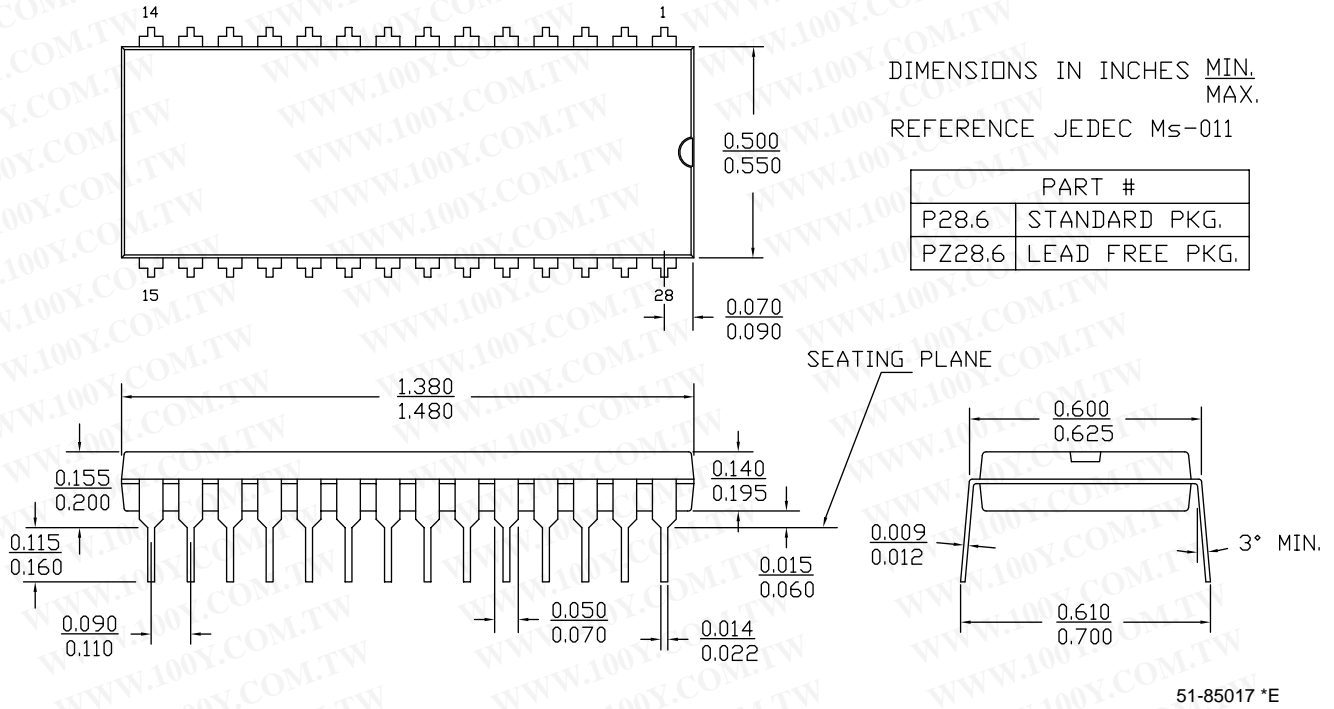

Figure 11. 28-pin (300-mil) SNC (Narrow Body), 51-85092

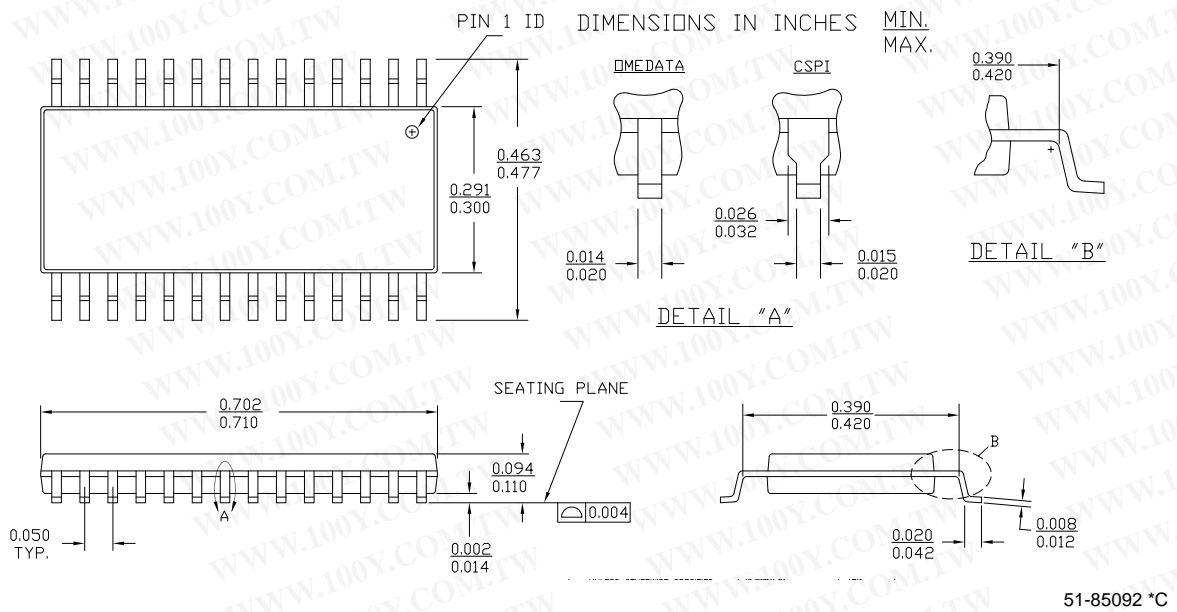

Figure 12. 28-pin TSOP I (8 × 13.4 mm), 51-85071

NOTE: ORIENTATION I.D. MAY BE LOCATED EITHER AS SHOWN IN OPTION 1 OR OPTION 2

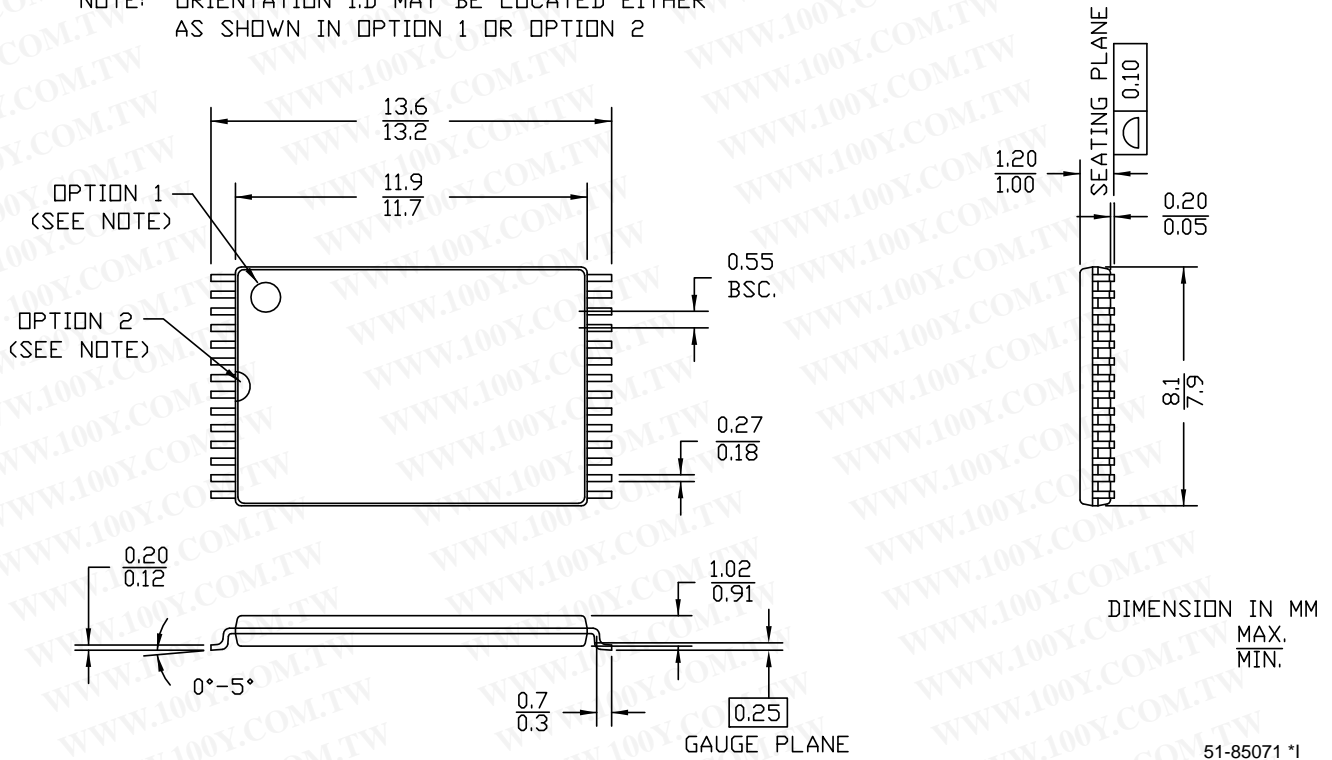
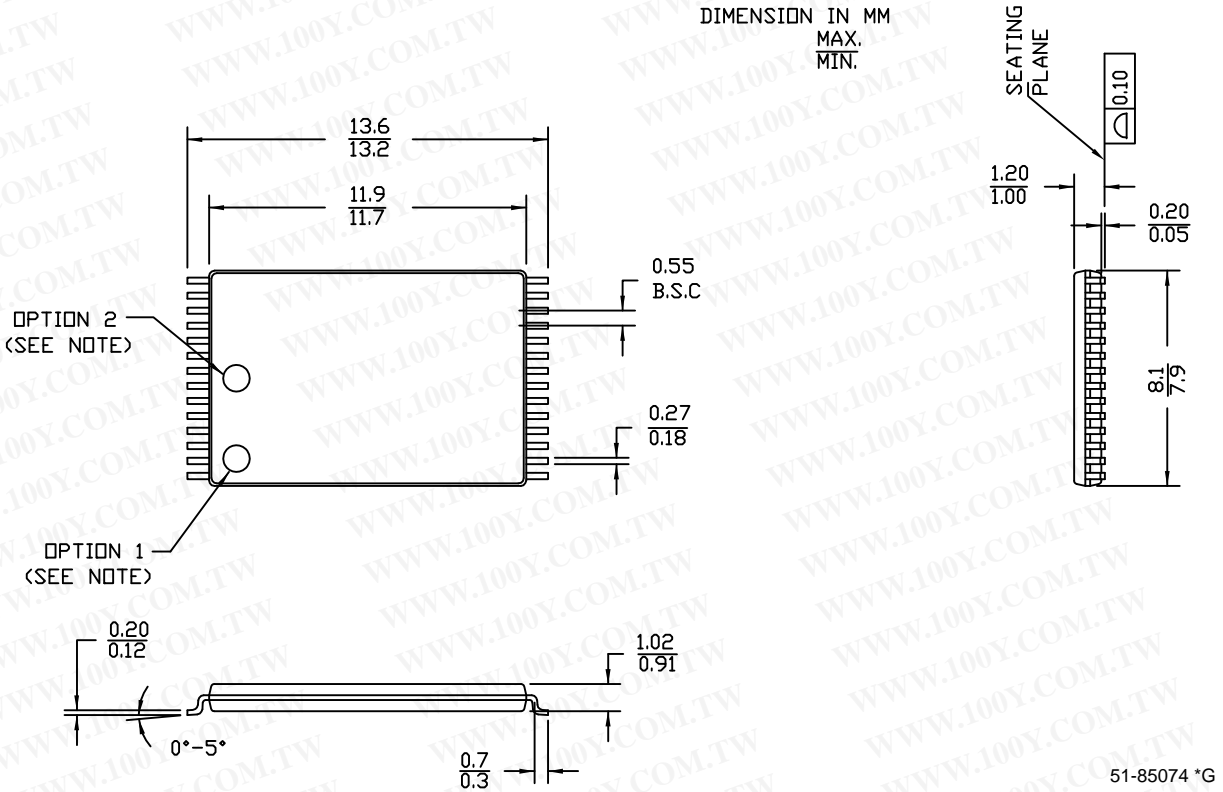

Figure 13. 28-pin TSOP I (8 × 13.4 mm), 51-85074

NOTE: ORIENTATION I.D MAY BE LOCATED EITHER AS SHOWN IN OPTION 1 OR OPTION 2



Reference Information

Acronyms

Acronym	Description
CMOS	complementary metal oxide semiconductor
I/O	input/output
SRAM	static random access memory
VFBGA	very fine ball grid array
TSOP	thin small outline package

Document Conventions

Units of Measure

Symbol	Unit of Measure
°C	degrees Celsius
μA	microampere
mA	milliampere
MHz	megahertz
ns	nanosecond
pF	picofarad
V	volt
Ω	ohm
W	watt

Document History Page

Document Title: CY62256N 256 K (32 K × 8) Static RAM Document Number: 001-06511				
Revision	ECN	Orig. of Change	Submission Date	Description of Change
**	426504	NXR	See ECN	New Datasheet
*A	488954	NXR	See ECN	Added Automotive product Updated ordering Information table
*B	2715270	VKN/AESA	06/05/2009	Updated POD of 28-Pin (600-Mil) Molded DIP package (Spec# 51-85017)
*C	2891344	VKN	03/12/2010	Added Table of Contents Removed "L" product information Updated Ordering Information table Updated Package Diagrams (Figure 10, Figure 11, and Figure 12) Updated Sales, Solutions, and Legal Information
*D	3119519	AJU	01/04/2011	Updated Ordering Information . Added Ordering Code Definitions .
*E	3329873	RAME	07/27/11	Updated template and styles according to current Cypress standards. Added acronyms and units. Removed reference to AN1064 SRAM system guidelines. Updated operation recovery time parameter under Data Retention Characteristics on page 5 .



勝特力材料 886-3-5753170
勝特力电子(上海) 86-21-34970699
勝特力电子(深圳) 86-755-83298787
[Http://www.100y.com.tw](http://www.100y.com.tw)

CY62256N

Sales, Solutions, and Legal Information

Worldwide Sales and Design Support

Cypress maintains a worldwide network of offices, solution centers, manufacturer's representatives, and distributors. To find the office closest to you, visit us at [Cypress Locations](#).

Products

Automotive	cypress.com/go/automotive
Clocks & Buffers	cypress.com/go/clocks
Interface	cypress.com/go/interface
Lighting & Power Control	cypress.com/go/powerpsoc
Memory	cypress.com/go/plc
Optical & Image Sensing	cypress.com/go/memory
PSoC	cypress.com/go/image
Touch Sensing	cypress.com/go/psoc
USB Controllers	cypress.com/go/touch
Wireless/RF	cypress.com/go/usb
	cypress.com/go/wireless

PSoC Solutions

psoc.cypress.com/solutions
PSoC 1 | PSoC 3 | PSoC 5

© Cypress Semiconductor Corporation, 2006-2011. The information contained herein is subject to change without notice. Cypress Semiconductor Corporation assumes no responsibility for the use of any circuitry other than circuitry embodied in a Cypress product. Nor does it convey or imply any license under patent or other rights. Cypress products are not warranted nor intended to be used for medical, life support, life saving, critical control or safety applications, unless pursuant to an express written agreement with Cypress. Furthermore, Cypress does not authorize its products for use as critical components in life-support systems where a malfunction or failure may reasonably be expected to result in significant injury to the user. The inclusion of Cypress products in life-support systems application implies that the manufacturer assumes all risk of such use and in doing so indemnifies Cypress against all charges.

Any Source Code (software and/or firmware) is owned by Cypress Semiconductor Corporation (Cypress) and is protected by and subject to worldwide patent protection (United States and foreign), United States copyright laws and international treaty provisions. Cypress hereby grants to licensee a personal, non-exclusive, non-transferable license to copy, use, modify, create derivative works of, and compile the Cypress Source Code and derivative works for the sole purpose of creating custom software and or firmware in support of licensee product to be used only in conjunction with a Cypress integrated circuit as specified in the applicable agreement. Any reproduction, modification, translation, compilation, or representation of this Source Code except as specified above is prohibited without the express written permission of Cypress.

Disclaimer: CYPRESS MAKES NO WARRANTY OF ANY KIND, EXPRESS OR IMPLIED, WITH REGARD TO THIS MATERIAL, INCLUDING, BUT NOT LIMITED TO, THE IMPLIED WARRANTIES OF MERCHANTABILITY AND FITNESS FOR A PARTICULAR PURPOSE. Cypress reserves the right to make changes without further notice to the materials described herein. Cypress does not assume any liability arising out of the application or use of any product or circuit described herein. Cypress does not authorize its products for use as critical components in life-support systems where a malfunction or failure may reasonably be expected to result in significant injury to the user. The inclusion of Cypress' product in a life-support systems application implies that the manufacturer assumes all risk of such use and in doing so indemnifies Cypress against all charges.

Use may be limited by and subject to the applicable Cypress software license agreement.