

n FEATURES

- ✓ Wide V_{CC} operation voltage : 2.4V ~ 5.5V
- ✓ Very low power consumption :
 - $V_{CC} = 3.0V$ Operation current : 25mA (Max.) at 70ns
1mA (Max.) at 1MHz
Standby current : 0.01uA(Typ.) at 25°C
 - $V_{CC} = 5.0V$ Operation current : 40mA (Max.) at 55ns
2mA (Max.) at 1MHz
Standby current : 0.4uA (Typ.) at 25°C
- ✓ High speed access time :
 - 55 55ns(Max.) at $V_{CC} : 4.5\sim 5.5V$
 - 70 70ns(Max.) at $V_{CC} : 3.0\sim 5.5V$
- ✓ Automatic power down when chip is deselected
- ✓ Easy expansion with CE and OE options
- ✓ Three state outputs and TTL compatible
- ✓ Fully static operation
- ✓ Data retention supply voltage as low as 1.5V

n DESCRIPTION

The BS62LV256 is a high performance, very low power CMOS Static Random Access Memory organized as 32,768 by 8 bits and operates from a wide range of 2.4V to 5.5V supply voltage. Advanced CMOS technology and circuit techniques provide both high speed and low power features with typical CMOS standby current of 0.01uA and maximum access time of 70ns in 3.0V operation. Easy memory expansion is provided by an active LOW chip enable (\overline{CE}), and active LOW output enable (\overline{OE}) and three-state output drivers. The BS62LV256 has an automatic power down feature, reducing the power consumption significantly when chip is deselected. The BS62LV256 is available in DICE form, JEDEC standard 28 pin 330mil Plastic SOP, 600mil Plastic DIP, 8mmx13.4mm TSOP (normal type).

勝特力材料 886-3-5753170
 勝特力电子(上海) 86-21-34970699
 勝特力电子(深圳) 86-755-83298787
[Http://www.100y.com.tw](http://www.100y.com.tw)

n POWER CONSUMPTION

PRODUCT FAMILY	OPERATING TEMPERATURE	POWER DISSIPATION								PKG TYPE
		STANDBY (I_{CCSBI} , Max)		Operating (I_{CC} , Max)						
		$V_{CC}=5.0V$	$V_{CC}=3.0V$	$V_{CC}=5.0V$			$V_{CC}=3.0V$			
				1MHz	10MHz	f_{Max}	1MHz	10MHz	f_{Max}	
BS62LV256DC	Commercial +0°C to +70°C	4.0uA	0.4uA	1.5mA	18mA	35mA	0.8mA	12mA	20mA	DICE
BS62LV256PC										PDIP-28
BS62LV256SC										SOP-28
BS62LV256TC										TSOP-28
BS62LV256PI	Industrial -40°C to +85°C	5.0uA	0.7uA	2mA	20mA	40mA	1mA	15mA	25mA	PDIP-28
BS62LV256SI										SOP-28
BS62LV256TI										TSOP-28

n PIN CONFIGURATIONS

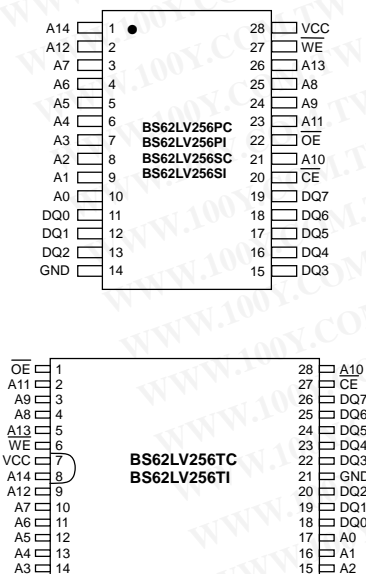

n BLOCK DIAGRAM

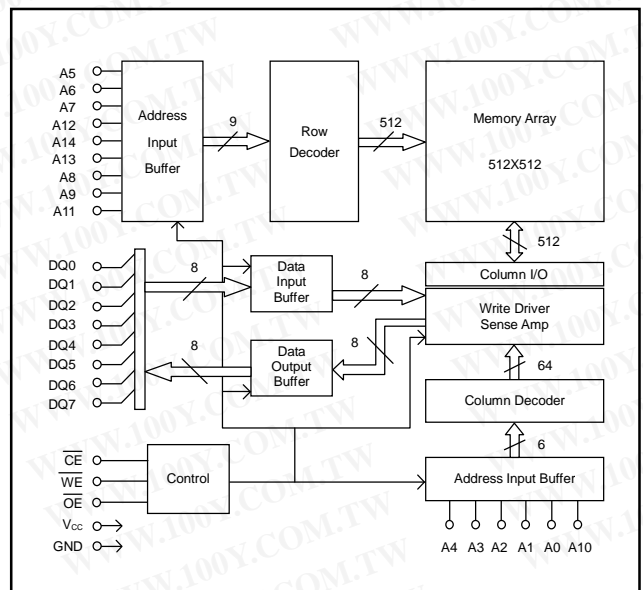

Brilliance Semiconductor, Inc. reserves the right to change products and specifications without notice.

n PIN DESCRIPTIONS

Name	Function
A0-A14 Address Input	These 15 address inputs select one of the 32,768 x 8-bit in the RAM
CE Chip Enable Input	\overline{CE} is active LOW. Chip enable must be active when data read from or write to the device. If chip enable is not active, the device is deselected and is in standby power mode. The DQ pins will be in the high impedance state when the device is deselected.
WE Write Enable Input	The write enable input is active LOW and controls read and write operations. With the chip selected, when \overline{WE} is HIGH and \overline{OE} is LOW, output data will be present on the DQ pins; when \overline{WE} is LOW, the data present on the DQ pins will be written into the selected memory location.
OE Output Enable Input	The output enable input is active LOW. If the output enable is active while the chip is selected and the write enable is inactive, data will be present on the DQ pins and they will be enabled. The DQ pins will be in the high impedance state when \overline{OE} is inactive.
DQ0-DQ7 Data Input/Output Ports	There 8 bi-directional ports are used to read data from or write data into the RAM.
V_{CC}	Power Supply
GND	Ground

勝特力材料 886-3-5753170
 勝特力电子(上海) 86-21-34970699
 勝特力电子(深圳) 86-755-83298787
[Http://www.100y.com.tw](http://www.100y.com.tw)

n TRUTH TABLE

MODE	\overline{CE}	\overline{WE}	\overline{OE}	I/O OPERATION	V _{CC} CURRENT
Not selected (Power Down)	H	X	X	High Z	I _{CCSB} , I _{CCSB1}
Output Disabled	L	H	H	High Z	I _{CC}
Read	L	H	L	D _{OUT}	I _{CC}
Write	L	L	X	D _{IN}	I _{CC}

NOTES: H means V_{IH}; L means V_{IL}; X means don't care (Must be V_{IH} or V_{IL} state)

n ABSOLUTE MAXIMUM RATINGS ⁽¹⁾

SYMBOL	PARAMETER	RATING	UNITS
V _{TERM}	Terminal Voltage with Respect to GND	-0.5 ⁽²⁾ to 7.0	V
T _{BIAS}	Temperature Under Bias	-40 to +125	°C
T _{STG}	Storage Temperature	-60 to +150	°C
P _T	Power Dissipation	1.0	W
I _{OUT}	DC Output Current	20	mA

1. Stresses greater than those listed under ABSOLUTE MAXIMUM RATINGS may cause permanent damage to the device. This is a stress rating only and functional operation of the device at these or any other conditions above those indicated in the operational sections of this specification is not implied. Exposure to absolute maximum rating conditions for extended periods may affect reliability.

2. -2.0V in case of AC pulse width less than 30 ns.

n OPERATING RANGE

RANG	AMBIENT TEMPERATURE	V _{CC}
Commercial	0°C to +70°C	2.4V ~ 5.5V
Industrial	-40°C to +85°C	2.4V ~ 5.5V

n CAPACITANCE ⁽¹⁾ (T_A = 25°C, f = 1.0MHz)

SYMBOL	PARAMETER	CONDITIONS	MAX.	UNITS
C _{IN}	Input Capacitance	V _{IN} = 0V	6	pF
C _{IO}	Input/Output Capacitance	V _{IO} = 0V	8	pF

1. This parameter is guaranteed and not 100% tested.

n DC ELECTRICAL CHARACTERISTICS (T_A = -40°C to +85°C)

PARAMETER NAME	PARAMETER	TEST CONDITIONS	MIN.	TYP. ⁽¹⁾	MAX.	UNITS	
V _{CC}	Power Supply		2.4	--	5.5	V	
V _{IL}	Input Low Voltage		-0.5 ⁽²⁾	--	0.8	V	
V _{IH}	Input High Voltage		2.2	--	V _{CC} +0.3 ⁽³⁾	V	
I _{IL}	Input Leakage Current	V _{IN} = 0V to V _{CC}	--	--	1	uA	
I _{LO}	Output Leakage Current	$\overline{CE} = V_{IH}$, or $\overline{OE} = V_{IH}$, V _{I/O} = 0V to V _{CC}	--	--	1	uA	
V _{OL}	Output Low Voltage	V _{CC} = Max, I _{OL} = 0.5mA	--	--	0.4	V	
V _{OH}	Output High Voltage	V _{CC} = Min, I _{OH} = -0.5mA	2.4	--	--	V	
I _{CC} ⁽⁵⁾	Operating Power Supply Current	$\overline{CE} = V_{IL}$, I _{DQ} = 0mA, f = F _{MAX} ⁽⁴⁾	V _{CC} =3.0V	--	--	25	mA
			V _{CC} =5.0V	--	--	40	
I _{CC1}	Operating Power Supply Current	$\overline{CE} = V_{IL}$, I _{DQ} = 0mA, f = 1MHz	V _{CC} =3.0V	--	--	1	mA
			V _{CC} =5.0V	--	--	2	
I _{CCSB}	Standby Current – TTL	$\overline{CE} = V_{IH}$, I _{DQ} = 0mA	V _{CC} =3.0V	--	--	1.0	mA
			V _{CC} =5.0V	--	--	2.0	
I _{CCSB1} ⁽⁶⁾	Standby Current – CMOS	$\overline{CE} \geq V_{CC}-0.2V$, V _{IN} $\geq V_{CC}-0.2V$ or V _{IN} $\leq 0.2V$	V _{CC} =3.0V	--	0.01	0.7	uA
			V _{CC} =5.0V	--	0.4	5.0	

1. Typical characteristics are at T_A=25°C and not 100% tested.
2. Undershoot: -1.0V in case of pulse width less than 20 ns.
3. Overshoot: V_{CC}+1.0V in case of pulse width less than 20 ns.

4. F_{MAX}=1/t_{RC}.
5. I_{CC}(MAX.) is 20mA/35mA at V_{CC}=3.0V/5.0V and T_A=70°C.
6. I_{CCSB1}(MAX.) is 0.4uA/4.0uA at V_{CC}=3.0V/5.0V and T_A=70°C.

n DATA RETENTION CHARACTERISTICS (T_A = -40°C to +85°C)

SYMBOL	PARAMETER	TEST CONDITIONS	MIN.	TYP. ⁽¹⁾	MAX.	UNITS
V _{DR}	V _{CC} for Data Retention	$\overline{CE} \geq V_{CC}-0.2V$, V _{IN} $\geq V_{CC}-0.2V$ or V _{IN} $\leq 0.2V$	1.5	--	--	V
I _{CCDR} ⁽³⁾	Data Retention Current	$\overline{CE} \geq V_{CC}-0.2V$, V _{IN} $\geq V_{CC}-0.2V$ or V _{IN} $\leq 0.2V$	--	0.01	0.7	uA
t _{CDR}	Chip Deselect to Data Retention Time	See Retention Waveform	0	--	--	ns
t _R	Operation Recovery Time		t _{RC} ⁽²⁾	--	--	ns

1. V_{CC}=1.5V, T_A=25°C and not 100% tested.
2. t_{RC} = Read Cycle Time.
3. I_{CCDR}(MAX.) is 0.4uA at T_A=70°C.

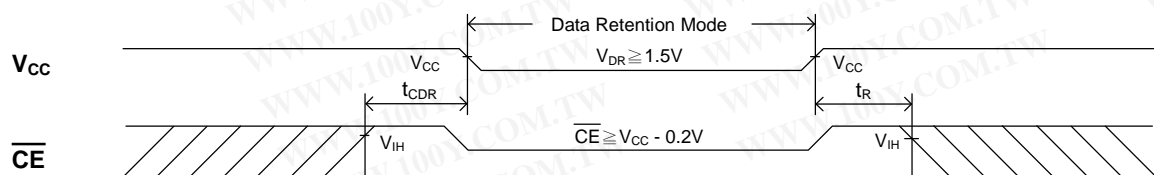
n LOW V_{CC} DATA RETENTION WAVEFORM (\overline{CE} Controlled)



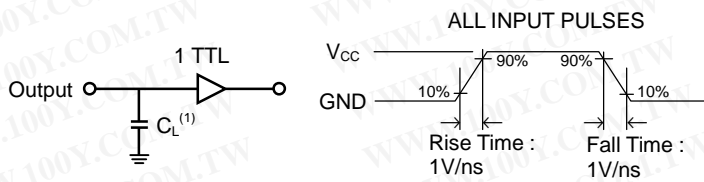

n AC TEST CONDITIONS
 (Test Load and Input/Output Reference)

Input Pulse Levels	$V_{cc} / 0V$
Input Rise and Fall Times	1V/ns
Input and Output Timing Reference Level	0.5V _{cc}
Output Load	$t_{CLZ}, t_{OLZ}, t_{CHZ}, t_{OHZ}, t_{WHZ}$
	Others
	$C_L = 5pF + 1TTL$
	$C_L = 100pF + 1TTL$

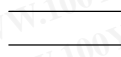

1. Including jig and scope capacitance.

n KEY TO SWITCHING WAVEFORMS

WAVEFORM	INPUTS	OUTPUTS
	MUST BE STEADY	MUST BE STEADY
	MAY CHANGE FROM "H" TO "L"	WILL BE CHANGE FROM "H" TO "L"
	MAY CHANGE FROM "L" TO "H"	WILL BE CHANGE FROM "L" TO "H"
	DON'T CARE ANY CHANGE PERMITTED	CHANGE : STATE UNKNOWN
	DOES NOT APPLY	CENTER LINE IS HIGH IMPEDANCE "OFF" STATE

n AC ELECTRICAL CHARACTERISTICS (T_A = -40°C to +85°C)
READ CYCLE

JEDEC PARAMETER NAME	PARAMETER NAME	DESCRIPTION	CYCLE TIME : 55ns (V _{cc} = 4.5~5.5V)			CYCLE TIME : 70ns (V _{cc} = 3.0~5.5V)			UNITS
			MIN.	TYP.	MAX.	MIN.	TYP.	MAX.	
t _{AVAX}	t _{RC}	Read Cycle Time	55	--	--	70	--	--	ns
t _{AVQX}	t _{AA}	Address Access Time	--	--	55	--	--	70	ns
t _{E1LQV}	t _{ACS}	Chip Select Access Time	--	--	55	--	--	70	ns
t _{GLQV}	t _{oE}	Output Enable to Output Valid	--	--	25	--	--	35	ns
t _{E1LQX}	t _{CLZ}	Chip Select to Output Low Z	10	--	--	10	--	--	ns
t _{GLQX}	t _{OLZ}	Output Enable to Output Low Z	10	--	--	10	--	--	ns
t _{E1HQZ}	t _{CHZ}	Chip Select to Output High Z	--	--	30	--	--	35	ns
t _{GHQZ}	t _{OHZ}	Output Enable to Output High Z	--	--	25	--	--	30	ns
t _{AVQX}	t _{oH}	Data Hold from Address Change	10	--	--	10	--	--	ns

勝特力材料 886-3-5753170
 勝特力电子(上海) 86-21-34970699
 勝特力电子(深圳) 86-755-83298787
[Http://www.100y.com.tw](http://www.100y.com.tw)

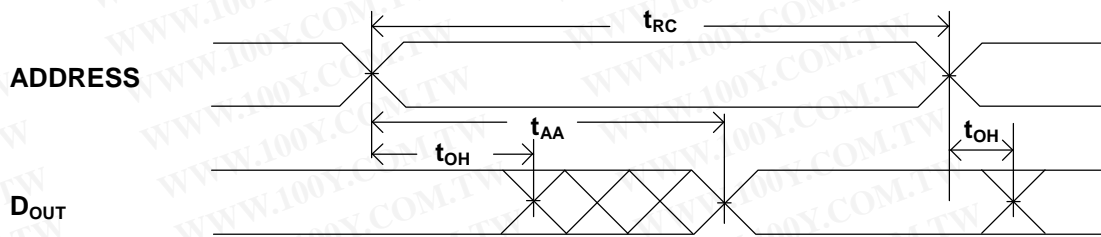
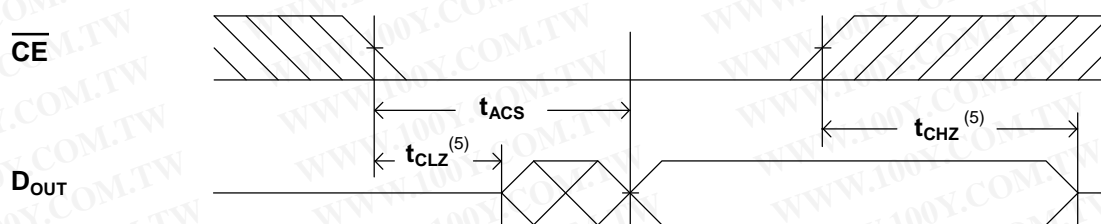
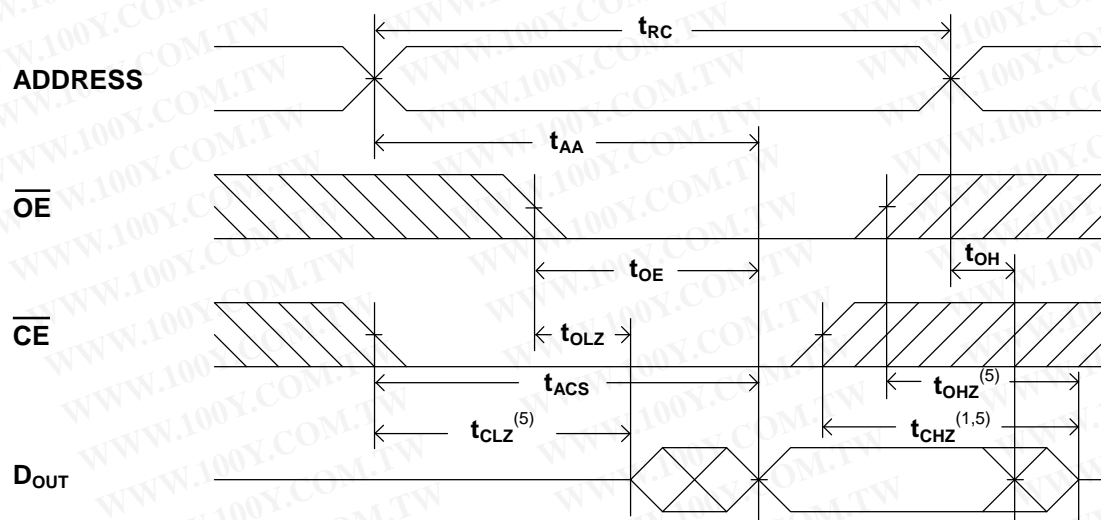
n SWITCHING WAVEFORMS (READ CYCLE)
READ CYCLE 1 (1,2,4)

READ CYCLE 2 (1,3,4)

READ CYCLE 3 (1,4)

NOTES:

1. \overline{WE} is high in read Cycle.
2. Device is continuously selected when $\overline{CE} = V_{IL}$.
3. Address valid prior to or coincident with \overline{CE} transition low.
4. $\overline{OE} = V_{IL}$.
5. Transition is measured $\pm 500\text{mV}$ from steady state with $C_L = 5\text{pF}$.
The parameter is guaranteed but not 100% tested.

勝特力材料 886-3-5753170
 勝特力电子(上海) 86-21-34970699
 勝特力电子(深圳) 86-755-83298787
[Http://www.100y.com.tw](http://www.100y.com.tw)

n AC ELECTRICAL CHARACTERISTICS (T_A = -40°C to +85°C)
WRITE CYCLE

JEDEC PARAMETER NAME	PARAMETER NAME	DESCRIPTION	CYCLE TIME : 55ns (V _{CC} = 4.5~5.5V)			CYCLE TIME : 70ns (V _{CC} = 3.0~5.5V)			UNITS
			MIN.	TYP.	MAX.	MIN.	TYP.	MAX.	
t _{AVAX}	t _{wc}	Write Cycle Time	55	--	--	70	--	--	ns
t _{AVWH}	t _{AW}	Address Valid to End of Write	55	--	--	70	--	--	ns
t _{E1LWH}	t _{cw}	Chip Select to End of Write	55	--	--	70	--	--	ns
t _{WLWH}	t _{wP}	Write Pulse Width	35	--	--	40	--	--	ns
t _{AVWL}	t _{AS}	Address Set up Time	0	--	--	0	--	--	ns
t _{WHAX}	t _{wR}	Write Recovery Time (CE, WE)	0	--	--	0	--	--	ns
t _{WLQZ}	t _{WHZ}	Write to Output High Z	--	--	25	--	--	30	ns
t _{DVWH}	t _{DW}	Data to Write Time Overlap	35	--	--	40	--	--	ns
t _{WHDX}	t _{DH}	Data Hold from Write Time	0	--	--	0	--	--	ns
t _{GHQZ}	t _{OHZ}	Output Disable to Output in High Z	--	--	25	--	--	30	ns
t _{WHQX}	t _{OW}	End of Write to Output Active	5	--	--	5	--	--	ns

n SWITCHING WAVEFORMS (WRITE CYCLE)
WRITE CYCLE 1 ⁽¹⁾

勝特力材料 886-3-5753170
勝特力电子(上海) 86-21-34970699
勝特力电子(深圳) 86-755-83298787
[Http://www.100y.com.tw](http://www.100y.com.tw)

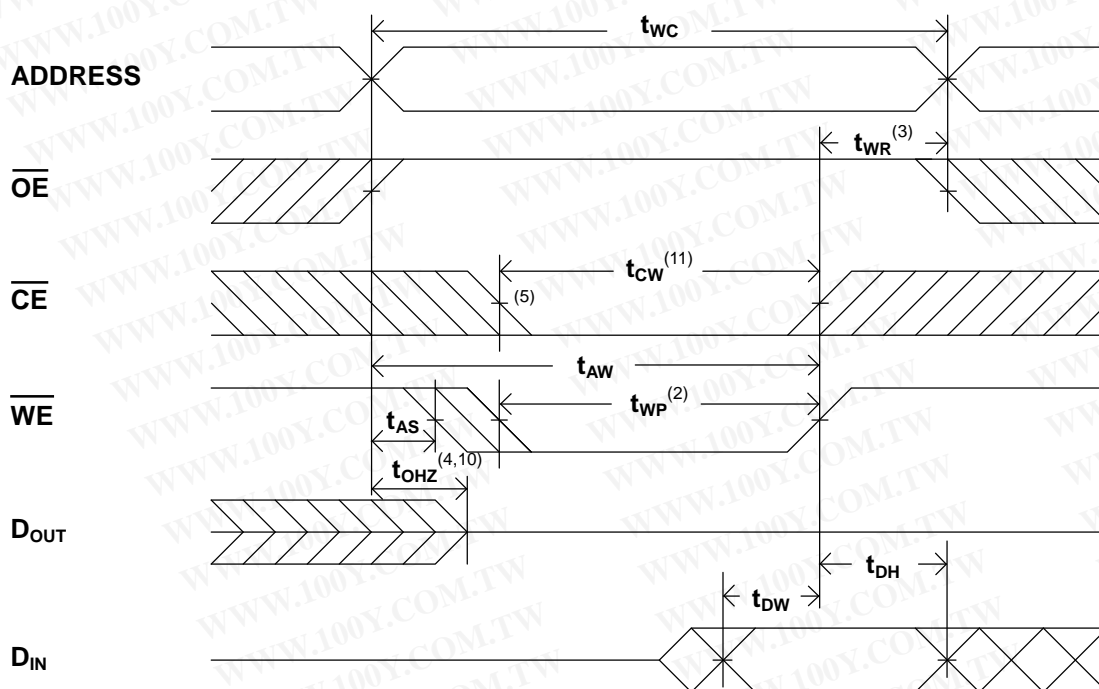

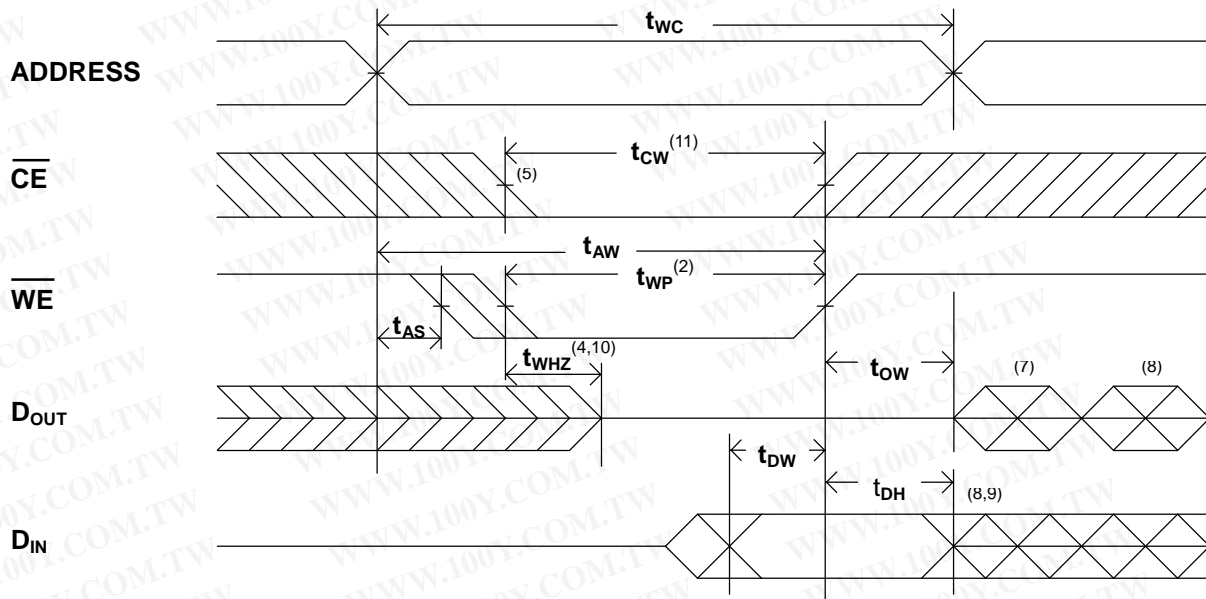
WRITE CYCLE 2 (1,6)

NOTES:

1. WE must be high during address transitions.
2. The internal write time of the memory is defined by the overlap of \overline{CE} and \overline{WE} low. All signals must be active to initiate a write and any signal can terminate a write by going inactive. The data input setup and hold timing should be referenced to the second transition edge of the signal that terminates the write.
3. t_{WR} is measured from the earlier of \overline{CE} or \overline{WE} going high at the end of write cycle.
4. During this period, DQ pins are in the output state so that the input signals of opposite phase to the outputs must not be applied.
5. If the CE low transition occurs simultaneously with the \overline{WE} low transitions or after the \overline{WE} transition, output remain in a high impedance state.
6. OE is continuously low ($OE = V_{IL}$).
7. D_{OUT} is the same phase of write data of this write cycle.
8. D_{OUT} is the read data of next address.
9. If CE is low during this period, DQ pins are in the output state. Then the data input signals of opposite phase to the outputs must not be applied to them.
10. Transition is measured $\pm 500\text{mV}$ from steady state with $C_L = 5\text{pF}$.
The parameter is guaranteed but not 100% tested.
11. t_{CW} is measured from the later of CE going low to the end of write.

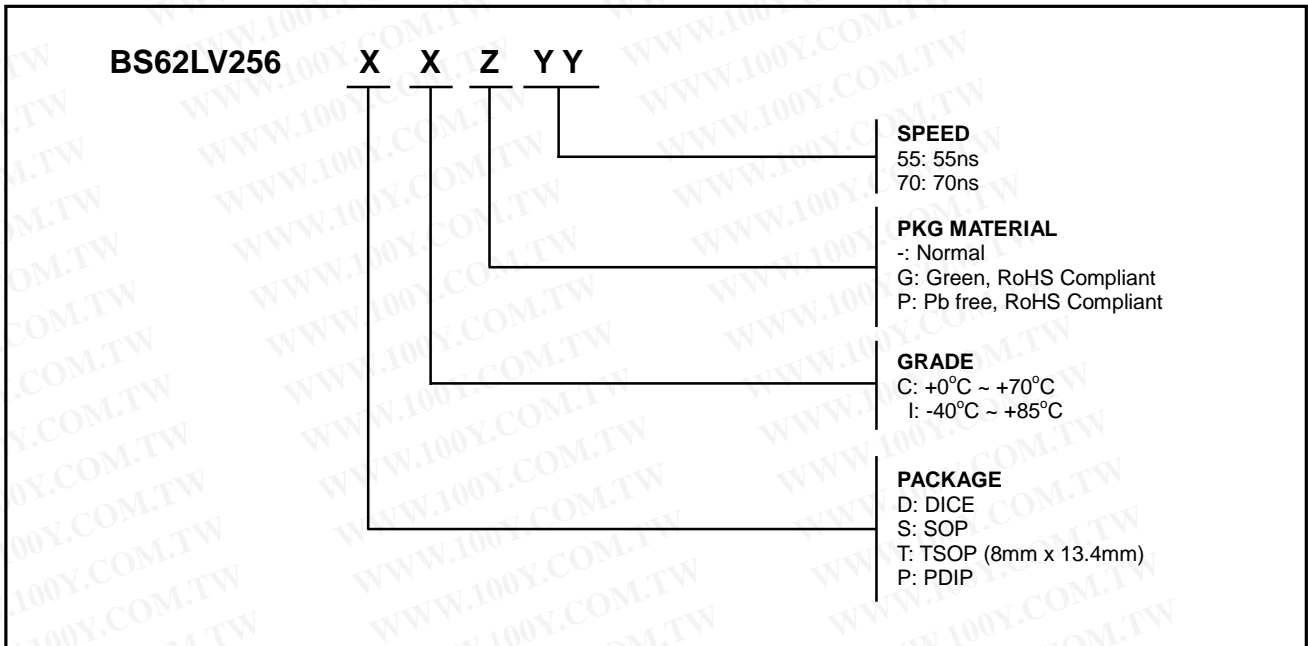
勝特力材料 886-3-5753170
 勝特力电子(上海) 86-21-34970699
 勝特力电子(深圳) 86-755-83298787
[Http://www.100y.com.tw](http://www.100y.com.tw)

n ORDERING INFORMATION

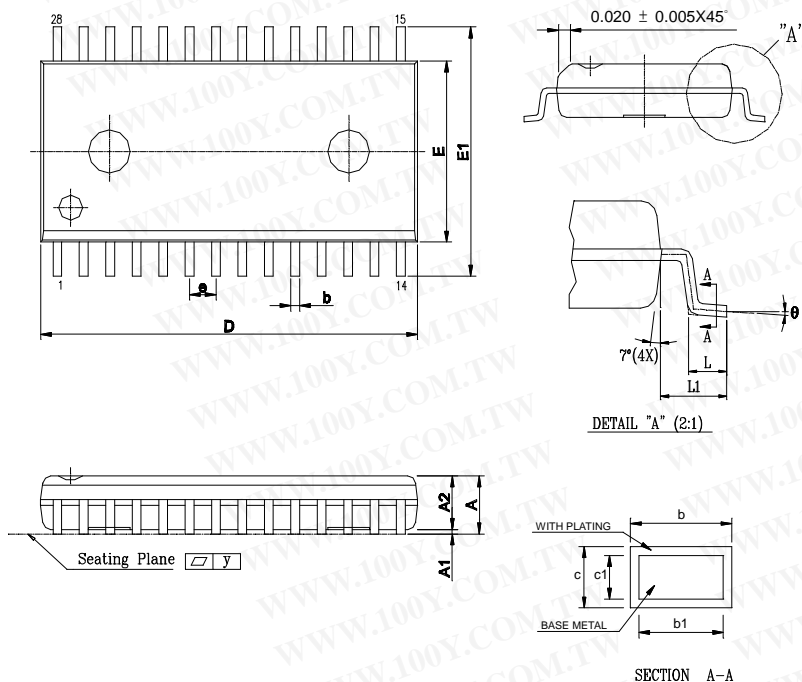
Note:

BSI (Brilliance Semiconductor Inc.) assumes no responsibility for the application or use of any product or circuit described herein. BSI does not authorize its products for use as critical components in any application in which the failure of the BSI product may be expected to result in significant injury or death, including life-support systems and critical medical instruments.

n PACKAGE DIMENSIONS

SYMBOL	UNIT	INCH	MM
A		0.106±0.006	2.692±0.152
A1		0.009±0.005	0.226±0.124
A2		0.098±0.005	2.489±0.127
b		0.014 ~ 0.020	0.35 ~ 0.50
b1		0.014 ~ 0.018	0.35 ~ 0.45
c		0.008 ~ 0.012	0.20 ~ 0.32
c1		0.008 ~ 0.011	0.20 ~ 0.28
D		0.713±0.005	18.110±0.127
E		0.331±0.005	8.407±0.127
E1		0.465±0.012	11.811±0.305
e		0.050±0.006	1.270±0.152
L		0.0380±0.0104	0.964±0.264
L1		0.0677±0.0079	1.72±0.2
y		0.004 Max.	0.1 Max.
θ		0° ~ 10°	0° ~ 10°

勝特力材料 886-3-5753170
 勝特力电子(上海) 86-21-34970699
 勝特力电子(深圳) 86-755-83298787
[Http://www.100y.com.tw](http://www.100y.com.tw)

SOP - 28

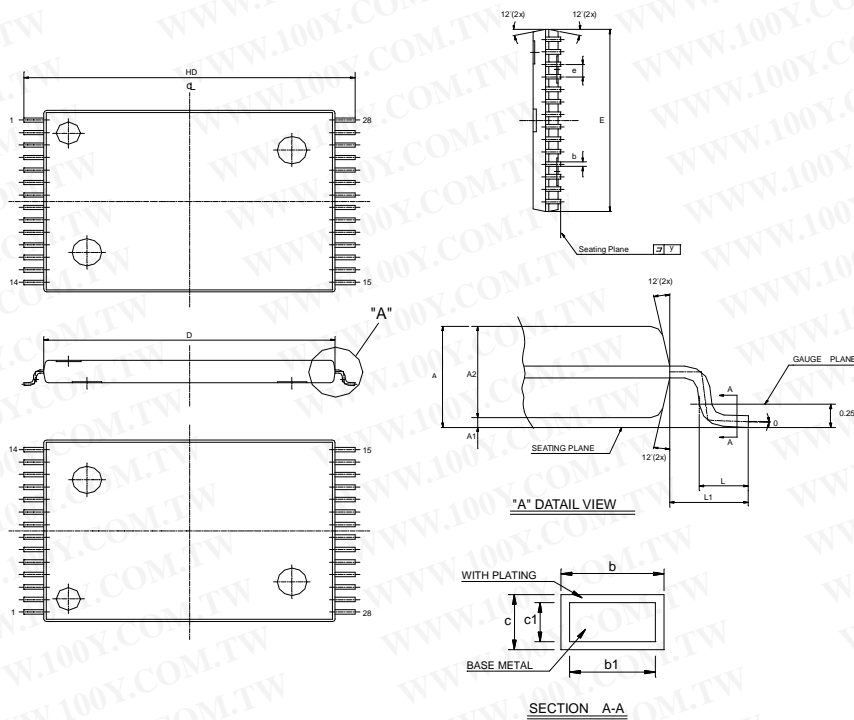
n PACKAGE DIMENSIONS (continued)

UNIT SYMBOL	INCH	MM
A	0.0433±0.004	1.10±0.10
A1	0.0045±0.0026	0.115±0.065
A2	0.039±0.002	1.00±0.05
b	0.009±0.002	0.22±0.05
b1	0.008±0.001	0.20±0.03
c	0.004 ~ 0.008	0.10 ~ 0.21
c1	0.004 ~ 0.006	0.10 ~ 0.16
D	0.465±0.004	11.80±0.10
E	0.315±0.004	8.00±0.10
e	0.022±0.004	0.55±0.10
HD	0.528±0.008	13.40±0.20
L	0.0197 ^{+0.008} / _{-0.004}	0.50 ^{+0.20} / _{-0.10}
L1	0.0315±0.004	0.80±0.10
y	0.004 Max.	0.1 Max.
θ	0° ~ 8°	0° ~ 8°

勝特力材料 886-3-5753170
勝特力电子(上海) 86-21-34970699
勝特力电子(深圳) 86-755-83298787
[Http://www.100y.com.tw](http://www.100y.com.tw)

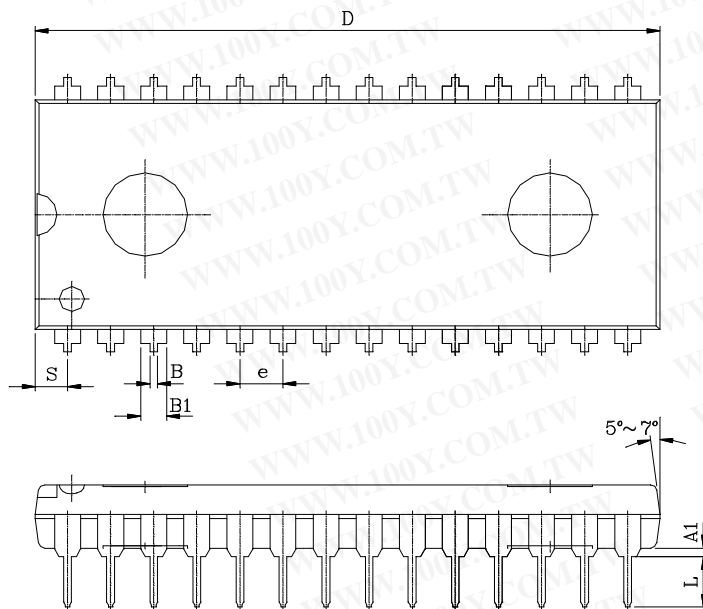
TSOP - 28

UNIT SYMBOL	INCH(BASE)	MM(REF)
A1	0.010(MIN)	0.254(MIN)
A2	0.150±0.005	3.810±0.127
B	0.018±0.005	0.457±0.127
B1	0.060±0.010	1.524±0.254
c	0.010±0.004	0.254±0.102
D	1.460±0.005	37.084±0.127
E	0.600±0.010	15.240±0.254
E1	0.544±0.004	13.818±0.102
e	0.100(TYP)	2.540(TYP)
eB	0.640±0.020	16.256±0.508
L	0.130±0.010	3.302±0.254
S	0.080±0.010	2.032±0.254
Q1	0.070±0.005	1.778±0.127
θ	6°±3°	6°±3°

PDIP - 28

n Revision History

<u>Revision No.</u>	<u>History</u>	<u>Draft Date</u>	<u>Remark</u>
2.4	Add I _{CC1} characteristic parameter	Jan. 13, 2006	
2.5	Change I-grade operation temperature range - from -25°C to -40°C	May. 25, 2006	
2.6	Revised I _{CCSB1} sepc. - from 1.0uA to 4.0uA for 5V C-grade - from 2.0uA to 5.0uA for 5V I-grade - from 0.2uA to 0.4uA for 3V C-grade - from 0.4uA to 0.7uA for 3V I-grade Revised I _{CCDR} sepc. - from 0.2uA to 0.4uA for C-grade - from 0.4uA to 0.7uA for I-grade	Sep. 05, 2006	

勝特力材料 886-3-5753170
勝特力电子(上海) 86-21-34970699
勝特力电子(深圳) 86-755-83298787
[Http://www.100y.com.tw](http://www.100y.com.tw)