

74HC237D

勝特力材料 886-3-5753170
 勝特力电子(上海) 86-21-34970699
 勝特力电子(深圳) 86-755-83298787
[Http://www.100y.com.tw](http://www.100y.com.tw)

1. Functional Description

- 3-to-8 Line Decoder/Latch

2. General

The 74HC237D is a high speed CMOS 3-to-8 DECODER ADDRESS LATCH fabricated with silicon gate C²MOS technology.

It achieves the high speed operation similar to equivalent LSTTL while maintaining the CMOS low power dissipation.

It is composed of a 3-bit input latches with a common \overline{GL} enable input and 3-to-8 line decoder with enable inputs G1 and $\overline{G2}$. The 3-bit binary data is stored into the input latch on the high level of \overline{GL} . The value of this data determines which one of the outputs will go low.

When the enable input G1 is held low or $\overline{G2}$ is held high, decoding function is inhibited and all the 8 outputs go high. The two enable inputs are provided to ease cascade connection and permits the application address decoder for memory system.

All inputs are equipped with protection circuits against static discharge or transient excess voltage.

3. Features

- (1) High speed: $t_{pd} = 12 \text{ ns (typ.)}$ at $V_{CC} = 5 \text{ V}$
- (2) Low power dissipation: $I_{CC} = 4.0 \text{ }\mu\text{A (max)}$ at $T_a = 25 \text{ }^\circ\text{C}$
- (3) Balanced propagation delays: $t_{PLH} \approx t_{PHL}$
- (4) Wide operating voltage range: $V_{CC(opr)} = 2.0 \text{ V to } 6.0 \text{ V}$

4. Packaging

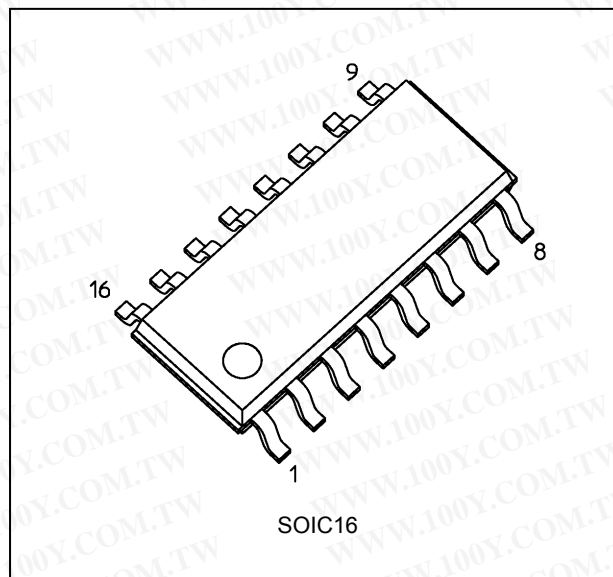

Start of commercial production

2016-05

5. Pin Assignment

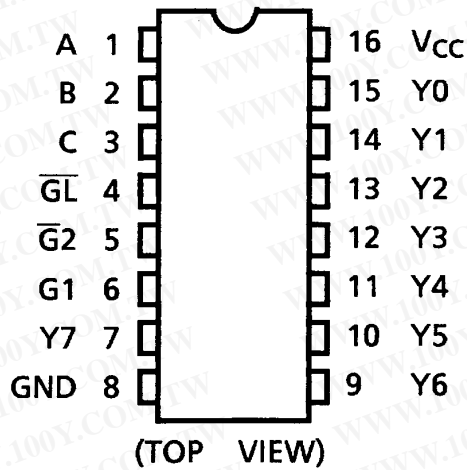

6. Marking

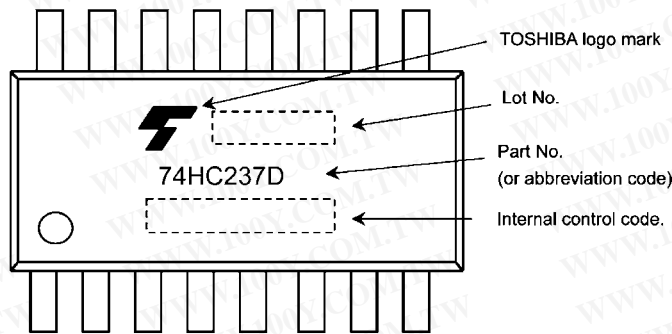

7. IEC Logic Symbol



8. Truth Table

Inputs						Outputs							
Enable			Address			Y0	Y1	Y2	Y3	Y4	Y5	Y6	Y7
\overline{GL}	$\overline{G2}$	G1	C	B	A								
X	X	L	X	X	X	L	L	L	L	L	L	L	L
X	H	X	X	X	X	L	L	L	L	L	L	L	L
L	L	H	L	L	L	H	L	L	L	L	L	L	L
L	L	H	L	L	H	L	H	L	L	L	L	L	L
L	L	H	L	H	L	L	L	H	L	L	L	L	L
L	L	H	L	H	H	L	L	L	H	L	L	L	L
L	L	H	H	L	L	L	L	L	L	H	L	L	L
L	L	H	H	L	H	L	L	L	L	L	H	L	L
L	L	H	H	H	L	L	L	L	L	L	L	H	L
L	L	H	H	H	H	L	L	L	L	L	L	L	H
H	L	H	X	X	X	Depends upon the address previously applied while \overline{GL} was at a low level							

X: Don't care

9. Logic Diagram

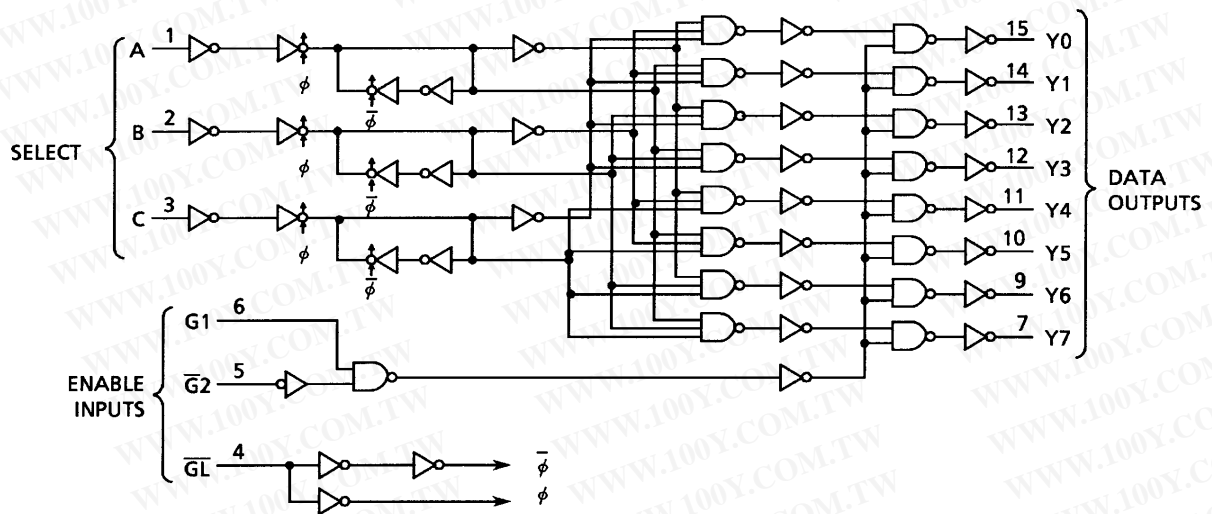

10. Absolute Maximum Ratings (Note)

Characteristics	Symbol	Note	Rating	Unit
Supply voltage	V_{CC}		-0.5 to 7.0	V
Input voltage	V_{IN}		-0.5 to $V_{CC} + 0.5$	
Output voltage	V_{OUT}		-0.5 to $V_{CC} + 0.5$	
Input diode current	I_{IK}		± 20	mA
Output diode current	I_{OK}		± 20	
Output current	I_{OUT}		± 25	
V_{CC} /ground current	I_{CC}		± 50	
Power dissipation	P_D	(Note 1)	500	mW
Storage temperature	T_{stg}		-65 to 150	$^{\circ}\text{C}$

Note: Exceeding any of the absolute maximum ratings, even briefly, lead to deterioration in IC performance or even destruction.

Using continuously under heavy loads (e.g. the application of high temperature/current/voltage and the significant change in temperature, etc.) may cause this product to decrease in the reliability significantly even if the operating conditions (i.e. operating temperature/current/voltage, etc.) are within the absolute maximum ratings and the operating ranges.

Please design the appropriate reliability upon reviewing the Toshiba Semiconductor Reliability Handbook ("Handling Precautions"/"Derating Concept and Methods") and individual reliability data (i.e. reliability test report and estimated failure rate, etc).

Note 1: P_D derates linearly with $-8 \text{ mW}/^{\circ}\text{C}$ above 85°C

11. Operating Ranges (Note)

Characteristics	Symbol	Test Condition	Rating	Unit
Supply voltage	V_{CC}	—	2.0 to 6.0	V
Input voltage	V_{IN}	—	0 to V_{CC}	V
Output voltage	V_{OUT}	—	0 to V_{CC}	V
Operating temperature	T_{opr}	—	-40 to 125	$^{\circ}\text{C}$
Input rise and fall times	t_r, t_f	—	0 to 50	μs

Note: The operating ranges are required to ensure the normal operation of the device. Unused inputs must be tied to either V_{CC} or GND.

12. Electrical Characteristics

12.1. DC Characteristics (Unless otherwise specified, $T_a = 25\text{ }^\circ\text{C}$)

Characteristics	Symbol	Test Condition	V_{CC} (V)	Min	Typ.	Max	Unit	
High-level input voltage	V_{IH}	—	2.0	1.50	—	—	V	
			4.5	3.15	—	—		
			6.0	4.20	—	—		
Low-level input voltage	V_{IL}	—	2.0	—	—	0.50	V	
			4.5	—	—	1.35		
			6.0	—	—	1.80		
High-level output voltage	V_{OH}	$V_{IN} = V_{IH}$ or V_{IL}	$I_{OH} = -20\text{ }\mu\text{A}$	2.0	1.9	2.0	—	V
				4.5	4.4	4.5	—	
			$I_{OH} = -4\text{ mA}$	4.5	4.18	4.31	—	
				6.0	5.68	5.80	—	
Low-level output voltage	V_{OL}	$V_{IN} = V_{IH}$ or V_{IL}	$I_{OL} = 20\text{ }\mu\text{A}$	2.0	—	0.0	0.1	V
				4.5	—	0.0	0.1	
				6.0	—	0.0	0.1	
			$I_{OL} = 4\text{ mA}$	4.5	—	0.17	0.26	
				6.0	—	0.18	0.26	
Input leakage current	I_{IN}	$V_{IN} = V_{CC}$ or GND	6.0	—	—	± 0.1	μA	
Quiescent supply current	I_{CC}	$V_{IN} = V_{CC}$ or GND	6.0	—	—	4.0	μA	

12.2. DC Characteristics (Unless otherwise specified, $T_a = -40$ to $85\text{ }^\circ\text{C}$)

Characteristics	Symbol	Test Condition	V_{CC} (V)	Min	Max	Unit	
High-level input voltage	V_{IH}	—	2.0	1.50	—	V	
			4.5	3.15	—		
			6.0	4.20	—		
Low-level input voltage	V_{IL}	—	2.0	—	0.50	V	
			4.5	—	1.35		
			6.0	—	1.80		
High-level output voltage	V_{OH}	$V_{IN} = V_{IH}$ or V_{IL}	$I_{OH} = -20\text{ }\mu\text{A}$	2.0	1.9	—	V
				4.5	4.4	—	
			$I_{OH} = -4\text{ mA}$	4.5	4.13	—	
				6.0	5.63	—	
Low-level output voltage	V_{OL}	$V_{IN} = V_{IH}$ or V_{IL}	$I_{OL} = 20\text{ }\mu\text{A}$	2.0	—	0.1	V
				4.5	—	0.1	
				6.0	—	0.1	
			$I_{OL} = 4\text{ mA}$	4.5	—	0.33	
				6.0	—	0.33	
Input leakage current	I_{IN}	$V_{IN} = V_{CC}$ or GND	6.0	—	± 1.0	μA	
Quiescent supply current	I_{CC}	$V_{IN} = V_{CC}$ or GND	6.0	—	40.0	μA	

12.3. DC Characteristics (Unless otherwise specified, $T_a = -40$ to 125 °C)

Characteristics	Symbol	Test Condition	V_{CC} (V)	Min	Max	Unit	
High-level input voltage	V_{IH}	—	2.0	1.50	—	V	
			4.5	3.15	—		
			6.0	4.20	—		
Low-level input voltage	V_{IL}	—	2.0	—	0.50	V	
			4.5	—	1.35		
			6.0	—	1.80		
High-level output voltage	V_{OH}	$V_{IN} = V_{IH}$ or V_{IL}	$I_{OH} = -20$ μ A	2.0	1.9	—	V
				4.5	4.4	—	
			$I_{OH} = -4$ mA	4.5	3.7	—	
				6.0	5.2	—	
Low-level output voltage	V_{OL}	$V_{IN} = V_{IH}$ or V_{IL}	$I_{OL} = 20$ μ A	2.0	—	0.1	V
				4.5	—	0.1	
				6.0	—	0.1	
			$I_{OL} = 4$ mA	4.5	—	0.4	
				6.0	—	0.4	
Input leakage current	I_{IN}	$V_{IN} = V_{CC}$ or GND	6.0	—	± 1.0	μ A	
Quiescent supply current	I_{CC}	$V_{IN} = V_{CC}$ or GND	6.0	—	160.0	μ A	

13. Timing Requirements (Unless otherwise specified, $T_a = 25$ °C, Input: $t_r = t_f = 6$ ns)

Characteristics	Symbol	Test Condition	V_{CC} (V)	Typ.	Limit	Unit
Minimum pulse width (GL)	$t_{w(L)}$	—	2.0	—	75	ns
			4.5	—	15	
			6.0	—	13	
Minimum setup time (A, B, C - GL)	t_s	—	2.0	—	50	ns
			4.5	—	10	
			6.0	—	9	
Minimum hold time (A, B, C - GL)	t_h	—	2.0	—	25	ns
			4.5	—	5	
			6.0	—	5	

14. Timing Requirements (Unless otherwise specified, $T_a = -40$ to 85 °C, Input: $t_r = t_f = 6$ ns)

Characteristics	Symbol	Test Condition	V_{CC} (V)	Limit	Unit
Minimum pulse width (GL)	$t_{w(L)}$	—	2.0	95	ns
			4.5	19	
			6.0	16	
Minimum setup time (A, B, C - GL)	t_s	—	2.0	65	ns
			4.5	13	
			6.0	11	
Minimum hold time (A, B, C - GL)	t_h	—	2.0	30	ns
			4.5	6	
			6.0	5	

15. Timing Requirements
(Unless otherwise specified, $T_a = -40$ to 125 °C, Input: $t_r = t_f = 6$ ns)

Characteristics	Symbol	Test Condition	V_{CC} (V)	Limit	Unit
Minimum pulse width (GL)	$t_{w(L)}$	—	2.0	115	ns
			4.5	23	
			6.0	20	
Minimum setup time (A, B, C - GL)	t_s	—	2.0	75	ns
			4.5	15	
			6.0	13	
Minimum hold time (A, B, C - GL)	t_h	—	2.0	40	ns
			4.5	8	
			6.0	7	

15.1. AC Characteristics
(Unless otherwise specified, $C_L = 15$ pF, $V_{CC} = 5$ V, $T_a = 25$ °C, Input: $t_r = t_f = 6$ ns)

Characteristics	Symbol	Test Condition	Min	Typ.	Max	Unit
Output transition time	t_{TLH}, t_{THL}	—	—	4	8	ns
Propagation delay time (G1 - Y)	t_{PLH}, t_{PHL}	—	—	12	24	ns
Propagation delay time (G2 - Y)	t_{PLH}, t_{PHL}	—	—	12	24	ns
Propagation delay time (GL - Y)	t_{PLH}, t_{PHL}	—	—	17	33	ns
Propagation delay time (A, B, C - Y)	t_{PLH}, t_{PHL}	—	—	15	31	ns

15.2. AC Characteristics
(Unless otherwise specified, $C_L = 50$ pF, $T_a = 25$ °C, Input: $t_r = t_f = 6$ ns)

Characteristics	Symbol	Note	V_{CC} (V)	Min	Typ.	Max	Unit
Output transition time	t_{TLH}, t_{THL}		2.0	—	30	75	ns
			4.5	—	8	15	
			6.0	—	7	13	
Propagation delay time (G1 - Y)	t_{PLH}, t_{PHL}		2.0	—	45	140	ns
			4.5	—	15	28	
			6.0	—	13	24	
Propagation delay time (G2 - Y)	t_{PLH}, t_{PHL}		2.0	—	45	140	ns
			4.5	—	15	28	
			6.0	—	13	24	
Propagation delay time (GL - Y)	t_{PLH}, t_{PHL}		2.0	—	65	190	ns
			4.5	—	21	38	
			6.0	—	18	32	
Propagation delay time (A, B, C - Y)	t_{PLH}, t_{PHL}		2.0	—	60	180	ns
			4.5	—	19	36	
			6.0	—	16	31	
Input capacitance	C_{IN}		—	—	3	—	pF
Power dissipation capacitance	C_{PD}	(Note 1)	—	—	17	—	pF

Note 1: C_{PD} is defined as the value of the internal equivalent capacitance which is calculated from the operating current consumption without load. Average operating current can be obtained by the equation.

$$I_{CC(opr)} = C_{PD} \times V_{CC} \times f_{IN} + I_{CC}$$

15.3. AC Characteristics

(Unless otherwise specified, $C_L = 50 \text{ pF}$, $T_a = -40 \text{ to } 85 \text{ }^\circ\text{C}$, Input: $t_r = t_f = 6 \text{ ns}$)

Characteristics	Symbol	V_{CC} (V)	Min	Max	Unit
Output transition time	t_{TLH}, t_{THL}	2.0	—	95	ns
		4.5	—	19	
		6.0	—	16	
Propagation delay time (G1 - Y)	t_{PLH}, t_{PHL}	2.0	—	175	ns
		4.5	—	35	
		6.0	—	30	
Propagation delay time ($\overline{G2}$ - Y)	t_{PLH}, t_{PHL}	2.0	—	175	ns
		4.5	—	35	
		6.0	—	30	
Propagation delay time (GL - Y)	t_{PLH}, t_{PHL}	2.0	—	240	ns
		4.5	—	48	
		6.0	—	41	
Propagation delay time (A, B, C - Y)	t_{PLH}, t_{PHL}	2.0	—	225	ns
		4.5	—	45	
		6.0	—	38	

15.4. AC Characteristics

(Unless otherwise specified, $C_L = 50 \text{ pF}$, $T_a = -40 \text{ to } 125 \text{ }^\circ\text{C}$, Input: $t_r = t_f = 6 \text{ ns}$)

Characteristics	Symbol	V_{CC} (V)	Min	Max	Unit
Output transition time	t_{TLH}, t_{THL}	2.0	—	110	ns
		4.5	—	22	
		6.0	—	19	
Propagation delay time (G1 - Y)	t_{PLH}, t_{PHL}	2.0	—	210	ns
		4.5	—	42	
		6.0	—	36	
Propagation delay time ($\overline{G2}$ - Y)	t_{PLH}, t_{PHL}	2.0	—	210	ns
		4.5	—	42	
		6.0	—	36	
Propagation delay time (GL - Y)	t_{PLH}, t_{PHL}	2.0	—	285	ns
		4.5	—	57	
		6.0	—	48	
Propagation delay time (A, B, C - Y)	t_{PLH}, t_{PHL}	2.0	—	270	ns
		4.5	—	54	
		6.0	—	46	

Package Dimensions

Unit: mm

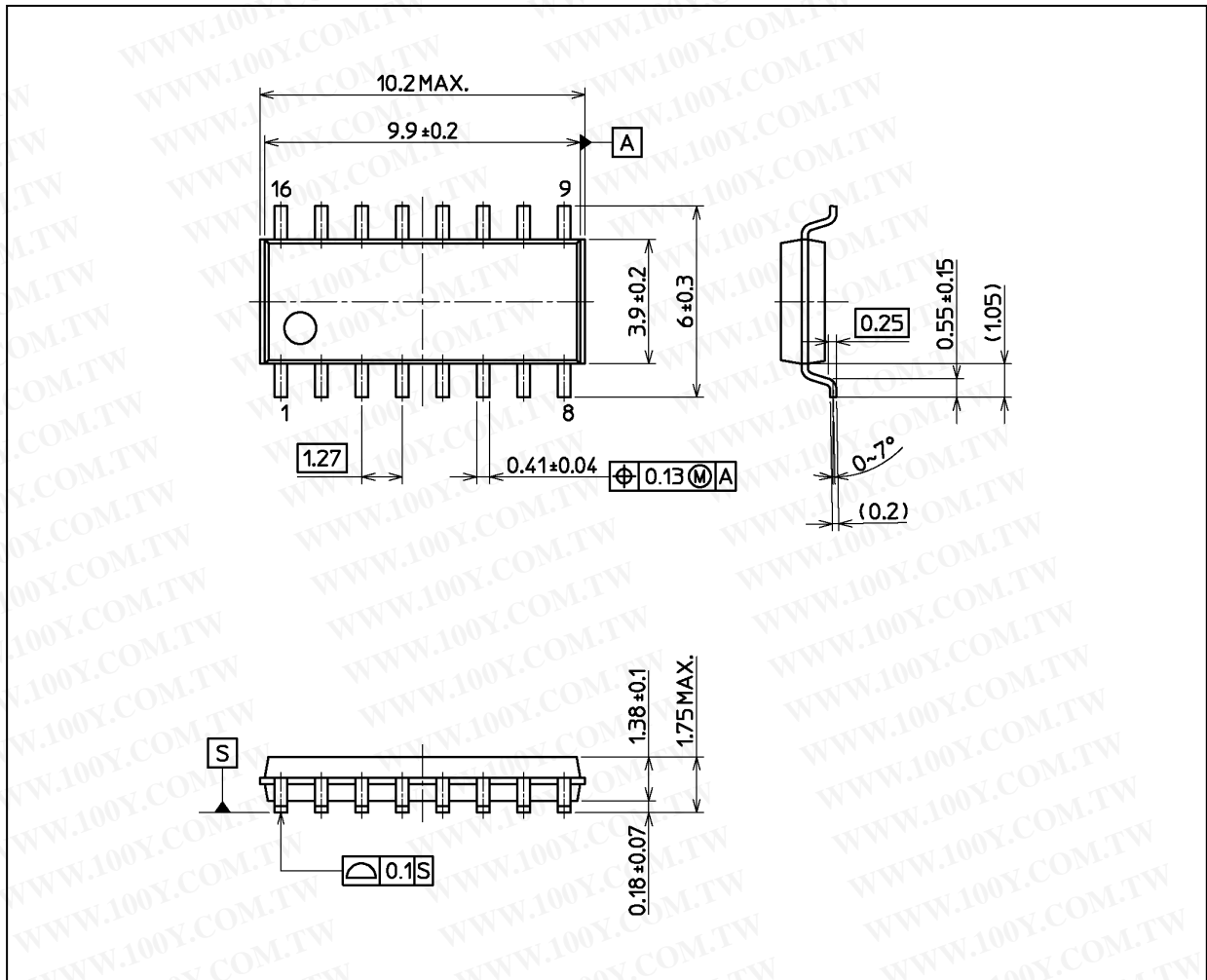

Weight: 0.15 g (typ.)

Package Name(s)
Nickname: SOIC16

勝特力材料 886-3-5753170
 勝特力电子(上海) 86-21-34970699
 勝特力电子(深圳) 86-755-83298787
[Http://www.100y.com.tw](http://www.100y.com.tw)