

SN54ALS520, SN74ALS518, SN74ALS520, SN74ALS521 8-BIT IDENTITY COMPARATORS

SDAS224B – JUNE 1982 – REVISED NOVEMBER 1995

- Compare Two 8-Bit Words
- Choice of Totem-Pole or Open-Collector Outputs
- SN74ALS518 and 'ALS520 Have 20-k Ω Pullup Resistors on Q Inputs
- Package Options Include Plastic Small-Outline (DW) Packages, Ceramic Chip Carriers (FK), and Standard Plastic (N) and Ceramic (J) 300-mil DIPs

SN54ALS520 . . . J PACKAGE
SN74ALS518, SN74ALS520,
SN74ALS521 . . . DW OR N PACKAGE
(TOP VIEW)

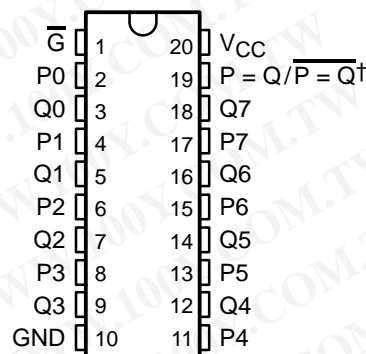

† P = Q for SN74ALS518
P = Q for 'ALS520 and SN74ALS521

TYPE	INPUT PULLUP RESISTOR	OUTPUT FUNCTION AND CONFIGURATION
SN74ALS518	Yes	P = Q open collector
'ALS520	Yes	$\overline{P = Q}$ totem pole
SN74ALS521‡	No	P = Q totem pole

‡ SN74ALS521 is identical to 'ALS688.

description

These identity comparators perform comparisons on two 8-bit binary or BCD words. The SN74ALS518 provides P = Q outputs, while the 'ALS520 and SN74ALS521 provide $\overline{P = Q}$ outputs. The SN74ALS518 has an open-collector output. The SN74ALS518 and 'ALS520 feature 20-k Ω pullup resistors on the Q inputs for analog or switch data.

The SN54ALS520 is characterized for operation over the full military temperature range of -55°C to 125°C. The SN74ALS518, SN74ALS520, and SN74ALS521 are characterized for operation from 0°C to 70°C.

SN54ALS520 . . . FK PACKAGE
(TOP VIEW)

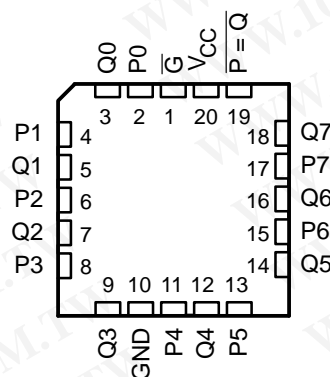

FUNCTION TABLE

INPUTS		OUTPUTS	
DATA P, Q	ENABLE \overline{G}	P = Q	$\overline{P = Q}$
P = Q	L	H	L
P > Q	L	L	H
P < Q	L	L	H
X	H	L	H

勝特力材料 886-3-5753170
勝特力电子(上海) 86-21-34970699
勝特力电子(深圳) 86-755-83298787
[Http://www.100y.com.tw](http://www.100y.com.tw)

SN54ALS520, SN74ALS518, SN74ALS520, SN74ALS521 8-BIT IDENTITY COMPARATORS

SDAS224B – JUNE 1982 – REVISED NOVEMBER 1995

logic symbols†

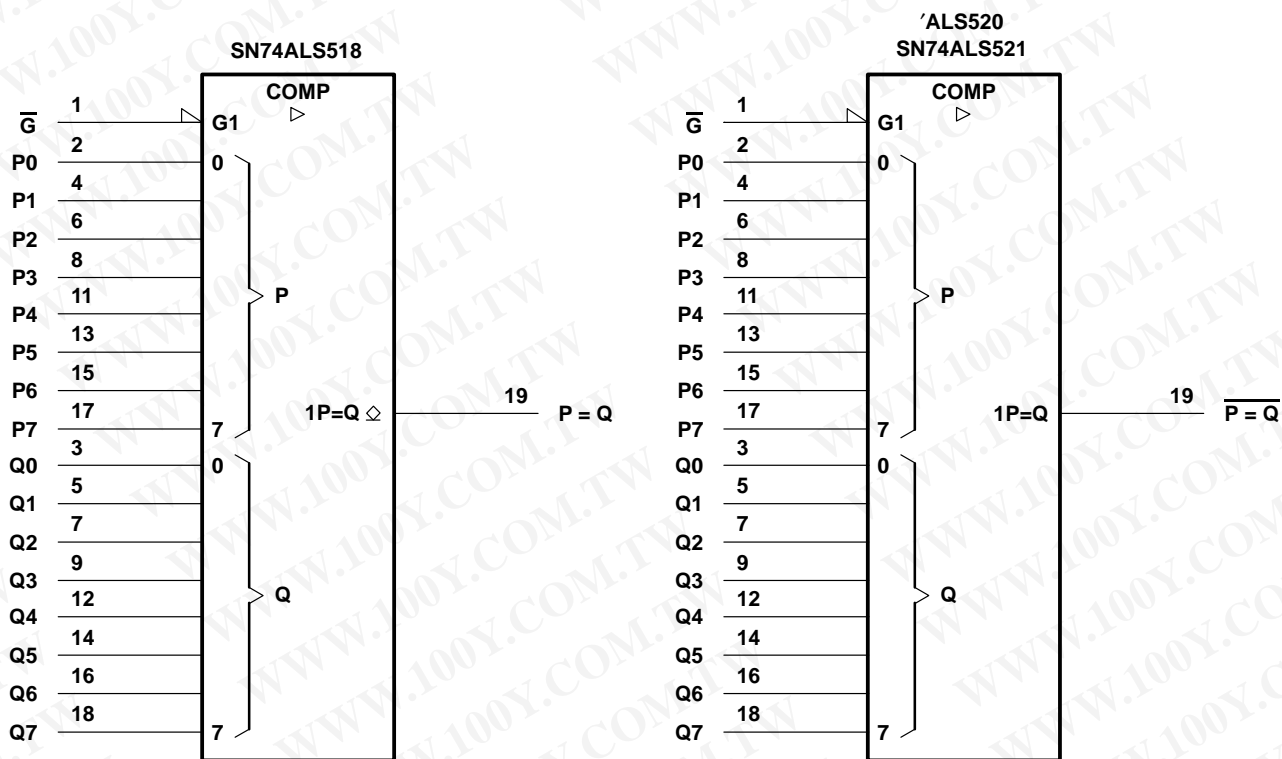

† These symbols are in accordance with ANSI/IEEE Std 91-1984 and IEC Publication 617-12.

勝特力材料 886-3-5753170
 勝特力电子(上海) 86-21-34970699
 勝特力电子(深圳) 86-755-83298787
[Http://www.100y.com.tw](http://www.100y.com.tw)

SN54ALS520, SN74ALS518, SN74ALS520, SN74ALS521 8-BIT IDENTITY COMPARATORS

SDAS224B – JUNE 1982 – REVISED NOVEMBER 1995

logic diagrams (positive logic)

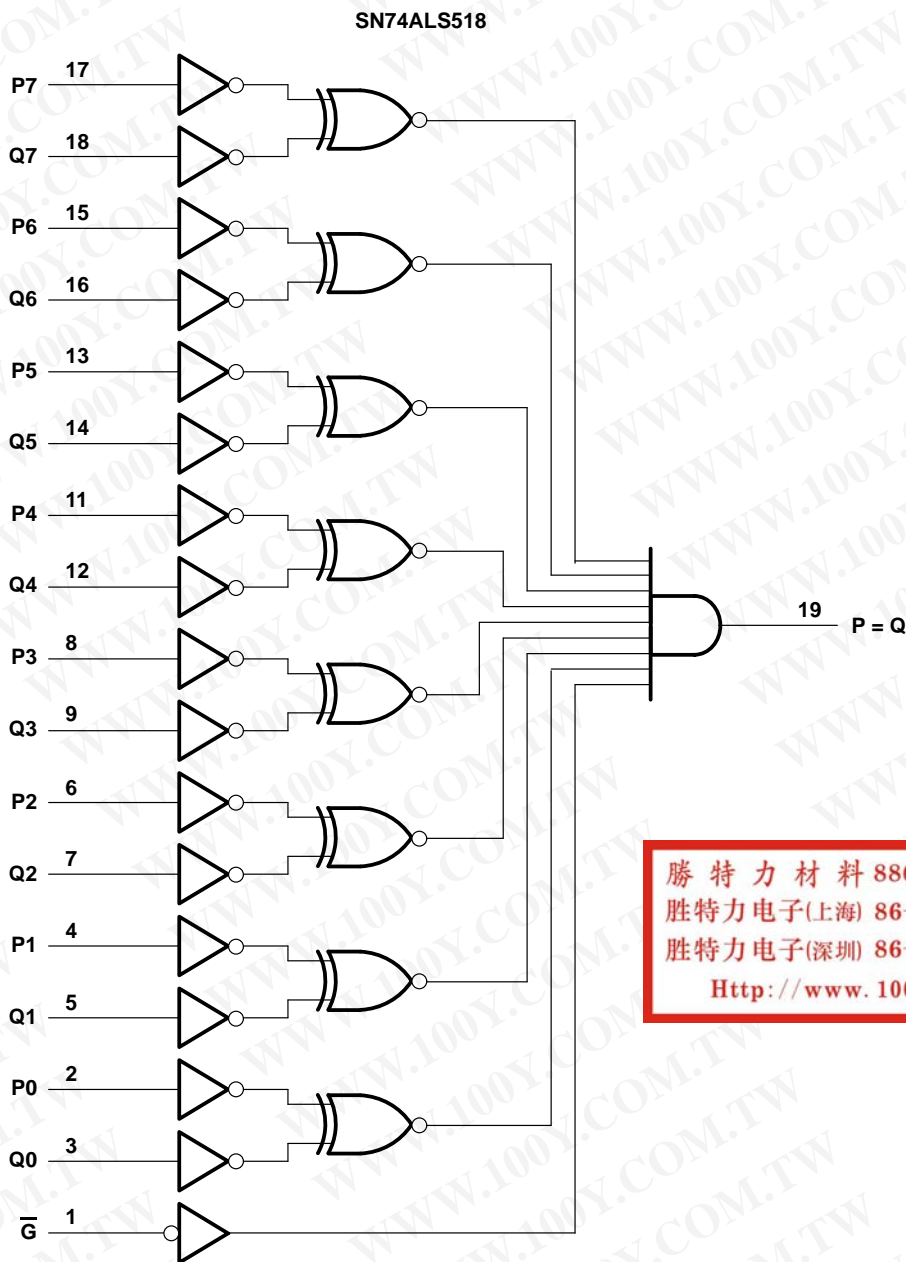

勝特力材料 886-3-5753170
勝特力电子(上海) 86-21-34970699
勝特力电子(深圳) 86-755-83298787
[Http://www.100y.com.tw](http://www.100y.com.tw)

SN54ALS520, SN74ALS518, SN74ALS520, SN74ALS521 8-BIT IDENTITY COMPARATORS

SDAS224B – JUNE 1982 – REVISED NOVEMBER 1995

logic diagrams (positive logic) (continued)

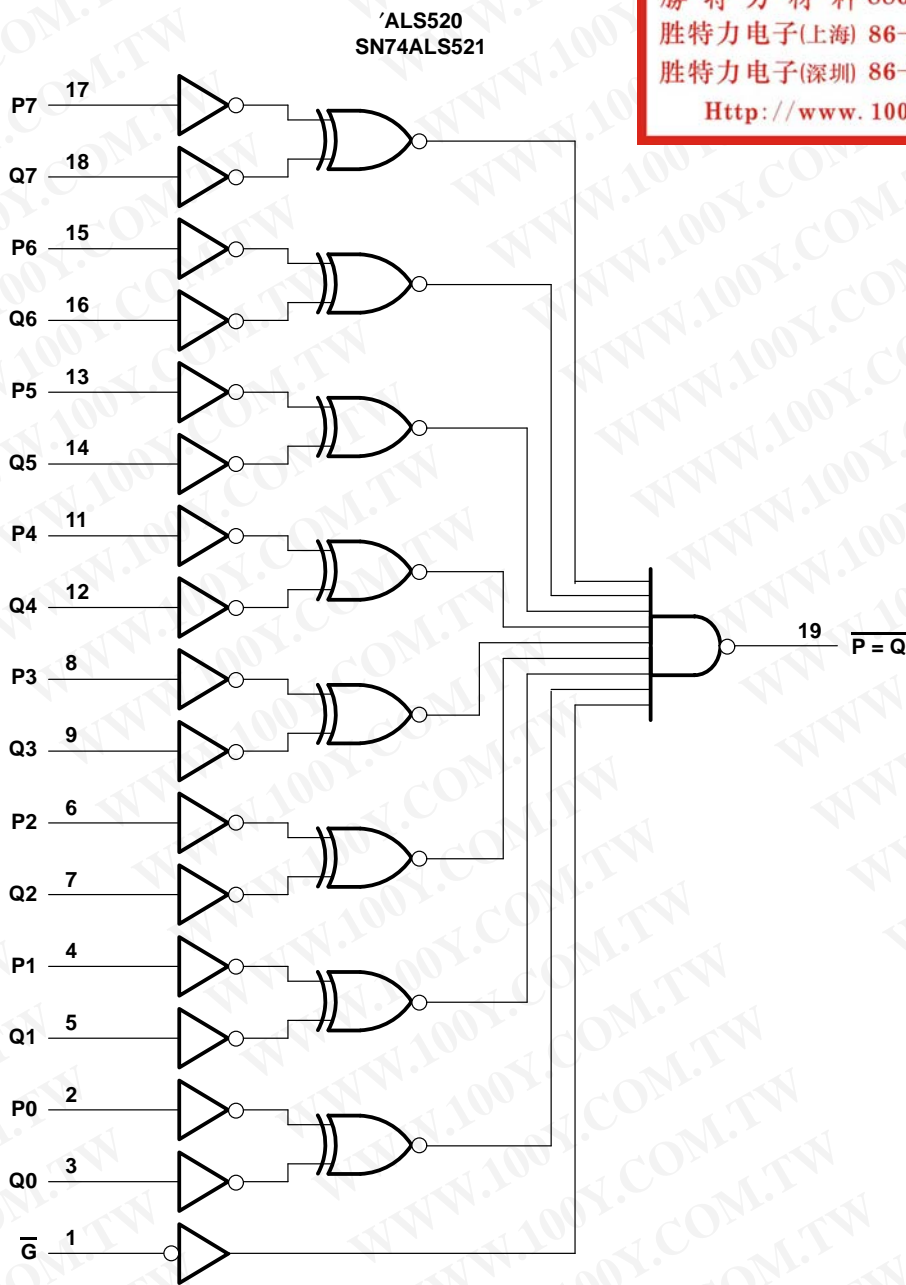

勝特力材料 886-3-5753170
勝特力电子(上海) 86-21-34970699
勝特力电子(深圳) 86-755-83298787
[Http://www.100y.com.tw](http://www.100y.com.tw)

SN54ALS520, SN74ALS518, SN74ALS520, SN74ALS521 8-BIT IDENTITY COMPARATORS

SDAS224B – JUNE 1982 – REVISED NOVEMBER 1995

absolute maximum ratings over operating free-air temperature range (unless otherwise noted)†

Supply voltage, V_{CC}	7 V
Input voltage, V_I : Q inputs	$V_{CC} + 0.5$ V or 5.5 V, whichever is less
All other inputs	7 V
Off-state output voltage	7 V
Operating free-air temperature range, T_A : SN74ALS518	0°C to 70°C
Storage temperature range	-65°C to 150°C

† Stresses beyond those listed under “absolute maximum ratings” may cause permanent damage to the device. These are stress ratings only, and functional operation of the device at these or any other conditions beyond those indicated under “recommended operating conditions” is not implied. Exposure to absolute-maximum-rated conditions for extended periods may affect device reliability.

recommended operating conditions

		SN74ALS518			UNIT
		MIN	NOM	MAX	
V_{CC}	Supply voltage	4.5	5	5.5	V
V_{IH}	High-level input voltage	2			V
V_{IL}	Low-level input voltage			0.8	V
V_{OH}	High-level output voltage			5.5	V
I_{OL}	Low-level output current			24	mA
T_A	Operating free-air temperature	0		70	°C

electrical characteristics over recommended operating free-air temperature range (unless otherwise noted)

PARAMETER	TEST CONDITIONS	SN74ALS518			UNIT
		MIN	TYP‡	MAX	
V_{IK}	$V_{CC} = 4.5$ V, $I_I = -18$ mA			-1.5	V
I_{OH}	$V_{CC} = 5.5$ V, $V_{OH} = 5.5$ V			0.1	mA
V_{OL}	$V_{CC} = 4.5$ V, $I_{OL} = 12$ mA		0.25	0.4	V
		$I_{OL} = 24$ mA	0.35	0.5	
I_I	Q inputs	$V_{CC} = 5.5$ V		0.1	mA
	All other inputs				
I_{IH}	Q inputs	$V_{CC} = 5.5$ V, $V_I = 2.7$ V		-0.2	mA
	All other inputs				
I_{IL}	Q inputs	$V_{CC} = 5.5$ V, $V_I = 0.4$ V		-0.6	mA
	All other inputs				
I_{CC}	$V_{CC} = 5.5$ V, See Note 1		11	17	mA

‡ All typical values are at $V_{CC} = 5$ V, $T_A = 25^\circ\text{C}$.

NOTE 1: I_{CC} is measured with \bar{G} grounded, and P and Q at 4.5 V.

勝特力材料 886-3-5753170
 勝特力电子(上海) 86-21-34970699
 勝特力电子(深圳) 86-755-83298787
[Http://www.100y.com.tw](http://www.100y.com.tw)



SN54ALS520, SN74ALS518, SN74ALS520, SN74ALS521

8-BIT IDENTITY COMPARATORS

SDAS224B – JUNE 1982 – REVISED NOVEMBER 1995

switching characteristics (see Figure 1)

PARAMETER	FROM (INPUT)	TO (OUTPUT)	V _{CC} = 4.5 V to 5.5 V, C _L = 50 pF, R _L = 680 Ω, T _A = MIN to MAX†		UNIT
			MIN	MAX	
t _{PLH}	P or Q	P = Q	15	33	ns
t _{PHL}			3	15	
t _{PLH}	\bar{G}	P = Q	15	33	ns
t _{PHL}			3	15	

† For conditions shown as MIN or MAX, use the appropriate value specified under recommended operating conditions.

absolute maximum ratings over operating free-air temperature range (unless otherwise noted)‡

Supply voltage, V _{CC}	7 V
Input voltage, V _I : Q inputs of 'ALS520	V _{CC} + 0.5 V or 5.5 V, whichever is less
All other inputs	7 V
Operating free-air temperature range, T _A : SN54ALS520	–55°C to 125°C
SN74ALS520, SN74ALS521	0°C to 70°C
Storage temperature range	–65°C to 150°C

‡ Stresses beyond those listed under “absolute maximum ratings” may cause permanent damage to the device. These are stress ratings only, and functional operation of the device at these or any other conditions beyond those indicated under “recommended operating conditions” is not implied. Exposure to absolute-maximum-rated conditions for extended periods may affect device reliability.

recommended operating conditions

	SN54ALS520			SN74ALS520 SN74ALS521			UNIT
	MIN	NOM	MAX	MIN	NOM	MAX	
V _{CC} Supply voltage	4.5	5	5.5	4.5	5	5.5	V
V _{IH} High-level input voltage	2			2			V
V _{IL} Low-level input voltage			0.7			0.8	V
I _{OH} High-level output current			–1			–2.6	mA
I _{OL} Low-level output current			12			24	mA
T _A Operating free-air temperature	–55		125	0		70	°C

勝特力材料 886-3-5753170
 勝特力电子(上海) 86-21-34970699
 勝特力电子(深圳) 86-755-83298787
[Http://www.100y.com.tw](http://www.100y.com.tw)



SN54ALS520, SN74ALS518, SN74ALS520, SN74ALS521 8-BIT IDENTITY COMPARATORS

SDAS224B – JUNE 1982 – REVISED NOVEMBER 1995

electrical characteristics over recommended operating free-air temperature range (unless otherwise noted)

PARAMETER		TEST CONDITIONS	SN54ALS520			SN74ALS520 SN74ALS521			UNIT
			MIN	TYP†	MAX	MIN	TYP†	MAX	
V_{IK}		$V_{CC} = 4.5\text{ V}$, $I_I = -18\text{ mA}$	-1.5			-1.5			V
V_{OH}		$V_{CC} = 4.5\text{ V to }5.5\text{ V}$, $I_{OH} = -0.4\text{ mA}$	$V_{CC} - 2$			$V_{CC} - 2$			V
		$V_{CC} = 4.5\text{ V}$ $I_{OH} = -1\text{ mA}$ $I_{OH} = -2.6\text{ mA}$	2.4	3.3		2.4	3.2		
V_{OL}		$V_{CC} = 4.5\text{ V}$	$I_{OL} = 12\text{ mA}$			0.25 0.4			V
			$I_{OL} = 24\text{ mA}$			0.35 0.5			
I_I	'ALS520 Q inputs	$V_{CC} = 5.5\text{ V}$	$V_I = 5.5\text{ V}$			0.1			mA
	All other inputs		$V_I = 7\text{ V}$			0.1			
I_{IH}	'ALS520 Q inputs	$V_{CC} = 5.5\text{ V}$, $V_I = 2.7\text{ V}$	-0.2			-0.2			mA
	All other inputs		20			20			
I_{IL}	'ALS520 Q inputs	$V_{CC} = 5.5\text{ V}$, $V_I = 0.4\text{ V}$	-0.6			-0.6			mA
	All other inputs		-0.1			-0.1			
$I_{O\ddagger}$		$V_{CC} = 5.5\text{ V}$, $V_O = 2.25\text{ V}$	-20	-112	-30	-112			mA
I_{CC}	'ALS520	$V_{CC} = 5.5\text{ V}$, See Note 1	12 19			12 19			mA
	SN74ALS521		12 19			12 19			

† All typical values are at $V_{CC} = 5\text{ V}$, $T_A = 25^\circ\text{C}$.

‡ The output conditions have been chosen to produce a current that closely approximates one half of the true short-circuit output current, I_{OS} .

NOTE 1: I_{CC} is measured with \bar{G} grounded, and P and Q at 4.5 V.

switching characteristics (see Figure 1)

PARAMETER	FROM (INPUT)	TO (OUTPUT)	$V_{CC} = 4.5\text{ V to }5.5\text{ V}$, $C_L = 50\text{ pF}$, $R_L = 500\ \Omega$, $T_A = \text{MIN to MAX}\S$				UNIT
			SN54ALS520		SN74ALS520 SN74ALS521		
			MIN	MAX	MIN	MAX	
t_{PLH}	P or Q	$\overline{P = Q}$	3	19	3	12	ns
t_{PHL}			3	25	5	20	
t_{PLH}	\bar{G}	$\overline{P = Q}$	2	18	2	12	ns
t_{PHL}			5	23	5	22	

§ For conditions shown as MIN or MAX, use the appropriate value specified under recommended operating conditions.

SN54ALS520, SN74ALS518, SN74ALS520, SN74ALS521 8-BIT IDENTITY COMPARATORS

SDAS224B – JUNE 1982 – REVISED NOVEMBER 1995

勝特力材料 886-3-5753170
 勝特力电子(上海) 86-21-34970699
 勝特力电子(深圳) 86-755-83298787
[Http://www.100y.com.tw](http://www.100y.com.tw)

PARAMETER MEASUREMENT INFORMATION SERIES 54ALS/74ALS AND 54AS/74AS DEVICES

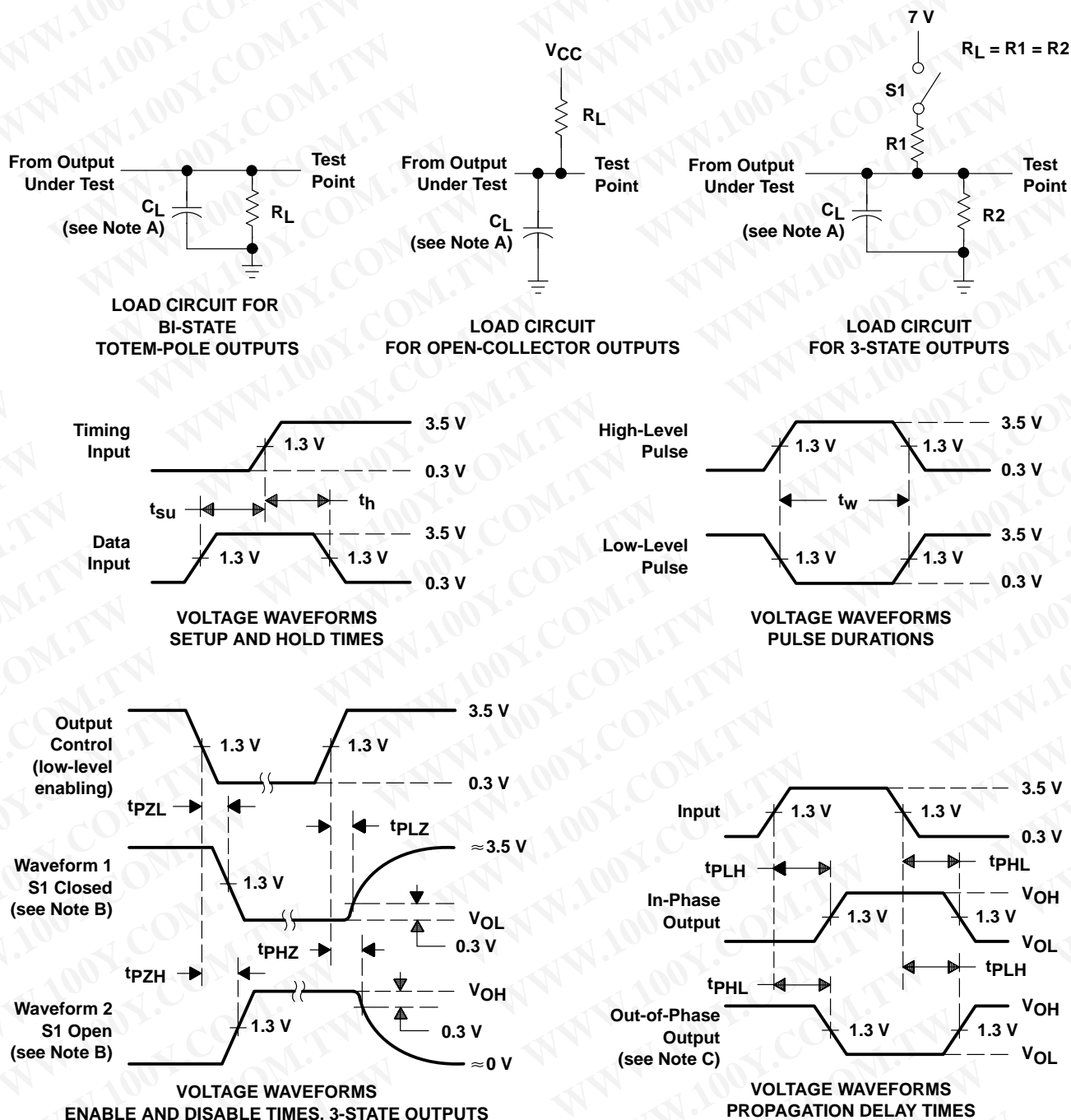

- NOTES: A. C_L includes probe and jig capacitance.
 B. Waveform 1 is for an output with internal conditions such that the output is low except when disabled by the output control. Waveform 2 is for an output with internal conditions such that the output is high except when disabled by the output control.
 C. When measuring propagation delay items of 3-state outputs, switch S1 is open.
 D. All input pulses have the following characteristics: $PRR \leq 1$ MHz, $t_r = t_f = 2$ ns, duty cycle = 50%.
 E. The outputs are measured one at a time with one transition per measurement.

Figure 1. Load Circuits and Voltage Waveforms

IMPORTANT NOTICE

Texas Instruments (TI) reserves the right to make changes to its products or to discontinue any semiconductor product or service without notice, and advises its customers to obtain the latest version of relevant information to verify, before placing orders, that the information being relied on is current.

TI warrants performance of its semiconductor products and related software to the specifications applicable at the time of sale in accordance with TI's standard warranty. Testing and other quality control techniques are utilized to the extent TI deems necessary to support this warranty. Specific testing of all parameters of each device is not necessarily performed, except those mandated by government requirements.

Certain applications using semiconductor products may involve potential risks of death, personal injury, or severe property or environmental damage ("Critical Applications").

TI SEMICONDUCTOR PRODUCTS ARE NOT DESIGNED, INTENDED, AUTHORIZED, OR WARRANTED TO BE SUITABLE FOR USE IN LIFE-SUPPORT APPLICATIONS, DEVICES OR SYSTEMS OR OTHER CRITICAL APPLICATIONS.

Inclusion of TI products in such applications is understood to be fully at the risk of the customer. Use of TI products in such applications requires the written approval of an appropriate TI officer. Questions concerning potential risk applications should be directed to TI through a local SC sales office.

In order to minimize risks associated with the customer's applications, adequate design and operating safeguards should be provided by the customer to minimize inherent or procedural hazards.

TI assumes no liability for applications assistance, customer product design, software performance, or infringement of patents or services described herein. Nor does TI warrant or represent that any license, either express or implied, is granted under any patent right, copyright, mask work right, or other intellectual property right of TI covering or relating to any combination, machine, or process in which such semiconductor products or services might be or are used.

Copyright © 1996, Texas Instruments Incorporated

勝特力材料 886-3-5753170
勝特力电子(上海) 86-21-34970699
勝特力电子(深圳) 86-755-83298787
[Http://www.100y.com.tw](http://www.100y.com.tw)

N (R-PDIP-T**)

PLASTIC DUAL-IN-LINE PACKAGE

16 PINS SHOWN

DIM \ PINS **	14	16	18	20
A MAX	0.775 (19,69)	0.775 (19,69)	0.920 (23,37)	0.975 (24,77)
A MIN	0.745 (18,92)	0.745 (18,92)	0.850 (21,59)	0.940 (23,88)

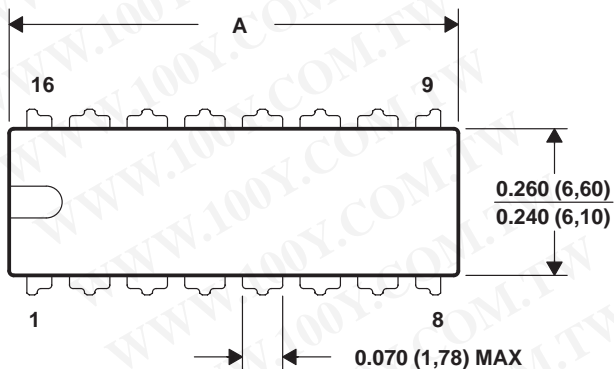

勝特力材料 886-3-5753170
 勝特力电子(上海) 86-21-34970699
 勝特力电子(深圳) 86-755-83298787
[Http://www.100y.com.tw](http://www.100y.com.tw)

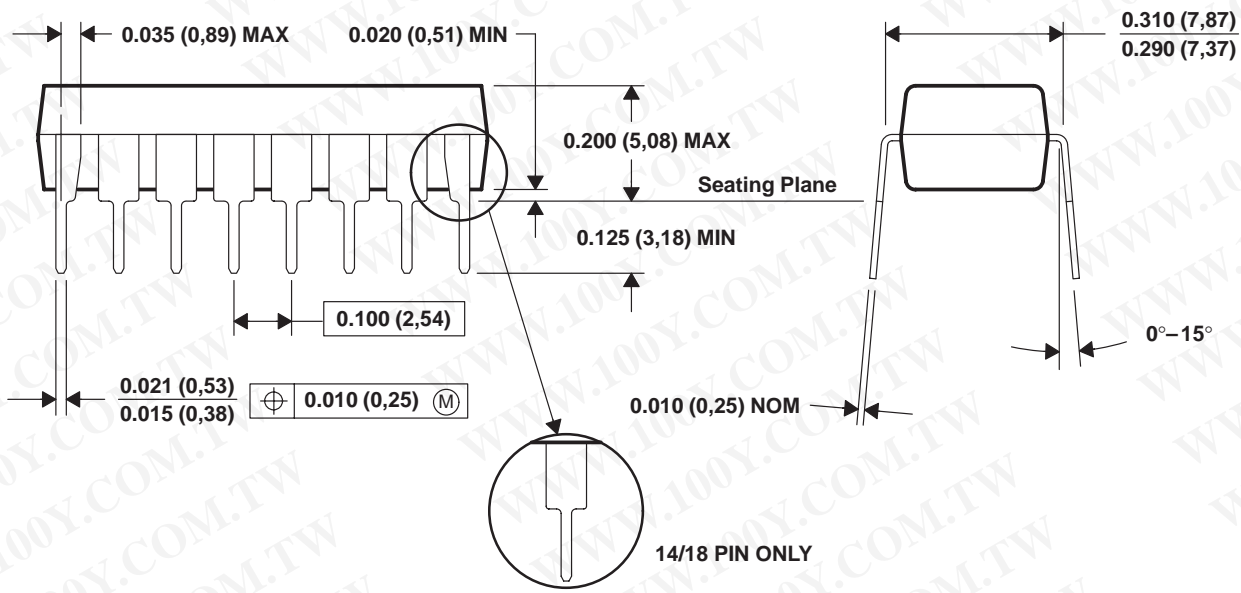

4040049/C 08/95

- NOTES: A. All linear dimensions are in inches (millimeters).
 B. This drawing is subject to change without notice.
 C. Falls within JEDEC MS-001 (20-pin package is shorter than MS-001).