

SN54ALS645A, SN54AS645, SN74ALS645A, SN74AS645 OCTAL BUS TRANSCEIVERS WITH 3-STATE OUTPUTS

SDAS278 – JANUARY 1995

- Bidirectional Bus Transceivers in High-Density 20-Pin Packages
- True Logic
- 3-State Outputs
- Package Options Include Plastic Small-Outline (DW) Packages, Ceramic Chip Carriers (FK), and Standard Plastic (N) and Ceramic (J) 300-mil DIPs

description

These octal bus transceivers are designed for asynchronous two-way communication between data buses. These devices transmit data from the A bus to the B bus or from the B bus to the A bus, depending on the level at the direction-control (DIR) input. The output-enable (\overline{OE}) input can be used to disable the device so that the buses are effectively isolated.

The -1 version of the SN74ALS645A is identical to the standard version, except that the recommended maximum I_{OL} is increased to 48 mA. There is no -1 version of the SN54ALS645A.

The SN54ALS645A and SN54AS645 are characterized for operation over the full military temperature range of -55°C to 125°C . The SN74ALS645A and SN74AS645 are characterized for operation from 0°C to 70°C .

SN54ALS645A, SN54AS645 . . . J PACKAGE
SN74ALS645A, SN74AS645 . . . DW OR N PACKAGE
(TOP VIEW)

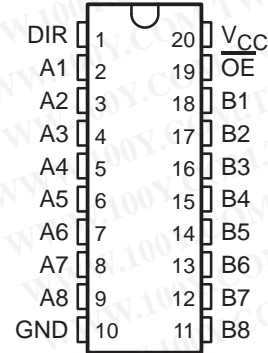

SN54ALS645A, SN54AS645 . . . FK PACKAGE
(TOP VIEW)

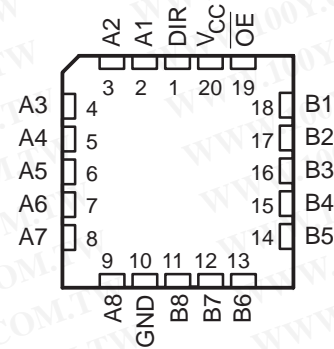

FUNCTION TABLE

INPUTS		OPERATION
\overline{OE}	DIR	
L	L	B data to A bus
L	H	A data to B bus
H	X	Isolation

勝特力材料 886-3-5753170
 勝特力电子(上海) 86-21-34970699
 勝特力电子(深圳) 86-755-83298787
[Http://www.100y.com.tw](http://www.100y.com.tw)

SN54ALS645A, SN54AS645, SN74ALS645A, SN74AS645

OCTAL BUS TRANSCEIVERS WITH 3-STATE OUTPUTS

SDAS278 – JANUARY 1995

logic symbol†

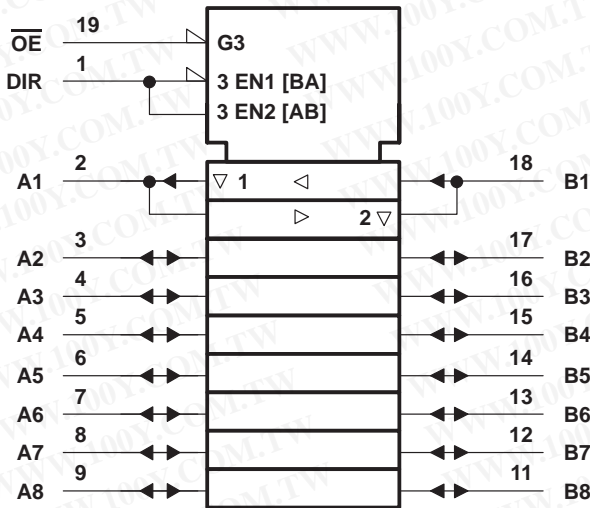

logic diagram (positive logic)

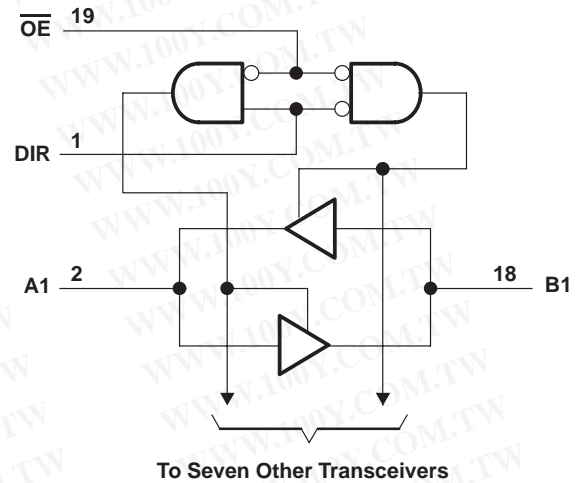

† This symbol is in accordance with ANSI/IEEE Std 91-1984 and IEC Publication 617-12.

absolute maximum ratings over operating free-air temperature range (unless otherwise noted)‡

Supply voltage, V_{CC}	7 V
Input voltage, V_I : All inputs	7 V
I/O ports	5.5 V
Operating free-air temperature range, T_A : SN54ALS645A	-55°C to 125°C
SN74ALS645A	0°C to 70°C
Storage temperature range	-65°C to 150°C

‡ Stresses beyond those listed under "absolute maximum ratings" may cause permanent damage to the device. These are stress ratings only, and functional operation of the device at these or any other conditions beyond those indicated under "recommended operating conditions" is not implied. Exposure to absolute-maximum-rated conditions for extended periods may affect device reliability.

recommended operating conditions

	SN54ALS645A			SN74ALS645A			UNIT
	MIN	NOM	MAX	MIN	NOM	MAX	
V_{CC} Supply voltage	4.5	5	5.5	4.5	5	5.5	V
V_{IH} High-level input voltage	2			2			V
V_{IL} Low-level input voltage			0.7			0.8	V
I_{OH} High-level output current			-12			-15	mA
I_{OL} Low-level output current			12			24	mA
						48§	
T_A Operating free-air temperature	-55		125	0		70	°C

§ Applies only to the -1 version and only if V_{CC} is between 4.75 V and 5.25 V

SN54ALS645A, SN54AS645, SN74ALS645A, SN74AS645

OCTAL BUS TRANSCEIVERS WITH 3-STATE OUTPUTS

SDAS278 – JANUARY 1995

electrical characteristics over recommended operating free-air temperature range (unless otherwise noted)

PARAMETER		TEST CONDITIONS		SN54ALS645A		SN74ALS645A		UNIT
				MIN	TYP†	MAX	MIN	
V _{IK}		V _{CC} = 4.5 V,	I _I = -18 mA	-1.5		-1.5		V
V _{OH}		V _{CC} = 4.5 V to 5.5 V,	I _{OH} = -0.4 mA	V _{CC} - 2		V _{CC} - 2		V
		V _{CC} = 4.5 V	I _{OH} = -3 mA	2.4	3.2	2.4	3.2	
			I _{OH} = -12 mA	2		2		
V _{OL}		V _{CC} = 4.5 V	I _{OL} = 12 mA	0.25	0.4	0.25	0.4	V
			I _{OL} = 24 mA			0.35	0.5	
			I _{OL} = 48 mA‡			0.35	0.5	
I _I	Control inputs	V _{CC} = 5.5 V	V _I = 7 V	0.1		0.1		mA
	A or B ports		V _I = 5.5 V	0.1		0.1		
I _{IH}	Control inputs	V _{CC} = 5.5 V,	V _I = 2.7 V	20		20		μA
	A or B ports§			20		20		
I _{IL}	Control inputs	V _{CC} = 5.5 V,	V _I = 0.4 V	-0.1		-0.1		mA
	A or B ports§			-0.1		-0.1		
I _O ¶		V _{CC} = 5.5 V,	V _O = 2.25 V	-20	-112	-30	-112	mA
I _{CC}		V _{CC} = 5.5 V	Outputs high	30	48	30	45	mA
			Outputs low	36	60	36	55	
			Outputs disabled	38	63	38	58	

† All typical values are at V_{CC} = 5 V, T_A = 25°C.

‡ Applies only to the -1 version and only if V_{CC} is between 4.75 V and 5.25 V

§ For I/O ports, the parameters I_{IH} and I_{IL} include the off-state output current.

¶ The output conditions have been chosen to produce a current that closely approximates one half of the true short-circuit output current, I_{OS}.

switching characteristics (see Figure 1)

PARAMETER	FROM (INPUT)	TO (OUTPUT)	V _{CC} = 4.5 V to 5.5 V, C _L = 50 pF, R ₁ = 500 Ω, R ₂ = 500 Ω, T _A = MIN to MAX#				UNIT
			SN54ALS645A		SN74ALS645A		
			MIN	MAX	MIN	MAX	
t _{PLH}	A or B	B or A	1	19	3	10	ns
t _{PHL}			1	14	3	10	
t _{PZH}	$\overline{\text{OE}}$	A or B	2	30	5	20	ns
t _{PZL}			2	29	5	20	
t _{PHZ}	$\overline{\text{OE}}$	A or B	2	14	2	10	ns
t _{PLZ}			2	30	4	15	

For conditions shown as MIN or MAX, use the appropriate value specified under recommended operating conditions.

SN54ALS645A, SN54AS645, SN74ALS645A, SN74AS645

OCTAL BUS TRANSCEIVERS

WITH 3-STATE OUTPUTS

SDAS278 – JANUARY 1995

absolute maximum ratings over operating free-air temperature range (unless otherwise noted)†

Supply voltage, V_{CC}	7 V
Input voltage, V_I : All inputs	7 V
I/O ports	5.5 V
Operating free-air temperature range, T_A : SN54AS645	-55°C to 125°C
SN74AS645	0°C to 70°C
Storage temperature range	-65°C to 150°C

† Stresses beyond those listed under “absolute maximum ratings” may cause permanent damage to the device. These are stress ratings only, and functional operation of the device at these or any other conditions beyond those indicated under “recommended operating conditions” is not implied. Exposure to absolute-maximum-rated conditions for extended periods may affect device reliability.

recommended operating conditions

	SN54AS645			SN74AS645			UNIT
	MIN	NOM	MAX	MIN	NOM	MAX	
V_{CC} Supply voltage	4.5	5	5.5	4.5	5	5.5	V
V_{IH} High-level input voltage	2			2			V
V_{IL} Low-level input voltage			0.8			0.8	V
I_{OH} High-level output current			-12			-15	mA
I_{OL} Low-level output current			48			64	mA
T_A Operating free-air temperature	-55		125	0		70	°C

electrical characteristics over recommended operating free-air temperature range (unless otherwise noted)

PARAMETER	TEST CONDITIONS	SN54AS645			SN74AS645			UNIT
		MIN	TYP‡	MAX	MIN	TYP‡	MAX	
V_{IK}	$V_{CC} = 4.5$ V, $I_I = -18$ mA			-1.2			-1.2	V
V_{OH}	$V_{CC} = 4.5$ V to 5.5 V, $I_{OH} = -2$ mA	$V_{CC} - 2$		$V_{CC} - 2$				V
	$V_{CC} = 4.5$ V, $I_{OH} = -3$ mA	2.4	3.2	2.4	3.2			
	$V_{CC} = 4.5$ V, $I_{OH} = -12$ mA	2.4						
	$V_{CC} = 4.5$ V, $I_{OH} = -15$ mA				2.4			
V_{OL}	$V_{CC} = 4.5$ V, $I_{OL} = 48$ mA		0.3	0.55				V
	$V_{CC} = 4.5$ V, $I_{OL} = 64$ mA				0.35	0.55		
I_I	Control inputs	$V_{CC} = 5.5$ V		$V_I = 7$ V		0.1		mA
	A or B ports	$V_{CC} = 5.5$ V		$V_I = 5.5$ V		0.1		
I_{IH}	Control inputs	$V_{CC} = 5.5$ V		$V_I = 2.7$ V		20		μ A
	A or B ports§	$V_{CC} = 5.5$ V		$V_I = 2.7$ V		70		
I_{IL}	Control inputs	$V_{CC} = 5.5$ V		$V_I = 0.4$ V		-0.5		mA
	A or B ports§	$V_{CC} = 5.5$ V		$V_I = 0.4$ V		-0.75		
I_{O}^{\parallel}	$V_{CC} = 5.5$ V, $V_O = 2.25$ V	-50		-150	-50		-150	mA
I_{CC}	$V_{CC} = 5.5$ V	Outputs high		62	97	62	97	mA
		Outputs low		95	149	95	149	
		Outputs disabled		79	123	79	123	

‡ All typical values are at $V_{CC} = 5$ V, $T_A = 25^\circ\text{C}$.

§ For I/O ports, the parameters I_{IH} and I_{IL} include the off-state output current.

¶ The output conditions have been chosen to produce a current that closely approximates one half of the true short-circuit output current, I_{OS} .



SN54ALS645A, SN54AS645, SN74ALS645A, SN74AS645
**OCTAL BUS TRANSCEIVERS
 WITH 3-STATE OUTPUTS**

SDAS278 – JANUARY 1995

switching characteristics (see Figure 1)

PARAMETER	FROM (INPUT)	TO (OUTPUT)	$V_{CC} = 4.5\text{ V to }5.5\text{ V}$, $C_L = 50\text{ pF}$, $R_1 = 500\ \Omega$, $R_2 = 500\ \Omega$, $T_A = \text{MIN to MAX}^\dagger$				UNIT
			SN54AS645		SN74AS645		
			MIN	MAX	MIN	MAX	
t_{PLH}	A or B	B or A	2	11	2	9.5	ns
t_{PHL}			2	10.5	2	9	
t_{PZH}	\overline{OE}	A or B	2	12	2	11	ns
t_{PZL}			2	12	2	10	
t_{PHZ}	\overline{OE}	A or B	2	8	2	7	ns
t_{PLZ}			2	13	2	12	

[†] For conditions shown as MIN or MAX, use the appropriate value specified under recommended operating conditions.

SN54ALS645A, SN54AS645, SN74ALS645A, SN74AS645 OCTAL BUS TRANSCEIVERS WITH 3-STATE OUTPUTS

SDAS278 – JANUARY 1995

PARAMETER MEASUREMENT INFORMATION SERIES 54ALS/74ALS AND 54AS/74AS DEVICES

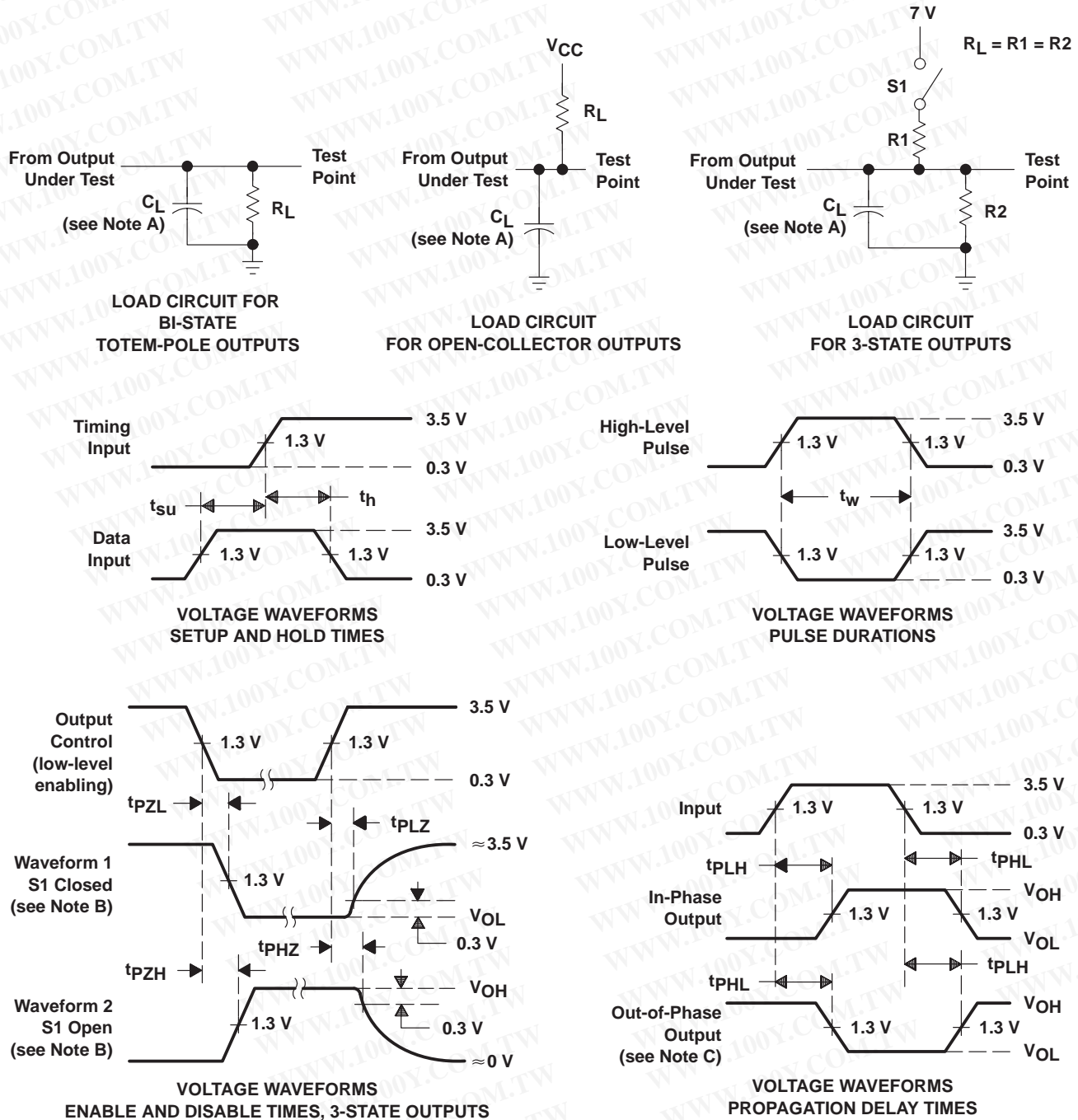

- NOTES: A. C_L includes probe and jig capacitance.
 B. Waveform 1 is for an output with internal conditions such that the output is low except when disabled by the output control. Waveform 2 is for an output with internal conditions such that the output is high except when disabled by the output control.
 C. When measuring propagation delay items of 3-state outputs, switch S1 is open.
 D. All input pulses have the following characteristics: $PRR \leq 1$ MHz, $t_r = t_f = 2$ ns, duty cycle = 50%.
 E. The outputs are measured one at a time with one transition per measurement.

Figure 1. Load Circuits and Voltage Waveforms

PACKAGING INFORMATION

Orderable Device	Status ⁽¹⁾	Package Type	Package Drawing	Pins	Package Qty	Eco Plan ⁽²⁾	Lead/Ball Finish	MSL Peak Temp ⁽³⁾
84033012A	ACTIVE	LCCC	FK	20	1	TBD	POST-PLATE	N / A for Pkg Type
8403301RA	ACTIVE	CDIP	J	20	1	TBD	A42	N / A for Pkg Type
8403301SA	ACTIVE	CFP	W	20	1	TBD	Call TI	N / A for Pkg Type
SN54ALS645AJ	ACTIVE	CDIP	J	20	1	TBD	A42	N / A for Pkg Type
SN54AS645J	ACTIVE	CDIP	J	20	1	TBD	A42	N / A for Pkg Type
SN74ALS645A-1DW	ACTIVE	SOIC	DW	20	25	Green (RoHS & no Sb/Br)	CU NIPDAU	Level-1-260C-UNLIM
SN74ALS645A-1DWE4	ACTIVE	SOIC	DW	20	25	Green (RoHS & no Sb/Br)	CU NIPDAU	Level-1-260C-UNLIM
SN74ALS645A-1DWG4	ACTIVE	SOIC	DW	20	25	Green (RoHS & no Sb/Br)	CU NIPDAU	Level-1-260C-UNLIM
SN74ALS645A-1DWR	ACTIVE	SOIC	DW	20	2000	Green (RoHS & no Sb/Br)	CU NIPDAU	Level-1-260C-UNLIM
SN74ALS645A-1DWRE4	ACTIVE	SOIC	DW	20	2000	Green (RoHS & no Sb/Br)	CU NIPDAU	Level-1-260C-UNLIM
SN74ALS645A-1DWRG4	ACTIVE	SOIC	DW	20	2000	Green (RoHS & no Sb/Br)	CU NIPDAU	Level-1-260C-UNLIM
SN74ALS645A-1N	ACTIVE	PDIP	N	20	20	Pb-Free (RoHS)	CU NIPDAU	N / A for Pkg Type
SN74ALS645A-1N3	OBSOLETE	PDIP	N	20		TBD	Call TI	Call TI
SN74ALS645A-1NE4	ACTIVE	PDIP	N	20	20	Pb-Free (RoHS)	CU NIPDAU	N / A for Pkg Type
SN74ALS645A-1NSR	ACTIVE	SO	NS	20	2000	Green (RoHS & no Sb/Br)	CU NIPDAU	Level-1-260C-UNLIM
SN74ALS645A-1NSRE4	ACTIVE	SO	NS	20	2000	Green (RoHS & no Sb/Br)	CU NIPDAU	Level-1-260C-UNLIM
SN74ALS645A-1NSRG4	ACTIVE	SO	NS	20	2000	Green (RoHS & no Sb/Br)	CU NIPDAU	Level-1-260C-UNLIM
SN74ALS645ADW	ACTIVE	SOIC	DW	20	25	Green (RoHS & no Sb/Br)	CU NIPDAU	Level-1-260C-UNLIM
SN74ALS645ADWE4	ACTIVE	SOIC	DW	20	25	Green (RoHS & no Sb/Br)	CU NIPDAU	Level-1-260C-UNLIM
SN74ALS645ADWG4	ACTIVE	SOIC	DW	20	25	Green (RoHS & no Sb/Br)	CU NIPDAU	Level-1-260C-UNLIM
SN74ALS645ADWR	ACTIVE	SOIC	DW	20	2000	Green (RoHS & no Sb/Br)	CU NIPDAU	Level-1-260C-UNLIM
SN74ALS645ADWRE4	ACTIVE	SOIC	DW	20	2000	Green (RoHS & no Sb/Br)	CU NIPDAU	Level-1-260C-UNLIM
SN74ALS645ADWRG4	ACTIVE	SOIC	DW	20	2000	Green (RoHS & no Sb/Br)	CU NIPDAU	Level-1-260C-UNLIM
SN74ALS645AN	ACTIVE	PDIP	N	20	20	Pb-Free (RoHS)	CU NIPDAU	N / A for Pkg Type
SN74ALS645AN3	OBSOLETE	PDIP	N	20		TBD	Call TI	Call TI
SN74ALS645ANE4	ACTIVE	PDIP	N	20	20	Pb-Free (RoHS)	CU NIPDAU	N / A for Pkg Type
SN74ALS645ANSR	ACTIVE	SO	NS	20	2000	Green (RoHS & no Sb/Br)	CU NIPDAU	Level-1-260C-UNLIM
SN74ALS645ANSRE4	ACTIVE	SO	NS	20	2000	Green (RoHS & no Sb/Br)	CU NIPDAU	Level-1-260C-UNLIM

Orderable Device	Status ⁽¹⁾	Package Type	Package Drawing	Pins	Package Qty	Eco Plan ⁽²⁾	Lead/Ball Finish	MSL Peak Temp ⁽³⁾
						no Sb/Br)		
SN74ALS645ANSRG4	ACTIVE	SO	NS	20	2000	Green (RoHS & no Sb/Br)	CU NIPDAU	Level-1-260C-UNLIM
SN74AS645DW	ACTIVE	SOIC	DW	20	25	Green (RoHS & no Sb/Br)	CU NIPDAU	Level-1-260C-UNLIM
SN74AS645DWE4	ACTIVE	SOIC	DW	20	25	Green (RoHS & no Sb/Br)	CU NIPDAU	Level-1-260C-UNLIM
SN74AS645DWG4	ACTIVE	SOIC	DW	20	25	Green (RoHS & no Sb/Br)	CU NIPDAU	Level-1-260C-UNLIM
SN74AS645N	ACTIVE	PDIP	N	20	20	Pb-Free (RoHS)	CU NIPDAU	N / A for Pkg Type
SN74AS645NE4	ACTIVE	PDIP	N	20	20	Pb-Free (RoHS)	CU NIPDAU	N / A for Pkg Type
SNJ54ALS645AFK	ACTIVE	LCCC	FK	20	1	TBD	POST-PLATE	N / A for Pkg Type
SNJ54ALS645AJ	ACTIVE	CDIP	J	20	1	TBD	A42	N / A for Pkg Type
SNJ54ALS645AW	ACTIVE	CFP	W	20	1	TBD	Call TI	N / A for Pkg Type
SNJ54AS645FK	OBSOLETE	LCCC	FK	20		TBD	Call TI	Call TI
SNJ54AS645J	ACTIVE	CDIP	J	20	1	TBD	A42	N / A for Pkg Type
SNJ54AS645W	ACTIVE	CFP	W	20	1	TBD	Call TI	N / A for Pkg Type

⁽¹⁾ The marketing status values are defined as follows:

ACTIVE: Product device recommended for new designs.

LIFEBUY: TI has announced that the device will be discontinued, and a lifetime-buy period is in effect.

NRND: Not recommended for new designs. Device is in production to support existing customers, but TI does not recommend using this part in a new design.

PREVIEW: Device has been announced but is not in production. Samples may or may not be available.

OBSOLETE: TI has discontinued the production of the device.

⁽²⁾ Eco Plan - The planned eco-friendly classification: Pb-Free (RoHS), Pb-Free (RoHS Exempt), or Green (RoHS & no Sb/Br) - please check <http://www.ti.com/productcontent> for the latest availability information and additional product content details.

TBD: The Pb-Free/Green conversion plan has not been defined.

Pb-Free (RoHS): TI's terms "Lead-Free" or "Pb-Free" mean semiconductor products that are compatible with the current RoHS requirements for all 6 substances, including the requirement that lead not exceed 0.1% by weight in homogeneous materials. Where designed to be soldered at high temperatures, TI Pb-Free products are suitable for use in specified lead-free processes.

Pb-Free (RoHS Exempt): This component has a RoHS exemption for either 1) lead-based flip-chip solder bumps used between the die and package, or 2) lead-based die adhesive used between the die and leadframe. The component is otherwise considered Pb-Free (RoHS compatible) as defined above.

Green (RoHS & no Sb/Br): TI defines "Green" to mean Pb-Free (RoHS compatible), and free of Bromine (Br) and Antimony (Sb) based flame retardants (Br or Sb do not exceed 0.1% by weight in homogeneous material)

⁽³⁾ MSL, Peak Temp. -- The Moisture Sensitivity Level rating according to the JEDEC industry standard classifications, and peak solder temperature.

Important Information and Disclaimer: The information provided on this page represents TI's knowledge and belief as of the date that it is provided. TI bases its knowledge and belief on information provided by third parties, and makes no representation or warranty as to the accuracy of such information. Efforts are underway to better integrate information from third parties. TI has taken and continues to take reasonable steps to provide representative and accurate information but may not have conducted destructive testing or chemical analysis on incoming materials and chemicals. TI and TI suppliers consider certain information to be proprietary, and thus CAS numbers and other limited information may not be available for release.

In no event shall TI's liability arising out of such information exceed the total purchase price of the TI part(s) at issue in this document sold by TI to Customer on an annual basis.

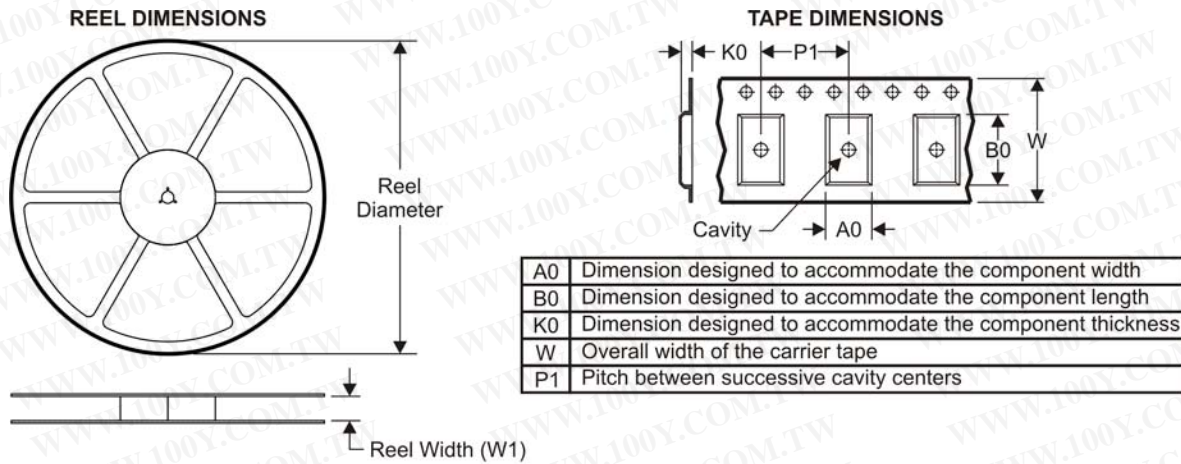
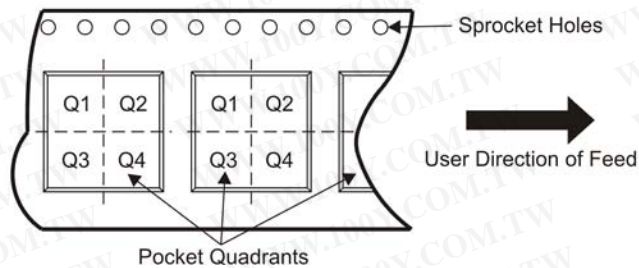
TAPE AND REEL INFORMATION

QUADRANT ASSIGNMENTS FOR PIN 1 ORIENTATION IN TAPE

*All dimensions are nominal

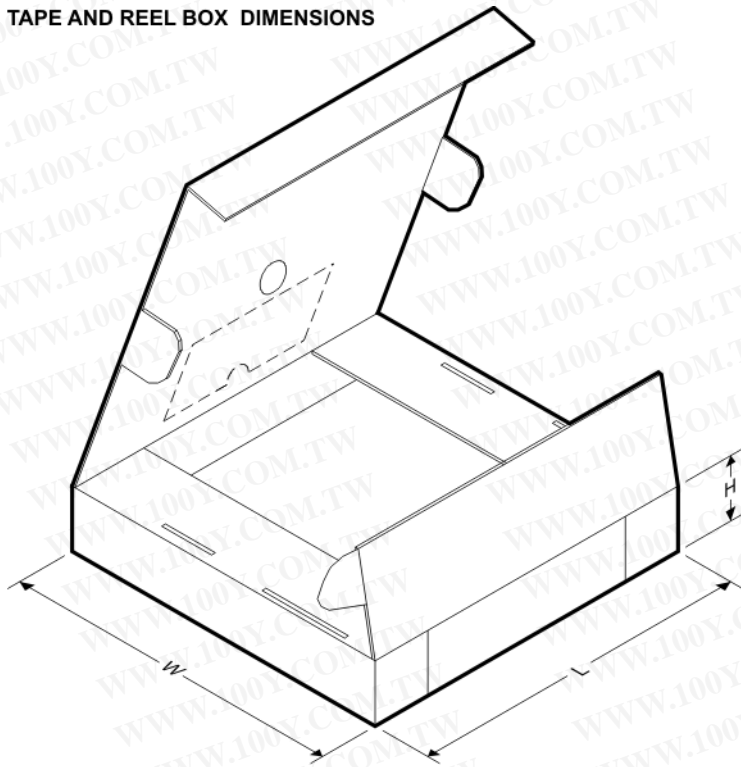
Device	Package Type	Package Drawing	Pins	SPQ	Reel Diameter (mm)	Reel Width W1 (mm)	A0 (mm)	B0 (mm)	K0 (mm)	P1 (mm)	W (mm)	Pin1 Quadrant
SN74ALS645A-1DWR	SOIC	DW	20	2000	330.0	24.4	10.8	13.0	2.7	12.0	24.0	Q1
SN74ALS645A-1NSR	SO	NS	20	2000	330.0	24.4	8.2	13.0	2.5	12.0	24.0	Q1
SN74ALS645ADWR	SOIC	DW	20	2000	330.0	24.4	10.8	13.0	2.7	12.0	24.0	Q1
SN74ALS645ANSR	SO	NS	20	2000	330.0	24.4	8.2	13.0	2.5	12.0	24.0	Q1

TAPE AND REEL BOX DIMENSIONS

*All dimensions are nominal

Device	Package Type	Package Drawing	Pins	SPQ	Length (mm)	Width (mm)	Height (mm)
SN74ALS645A-1DWR	SOIC	DW	20	2000	346.0	346.0	41.0
SN74ALS645A-1NSR	SO	NS	20	2000	346.0	346.0	41.0
SN74ALS645ADWR	SOIC	DW	20	2000	346.0	346.0	41.0
SN74ALS645ANSR	SO	NS	20	2000	346.0	346.0	41.0

FK (S-CQCC-N**)

LEADLESS CERAMIC CHIP CARRIER

28 TERMINAL SHOWN

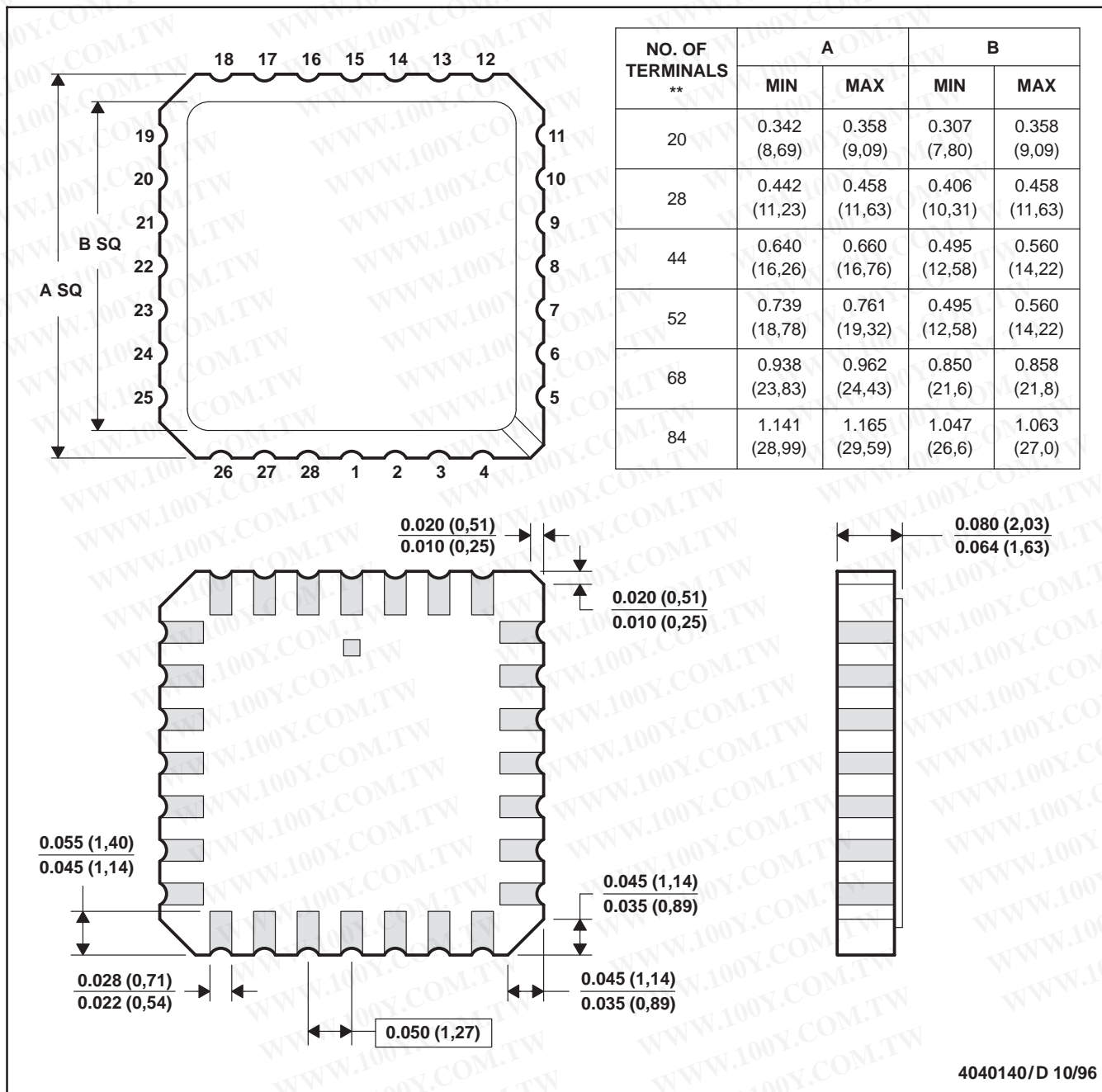

- NOTES:
- A. All linear dimensions are in inches (millimeters).
 - B. This drawing is subject to change without notice.
 - C. This package can be hermetically sealed with a metal lid.
 - D. The terminals are gold plated.
 - E. Falls within JEDEC MS-004

MECHANICAL DATA

NS (R-PDSO-G)**

PLASTIC SMALL-OUTLINE PACKAGE

14-PINS SHOWN

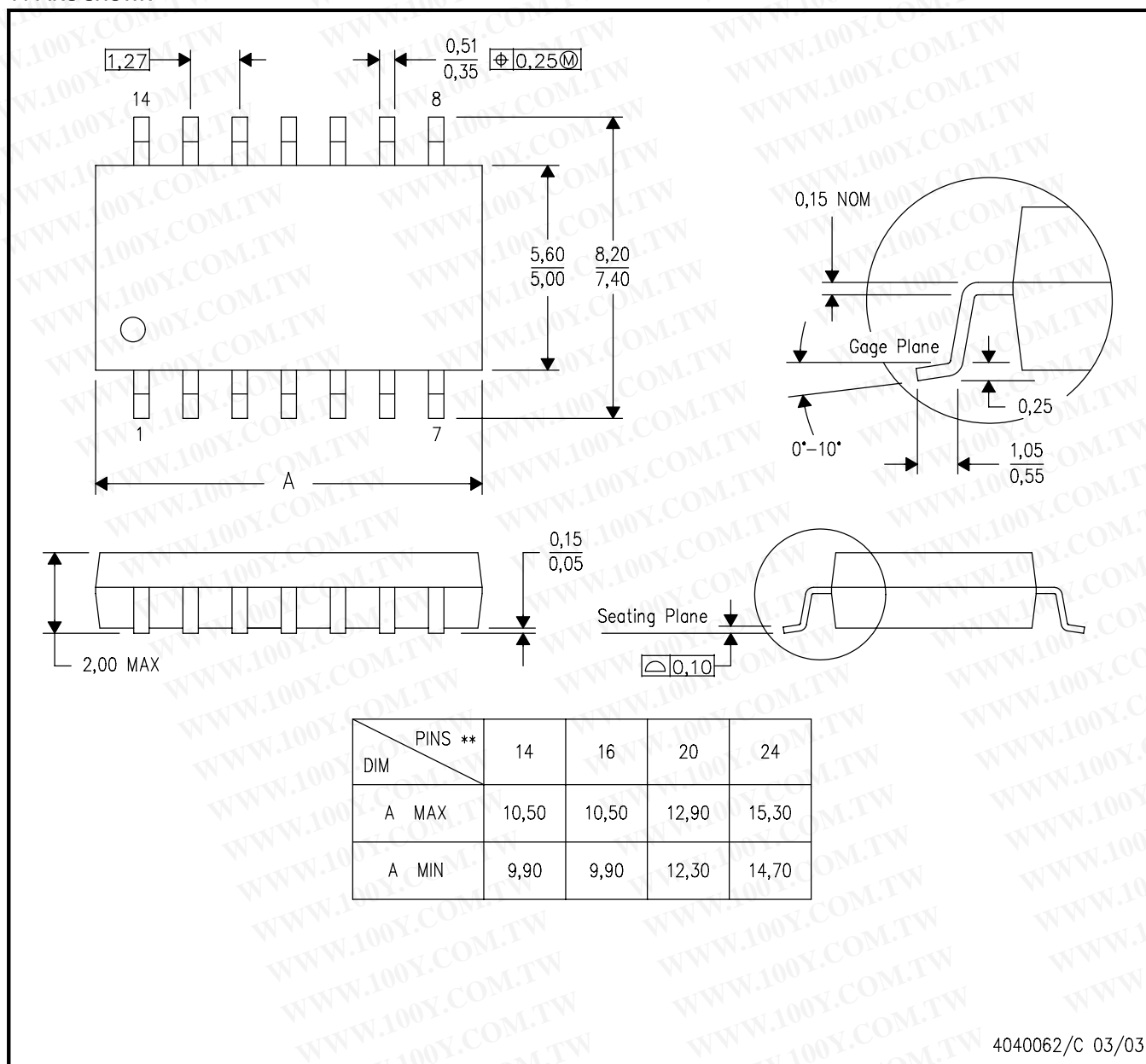

- NOTES:
- A. All linear dimensions are in millimeters.
 - B. This drawing is subject to change without notice.
 - C. Body dimensions do not include mold flash or protrusion, not to exceed 0,15.

J (R-GDIP-T**)
14 LEADS SHOWN

CERAMIC DUAL IN-LINE PACKAGE

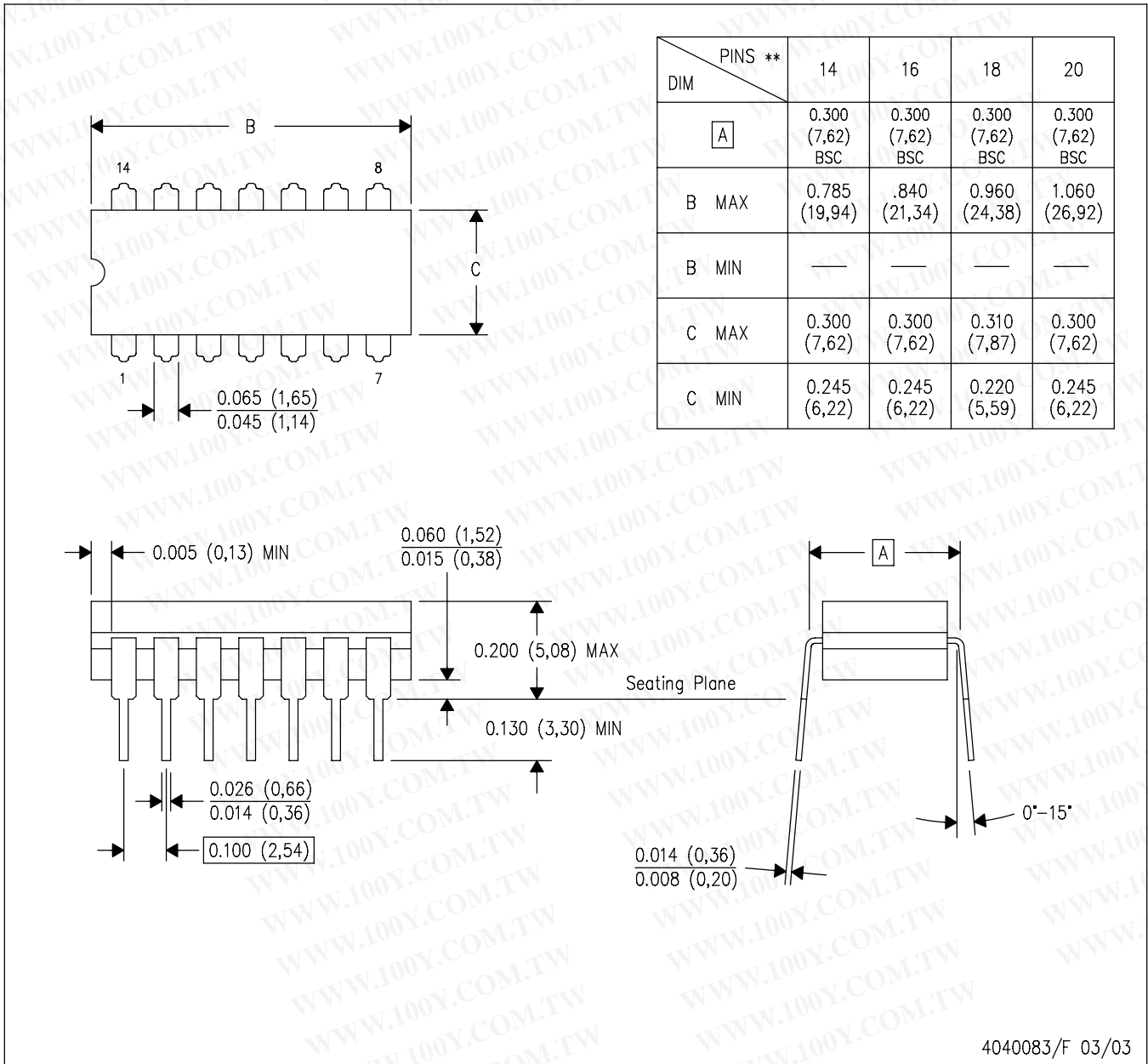

- NOTES:
- A. All linear dimensions are in inches (millimeters).
 - B. This drawing is subject to change without notice.
 - C. This package is hermetically sealed with a ceramic lid using glass frit.
 - D. Index point is provided on cap for terminal identification only on press ceramic glass frit seal only.
 - E. Falls within MIL STD 1835 GDIP1-T14, GDIP1-T16, GDIP1-T18 and GDIP1-T20.

W (R-GDFP-F20)

CERAMIC DUAL FLATPACK

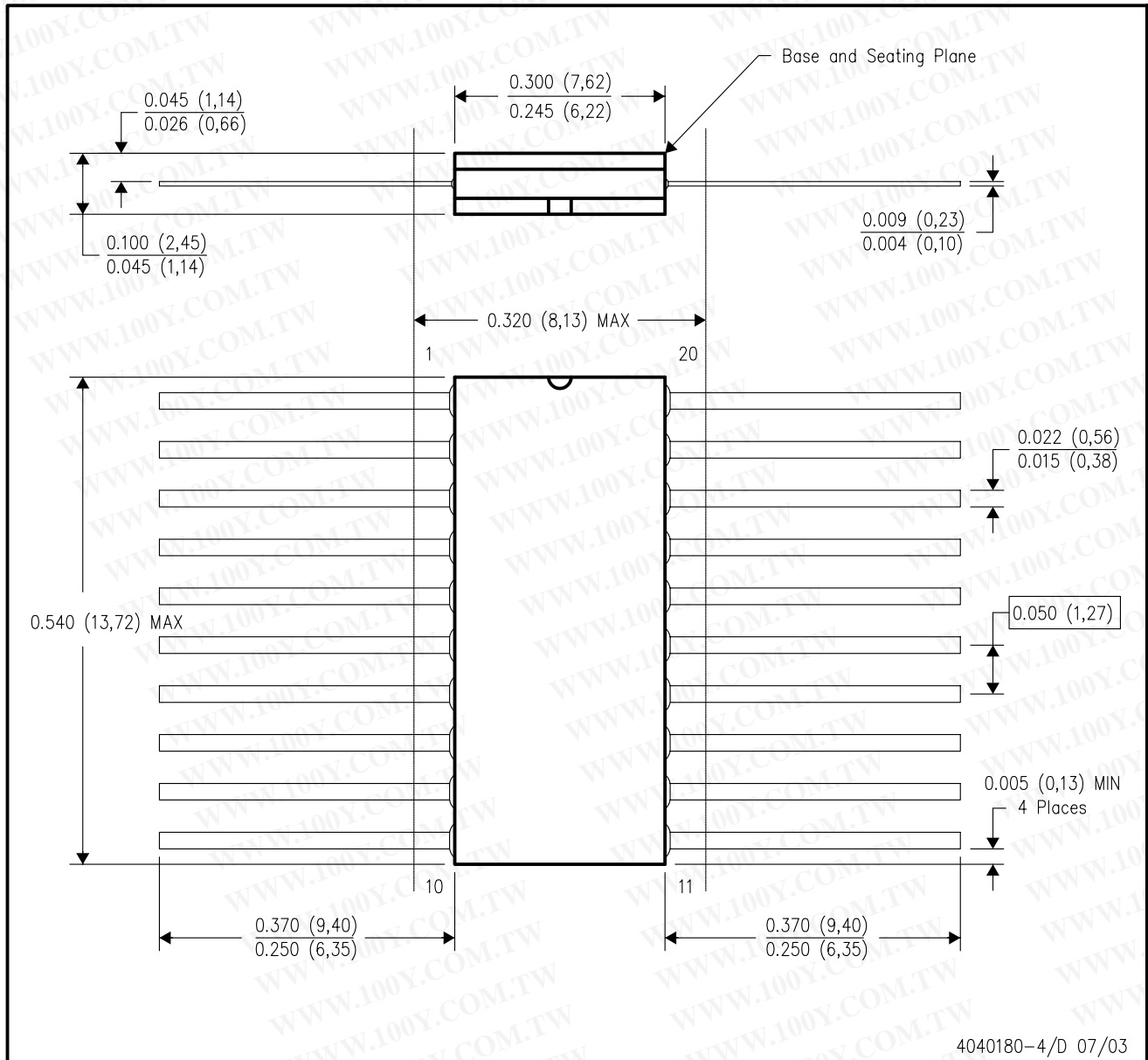

- NOTES:
- A. All linear dimensions are in inches (millimeters).
 - B. This drawing is subject to change without notice.
 - C. This package can be hermetically sealed with a ceramic lid using glass frit.
 - D. Index point is provided on cap for terminal identification only.
 - E. Falls within Mil-Std 1835 GDFP2-F20

DW (R-PDSO-G20)

PLASTIC SMALL-OUTLINE PACKAGE

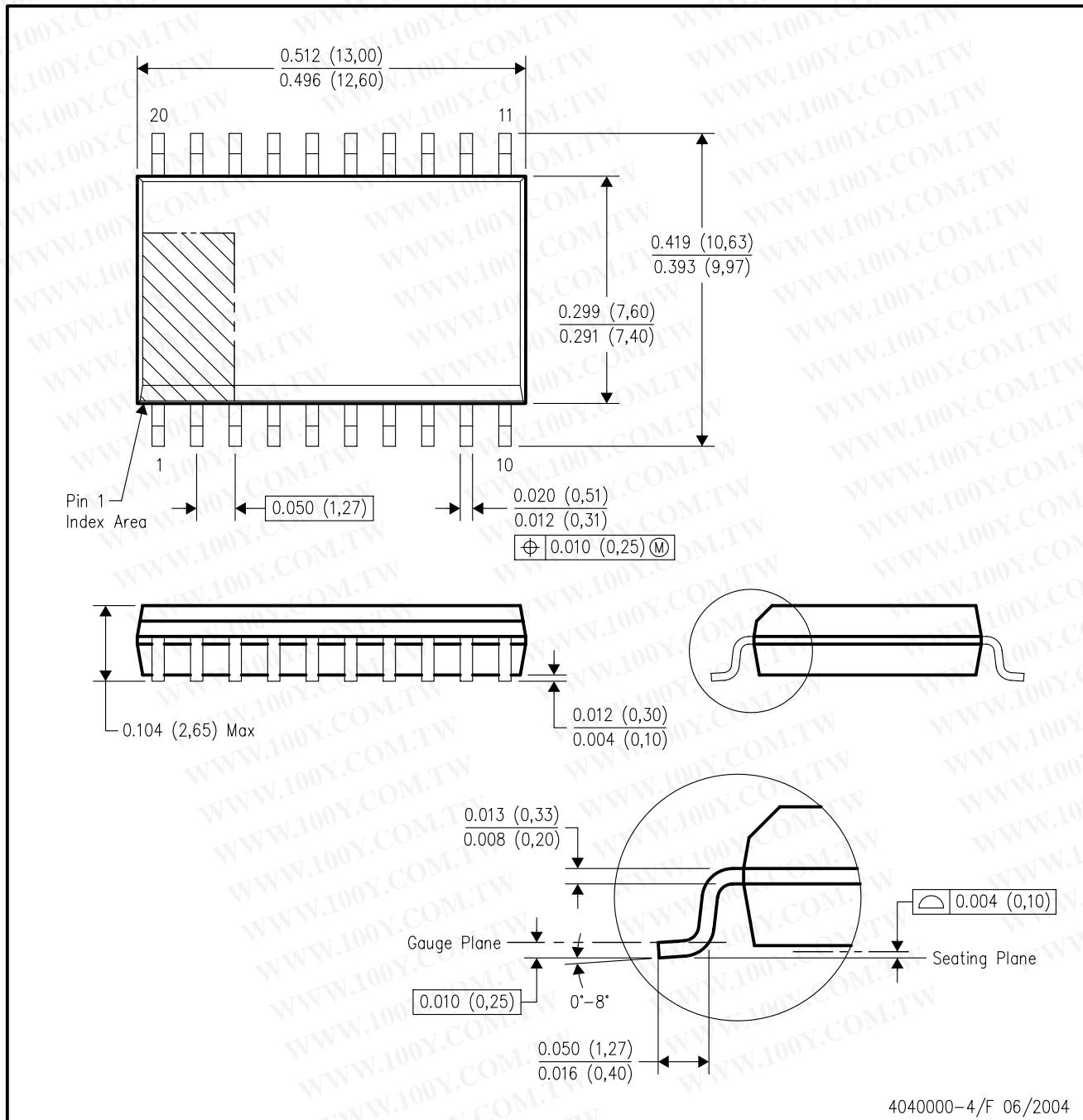

4040000-4/F 06/2004

- NOTES:
- A. All linear dimensions are in inches (millimeters).
 - B. This drawing is subject to change without notice.
 - C. Body dimensions do not include mold flash or protrusion not to exceed 0.006 (0,15).
 - D. Falls within JEDEC MS-013 variation AC.

N (R-PDIP-T**)

PLASTIC DUAL-IN-LINE PACKAGE

16 PINS SHOWN

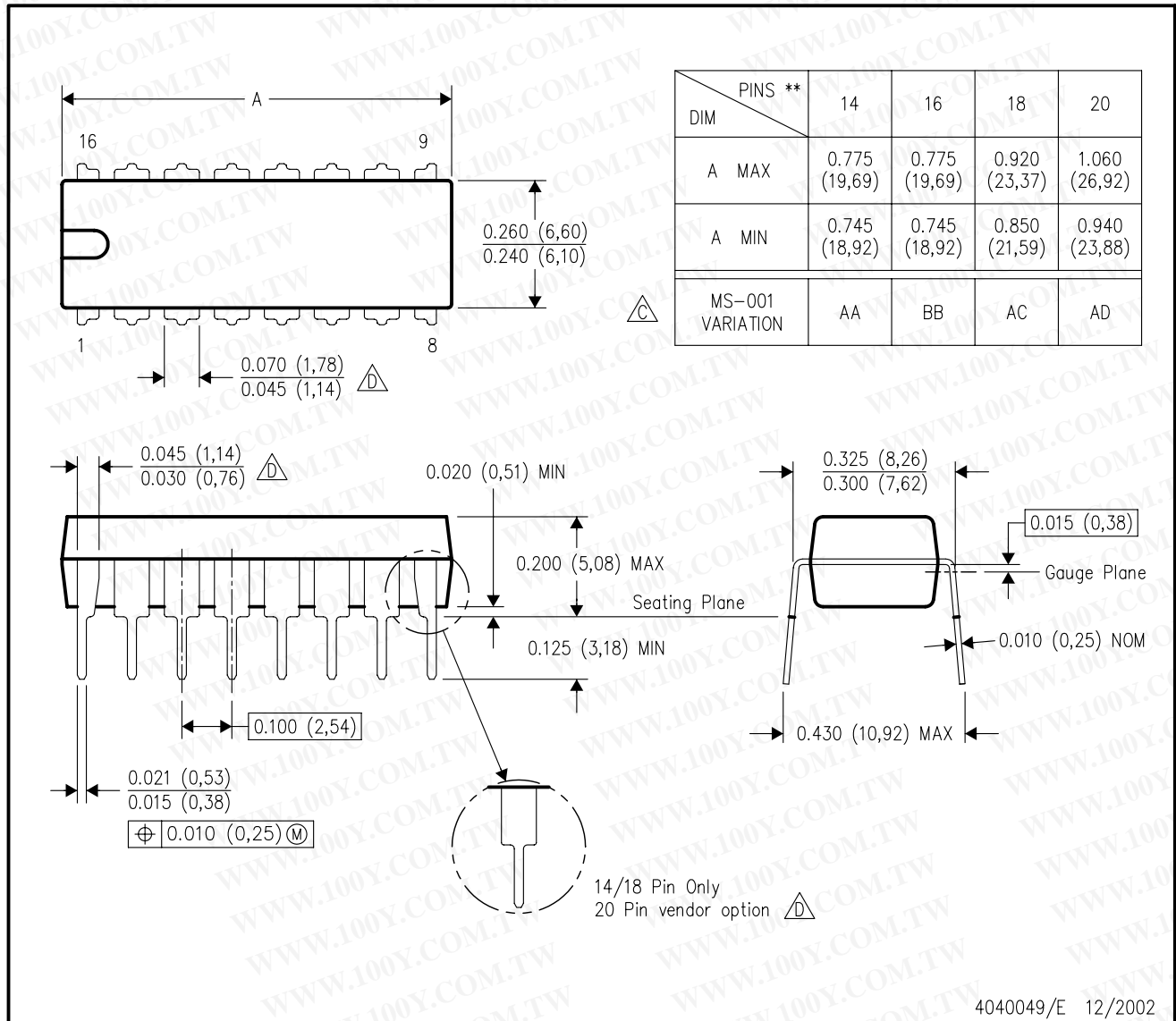

- NOTES:
- A. All linear dimensions are in inches (millimeters).
 - B. This drawing is subject to change without notice.
 - Falls within JEDEC MS-001, except 18 and 20 pin minimum body length (Dim A).
 - The 20 pin end lead shoulder width is a vendor option, either half or full width.

勝特力材料 886-3-5753170
 勝特力电子(上海) 86-21-34970699
 勝特力电子(深圳) 86-755-83298787
[Http://www.100y.com.tw](http://www.100y.com.tw)