

- Wide Operating Voltage Range of 2 V to 6 V
- High-Current 3-State Outputs Interface Directly With System Bus or Can Drive Up To 15 LSTTL Loads
- Low Power Consumption, 80- μ A Max I_{CC}
- Typical $t_{pd} = 11$ ns
- ± 6 -mA Output Drive at 5 V
- Low Input Current of 1 μ A Max

SN54HC126 . . . J OR W PACKAGE
 SN74HC126 . . . D, DB, N, NS, OR PW PACKAGE
 (TOP VIEW)

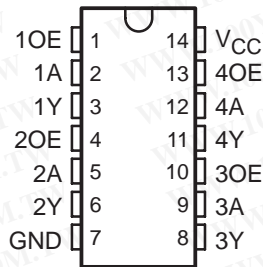

SN54HC126 . . . FK PACKAGE
 (TOP VIEW)

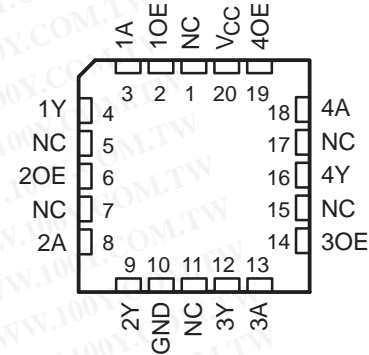

NC – No internal connection

description/ordering information

These quadruple bus buffer gates feature independent line drivers with 3-state outputs. Each output is disabled when the associated output-enable (OE) input is low.

To ensure the high-impedance state during power up or power down, OE should be tied to GND through a pullup resistor; the minimum value of the resistor is determined by the current-sourcing capability of the driver.

ORDERING INFORMATION

| T _A | PACKAGE† | | ORDERABLE PART NUMBER | TOP-SIDE MARKING |
|----------------|------------|--------------|-----------------------|------------------|
| –40°C to 85°C | PDIP – N | Tube of 25 | SN74HC126N | SN74HC126N |
| | | Tube of 50 | SN74HC126D | HC126 |
| | SOIC – D | Reel of 2500 | SN74HC126DR | |
| | | Reel of 250 | SN74HC126DT | |
| | SOP – NS | Reel of 2000 | SN74HC126NSR | HC126 |
| | SSOP – DB | Reel of 2000 | SN74HC126DBR | HC126 |
| | TSSOP – PW | Tube of 90 | SN74HC126PW | HC126 |
| Reel of 2000 | | SN74HC126PWR | | |
| Reel of 250 | | SN74HC126PWT | | |
| –55°C to 125°C | CDIP – J | Tube of 25 | SNJ54HC126J | SNJ54HC126J |
| | CFP – W | Tube of 150 | SNJ54HC126W | SNJ54HC126W |
| | LCCC – FK | Tube of 55 | SNJ54HC126FK | SNJ54HC126FK |

† Package drawings, standard packing quantities, thermal data, symbolization, and PCB design guidelines are available at www.ti.com/sc/package.



Please be aware that an important notice concerning availability, standard warranty, and use in critical applications of Texas Instruments semiconductor products and disclaimers thereto appears at the end of this data sheet.

PRODUCTION DATA information is current as of publication date. Products conform to specifications per the terms of Texas Instruments standard warranty. Production processing does not necessarily include testing of all parameters.

TEXAS
INSTRUMENTS

POST OFFICE BOX 655303 • DALLAS, TEXAS 75265

Copyright © 2003, Texas Instruments Incorporated
 On products compliant to MIL-PRF-38535, all parameters are tested unless otherwise noted. On all other products, production processing does not necessarily include testing of all parameters.

SN54HC126, SN74HC126 QUADRUPLE BUS BUFFER GATES WITH 3-STATE OUTPUTS

SCLS103E – MARCH 1984 – REVISED JULY 2003

FUNCTION TABLE
(each buffer)

| INPUTS | | OUTPUT |
|--------|---|--------|
| OE | A | Y |
| H | H | H |
| H | L | L |
| L | X | Z |

logic diagram (positive logic)

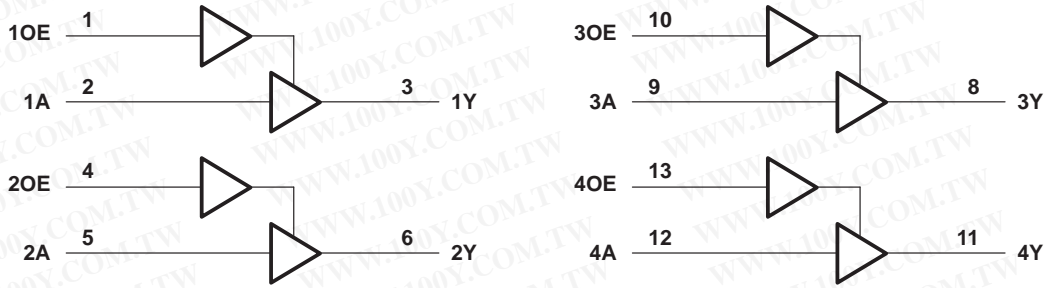

Pin numbers shown are for the D, DB, J, N, NS, PW, and W packages.

absolute maximum ratings over operating free-air temperature range (unless otherwise noted)†

| | |
|---|----------------|
| Supply voltage range, V_{CC} | -0.5 V to 7 V |
| Input clamp current, I_{IK} ($V_I < 0$ or $V_I > V_{CC}$) (see Note 1) | ± 20 mA |
| Output clamp current, I_{OK} ($V_O < 0$ or $V_O > V_{CC}$) (see Note 1) | ± 20 mA |
| Continuous output current, I_O ($V_O = 0$ to V_{CC}) | ± 35 mA |
| Continuous current through V_{CC} or GND | ± 70 mA |
| Package thermal impedance, θ_{JA} (see Note 2): | |
| D package | 86°C/W |
| DB package | 96°C/W |
| N package | 80°C/W |
| NS package | 76°C/W |
| PW package | 113°C/W |
| Storage temperature range, T_{stg} | -65°C to 150°C |

† Stresses beyond those listed under "absolute maximum ratings" may cause permanent damage to the device. These are stress ratings only, and functional operation of the device at these or any other conditions beyond those indicated under "recommended operating conditions" is not implied. Exposure to absolute-maximum-rated conditions for extended periods may affect device reliability.

- NOTES: 1. The input and output voltage ratings may be exceeded if the input and output current ratings are observed.
2. The package thermal impedance is calculated in accordance with JESD 51-7.

勝特力材料 886-3-5753170
勝特力电子(上海) 86-21-34970699
勝特力电子(深圳) 86-755-83298787
[Http://www.100y.com.tw](http://www.100y.com.tw)

SN54HC126, SN74HC126 QUADRUPLE BUS BUFFER GATES WITH 3-STATE OUTPUTS

SCLS103E – MARCH 1984 – REVISED JULY 2003

recommended operating conditions (see Note 3)

| | | SN54HC126 | | | SN74HC126 | | | UNIT |
|-----------------|---------------------------------|-------------------------|-----------------|------|-----------|-----------------|------|------|
| | | MIN | NOM | MAX | MIN | NOM | MAX | |
| V _{CC} | Supply voltage | 2 | 5 | 6 | 2 | 5 | 6 | V |
| V _{IH} | High-level input voltage | V _{CC} = 2 V | | 1.5 | 1.5 | | V | |
| | | V _{CC} = 4.5 V | | 3.15 | 3.15 | | | |
| | | V _{CC} = 6 V | | 4.2 | 4.2 | | | |
| V _{IL} | Low-level input voltage | V _{CC} = 2 V | | | 0.5 | | 0.5 | V |
| | | V _{CC} = 4.5 V | | | 1.35 | | 1.35 | |
| | | V _{CC} = 6 V | | | 1.8 | | 1.8 | |
| V _I | Input voltage | 0 | V _{CC} | | 0 | V _{CC} | | V |
| V _O | Output voltage | 0 | V _{CC} | | 0 | V _{CC} | | V |
| Δt/Δv | Input transition rise/fall time | V _{CC} = 2 V | | 1000 | | 1000 | | ns |
| | | V _{CC} = 4.5 V | | 500 | | 500 | | |
| | | V _{CC} = 6 V | | 400 | | 400 | | |
| T _A | Operating free-air temperature | -55 | | 125 | -40 | | 85 | °C |

NOTE 3: All unused inputs of the device must be held at V_{CC} or GND to ensure proper device operation. Refer to the TI application report, *Implications of Slow or Floating CMOS Inputs*, literature number SCBA004.

electrical characteristics over recommended operating free-air temperature range (unless otherwise noted)

| PARAMETER | TEST CONDITIONS | | V _{CC} | T _A = 25°C | | | SN54HC126 | | SN74HC126 | | UNIT |
|-----------------|---|---------------------------|-----------------|-----------------------|-------|------|-----------|-------|-----------|-------|------|
| | | | | MIN | TYP | MAX | MIN | MAX | MIN | MAX | |
| V _{OH} | V _I = V _{IH} or V _{IL} | I _{OH} = -20 μA | 2 V | 1.9 | 1.998 | | 1.9 | | 1.9 | V | |
| | | | 4.5 V | 4.4 | 4.499 | | 4.4 | | 4.4 | | |
| | | | 6 V | 5.9 | 5.999 | | 5.9 | | 5.9 | | |
| | | I _{OH} = -6 mA | 4.5 V | 3.98 | 4.3 | | 3.7 | | 3.84 | | |
| | | I _{OH} = -7.8 mA | 6 V | 5.48 | 5.8 | | 5.2 | | 5.34 | | |
| V _{OL} | V _I = V _{IH} or V _{IL} | I _{OL} = 20 μA | 2 V | | 0.002 | 0.1 | | 0.1 | | 0.1 | V |
| | | | 4.5 V | | 0.001 | 0.1 | | 0.1 | | 0.1 | |
| | | | 6 V | | 0.001 | 0.1 | | 0.1 | | 0.1 | |
| | | I _{OL} = 6 mA | 4.5 V | | 0.17 | 0.26 | | 0.4 | | 0.33 | |
| | | I _{OL} = 7.8 mA | 6 V | | 0.15 | 0.26 | | 0.4 | | 0.33 | |
| I _I | V _I = V _{CC} or 0 | | 6 V | | ±0.1 | ±100 | | ±1000 | | ±1000 | nA |
| I _{OZ} | V _O = V _{CC} or 0 | | 6 V | | ±0.01 | ±0.5 | | ±10 | | ±5 | μA |
| I _{CC} | V _I = V _{CC} or 0, I _O = 0 | | 6 V | | | 8 | | 160 | | 80 | μA |
| C _i | | | 2 V to 6 V | | 3 | 10 | | 10 | | 10 | pF |

勝特力材料 886-3-5753170
 勝特力电子(上海) 86-21-34970699
 勝特力电子(深圳) 86-755-83298787
[Http://www.100y.com.tw](http://www.100y.com.tw)



SN54HC126, SN74HC126 QUADRUPLE BUS BUFFER GATES WITH 3-STATE OUTPUTS

SCLS103E – MARCH 1984 – REVISED JULY 2003

switching characteristics over recommended operating free-air temperature range, $C_L = 50$ pF (unless otherwise noted) (see Figure 1)

| PARAMETER | FROM (INPUT) | TO (OUTPUT) | V _{CC} | T _A = 25°C | | | SN54HC126 | | SN74HC126 | | UNIT |
|------------------|--------------|-------------|-----------------|-----------------------|-----|-----|-----------|-----|-----------|-----|------|
| | | | | MIN | TYP | MAX | MIN | MAX | MIN | MAX | |
| t _{pd} | A | Y | 2 V | | 47 | 120 | | 180 | | 150 | ns |
| | | | 4.5 V | | 14 | 24 | | 36 | | 30 | |
| | | | 6 V | | 11 | 20 | | 31 | | 26 | |
| t _{en} | OE | Y | 2 V | | 57 | 120 | | 180 | | 150 | ns |
| | | | 4.5 V | | 16 | 24 | | 36 | | 30 | |
| | | | 6 V | | 12 | 20 | | 31 | | 26 | |
| t _{dis} | OE | Y | 2 V | | 35 | 120 | | 180 | | 150 | ns |
| | | | 4.5 V | | 17 | 24 | | 36 | | 30 | |
| | | | 6 V | | 15 | 20 | | 31 | | 26 | |
| t _t | | Any | 2 V | | 28 | 60 | | 90 | | 75 | ns |
| | | | 4.5 V | | 8 | 12 | | 18 | | 15 | |
| | | | 6 V | | 6 | 10 | | 15 | | 13 | |

switching characteristics over recommended operating free-air temperature range, $C_L = 150$ pF (unless otherwise noted) (see Figure 1)

| PARAMETER | FROM (INPUT) | TO (OUTPUT) | V _{CC} | T _A = 25°C | | | SN54HC126 | | SN74HC126 | | UNIT |
|-----------------|--------------|-------------|-----------------|-----------------------|-----|-----|-----------|-----|-----------|-----|------|
| | | | | MIN | TYP | MAX | MIN | MAX | MIN | MAX | |
| t _{pd} | A | Y | 2 V | | 67 | 150 | | 225 | | 188 | ns |
| | | | 4.5 V | | 19 | 30 | | 45 | | 38 | |
| | | | 6 V | | 15 | 25 | | 39 | | 33 | |
| t _{en} | OE | Y | 2 V | | 100 | 135 | | 202 | | 169 | ns |
| | | | 4.5 V | | 20 | 27 | | 40 | | 36 | |
| | | | 6 V | | 17 | 23 | | 36 | | 30 | |
| t _t | | Any | 2 V | | 45 | 210 | | 315 | | 265 | ns |
| | | | 4.5 V | | 17 | 42 | | 63 | | 53 | |
| | | | 6 V | | 13 | 36 | | 53 | | 45 | |

operating characteristics, T_A = 25°C

| PARAMETER | TEST CONDITIONS | TYP | UNIT |
|--|-----------------|-----|------|
| C _{pd} Power dissipation capacitance per gate | No load | 45 | pF |

勝特力材料 886-3-5753170
 勝特力电子(上海) 86-21-34970699
 勝特力电子(深圳) 86-755-83298787
[Http://www.100y.com.tw](http://www.100y.com.tw)



PARAMETER MEASUREMENT INFORMATION

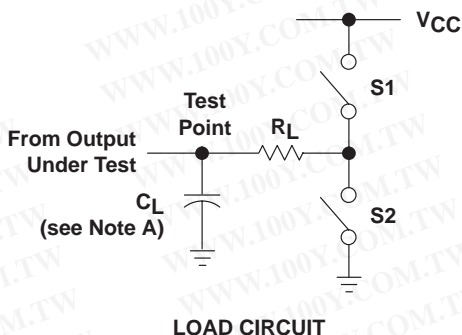

| PARAMETER | R_L | C_L | S1 | S2 |
|-------------------|--------------|-----------------|--------|--------|
| t_{en} | 1 k Ω | 50 pF or 150 pF | Open | Closed |
| | | | Closed | Open |
| t_{dis} | 1 k Ω | 50 pF | Open | Closed |
| | | | Closed | Open |
| t_{pd} or t_t | -- | 50 pF or 150 pF | Open | Open |

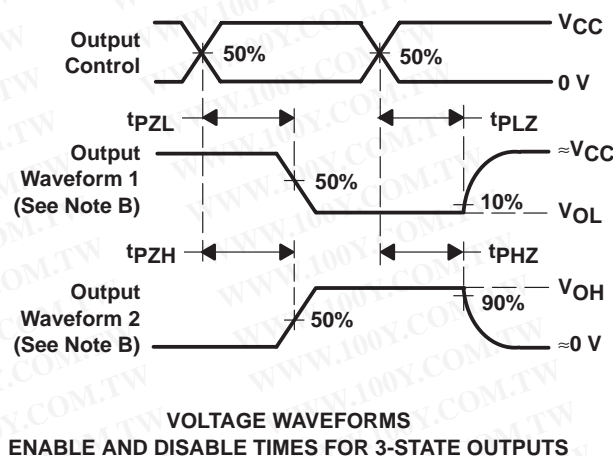
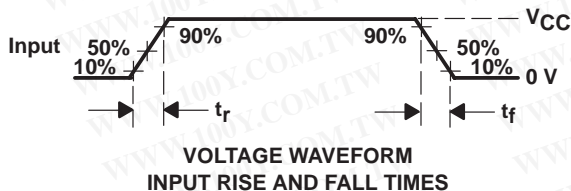
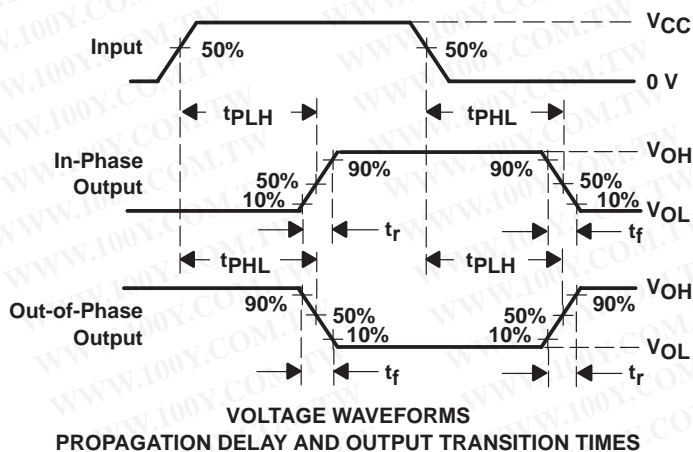

- NOTES: A. C_L includes probe and test-fixture capacitance.
 B. Waveform 1 is for an output with internal conditions such that the output is low except when disabled by the output control. Waveform 2 is for an output with internal conditions such that the output is high except when disabled by the output control.
 C. Phase relationships between waveforms were chosen arbitrarily. All input pulses are supplied by generators having the following characteristics: PRR \leq 1 MHz, $Z_O = 50 \Omega$, $t_r = 6$ ns, $t_f = 6$ ns.
 D. The outputs are measured one at a time with one input transition per measurement.
 E. t_{PLZ} and t_{PHZ} are the same as t_{dis} .
 F. t_{PZL} and t_{PZH} are the same as t_{en} .
 G. t_{PLH} and t_{PHL} are the same as t_{pd} .

Figure 1. Load Circuit and Voltage Waveforms

勝特力材料 886-3-5753170
 勝特力电子(上海) 86-21-34970699
 勝特力电子(深圳) 86-755-83298787
[Http://www.100y.com.tw](http://www.100y.com.tw)

PACKAGING INFORMATION

| Orderable Device | Status ⁽¹⁾ | Package Type | Package Drawing | Pins | Package Qty | Eco Plan ⁽²⁾ | Lead/Ball Finish | MSL Peak Temp ⁽³⁾ |
|------------------|-----------------------|--------------|-----------------|------|-------------|-------------------------|------------------|------------------------------|
| 5962-86848012A | ACTIVE | LCCC | FK | 20 | 1 | TBD | POST-PLATE | N / A for Pkg Type |
| 5962-8684801CA | ACTIVE | CDIP | J | 14 | 1 | TBD | A42 SNPB | N / A for Pkg Type |
| SN54HC126J | ACTIVE | CDIP | J | 14 | 1 | TBD | A42 SNPB | N / A for Pkg Type |
| SN74HC126D | ACTIVE | SOIC | D | 14 | 50 | Green (RoHS & no Sb/Br) | CU NIPDAU | Level-1-260C-UNLIM |
| SN74HC126DBLE | OBSOLETE | SSOP | DB | 14 | | TBD | Call TI | Call TI |
| SN74HC126DBR | ACTIVE | SSOP | DB | 14 | 2000 | Green (RoHS & no Sb/Br) | CU NIPDAU | Level-1-260C-UNLIM |
| SN74HC126DBRE4 | ACTIVE | SSOP | DB | 14 | 2000 | Green (RoHS & no Sb/Br) | CU NIPDAU | Level-1-260C-UNLIM |
| SN74HC126DBRG4 | ACTIVE | SSOP | DB | 14 | 2000 | Green (RoHS & no Sb/Br) | CU NIPDAU | Level-1-260C-UNLIM |
| SN74HC126DE4 | ACTIVE | SOIC | D | 14 | 50 | Green (RoHS & no Sb/Br) | CU NIPDAU | Level-1-260C-UNLIM |
| SN74HC126DG4 | ACTIVE | SOIC | D | 14 | 50 | Green (RoHS & no Sb/Br) | CU NIPDAU | Level-1-260C-UNLIM |
| SN74HC126DR | ACTIVE | SOIC | D | 14 | 2500 | Green (RoHS & no Sb/Br) | CU NIPDAU | Level-1-260C-UNLIM |
| SN74HC126DRE4 | ACTIVE | SOIC | D | 14 | 2500 | Green (RoHS & no Sb/Br) | CU NIPDAU | Level-1-260C-UNLIM |
| SN74HC126DRG4 | ACTIVE | SOIC | D | 14 | 2500 | Green (RoHS & no Sb/Br) | CU NIPDAU | Level-1-260C-UNLIM |
| SN74HC126DT | ACTIVE | SOIC | D | 14 | 250 | Green (RoHS & no Sb/Br) | CU NIPDAU | Level-1-260C-UNLIM |
| SN74HC126DTE4 | ACTIVE | SOIC | D | 14 | 250 | Green (RoHS & no Sb/Br) | CU NIPDAU | Level-1-260C-UNLIM |
| SN74HC126DTG4 | ACTIVE | SOIC | D | 14 | 250 | Green (RoHS & no Sb/Br) | CU NIPDAU | Level-1-260C-UNLIM |
| SN74HC126N | ACTIVE | PDIP | N | 14 | 25 | Pb-Free (RoHS) | CU NIPDAU | N / A for Pkg Type |
| SN74HC126N3 | OBSOLETE | PDIP | N | 14 | | TBD | Call TI | Call TI |
| SN74HC126NE4 | ACTIVE | PDIP | N | 14 | 25 | Pb-Free (RoHS) | CU NIPDAU | N / A for Pkg Type |
| SN74HC126NSR | ACTIVE | SO | NS | 14 | 2000 | Green (RoHS & no Sb/Br) | CU NIPDAU | Level-1-260C-UNLIM |
| SN74HC126NSRE4 | ACTIVE | SO | NS | 14 | 2000 | Green (RoHS & no Sb/Br) | CU NIPDAU | Level-1-260C-UNLIM |
| SN74HC126NSRG4 | ACTIVE | SO | NS | 14 | 2000 | Green (RoHS & no Sb/Br) | CU NIPDAU | Level-1-260C-UNLIM |
| SN74HC126PW | ACTIVE | TSSOP | PW | 14 | 90 | Green (RoHS & no Sb/Br) | CU NIPDAU | Level-1-260C-UNLIM |
| SN74HC126PWE4 | ACTIVE | TSSOP | PW | 14 | 90 | Green (RoHS & no Sb/Br) | CU NIPDAU | Level-1-260C-UNLIM |
| SN74HC126PWG4 | ACTIVE | TSSOP | PW | 14 | 90 | Green (RoHS & no Sb/Br) | CU NIPDAU | Level-1-260C-UNLIM |
| SN74HC126PWR | ACTIVE | TSSOP | PW | 14 | 2000 | Green (RoHS & no Sb/Br) | CU NIPDAU | Level-1-260C-UNLIM |
| SN74HC126PWRE4 | ACTIVE | TSSOP | PW | 14 | 2000 | Green (RoHS & no Sb/Br) | CU NIPDAU | Level-1-260C-UNLIM |

| Orderable Device | Status ⁽¹⁾ | Package Type | Package Drawing | Pins | Package Qty | Eco Plan ⁽²⁾ | Lead/Ball Finish | MSL Peak Temp ⁽³⁾ |
|------------------|-----------------------|--------------|-----------------|------|-------------|-------------------------|------------------|------------------------------|
| SN74HC126PWRG4 | ACTIVE | TSSOP | PW | 14 | 2000 | Green (RoHS & no Sb/Br) | CU NIPDAU | Level-1-260C-UNLIM |
| SN74HC126PWT | ACTIVE | TSSOP | PW | 14 | 250 | Green (RoHS & no Sb/Br) | CU NIPDAU | Level-1-260C-UNLIM |
| SN74HC126PWTE4 | ACTIVE | TSSOP | PW | 14 | 250 | Green (RoHS & no Sb/Br) | CU NIPDAU | Level-1-260C-UNLIM |
| SN74HC126PWTG4 | ACTIVE | TSSOP | PW | 14 | 250 | Green (RoHS & no Sb/Br) | CU NIPDAU | Level-1-260C-UNLIM |
| SNJ54HC126FK | ACTIVE | LCCC | FK | 20 | 1 | TBD | POST-PLATE | N / A for Pkg Type |
| SNJ54HC126J | ACTIVE | CDIP | J | 14 | 1 | TBD | A42 SNPB | N / A for Pkg Type |

⁽¹⁾ The marketing status values are defined as follows:

ACTIVE: Product device recommended for new designs.

LIFEBUY: TI has announced that the device will be discontinued, and a lifetime-buy period is in effect.

NRND: Not recommended for new designs. Device is in production to support existing customers, but TI does not recommend using this part in a new design.

PREVIEW: Device has been announced but is not in production. Samples may or may not be available.

OBSELETE: TI has discontinued the production of the device.

⁽²⁾ Eco Plan - The planned eco-friendly classification: Pb-Free (RoHS), Pb-Free (RoHS Exempt), or Green (RoHS & no Sb/Br) - please check for the latest availability information and additional product content details.

TBD: The Pb-Free/Green conversion plan has not been defined.

Pb-Free (RoHS): TI's terms "Lead-Free" or "Pb-Free" mean semiconductor products that are compatible with the current RoHS requirements for all 6 substances, including the requirement that lead not exceed 0.1% by weight in homogeneous materials. Where designed to be soldered at high temperatures, TI Pb-Free products are suitable for use in specified lead-free processes.

Pb-Free (RoHS Exempt): This component has a RoHS exemption for either 1) lead-based flip-chip solder bumps used between the die and package, or 2) lead-based die adhesive used between the die and leadframe. The component is otherwise considered Pb-Free (RoHS compatible) as defined above.

Green (RoHS & no Sb/Br): TI defines "Green" to mean Pb-Free (RoHS compatible), and free of Bromine (Br) and Antimony (Sb) based flame retardants (Br or Sb do not exceed 0.1% by weight in homogeneous material)

⁽³⁾ MSL, Peak Temp. -- The Moisture Sensitivity Level rating according to the JEDEC industry standard classifications, and peak solder temperature.

Important Information and Disclaimer:The information provided on this page represents TI's knowledge and belief as of the date that it is provided. TI bases its knowledge and belief on information provided by third parties, and makes no representation or warranty as to the accuracy of such information. Efforts are underway to better integrate information from third parties. TI has taken and continues to take reasonable steps to provide representative and accurate information but may not have conducted destructive testing or chemical analysis on incoming materials and chemicals. TI and TI suppliers consider certain information to be proprietary, and thus CAS numbers and other limited information may not be available for release.

In no event shall TI's liability arising out of such information exceed the total purchase price of the TI part(s) at issue in this document sold by TI to Customer on an annual basis.

勝特力材料 886-3-5753170
 勝特力电子(上海) 86-21-34970699
 勝特力电子(深圳) 86-755-83298787
[Http://www.100y.com.tw](http://www.100y.com.tw)

TAPE AND REEL INFORMATION

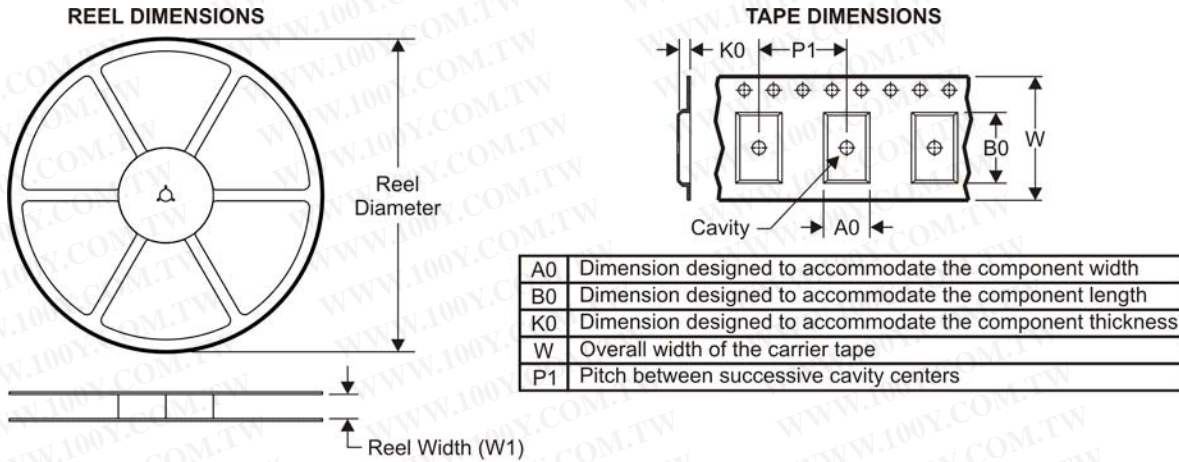

QUADRANT ASSIGNMENTS FOR PIN 1 ORIENTATION IN TAPE

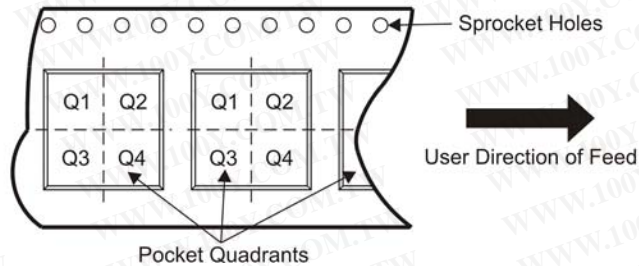

*All dimensions are nominal

| Device | Package Type | Package Drawing | Pins | SPQ | Reel Diameter (mm) | Reel Width W1 (mm) | A0 (mm) | B0 (mm) | K0 (mm) | P1 (mm) | W (mm) | Pin1 Quadrant |
|--------------|--------------|-----------------|------|------|--------------------|--------------------|---------|---------|---------|---------|--------|---------------|
| SN74HC126DBR | SSOP | DB | 14 | 2000 | 330.0 | 16.4 | 8.2 | 6.6 | 2.5 | 12.0 | 16.0 | Q1 |
| SN74HC126DR | SOIC | D | 14 | 2500 | 330.0 | 16.4 | 6.5 | 9.0 | 2.1 | 8.0 | 16.0 | Q1 |
| SN74HC126NSR | SO | NS | 14 | 2000 | 330.0 | 16.4 | 8.2 | 10.5 | 2.5 | 12.0 | 16.0 | Q1 |
| SN74HC126PWR | TSSOP | PW | 14 | 2000 | 330.0 | 12.4 | 7.0 | 5.6 | 1.6 | 8.0 | 12.0 | Q1 |

勝特力材料 886-3-5753170
勝特力电子(上海) 86-21-34970699
勝特力电子(深圳) 86-755-83298787
[Http://www.100y.com.tw](http://www.100y.com.tw)

TAPE AND REEL BOX DIMENSIONS

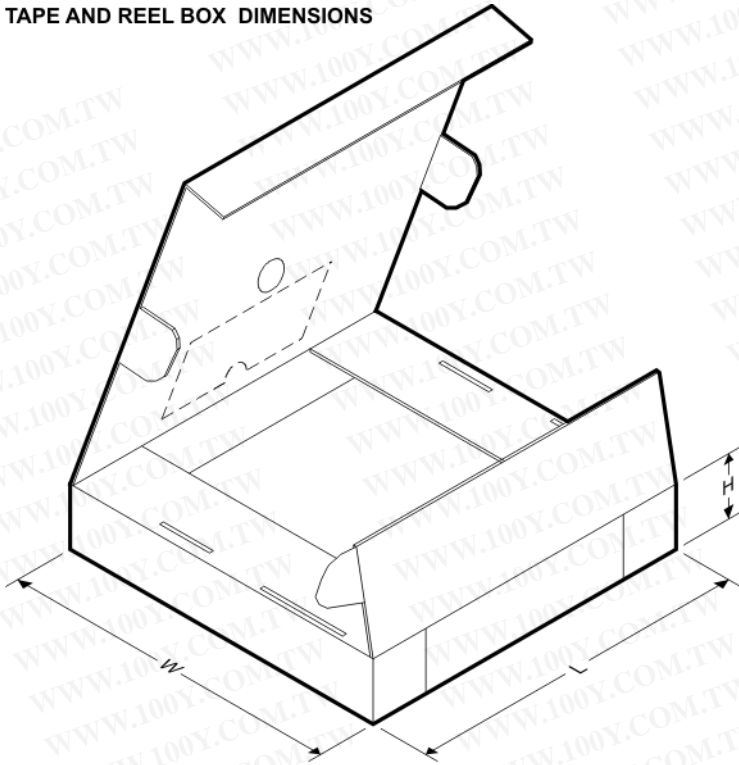

*All dimensions are nominal

| Device | Package Type | Package Drawing | Pins | SPQ | Length (mm) | Width (mm) | Height (mm) |
|--------------|--------------|-----------------|------|------|-------------|------------|-------------|
| SN74HC126DBR | SSOP | DB | 14 | 2000 | 346.0 | 346.0 | 33.0 |
| SN74HC126DR | SOIC | D | 14 | 2500 | 346.0 | 346.0 | 33.0 |
| SN74HC126NSR | SO | NS | 14 | 2000 | 346.0 | 346.0 | 33.0 |
| SN74HC126PWR | TSSOP | PW | 14 | 2000 | 346.0 | 346.0 | 29.0 |

勝特力材料 886-3-5753170
 勝特力电子(上海) 86-21-34970699
 勝特力电子(深圳) 86-755-83298787
[Http://www.100y.com.tw](http://www.100y.com.tw)

DB (R-PDSO-G**)

PLASTIC SMALL-OUTLINE

28 PINS SHOWN

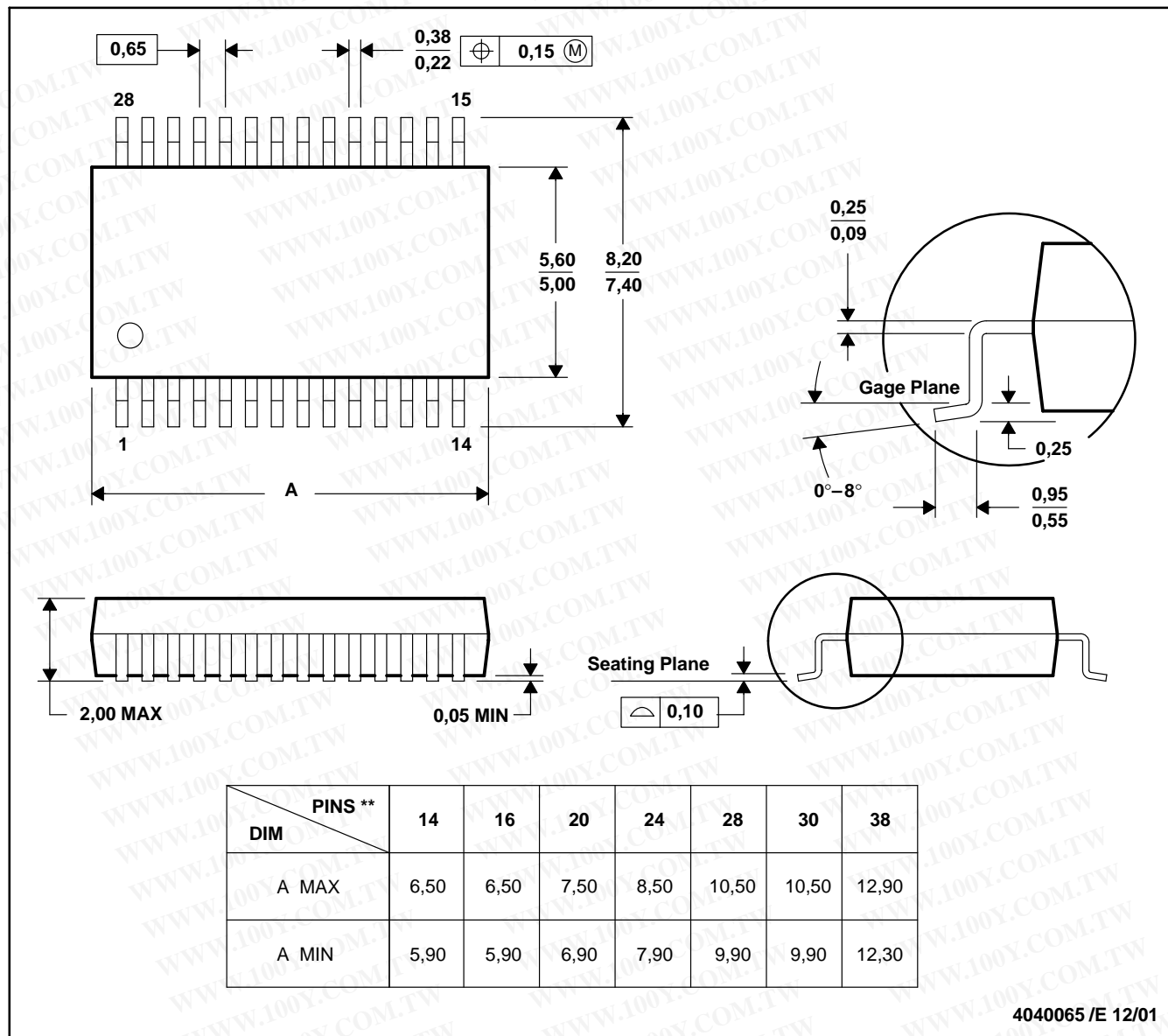

- NOTES: A. All linear dimensions are in millimeters.
 B. This drawing is subject to change without notice.
 C. Body dimensions do not include mold flash or protrusion not to exceed 0,15.
 D. Falls within JEDEC MO-150

勝特力材料 886-3-5753170
 勝特力电子(上海) 86-21-34970699
 勝特力电子(深圳) 86-755-83298787
[Http://www.100y.com.tw](http://www.100y.com.tw)

FK (S-CQCC-N**)

LEADLESS CERAMIC CHIP CARRIER

28 TERMINAL SHOWN

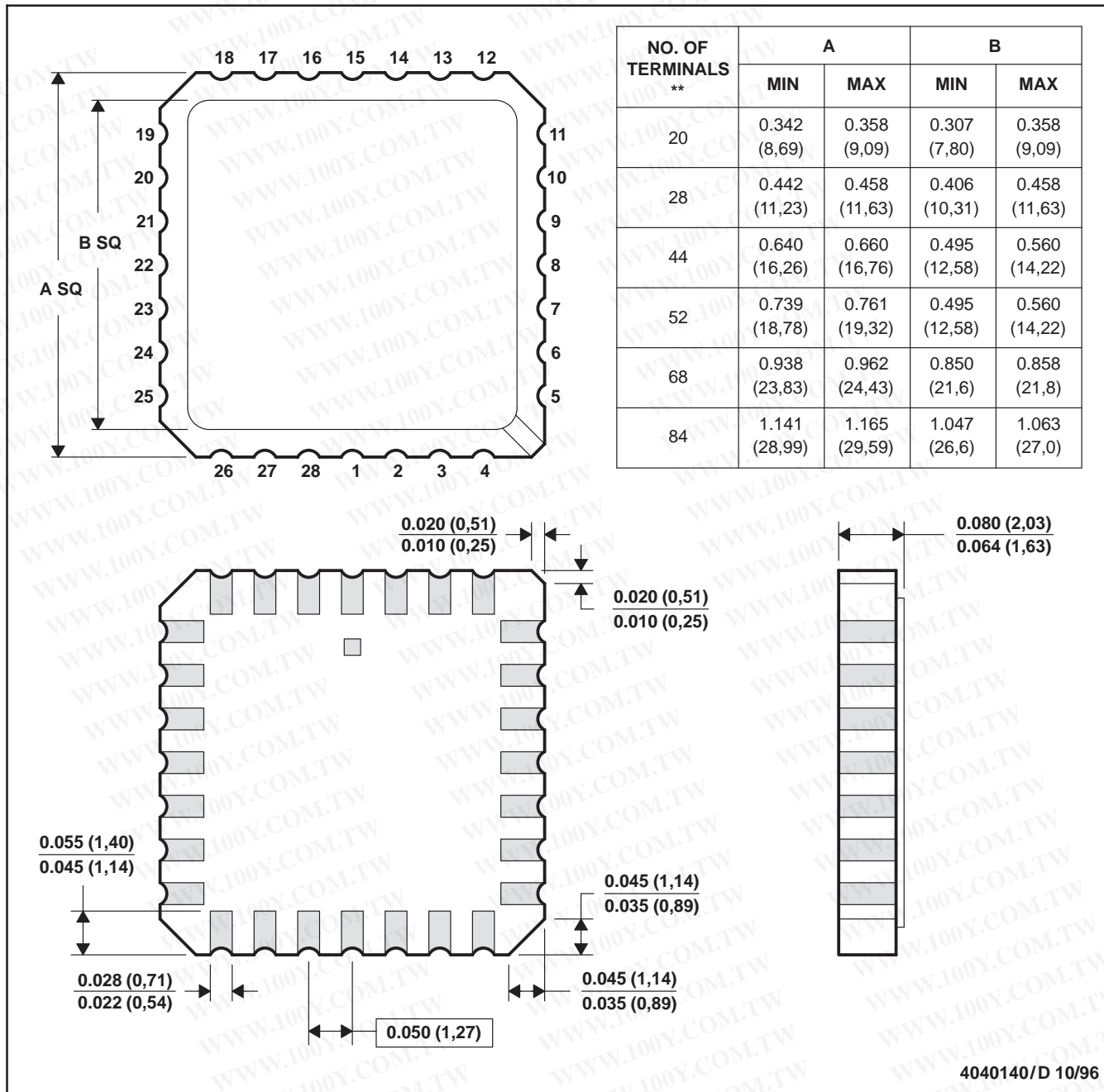

- NOTES:
- A. All linear dimensions are in inches (millimeters).
 - B. This drawing is subject to change without notice.
 - C. This package can be hermetically sealed with a metal lid.
 - D. The terminals are gold plated.
 - E. Falls within JEDEC MS-004

勝特力材料 886-3-5753170
 勝特力电子(上海) 86-21-34970699
 勝特力电子(深圳) 86-755-83298787
[Http://www.100y.com.tw](http://www.100y.com.tw)

MECHANICAL DATA

NS (R-PDSO-G**)
14-PINS SHOWN

PLASTIC SMALL-OUTLINE PACKAGE

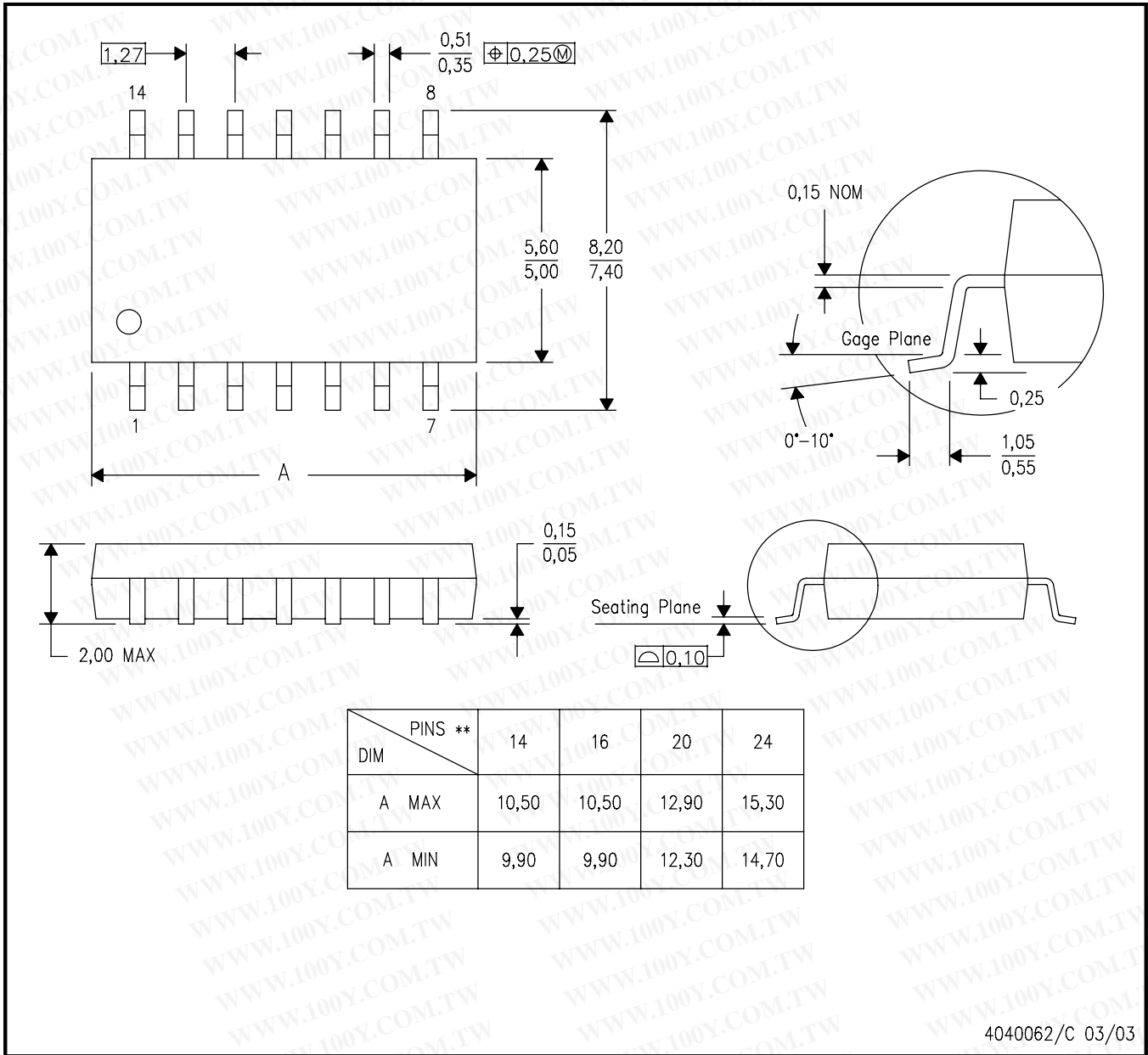

- NOTES:
- A. All linear dimensions are in millimeters.
 - B. This drawing is subject to change without notice.
 - C. Body dimensions do not include mold flash or protrusion, not to exceed 0,15.

勝特力材料 886-3-5753170
勝特力电子(上海) 86-21-34970699
勝特力电子(深圳) 86-755-83298787
[Http://www.100y.com.tw](http://www.100y.com.tw)

J (R-GDIP-T**)
 14 LEADS SHOWN

CERAMIC DUAL IN-LINE PACKAGE

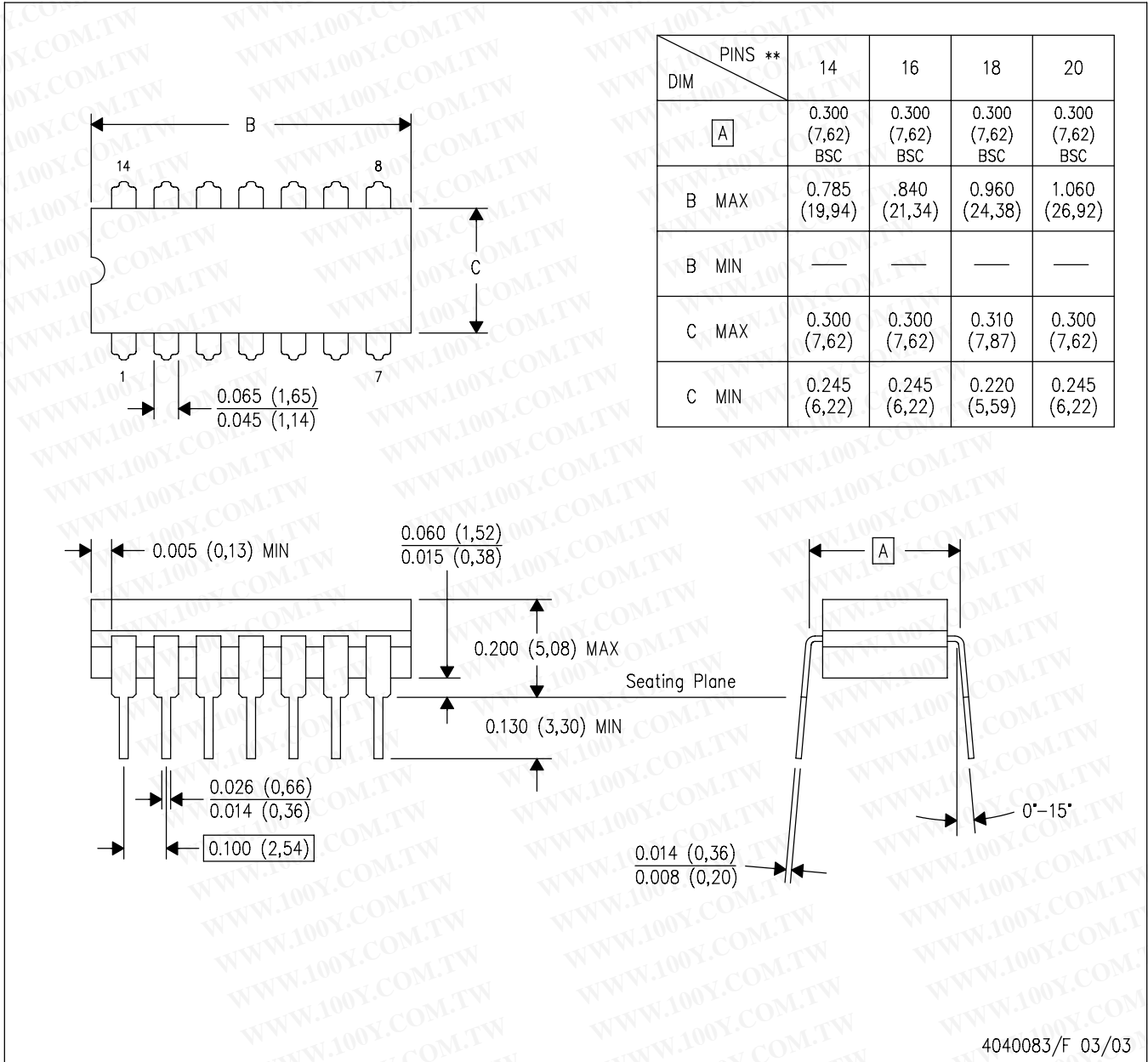

- NOTES:
- All linear dimensions are in inches (millimeters).
 - This drawing is subject to change without notice.
 - This package is hermetically sealed with a ceramic lid using glass frit.
 - Index point is provided on cap for terminal identification only on press ceramic glass frit seal only.
 - Falls within MIL STD 1835 GDIP1-T14, GDIP1-T16, GDIP1-T18 and GDIP1-T20.

PW (R-PDSO-G**)

PLASTIC SMALL-OUTLINE PACKAGE

14 PINS SHOWN

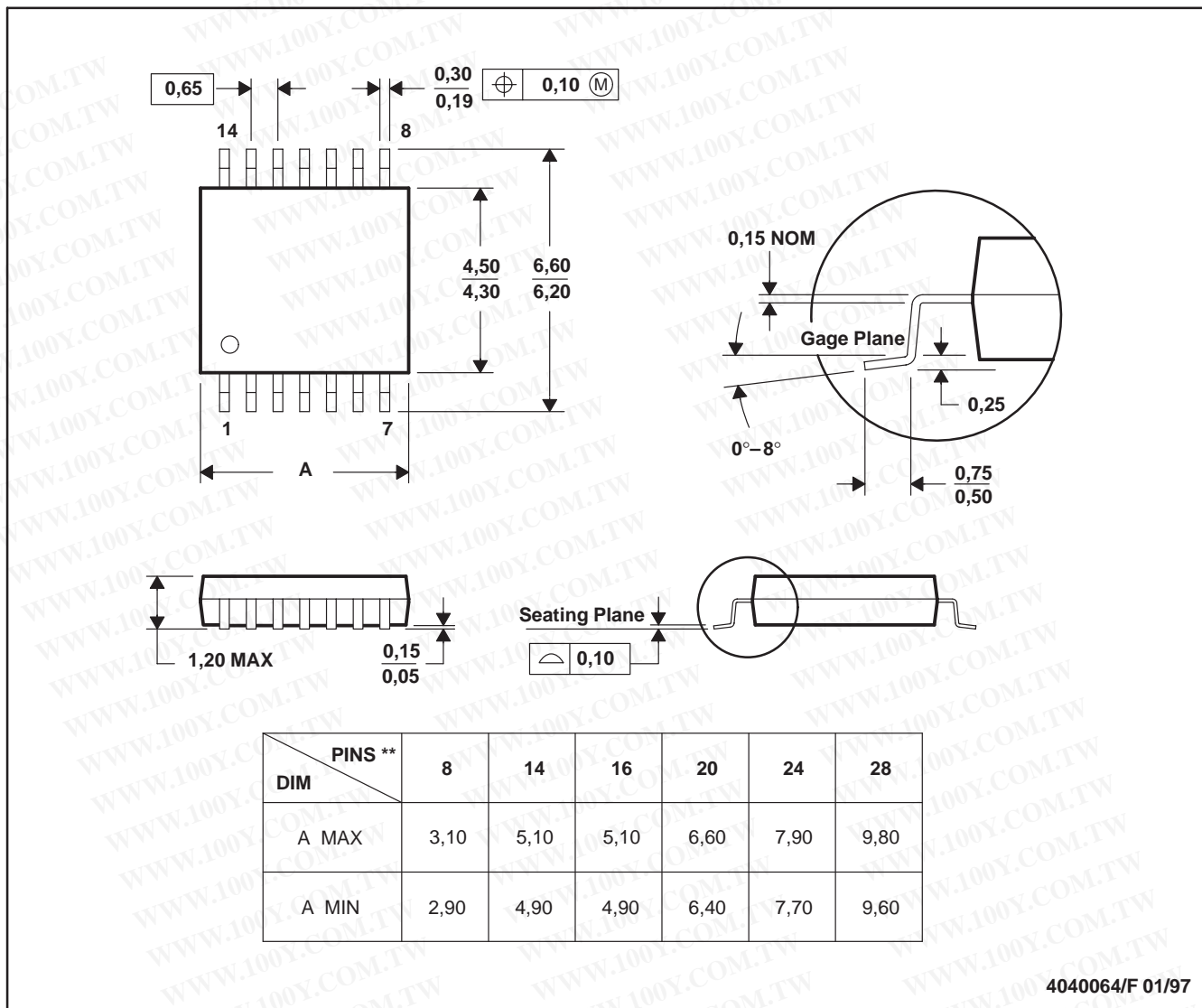

- NOTES: A. All linear dimensions are in millimeters.
 B. This drawing is subject to change without notice.
 C. Body dimensions do not include mold flash or protrusion not to exceed 0,15.
 D. Falls within JEDEC MO-153

勝特力材料 886-3-5753170
 勝特力电子(上海) 86-21-34970699
 勝特力电子(深圳) 86-755-83298787
[Http://www.100y.com.tw](http://www.100y.com.tw)

N (R-PDIP-T**)

PLASTIC DUAL-IN-LINE PACKAGE

16 PINS SHOWN

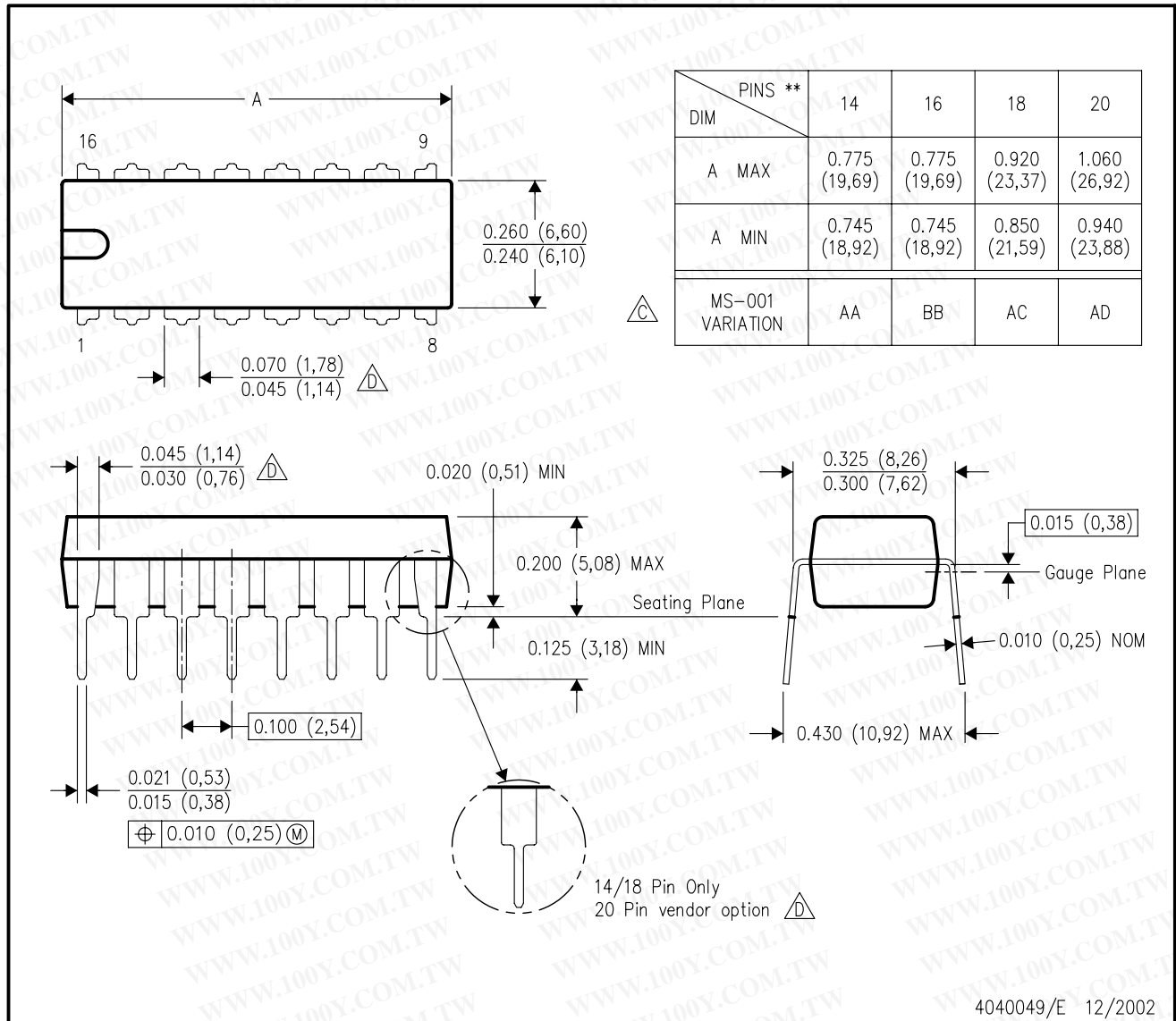

- NOTES:
- A. All linear dimensions are in inches (millimeters).
 - B. This drawing is subject to change without notice.
 - Falls within JEDEC MS-001, except 18 and 20 pin minimum body length (Dim A).
 - The 20 pin end lead shoulder width is a vendor option, either half or full width.

勝特力材料 886-3-5753170
 胜特力电子(上海) 86-21-34970699
 胜特力电子(深圳) 86-755-83298787
[Http://www.100y.com.tw](http://www.100y.com.tw)