

High-Speed CMOS Logic 8-Bit Universal Shift Register; Three-State

Features

- Buffered Inputs
- Four Operating Modes: Shift Left, Shift Right, Load and Store
- Can be Cascaded for N-Bit Word Lengths
- I/O₀ - I/O₇ Bus Drive Capability and Three-State for Bus Oriented Applications
- Typical f_{MAX} = 50MHz at V_{CC} = 5V, C_L = 15pF, T_A = 25°C
- Fanout (Over Temperature Range)
 - Standard Outputs 10 LSTTL Loads
 - Bus Driver Outputs 15 LSTTL Loads
- Wide Operating Temperature Range . . . -55°C to 125°C
- Balanced Propagation Delay and Transition Times
- Significant Power Reduction Compared to LSTTL Logic ICs
- HC Types
 - 2V to 6V Operation
 - High Noise Immunity: N_{IL} = 30%, N_{IH} = 30% of V_{CC} at V_{CC} = 5V
- HCT Types
 - 4.5V to 5.5V Operation
 - Direct LSTTL Input Logic Compatibility, V_{IL} = 0.8V (Max), V_{IH} = 2V (Min)
 - CMOS Input Compatibility, I_I ≤ 1μA at V_{OL}, V_{OH}

Description

The 'HC259 and 'HCT299 are 8-bit shift/storage registers with three-state bus interface capability. The register has four synchronous-operating modes controlled by the two select inputs as shown in the mode select (S₀, S₁) table. The mode select, the serial data (DS₀, DS₇) and the parallel data (I/O₀ - I/O₇) respond only to the low-to-high transition of the clock (CP) pulse. S₀, S₁ and data inputs must be stable one set-up time prior to the clock positive transition.

The Master Reset (\overline{MR}) is an asynchronous active low input. When \overline{MR} output is low, the register is cleared regardless of the status of all other inputs. The register can be expanded by cascading same units by tying the serial output (Q₀) to the serial data (DS₇) input of the preceding register, and tying the serial output (Q₇) to the serial data (DS₀) input of the following register. Recirculating the (n x 8) bits is accomplished by tying the Q₇ of the last stage to the DS₀ of the first stage.

The three-state input/output I(I/O) port has three modes of operation:

1. Both output enable ($\overline{OE1}$ and $\overline{OE2}$) inputs are low and S₀ or S₁ or both are low, the data in the register is presented at the eight outputs.
2. When both S₀ and S₁ are high, I/O terminals are in the high impedance state but being input ports, ready for parallel data to be loaded into eight registers with one clock transition regardless of the status of $\overline{OE1}$ and $\overline{OE2}$.
3. Either one of the two output enable inputs being high will force I/O terminals to be in the off-state. It is noted that each I/O terminal is a three-state output and a CMOS buffer input.

Pinout

CD54HC299, CD54HCT299
 (CERDIP)
 CD74HC299, CD74HCT299
 (PDIP, SOIC)
 TOP VIEW

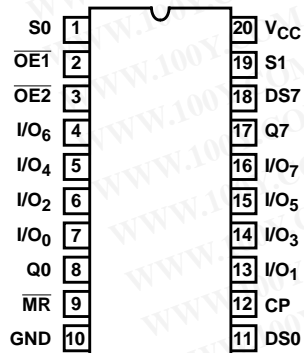

Ordering Information

PART NUMBER	TEMP. RANGE (°C)	PACKAGE
CD54HC299F3A	-55 to 125	20 Ld CERDIP
CD54HCT299F3A	-55 to 125	20 Ld CERDIP
CD74HC299E	-55 to 125	20 Ld PDIP
CD74HC299M	-55 to 125	20 Ld SOIC
CD74HC299M96	-55 to 125	20 Ld SOIC
CD74HCT299E	-55 to 125	20 Ld PDIP
CD74HCT299M	-55 to 125	20 Ld SOIC
CD74HCT299M96	-55 to 125	20 Ld SOIC

NOTE: When ordering, use the entire part number. The suffix 96 denotes tape and reel.

Functional Diagram

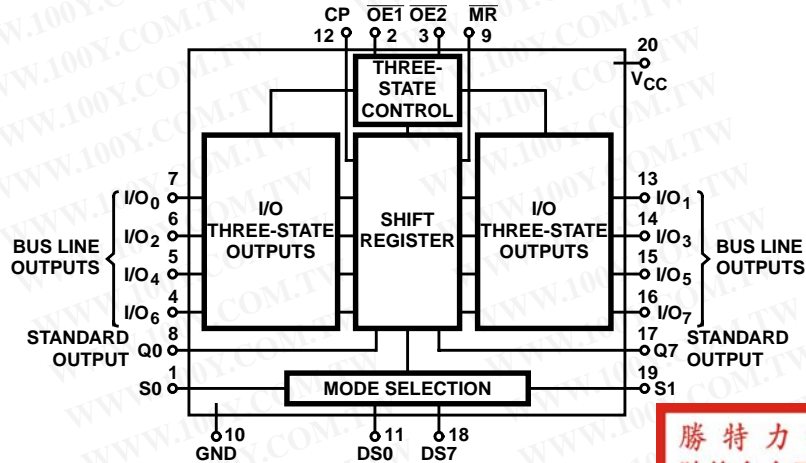

勝特力材料 886-3-5753170
 勝特力电子(上海) 86-21-34970699
 勝特力电子(深圳) 86-755-83298787
[Http://www.100y.com.tw](http://www.100y.com.tw)

MODE SELECT FUNCTION TABLE THREE-STATE I/O PORT OPERATING MODE

FUNCTION	INPUTS				INPUTS/OUTPUTS	
	OE1	OE2	S0	S1	Qn (REGISTER)	I/O0 --- I/O7
Read Register	L	L	L	X	L	L
	L	L	L	X	H	H
	L	L	X	L	L	L
	L	L	X	L	H	H
Load Register	X	X	H	H	Qn = I/On	I/On = Inputs
Disable I/O	H	X	X	X	X	(Z)
	X	H	X	X	X	(Z)

TRUTH TABLE

FUNCTION	INPUTS							REGISTER OUTPUTS				
	MR	CP	S0	S1	DS0	DS7	I/On	Q0	Q1	---	Q6	Q7
RESET (CLEAR)	L	X	X	X	X	X	X	L	L	---	L	L
Shift Right	H	↑	h	l	l	X	X	L	q0	---	q5	q6
	H	↑	h	l	h	X	X	H	q0	---	q5	Q6
Shift Left	H	↑	l	h	X	l	X	q1	q2	---	q7	L
	H	↑	l	h	X	h	X	q1	q2	---	q7	H
Hold (Do Nothing)	H	↑	l	l	X	X	X	q0	q1	---	q6	q7
Parallel Load	H	↑	h	h	X	X	l	L	L	---	L	L
	H	↑	h	h	X	X	h	H	H	---	H	H

H = Input Voltage High Level, h = Input voltage high one set-up timer prior clock transition; L = Input Voltage Low Level; l = Input voltage low one set-up time prior to clock transition; qn = Lower case letter indicates the state of the reference output one set-up time prior to clock transition; X - Voltage level on logic status don't care; Z = Output in high impedance state, ↑ = Low to High Clock Transition.

CD54HC299, CD74HC299, CD54HCT299, CD74HCT299

Absolute Maximum Ratings

DC Supply Voltage, V_{CC}	-0.5V to 7V
DC Input Diode Current, I_{IK}	
For $V_I < -0.5V$ or $V_I > V_{CC} + 0.5V$	$\pm 20mA$
DC Output Diode Current, I_{OK}	
For $V_O < -0.5V$ or $V_O > V_{CC} + 0.5V$	$\pm 20mA$
DC Drain Current, per Output, I_O , For $-0.5V < V_O < V_{CC} + 0.5V$	
For Q Outputs	$\pm 25mA$
For I/O Outputs	$\pm 35mA$
DC Output Source or Sink Current per Output Pin, I_O	
For $V_O > -0.5V$ or $V_O < V_{CC} + 0.5V$	$\pm 25mA$
DC V_{CC} or Ground Current, I_{CC}	$\pm 50mA$

Operating Conditions

Temperature Range, T_A	-55°C to 125°C
Supply Voltage Range, V_{CC}	
HC Types2V to 6V
HCT Types4.5V to 5.5V
DC Input or Output Voltage, V_I, V_O	0V to V_{CC}
Input Rise and Fall Time	
2V	1000ns (Max)
4.5V	500ns (Max)
6V	400ns (Max)

Thermal Information

Thermal Resistance (Typical, Note 1)	θ_{JA} (°C/W)
E (PDIP) Package	69
M (SOIC) Package	58
Maximum Junction Temperature	150°C
Maximum Storage Temperature Range	-65°C to 150°C
Maximum Lead Temperature (Soldering 10s)	300°C
(SOIC - Lead Tips Only)	

勝特力材料 886-3-5753170
 勝特力电子(上海) 86-21-34970699
 勝特力电子(深圳) 86-755-83298787
[Http://www.100y.com.tw](http://www.100y.com.tw)

CAUTION: Stresses above those listed in "Absolute Maximum Ratings" may cause permanent damage to the device. This is a stress only rating and operation of the device at these or any other conditions above those indicated in the operational sections of this specification is not implied.

NOTE:

- The package thermal impedance is calculated in accordance with JESD 51-7.

DC Electrical Specifications

PARAMETER	SYMBOL	TEST CONDITIONS		V_{CC} (V)	25°C			-40°C TO 85°C		-55°C TO 125°C		UNITS		
		V_I (V)	I_O (mA)		MIN	TYP	MAX	MIN	MAX	MIN	MAX			
HC TYPES														
High Level Input Voltage	V_{IH}	-	-	2	1.5	-	-	1.5	-	1.5	-	V		
				4.5	3.15	-	-	3.15	-	3.15	-	V		
				6	4.2	-	-	4.2	-	4.2	-	V		
Low Level Input Voltage	V_{IL}	-	-	2	-	-	0.5	-	0.5	-	0.5	V		
				4.5	-	-	1.35	-	1.35	-	1.35	V		
				6	-	-	1.8	-	1.8	-	1.8	V		
High Level Output Voltage CMOS Loads	V_{OH}	V_{IH} or V_{IL}	-0.02	2	1.9	-	-	1.9	-	1.9	-	V		
				4.5	4.4	-	-	4.4	-	4.4	-	V		
				6	5.9	-	-	5.9	-	5.9	-	V		
High Level Output Voltage TTL Loads	V_{OH}	V_{IH} or V_{IL}	-0.02	Qn	I/On	-	-	-	-	-	-	V		
				-4	-6	4.5	3.98	-	-	3.84	-	3.7	-	V
				-5.2	-7.8	6	5.48	-	-	5.34	-	5.2	-	V
Low Level Output Voltage CMOS Loads	V_{OL}	V_{IH} or V_{IL}	0.02	2	-	-	0.1	-	0.1	-	0.1	V		
				4.5	-	-	0.1	-	0.1	-	0.1	V		
				6	-	-	0.1	-	0.1	-	0.1	V		
Low Level Output Voltage TTL Loads	V_{OL}	V_{IH} or V_{IL}	0.02	Qn	I/On	-	-	-	-	-	-	V		
				4	6	4.5	-	-	0.26	-	0.33	-	0.4	V
				5.2	7.8	6	-	-	0.26	-	0.33	-	0.4	V
Input Leakage Current	I_I	V_{CC} or GND	-	6	-	-	± 0.1	-	± 1	-	± 1	μA		

CD54HC299, CD74HC299, CD54HCT299, CD74HCT299

DC Electrical Specifications (Continued)

PARAMETER	SYMBOL	TEST CONDITIONS		V _{CC} (V)	25°C			-40°C TO 85°C		-55°C TO 125°C		UNITS
		V _I (V)	I _O (mA)		MIN	TYP	MAX	MIN	MAX	MIN	MAX	
Quiescent Device Current	I _{CC}	V _{CC} or GND	0	6	-	-	8	-	80	-	160	μA
Three- State Leakage Current	V _{IL} or V _{IH}	V _O = V _{CC} or GND	-	6	-	-	±0.5	-	±5	-	±10	μA
HCT TYPES												
High Level Input Voltage	V _{IH}	-	-	4.5 to 5.5	2	-	-	2	-	2	-	V
Low Level Input Voltage	V _{IL}	-	-	4.5 to 5.5	-	-	0.8	-	0.8	-	0.8	V
High Level Output Voltage CMOS Loads	V _{OH}	V _{IH} or V _{IL}	-0.02	4.5	4.4	-	-	4.4	-	4.4	-	V
High Level Output Voltage TTL Loads			-4	4.5	3.98	-	-	3.84	-	3.7	-	V
Low Level Output Voltage CMOS Loads	V _{OL}	V _{IH} or V _{IL}	0.02	4.5	-	-	0.1	-	0.1	-	0.1	V
Low Level Output Voltage TTL Loads			4	4.5	-	-	0.26	-	0.33	-	0.4	V
Input Leakage Current	I _I	V _{CC} and GND	0	5.5	-	-	±0.1	-	±1	-	±1	μA
Quiescent Device Current	I _{CC}	V _{CC} or GND	0	5.5	-	-	8	-	80	-	160	μA
Three- State Leakage Current	V _{IL} or V _{IH}	V _O = V _{CC} or GND	-	6	-	-	±0.5	-	±5	-	±10	μA
Additional Quiescent Device Current Per Input Pin: 1 Unit Load	ΔI _{CC} (Note 2)	V _{CC} -2.1	-	4.5 to 5.5	-	100	360	-	450	-	490	μA

NOTE:

- For dual-supply systems theoretical worst case (V_I = 2.4V, V_{CC} = 5.5V) specification is 1.8mA.

HCT Input Loading Table

INPUT	UNIT LOADS
S1, MR	0.25
I/O ₀ - I/O ₇	0.25
DS0, DS7	0.25
S0, CP	0.6
OE1, OE2	0.3

NOTE: Unit Load is ΔI_{CC} limit specific in Static Specifications Table, e.g., 360μA max. at 25°C.

CD54HC299, CD74HC299, CD54HCT299, CD74HCT299

Prerequisite for Switching Specifications

PARAMETER	SYMBOL	V _{CC} (V)	25°C			-40°C TO 85°C			-55°C TO 125°C			UNITS
			MIN	TYP	MAX	MIN	TYP	MAX	MIN	TYP	MAX	
HC TYPES												
Maximum Clock Frequency	f _{MAX}	2	6	-	-	5	-	-	4	-	-	MHz
		4.5	30	-	-	25	-	-	20	-	-	MHz
		6	35	-	-	29	-	-	23	-	-	MHz
MR Pulse Width	t _W	2	50	-	-	65	-	-	75	-	-	ns
		4.5	10	-	-	13	-	-	15	-	-	ns
		6	9	-	-	11	-	-	13	-	-	ns
Clock Pulse Width	t _W	2	80	-	-	100	-	-	120	-	-	ns
		4.5	16	-	-	20	-	-	24	-	-	ns
		6	14	-	-	17	-	-	20	-	-	ns
Setup Time DS0, DS7, I/On to Clock	t _{SU}	2	100	-	-	125	-	-	150	-	-	ns
		4.5	20	-	-	25	-	-	30	-	-	ns
		6	17	-	-	21	-	-	26	-	-	ns
Hold Time DS0, DS7, I/On, S0, S1 to Clock	t _H	2	0	-	-	0	-	-	0	-	-	ns
		4.5	0	-	-	0	-	-	0	-	-	ns
		6	0	-	-	0	-	-	0	-	-	ns
Recovery Time MR to Clock	t _{REC}	2	5	-	-	5	-	-	5	-	-	ns
		4.5	5	-	-	5	-	-	5	-	-	ns
		6	5	-	-	5	-	-	5	-	-	ns
Setup Time S1, S0 to Clock	t _{SU}	2	120	-	-	150	-	-	180	-	-	ns
		4.5	24	-	-	30	-	-	36	-	-	ns
		6	20	-	-	26	-	-	31	-	-	ns
HCT TYPES												
Maximum Clock Frequency	f _{MAX}	4.5	25	-	-	20	-	-	16	-	-	MHz
MR Pulse Width	t _W	4.5	15	-	-	19	-	-	22	-	-	ns
Clock Pulse Width	t _W	4.5	20	-	-	25	-	-	30	-	-	ns
Setup Time DS0, DS7, I/On, S0, S1 to Clock	t _{SU}	4.5	20	-	-	25	-	-	30	-	-	ns
Hold Time DS0, DS7, I/On, S0, S1 to Clock	t _H	4.5	0	-	-	0	-	-	0	-	-	ns
Recovery Time MR to Clock	t _{REC}	4.5	5	-	-	5	-	-	5	-	-	ns
Setup Time S1, S0 to Clock	t _{SU}	4.5	27	-	-	34	-	-	41	-	-	ns

CD54HC299, CD74HC299, CD54HCT299, CD74HCT299

Switching Specifications $C_L = 50\text{pF}$, Input $t_r, t_f = 6\text{ns}$

PARAMETER	SYMBOL	TEST CONDITIONS	V_{CC} (V)	25°C			-40°C TO 85°C		-55°C TO 125°C		UNITS
				MIN	TYP	MAX	MIN	MAX	MIN	MAX	
HC TYPES											
Propagation Delay Clock to I/O Output, Clock to Q0 and Q7, MR to Output	t_{PLH}, t_{PHL}	$C_L = 50\text{pF}$	2	-	-	200	-	250	-	300	ns
			4.5	-	-	40	-	50	-	60	ns
		$C_L = 15\text{pF}$	5	-	17	-	-	-	-	-	ns
		$C_L = 50\text{pF}$	6	-	-	34	-	43	-	51	ns
Output Enable and Disable Times	t_{PZL} t_{PZH}, t_{PLZ} t_{PHZ}	$C_L = 15\text{pF}$	5	-	10	-	-	-	-	-	ns
			-	-	13	-	-	-	-	-	ns
			-	-	15	-	-	-	-	-	ns
Output High-Z to High Level	t_{PZH}	$C_L = 50\text{pF}$	2	-	-	155	-	195	-	235	ns
			4.5	-	-	31	-	39	-	47	ns
			6	-	-	26	-	33	-	40	ns
Output High Level to High-Z	t_{PHZ}	$C_L = 50\text{pF}$	2	-	-	185	-	230	-	280	ns
			4.5	-	-	37	-	46	-	56	ns
			6	-	-	31	-	39	-	48	ns
Output Low Level to High-Z	t_{PLZ}	$C_L = 50\text{pF}$	2	-	-	155	-	195	-	235	ns
			4.5	-	-	31	-	39	-	47	ns
			6	-	-	26	-	33	-	40	ns
Output High-Z to Low Level	t_{PZL}	$C_L = 50\text{pF}$	2	-	-	130	-	165	-	195	ns
			4.5	-	-	26	-	33	-	39	ns
			6	-	-	22	-	28	-	33	ns
Output Transition Time Q0, Q7	t_{THL}, t_{TLH}	$C_L = 50\text{pF}$	2	-	-	75	-	95	-	110	ns
			4.5	-	-	15	-	19	-	22	ns
			6	-	-	13	-	16	-	19	ns
I/O ₀ to I/O ₇	t_{THL}, t_{TLH}	$C_L = 50\text{pF}$	2	-	-	60	-	75	-	90	ns
			4.5	-	-	12	-	15	-	18	ns
			6	-	-	10	-	13	-	15	ns
Input Capacitance	C_I	$C_L = 50\text{pF}$	-	10	-	10	-	10	-	10	pF
Three-State Output Capacitance	C_O	-	-	20	-	20	-	20	-	20	pF
Power Dissipation Capacitance (Notes 3, 4)	C_{PD}	$C_L = 15\text{pF}$	5	-	150	-	-	-	-	-	pF

CD54HC299, CD74HC299, CD54HCT299, CD74HCT299

Switching Specifications $C_L = 50\text{pF}$, Input $t_r, t_f = 6\text{ns}$ (Continued)

PARAMETER	SYMBOL	TEST CONDITIONS	V_{CC} (V)	25°C			-40°C TO 85°C		-55°C TO 125°C		UNITS
				MIN	TYP	MAX	MIN	MAX	MIN	MAX	
HCT TYPES											
Propagation Delay Clock to I/O Output, Clock to Q0 and Q7	t_{PHL}, t_{PLH}	$C_L = 50\text{pF}$	4.5	-	-	45	-	56	-	68	ns
		$C_L = 15\text{pF}$	5	-	19	-	-	-	-	-	ns
$\overline{\text{MR}}$ to Output	t_{PHL}, t_{PLH}	$C_L = 50\text{pF}$	4.5	-	-	46	-	58	-	69	ns
Output Enable and Disable Times	$t_{PZL}, t_{PZH}, t_{PLZ}, t_{PHZ}$	$C_L = 15\text{pF}$	5	-	10, 13, 15	-	-	-	-	-	ns
Output High-Z to High Level	t_{PZH}	$C_L = 50\text{pF}$	4.5	-	-	32	-	40	-	48	ns
Output High Level to High-Z	t_{PHZ}	$C_L = 50\text{pF}$	4.5	-	-	37	-	46	-	56	ns
Output Low Level to High-Z	t_{PLZ}	$C_L = 50\text{pF}$	4.5	-	-	32	-	40	-	48	ns
Output High-Z to Low Level	t_{PZL}	$C_L = 50\text{pF}$	4.5	-	-	30	-	38	-	45	ns
Output Transition Time Q0, Q7	t_{TLH}, t_{THL}	$C_L = 50\text{pF}$	4.5	-	-	15	-	19	-	22	ns
I/O0 to I/O7		$C_L = 50\text{pF}$	4.5	-	-	12	-	15	-	18	ns
Input Capacitance	C_{IN}	$C_L = 50\text{pF}$	-	10	-	10	-	10	-	10	pF
Three-State Output Capacitance	C_O	-	-	20	-	20	-	20	-	20	pF
Power Dissipation Capacitance (Notes 3, 4)	C_{PD}	$C_L = 15\text{pF}$	5	-	170	-	-	-	-	-	pF

NOTES:

- C_{PD} is used to determine the dynamic power consumption, per register.
- $P_D = C_{PD} V_{CC}^2 f_i + \sum (C_L V_{CC}^2 f_O)$ where f_i = Input Frequency, f_O = Output Frequency, C_L = Output Load Capacitance, V_{CC} = Supply Voltage.

Test Circuits and Waveforms

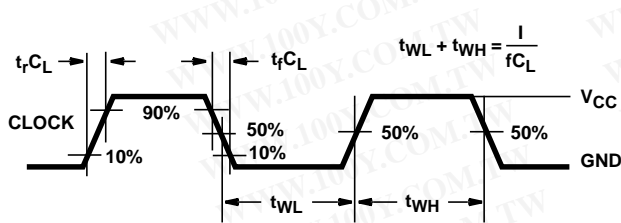

NOTE: Outputs should be switching from 10% V_{CC} to 90% V_{CC} in accordance with device truth table. For f_{MAX} , input duty cycle = 50%.

FIGURE 1. HC CLOCK PULSE RISE AND FALL TIMES AND PULSE WIDTH

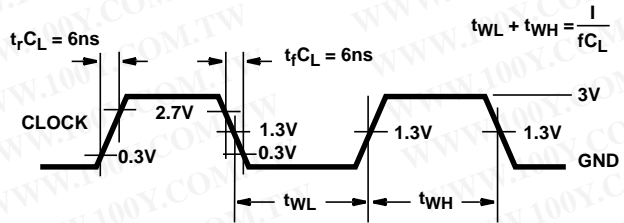

NOTE: Outputs should be switching from 10% V_{CC} to 90% V_{CC} in accordance with device truth table. For f_{MAX} , input duty cycle = 50%.

FIGURE 2. HCT CLOCK PULSE RISE AND FALL TIMES AND PULSE WIDTH

Test Circuits and Waveforms (Continued)

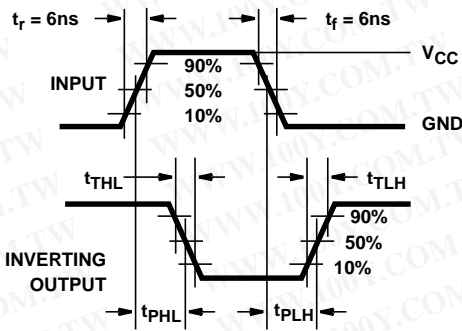

FIGURE 3. HC TRANSITION TIMES AND PROPAGATION DELAY TIMES, COMBINATION LOGIC

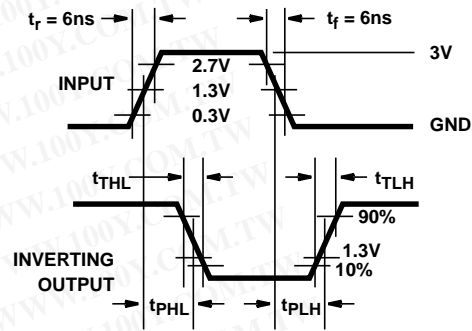

FIGURE 4. HCT TRANSITION TIMES AND PROPAGATION DELAY TIMES, COMBINATION LOGIC

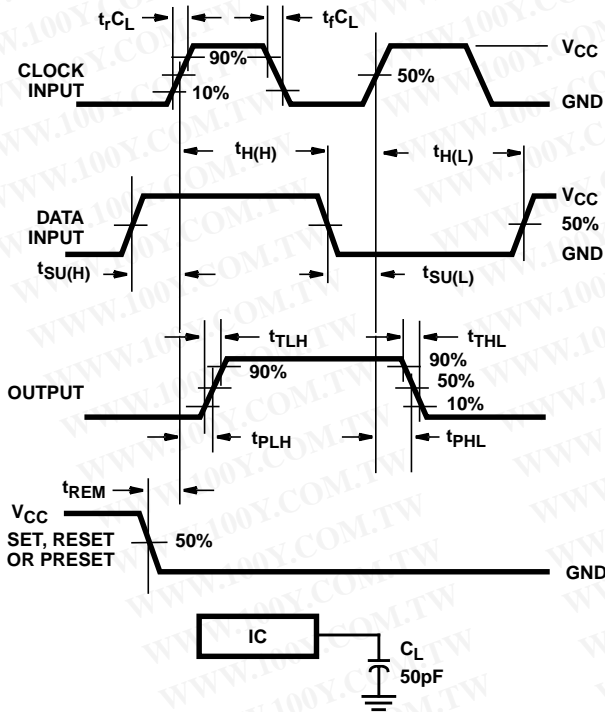

FIGURE 5. HC SETUP TIMES, HOLD TIMES, REMOVAL TIME, AND PROPAGATION DELAY TIMES FOR EDGE TRIGGERED SEQUENTIAL LOGIC CIRCUITS

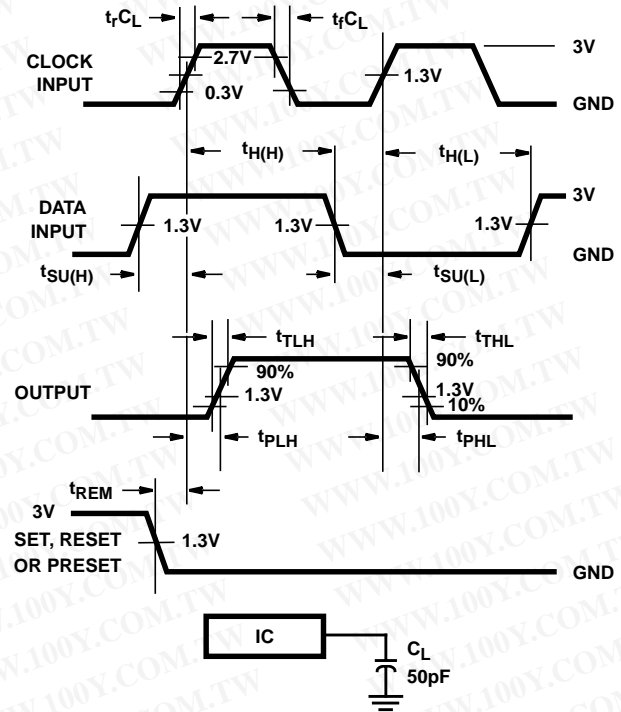

FIGURE 6. HCT SETUP TIMES, HOLD TIMES, REMOVAL TIME, AND PROPAGATION DELAY TIMES FOR EDGE TRIGGERED SEQUENTIAL LOGIC CIRCUITS

Test Circuits and Waveforms (Continued)

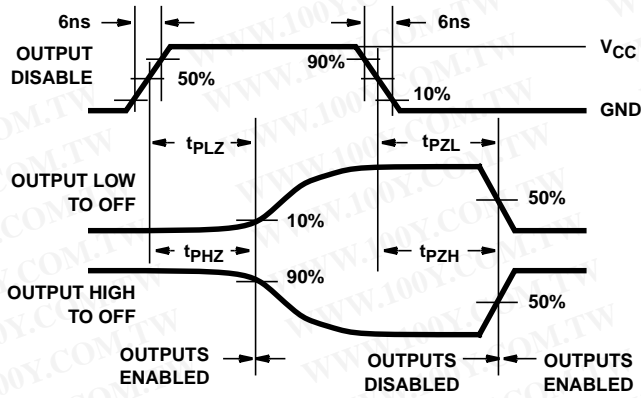

FIGURE 7. HC THREE-STATE PROPAGATION DELAY WAVEFORM

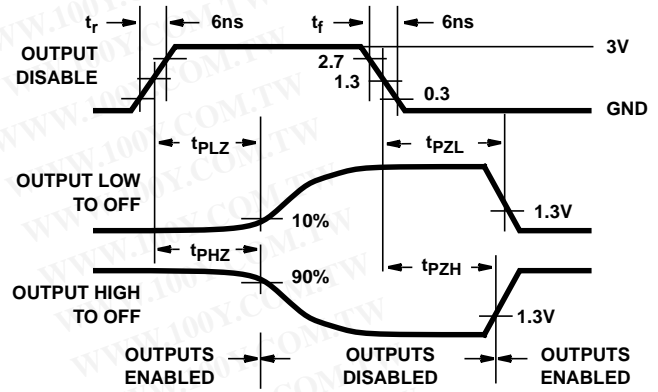
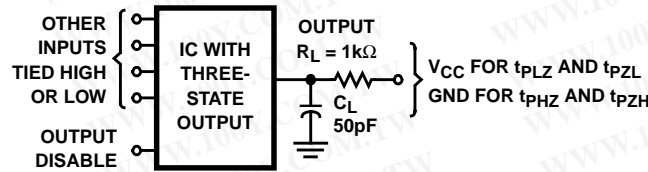

FIGURE 8. HCT THREE-STATE PROPAGATION DELAY WAVEFORM



NOTE: Open drain waveforms t_{pLZ} and t_{pZL} are the same as those for three-state shown on the left. The test circuit is Output $R_L = 1k\Omega$ to V_{CC} , $C_L = 50pF$.

FIGURE 9. HC AND HCT THREE-STATE PROPAGATION DELAY TEST CIRCUIT

PACKAGING INFORMATION

Orderable Device	Status ⁽¹⁾	Package Type	Package Drawing	Pins	Package Qty	Eco Plan ⁽²⁾	Lead/Ball Finish	MSL Peak Temp ⁽³⁾
5962-8780601RA	ACTIVE	CDIP	J	20	1	TBD	A42	N / A for Pkg Type
5962-8943601MRA	ACTIVE	CDIP	J	20	1	TBD	A42	N / A for Pkg Type
CD54HC299F	ACTIVE	CDIP	J	20	1	TBD	A42	N / A for Pkg Type
CD54HC299F3A	ACTIVE	CDIP	J	20	1	TBD	A42	N / A for Pkg Type
CD54HCT299F3A	ACTIVE	CDIP	J	20	1	TBD	A42	N / A for Pkg Type
CD74HC299E	ACTIVE	PDIP	N	20	20	Pb-Free (RoHS)	CU NIPDAU	N / A for Pkg Type
CD74HC299EE4	ACTIVE	PDIP	N	20	20	Pb-Free (RoHS)	CU NIPDAU	N / A for Pkg Type
CD74HC299M	ACTIVE	SOIC	DW	20	25	Green (RoHS & no Sb/Br)	CU NIPDAU	Level-1-260C-UNLIM
CD74HC299M96	ACTIVE	SOIC	DW	20	2000	Green (RoHS & no Sb/Br)	CU NIPDAU	Level-1-260C-UNLIM
CD74HC299M96E4	ACTIVE	SOIC	DW	20	2000	Green (RoHS & no Sb/Br)	CU NIPDAU	Level-1-260C-UNLIM
CD74HC299M96G4	ACTIVE	SOIC	DW	20	2000	Green (RoHS & no Sb/Br)	CU NIPDAU	Level-1-260C-UNLIM
CD74HC299ME4	ACTIVE	SOIC	DW	20	25	Green (RoHS & no Sb/Br)	CU NIPDAU	Level-1-260C-UNLIM
CD74HC299MG4	ACTIVE	SOIC	DW	20	25	Green (RoHS & no Sb/Br)	CU NIPDAU	Level-1-260C-UNLIM
CD74HCT299E	ACTIVE	PDIP	N	20	20	Pb-Free (RoHS)	CU NIPDAU	N / A for Pkg Type
CD74HCT299EE4	ACTIVE	PDIP	N	20	20	Pb-Free (RoHS)	CU NIPDAU	N / A for Pkg Type
CD74HCT299M	ACTIVE	SOIC	DW	20	25	Green (RoHS & no Sb/Br)	CU NIPDAU	Level-1-260C-UNLIM
CD74HCT299M96	ACTIVE	SOIC	DW	20	2000	Green (RoHS & no Sb/Br)	CU NIPDAU	Level-1-260C-UNLIM
CD74HCT299M96E4	ACTIVE	SOIC	DW	20	2000	Green (RoHS & no Sb/Br)	CU NIPDAU	Level-1-260C-UNLIM
CD74HCT299M96G4	ACTIVE	SOIC	DW	20	2000	Green (RoHS & no Sb/Br)	CU NIPDAU	Level-1-260C-UNLIM
CD74HCT299ME4	ACTIVE	SOIC	DW	20	25	Green (RoHS & no Sb/Br)	CU NIPDAU	Level-1-260C-UNLIM
CD74HCT299MG4	ACTIVE	SOIC	DW	20	25	Green (RoHS & no Sb/Br)	CU NIPDAU	Level-1-260C-UNLIM

⁽¹⁾ The marketing status values are defined as follows:

ACTIVE: Product device recommended for new designs.

LIFEBUY: TI has announced that the device will be discontinued, and a lifetime-buy period is in effect.

NRND: Not recommended for new designs. Device is in production to support existing customers, but TI does not recommend using this part in a new design.

PREVIEW: Device has been announced but is not in production. Samples may or may not be available.

OBsolete: TI has discontinued the production of the device.

⁽²⁾ Eco Plan - The planned eco-friendly classification: Pb-Free (RoHS), Pb-Free (RoHS Exempt), or Green (RoHS & no Sb/Br) - please check <http://www.ti.com/productcontent> for the latest availability information and additional product content details.

TBD: The Pb-Free/Green conversion plan has not been defined.

Pb-Free (RoHS): TI's terms "Lead-Free" or "Pb-Free" mean semiconductor products that are compatible with the current RoHS requirements for all 6 substances, including the requirement that lead not exceed 0.1% by weight in homogeneous materials. Where designed to be soldered

at high temperatures, TI Pb-Free products are suitable for use in specified lead-free processes.

Pb-Free (RoHS Exempt): This component has a RoHS exemption for either 1) lead-based flip-chip solder bumps used between the die and package, or 2) lead-based die adhesive used between the die and leadframe. The component is otherwise considered Pb-Free (RoHS compatible) as defined above.

Green (RoHS & no Sb/Br): TI defines "Green" to mean Pb-Free (RoHS compatible), and free of Bromine (Br) and Antimony (Sb) based flame retardants (Br or Sb do not exceed 0.1% by weight in homogeneous material)

(3) MSL, Peak Temp. -- The Moisture Sensitivity Level rating according to the JEDEC industry standard classifications, and peak solder temperature.

Important Information and Disclaimer: The information provided on this page represents TI's knowledge and belief as of the date that it is provided. TI bases its knowledge and belief on information provided by third parties, and makes no representation or warranty as to the accuracy of such information. Efforts are underway to better integrate information from third parties. TI has taken and continues to take reasonable steps to provide representative and accurate information but may not have conducted destructive testing or chemical analysis on incoming materials and chemicals. TI and TI suppliers consider certain information to be proprietary, and thus CAS numbers and other limited information may not be available for release.

In no event shall TI's liability arising out of such information exceed the total purchase price of the TI part(s) at issue in this document sold by TI to Customer on an annual basis.

TAPE AND REEL INFORMATION

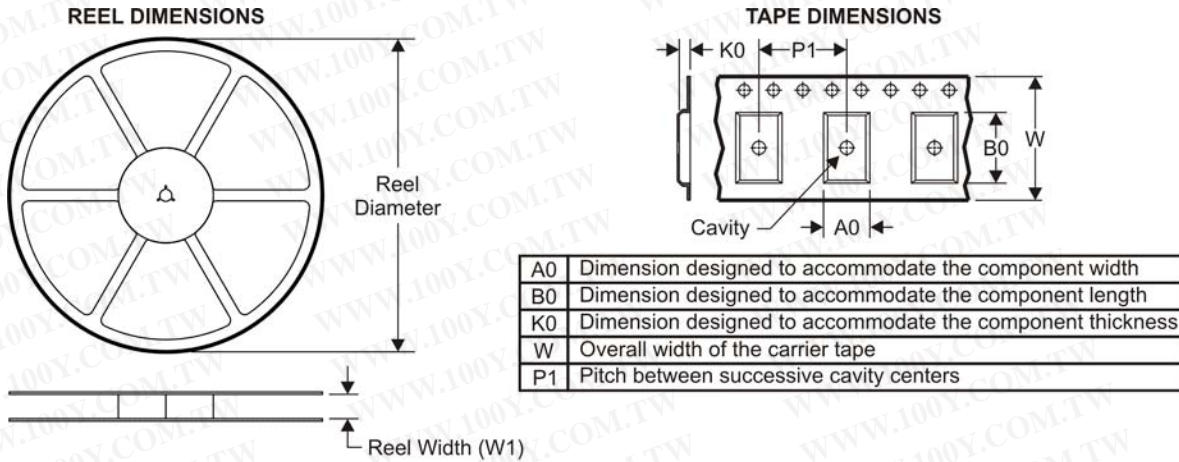

QUADRANT ASSIGNMENTS FOR PIN 1 ORIENTATION IN TAPE

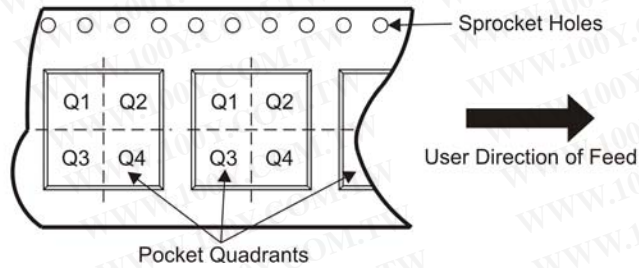

*All dimensions are nominal

Device	Package Type	Package Drawing	Pins	SPQ	Reel Diameter (mm)	Reel Width W1 (mm)	A0 (mm)	B0 (mm)	K0 (mm)	P1 (mm)	W (mm)	Pin1 Quadrant
CD74HC299M96	SOIC	DW	20	2000	330.0	24.4	10.8	13.0	2.7	12.0	24.0	Q1
CD74HCT299M96	SOIC	DW	20	2000	330.0	24.4	10.8	13.0	2.7	12.0	24.0	Q1

TAPE AND REEL BOX DIMENSIONS

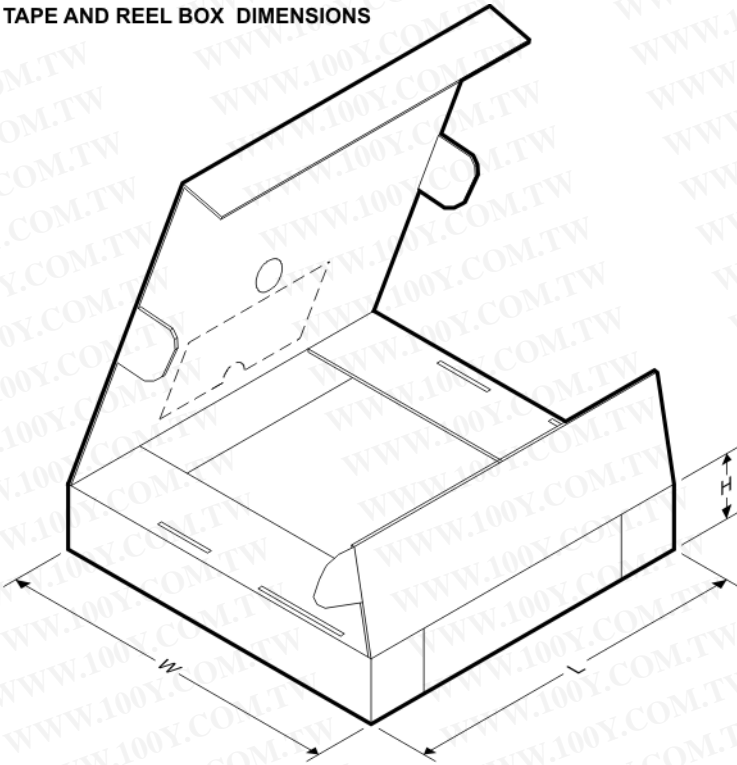

*All dimensions are nominal

Device	Package Type	Package Drawing	Pins	SPQ	Length (mm)	Width (mm)	Height (mm)
CD74HC299M96	SOIC	DW	20	2000	346.0	346.0	41.0
CD74HCT299M96	SOIC	DW	20	2000	346.0	346.0	41.0

J (R-GDIP-T**) 14 LEADS SHOWN

CERAMIC DUAL IN-LINE PACKAGE

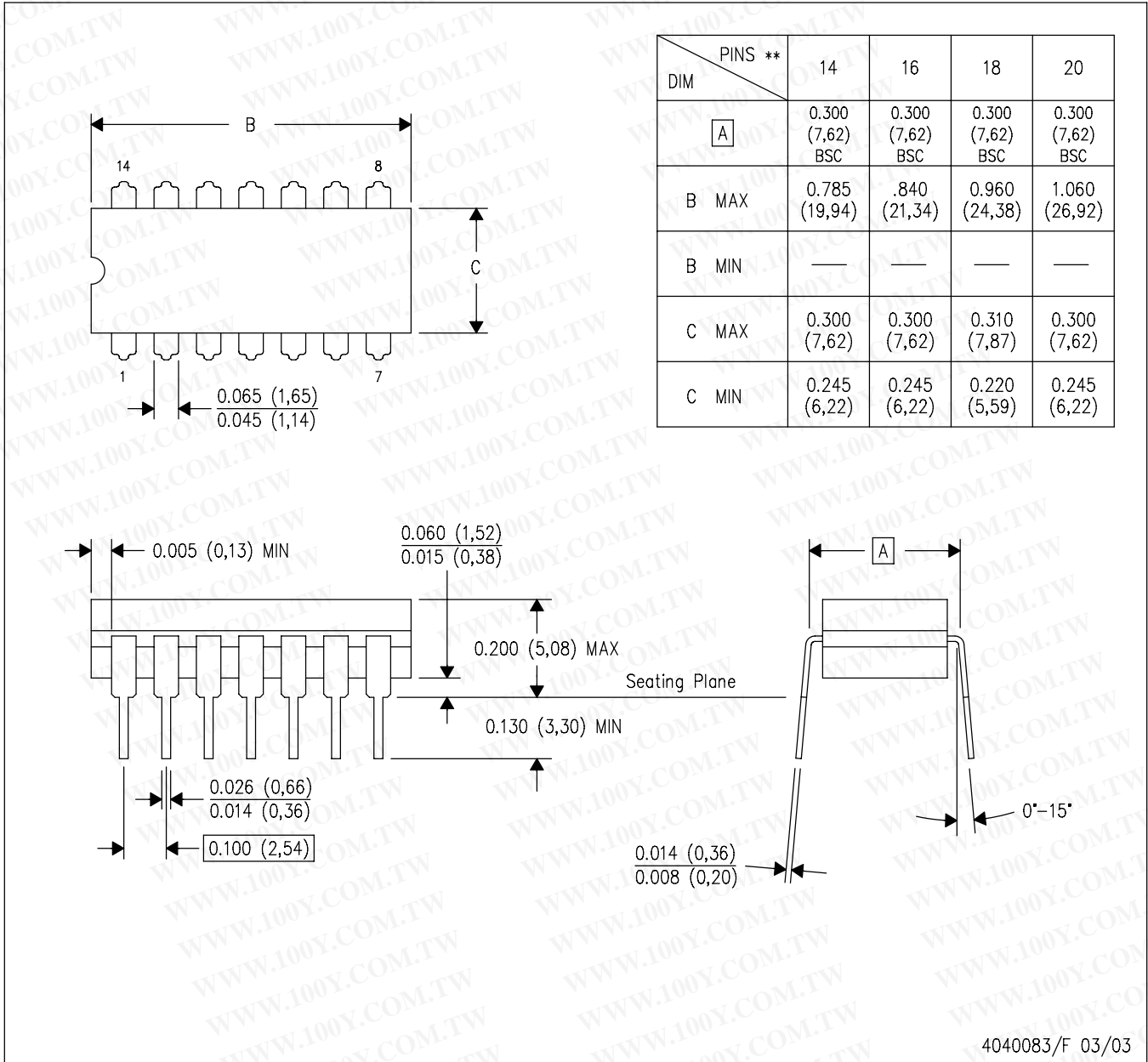

- NOTES:
- A. All linear dimensions are in inches (millimeters).
 - B. This drawing is subject to change without notice.
 - C. This package is hermetically sealed with a ceramic lid using glass frit.
 - D. Index point is provided on cap for terminal identification only on press ceramic glass frit seal only.
 - E. Falls within MIL STD 1835 GDIP1-T14, GDIP1-T16, GDIP1-T18 and GDIP1-T20.

DW (R-PDSO-G20)

PLASTIC SMALL-OUTLINE PACKAGE

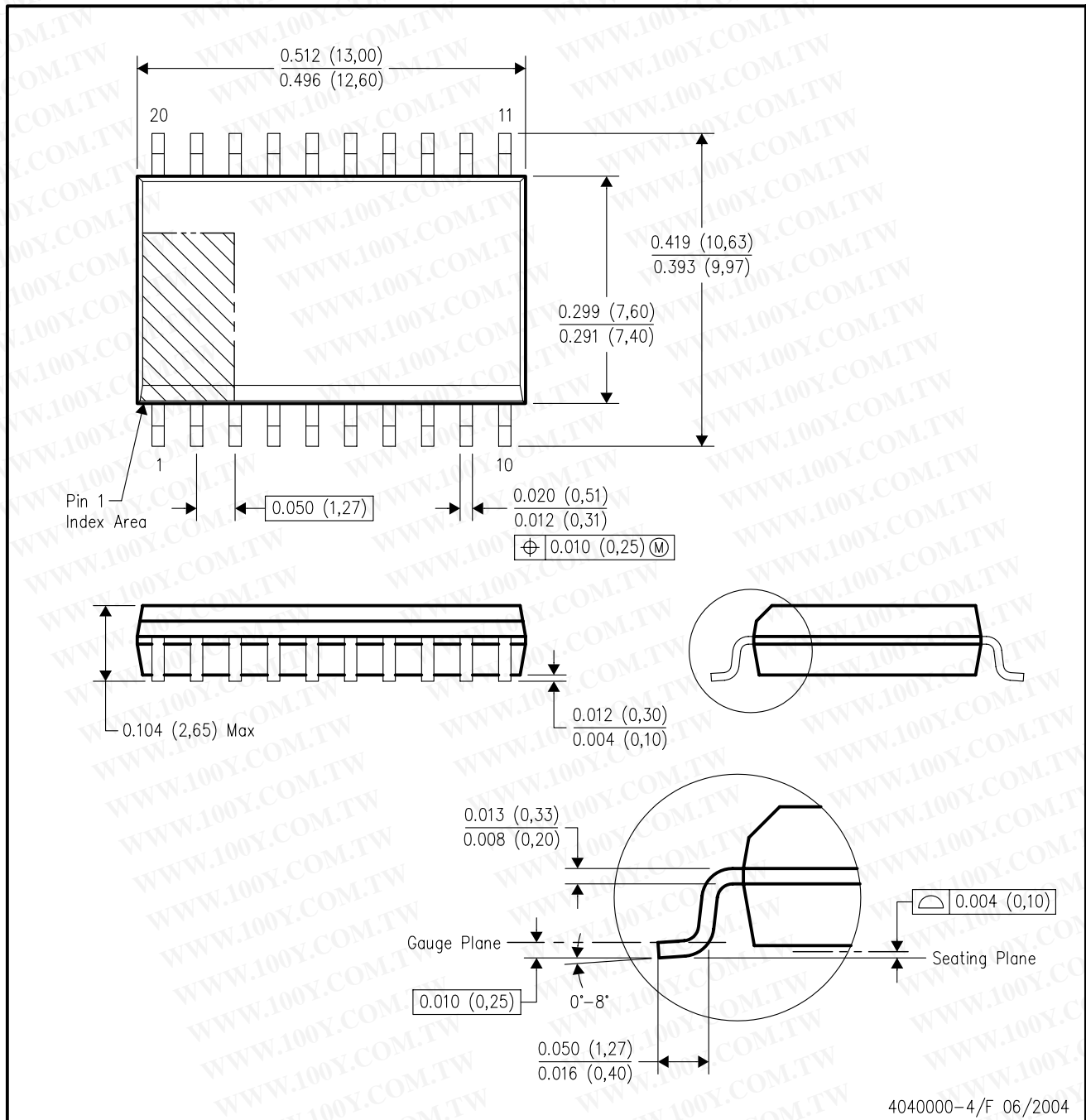

- NOTES:
- A. All linear dimensions are in inches (millimeters).
 - B. This drawing is subject to change without notice.
 - C. Body dimensions do not include mold flash or protrusion not to exceed 0.006 (0,15).
 - D. Falls within JEDEC MS-013 variation AC.

N (R-PDIP-T**)

PLASTIC DUAL-IN-LINE PACKAGE

16 PINS SHOWN

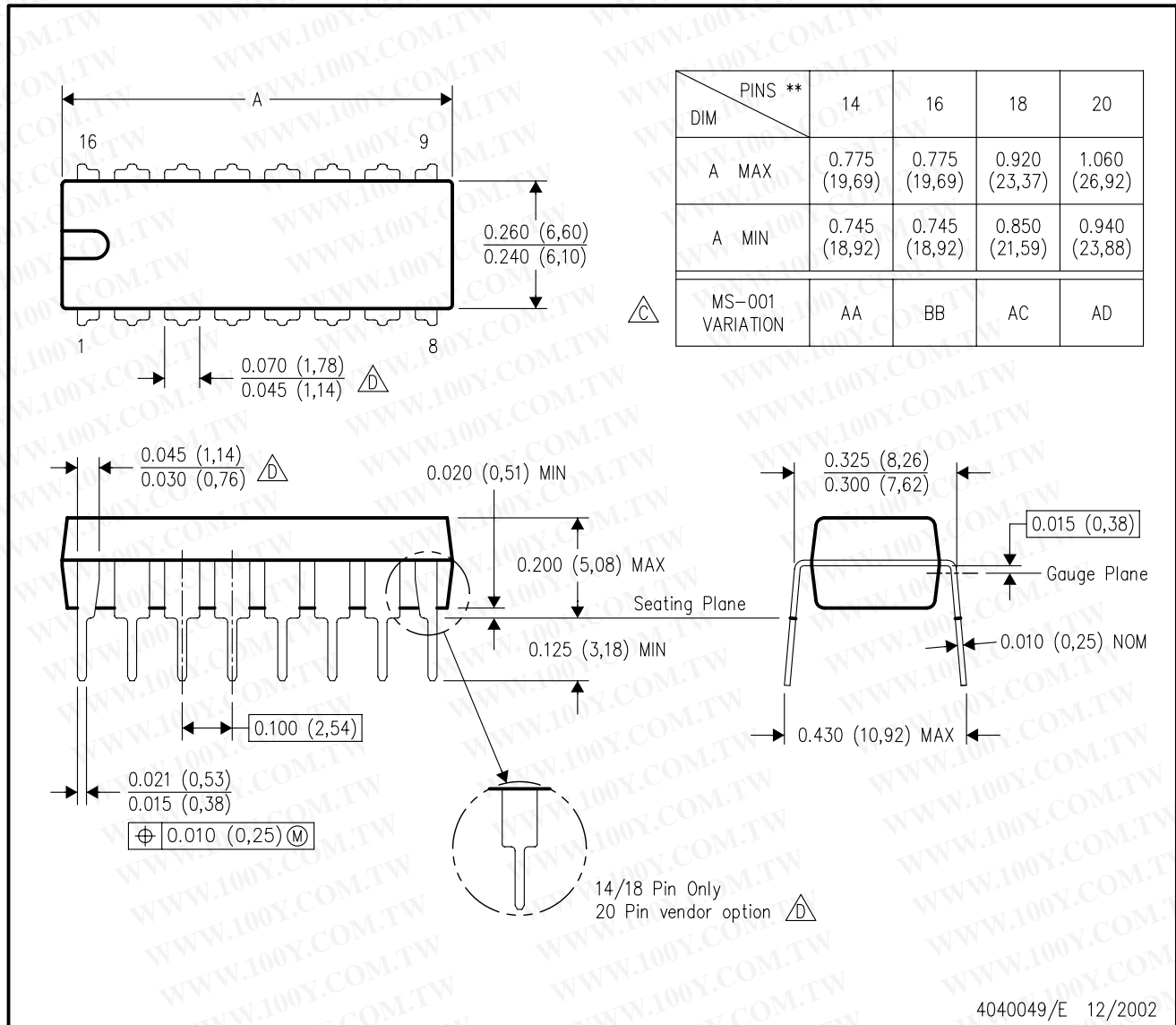

- NOTES:
- A. All linear dimensions are in inches (millimeters).
 - B. This drawing is subject to change without notice.
 - $\triangle C$ Falls within JEDEC MS-001, except 18 and 20 pin minimum body length (Dim A).
 - $\triangle D$ The 20 pin end lead shoulder width is a vendor option, either half or full width.

勝特力材料 886-3-5753170
勝特力电子(上海) 86-21-34970699
勝特力电子(深圳) 86-755-83298787
[Http://www.100y.com.tw](http://www.100y.com.tw)

IMPORTANT NOTICE

Texas Instruments Incorporated and its subsidiaries (TI) reserve the right to make corrections, modifications, enhancements, improvements, and other changes to its products and services at any time and to discontinue any product or service without notice. Customers should obtain the latest relevant information before placing orders and should verify that such information is current and complete. All products are sold subject to TI's terms and conditions of sale supplied at the time of order acknowledgment.

TI warrants performance of its hardware products to the specifications applicable at the time of sale in accordance with TI's standard warranty. Testing and other quality control techniques are used to the extent TI deems necessary to support this warranty. Except where mandated by government requirements, testing of all parameters of each product is not necessarily performed.

TI assumes no liability for applications assistance or customer product design. Customers are responsible for their products and applications using TI components. To minimize the risks associated with customer products and applications, customers should provide adequate design and operating safeguards.

TI does not warrant or represent that any license, either express or implied, is granted under any TI patent right, copyright, mask work right, or other TI intellectual property right relating to any combination, machine, or process in which TI products or services are used. Information published by TI regarding third-party products or services does not constitute a license from TI to use such products or services or a warranty or endorsement thereof. Use of such information may require a license from a third party under the patents or other intellectual property of the third party, or a license from TI under the patents or other intellectual property of TI.

Reproduction of TI information in TI data books or data sheets is permissible only if reproduction is without alteration and is accompanied by all associated warranties, conditions, limitations, and notices. Reproduction of this information with alteration is an unfair and deceptive business practice. TI is not responsible or liable for such altered documentation. Information of third parties may be subject to additional restrictions.

Resale of TI products or services with statements different from or beyond the parameters stated by TI for that product or service voids all express and any implied warranties for the associated TI product or service and is an unfair and deceptive business practice. TI is not responsible or liable for any such statements.

TI products are not authorized for use in safety-critical applications (such as life support) where a failure of the TI product would reasonably be expected to cause severe personal injury or death, unless officers of the parties have executed an agreement specifically governing such use. Buyers represent that they have all necessary expertise in the safety and regulatory ramifications of their applications, and acknowledge and agree that they are solely responsible for all legal, regulatory and safety-related requirements concerning their products and any use of TI products in such safety-critical applications, notwithstanding any applications-related information or support that may be provided by TI. Further, Buyers must fully indemnify TI and its representatives against any damages arising out of the use of TI products in such safety-critical applications.

TI products are neither designed nor intended for use in military/aerospace applications or environments unless the TI products are specifically designated by TI as military-grade or "enhanced plastic." Only products designated by TI as military-grade meet military specifications. Buyers acknowledge and agree that any such use of TI products which TI has not designated as military-grade is solely at the Buyer's risk, and that they are solely responsible for compliance with all legal and regulatory requirements in connection with such use.

TI products are neither designed nor intended for use in automotive applications or environments unless the specific TI products are designated by TI as compliant with ISO/TS 16949 requirements. Buyers acknowledge and agree that, if they use any non-designated products in automotive applications, TI will not be responsible for any failure to meet such requirements.

Following are URLs where you can obtain information on other Texas Instruments products and application solutions:

Products

Amplifiers	amplifier.ti.com
Data Converters	dataconverter.ti.com
DLP® Products	www.dlp.com
DSP	dsp.ti.com
Clocks and Timers	www.ti.com/clocks
Interface	interface.ti.com
Logic	logic.ti.com
Power Mgmt	power.ti.com
Microcontrollers	microcontroller.ti.com
RFID	www.ti-rfid.com
RF/IF and ZigBee® Solutions	www.ti.com/lprf

Applications

Audio	www.ti.com/audio
Automotive	www.ti.com/automotive
Broadband	www.ti.com/broadband
Digital Control	www.ti.com/digitalcontrol
Medical	www.ti.com/medical
Military	www.ti.com/military
Optical Networking	www.ti.com/opticalnetwork
Security	www.ti.com/security
Telephony	www.ti.com/telephony
Video & Imaging	www.ti.com/video
Wireless	www.ti.com/wireless

Mailing Address: Texas Instruments, Post Office Box 655303, Dallas, Texas 75265
Copyright © 2009, Texas Instruments Incorporated