

14-stage binary counter/oscillator

Datasheet - production data

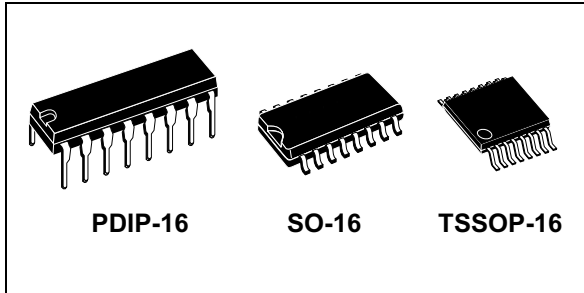

Applications

- Automotive
- Industrial
- Computer
- Consumer

Description

The M74HC4060 device is a high speed CMOS 14-stage binary counter/oscillator fabricated with silicon gate C²MOS technology.

The oscillator configuration allows design of either RC or crystal oscillator circuits. A high level on the CLEAR accomplishes the reset function, i.e. all counter outputs are made low and the oscillator is disabled.

A negative transition on the clock input increments the counter. Ten kinds of divided output are provided; 4 to 10 and 12 to 14 stage inclusive. The maximum division available at Q12 is 1/16384 of the oscillator frequency.

The $\bar{O}1$ input and the CLEAR input are equipped with protection circuits against static discharge and transient excess voltage.

Features

- High speed:
 $f_{max} = 65 \text{ MHz (typ.) at } V_{CC} = 6 \text{ V}$
- Low power dissipation:
 $I_{CC} = 4 \text{ A (max.) at } T_A = 25 \text{ }^\circ\text{C}$
- High noise immunity:
 $V_{NIH} = V_{NIL} = 28\% V_{CC} \text{ (min.)}$
- Symmetrical output impedance:
 $|I_{OH}| = I_{OL} = 4 \text{ mA (min.)}$
- Balanced propagation delays: $T_{PLH} \cong T_{PHL}$
- Wide operating voltage range:
 $V_{CC} \text{ (opr.)} = 2 \text{ V to } 6 \text{ V}$
- Pin and function compatible with 74 series 4060

Table 1. Device summary

Ordering code	Temperature range	Package	Marking
M74HC4060B1R	-55 °C to +125 °C	PDIP-16	M74HC4060B1
M74HC4060RM13TR	-55 °C to +125 °C	SO-16	74HC4060
M74HC4060YRM13TR ⁽¹⁾	-40 °C to +125 °C	SO-16 (automotive version)	74HC4060Y
M74HC4060TTR	-55 °C to +125 °C	TSSOP-16	HC4060
M74HC4060YTTR ⁽¹⁾	-40 °C to +125 °C	TSSOP-16 (automotive version)	HC4060Y

1. Qualification and characterization according to AEC Q100 and Q003 or equivalent, advanced screening according to AEC Q001 and Q002 or equivalent.

Contents

1	Pin description	3
2	Functional description	4
3	Maximum ratings	5
4	Electrical characteristics	6
5	Waveforms	9
6	Package information	12
7	Revision history	15

1 Pin description

Figure 1. Pin connection and IEC logic symbols

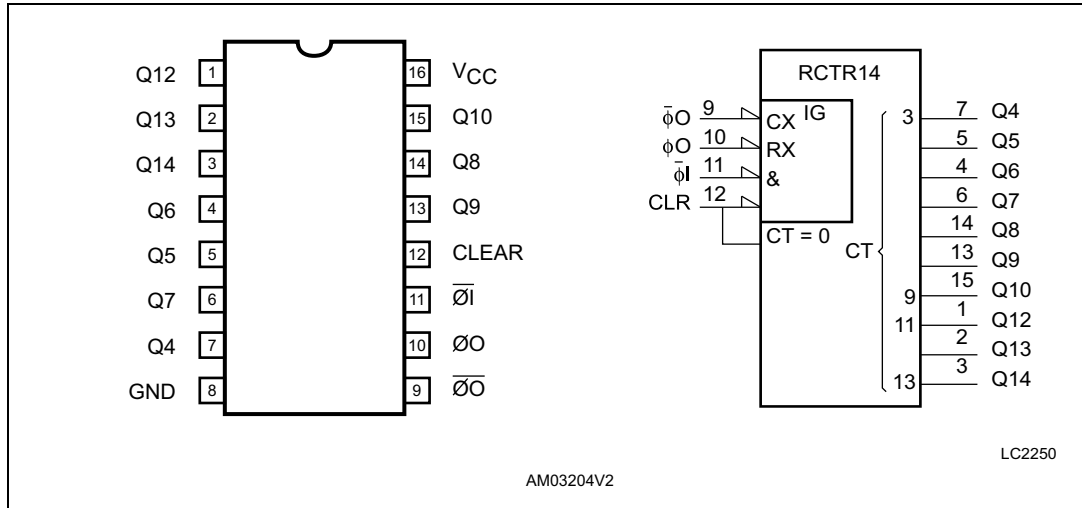

Figure 2. Input and output equivalent circuit

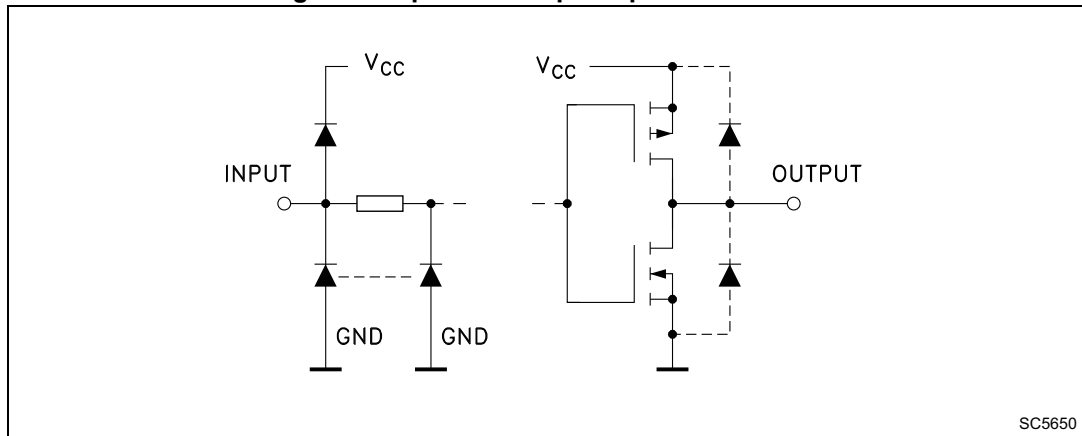

Table 2. Pin description

Pin no	Symbol	Name and function
1, 2, 3	Q12 to Q14	Counter outputs
7, 5, 4, 6, 14, 13, 15	Q4 to Q10	Counter outputs
9	$\overline{\text{ØO}}$	External capacitor connection
10	ØO	External resistor connection
11	$\overline{\text{ØI}}$	Clock input / oscillator pin
12	CLEAR	Master reset
8	GND	Ground (0 V)
16	V_{CC}	Positive supply voltage

3 Maximum ratings

Table 4. Absolute maximum ratings⁽¹⁾

Symbol	Parameter	Value	Unit
V_{CC}	Supply voltage	-0.5 to +7	V
V_I	DC Input voltage	-0.5 to $V_{CC} + 0.5$	V
V_O	DC output voltage	-0.5 to $V_{CC} + 0.5$	V
I_{IK}	DC input diode current	20	mA
I_{OK}	DC output diode current	20	mA
I_O	DC output current	25	mA
I_{CC} or I_{GND}	DC VCC or ground current	50	mA
P_D	Power dissipation	500 ⁽²⁾	mW
T_{stg}	Storage temperature	-65 to +150	°C
T_L	Lead temperature (10 sec.)	300	°C

1. Absolute maximum ratings are those values beyond which damage to the device may occur. Functional operation under these conditions is not implied.
2. 500 mW at 65 °C; derate to 300 mW by 10 mW/ °C from 65 °C to 85 °C.

Table 5. Recommended operating conditions

Symbol	Parameter		Value	Unit
V_C	Supply voltage		2 to 6	V
V_I	Input voltage		0 to V_{CC}	V
V_O	Output voltage		0 to V_{CC}	V
T_{op}	Operating temperature		-55 to 125	°C
t_r, t_f	Input rise and fall time	$V_{CC} = 2.0\text{ V}$	0 to 1000	ns
		$V_{CC} = 4.5\text{ V}$	0 to 500	ns
		$V_{CC} = 6.0\text{ V}$	0 to 400	ns

4 Electrical characteristics

Table 6. DC specifications

Symbol	Parameter	Test condition		Value						Unit	
		V _{CC} (V)		T _A = 25°C			-40 to 85 °C		-55 to 125 °C		
				Min.	Typ.	Max.	Min.	Max.	Min.		Max.
V _{IH}	High level input voltage	2.0		1.5			1.5		1.5		V
		4.5		3.15			3.15		3.15		
		6.0		4.2			4.2		4.2		
V _{IL}	Low level input voltage	2.0				0.5		0.5		0.5	V
		4.5				1.35		1.35		1.35	
		6.0				1.8		1.8		1.8	
V _{OH}	High level output voltage (Q output)	2.0	I _O = -20 A	1.9	2.0		1.9		1.9		V
		4.5	I _O = -20 A	4.4	4.5		4.4		4.4		
		6.0	I _O = -20 A	5.9	6.0		5.9		5.9		
		4.5	I _O = -4.0 mA	4.18	4.31		4.13		4.10		
		6.0	I _O = -5.2 mA	5.68	5.8		5.63		5.60		
V _{OL}	Low level output voltage (Q output)	2.0	I _O = 20 A		0.0	0.1		0.1		0.1	V
		4.5	I _O = 20 A		0.0	0.1		0.1		0.1	
		6.0	I _O = 20 A		0.0	0.1		0.1		0.1	
		4.5	I _O = 4.0 mA		0.17	0.26		0.33		0.40	
		6.0	I _O = 5.2 mA		0.18	0.26		0.33		0.40	
V _{OH}	High level output voltage (\overline{Q} O, \overline{Q} \overline{O} output)	2.0	I _O = -20 A	1.8	2.0		1.8		1.8	2.0	V
		4.5	I _O = -20 A	4.4	4.5		4.0		4.0		
		6.0	I _O = -20 A	5.5	5.9		5.5		5.5		
V _{OL}	Low level output voltage (\overline{Q} O, \overline{Q} \overline{O} output)	2.0	I _O = -20 A		0.0	0.2		0.2		0.2	V
		4.5	I _O = -20 A		0.0	0.5		0.5		0.5	
		6.0	I _O = -20 A		0.1	0.5		0.5		0.5	
I _I	Input leakage current	6.0	V _I = V _{CC} or GND			0.1		±1		±1	μA
I _{CC}	Quiescent supply current	6.0	V _I = V _{CC} or GND			4		40		80	μA

Table 7. AC electrical characteristics ($C_L = 50$ pF, input $t_r = t_f = 6$ ns)

Symbol	Parameter	Test condition	Value						Unit		
			V _{CC} (V)	T _A = 25 °C			-40 to 85 °C			-55 to 125 °C	
				Min.	Typ.	Max.	Min.	Max.		Min.	Max.
t _{TLH} t _{THL}	Output transition time	2.0		30	75		95		110	ns	
		4.5		8	15		19		22		
		6.0		7	13		16		19		
t _{PLH} t _{PHL}	Propagation delay time ($\overline{Q1} - \overline{Q4}$)	2.0		170	300		375		450	ns	
		4.5		41	60		75		90		
		6.0		30	51		64		76		
t _{PD}	Propagation delay time difference (Q _n - Q _{n+1})	2.0		32	75		95		110	ns	
		4.5		7	15		19		22		
		6.0		5	13		16		19		
t _{PHL}	Propagation delay time (CLEAR - Q _n)	2.0		85	195		245		295	ns	
		4.5		23	39		49		59		
		6.0		17	33		42		50		
f _{MAX}	Maximum clock frequency	2.0	6	12		5		4		MHz	
		4.5	30	50		24		20			
		6.0	35	65		28		24			
t _{W(H)} , t _{W(L)}	Minimum pulse width ($\overline{Q1}$)	2.0		30	75		95		110	ns	
		4.5		8	15		19		22		
		6.0		7	13		16		19		
t _{W(H)}	Minimum pulse width (CLEAR)	2.0		30	75		95		110	ns	
		4.5		8	15		19		22		
		6.0		7	13		16		19		
t _{REM}	Minimum removal time	2.0		40	100		125		150	ns	
		4.5		10	20		25		30		
		6.0		9	17		21		26		

Table 8. Capacitive characteristics

Symbol	Parameter	Test condition	Value						Unit	
		V _{CC} (V)	T _A = 25 °C			-40 to 85 °C		-55 to 125 °C		
			Min.	Typ.	Max.	Min.	Max.	Min.		Max.
C _{IN}	Input capacitance	5.0	5	10		10		10		pF
C _{PD}	Power dissipation capacitance ⁽¹⁾	5.0		27						pF

1. C_{PD} is defined as the value of the IC's internal equivalent capacitance which is calculated from the operating current consumption without load. (Refer to [Figure 4: Test circuit](#)). Average operating current can be obtained by the following equation. $I_{CC(opr.)} = C_{PD} \times V_{CC} \times f_{IN} + I_{CC}$.

Figure 4. Test circuit

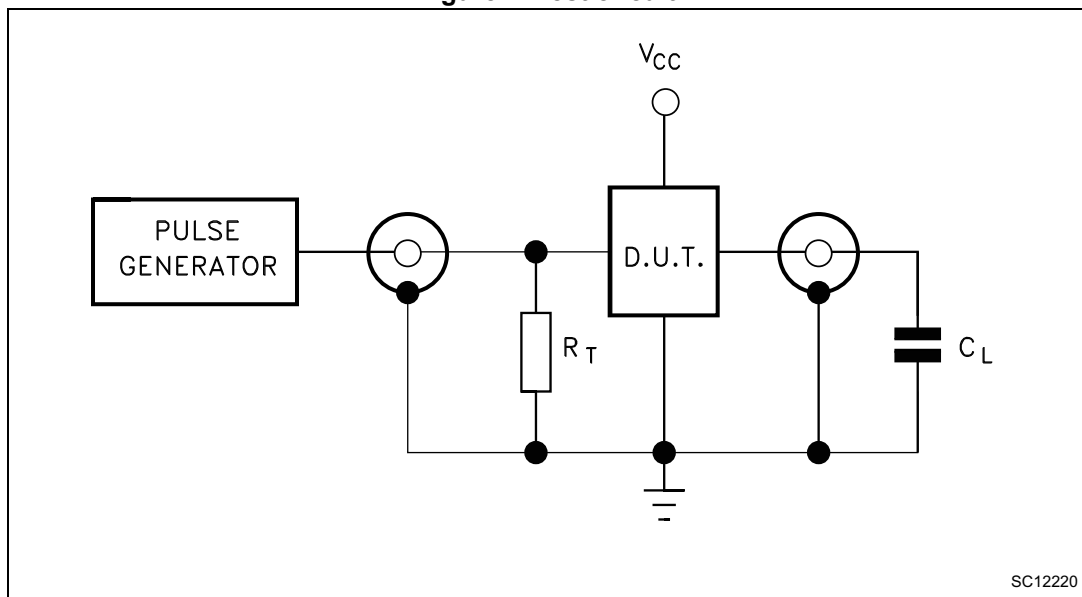

1. C_L = 50 pF or equivalent (includes jig and probe capacitance)
 R_T = Z_{OUT} of pulse generator (typically 50 Ω).

5 Waveforms

**Figure 5. Waveform 1: propagation delay times, minimum pulse width ($\overline{\text{ØI}}$)
(f = 1 MHz; 50% duty cycle)**

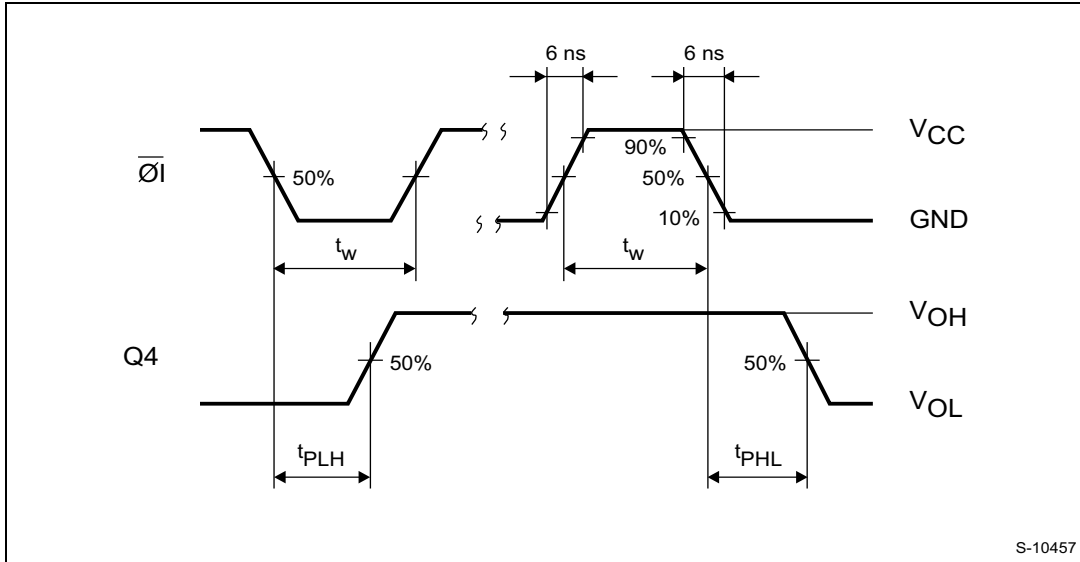

S-10457

**Figure 6. Waveform 2: propagation delay times, minimum pulse width (CLEAR)
(f = 1 MHz; 50% duty cycle)**

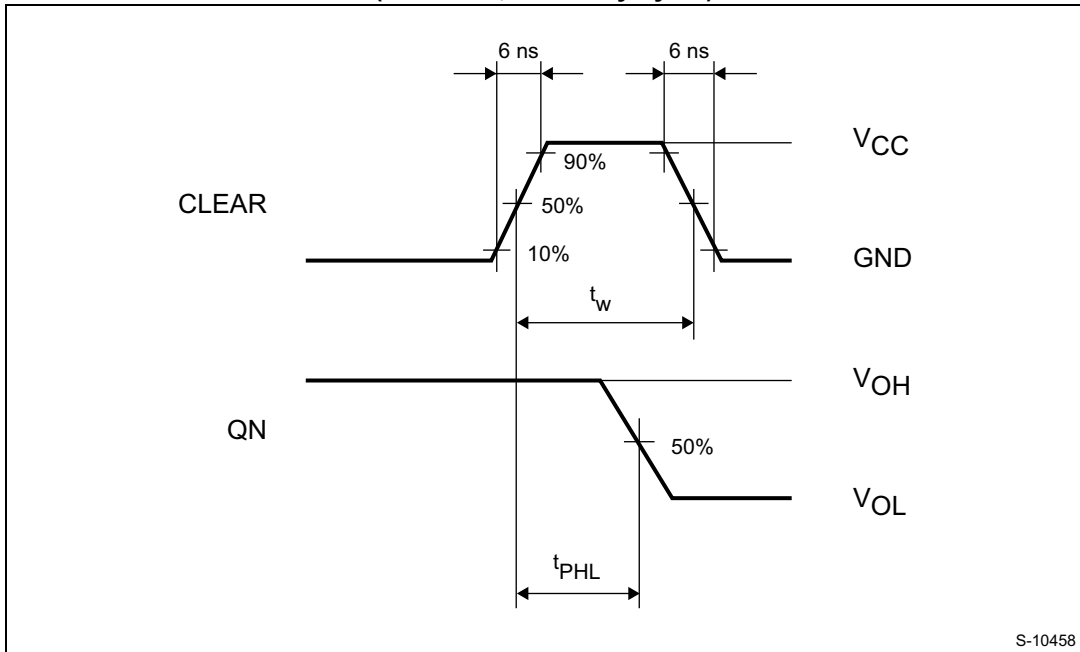

S-10458

Figure 7. Waveform 3: propagation delay times (f = 1 MHz; 50% duty cycle)

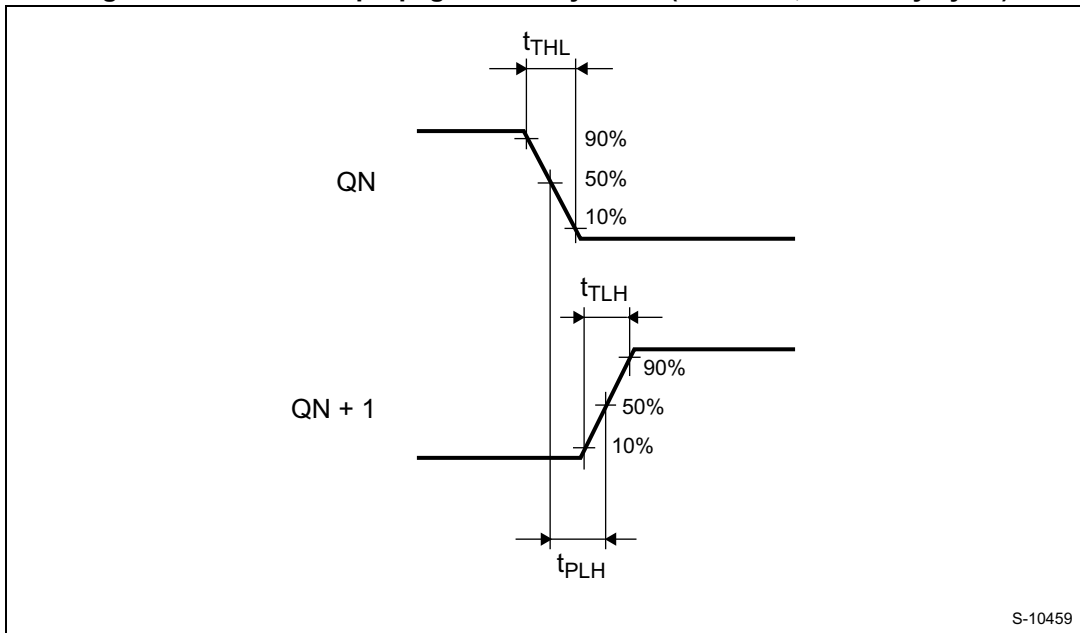

Figure 8. Waveform 4: propagation delay times (f = 1 MHz; 50% duty cycle)

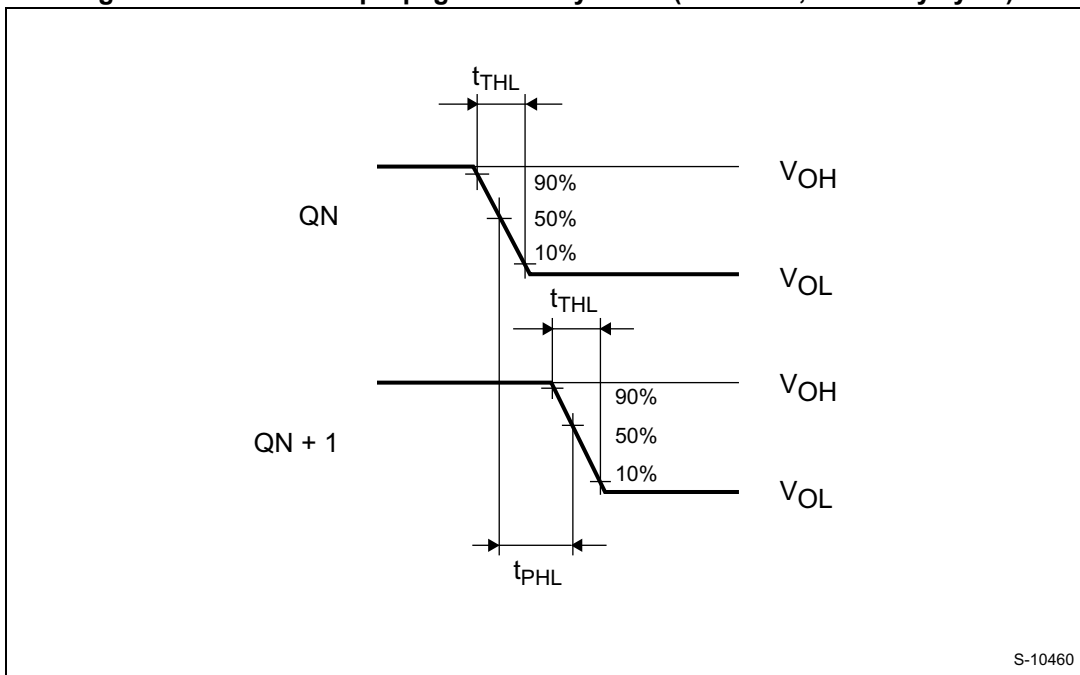
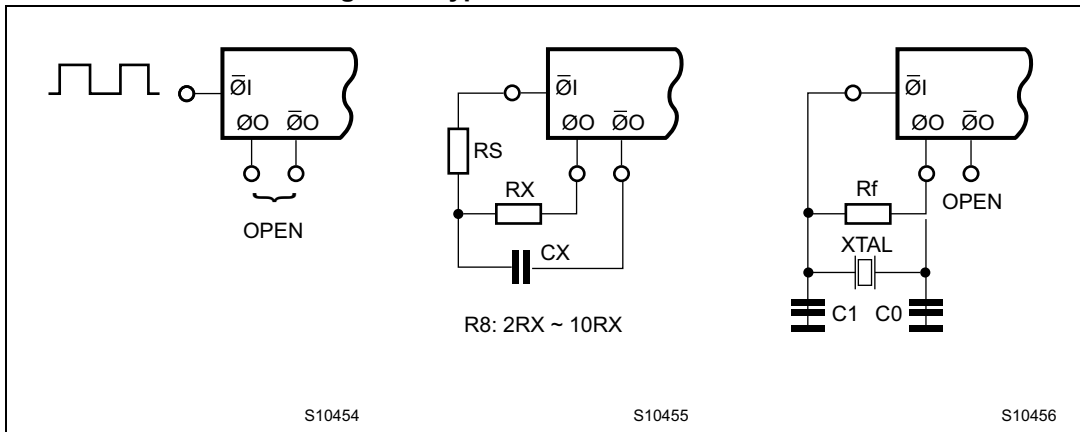

Figure 9. Typical clock drive circuits



勝特力電材超市-龍山店 886-3-5773766
 勝特力電材超市-光復店 886-3-5729570
 勝特力電子(上海) 86-21-34970699
 勝特力電子(深圳) 86-755-83298787
<http://www.100y.com.tw>

6 Package information

In order to meet environmental requirements, ST offers these devices in different grades of ECOPACK® packages, depending on their level of environmental compliance. ECOPACK specifications, grade definitions and product status are available at: www.st.com. ECOPACK is an ST trademark.

Figure 10. Plastic DIP-16 package outline

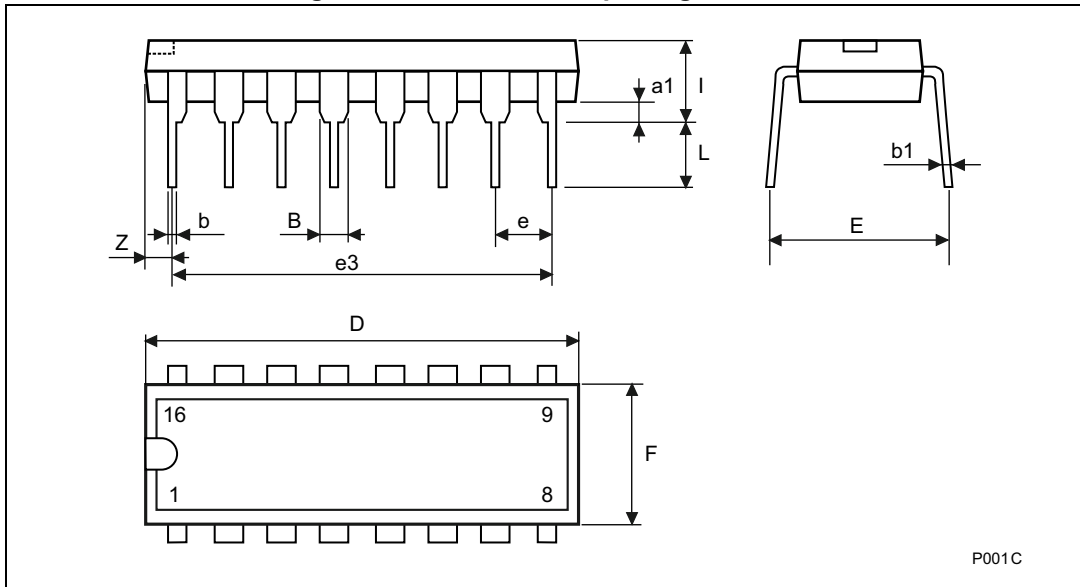
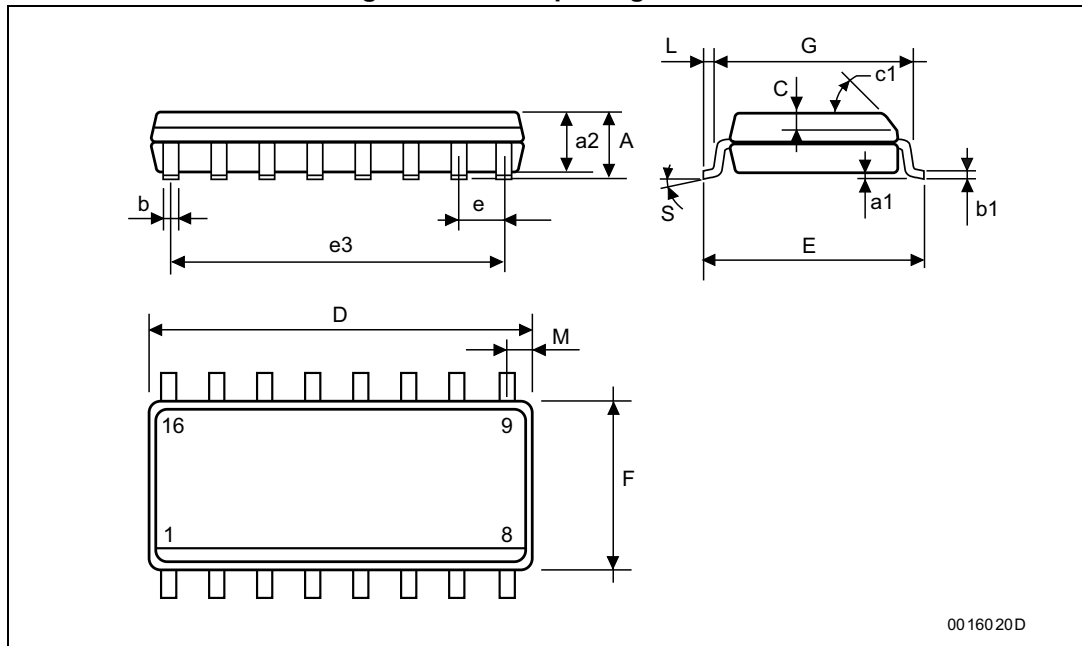

Table 9. Plastic DIP-16 (0.25) package mechanical data

Symbol	Dimensions					
	mm			inch		
	Min.	Typ.	Max.	Min.	Typ.	Max.
a1	0.51			0.020		
B	0.77		1.65	0.030		0.065
b		0.5			0.020	
b1		0.25			0.010	
D			20			0.787
E		8.5			0.335	
e		2.54			0.100	
e3		17.78			0.700	
F			7.1			0.280
I			5.1			0.201
L		3.3			0.130	
Z			1.27			0.050

Figure 11. SO-16 package outline



00 16020D

Table 10. SO-16 package mechanical data

Symbol	Dimensions					
	mm			inch		
	Min.	Typ.	Max.	Min.	Typ.	Max.
A			1.75			0.068
a1	0.1		0.2	0.003		0.007
a2			1.65			0.064
b	0.35		0.46	0.013		0.018
b1	0.19		0.25	0.007		0.010
C		0.5			0.019	
c1	45° (typ.)					
D	9.8		10	0.385		0.393
E	5.8		6.2	0.228		0.244
e		1.27			0.050	
e3		8.89			0.350	
F	3.8		4.0	0.149		0.157
G	4.6		5.3	0.181		0.208
L	0.5		1.27	0.019		0.050
M			0.62			0.024
S	8° (max.)					

Figure 12. TSSOP-16 package outline

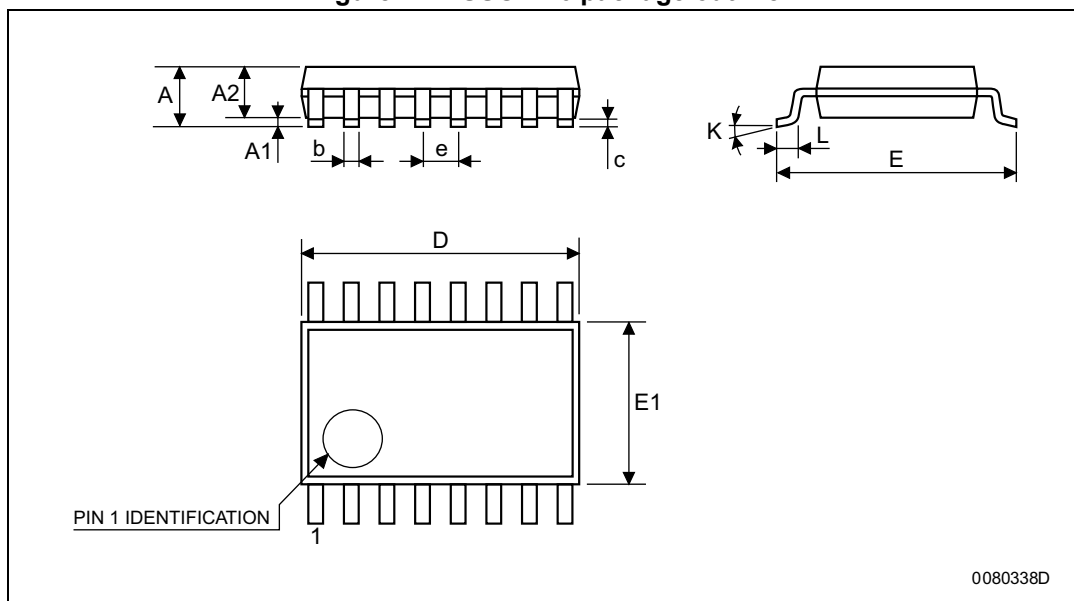

Table 11. TSSOP-16 mechanical data

Symbol	Dimensions					
	mm			inch		
	Min.	Typ.	Max.	Min.	Typ.	Max.
A			1.2			0.047
A1	0.05		0.15	0.002	0.004	0.006
A2	0.8	1	1.05	0.031	0.039	0.041
b	0.19		0.30	0.007		0.012
c	0.09		0.20	0.004		0.0089
D	4.9	5	5.1	0.193	0.197	0.201
E	6.2	6.4	6.6	0.244	0.252	0.260
E1	4.3	4.4	4.48	0.169	0.173	0.176
e		0.65 BSC			0.0256 BSC	
K	0°		8°	0°		8°
L	0.45	0.60	0.75	0.018	0.024	0.030

7 Revision history

Table 12. Document revision history

Date	Revision	Changes
1-Feb-2008	1	Initial release.
15-May-2013	2	<p>Added Applications on page 1.</p> <p>Corrected Description (replaced “The maximum division available at Q12 is 1/16384 f oscillator.” by “The maximum division available at Q12 is 1/16384 of the oscillator frequency.”).</p> <p>Updated Table 1 (added order codes, temperature range, updated package, added marking).</p> <p>Moved Figure 1 to page 3.</p> <p>Redrawn Figure 1, Figure 3, Figure 5 to Figure 9.</p> <p>Added Contents.</p> <p>Added titles to Section 1: Pin description to Section 7: Revision history.</p> <p>Added numbers to Table 1 to Table 12 and Figure 1 to Figure 12.</p> <p>Updated Section 6: Package information (added ECOPACK text, reversed order of Figure 10 to Figure 12 and Table 10 to Table 11).</p> <p>Minor corrections throughout document.</p>