

HD74HC244

Octal Buffers/Line Drivers/Line Receivers (with noninverted 3-state outputs)

REJ03D0597-0200
(Previous ADE-205-474)
Rev.2.00
Jan 31, 2006

Description

The HD74HC244 is a non-inverting buffer and has two active low enables ($\overline{1G}$ and $\overline{2G}$). Each enable independently controls 4 buffers.

This device does not have schmitt trigger inputs.

Features

- High Speed Operation: $t_{pd} = 11$ ns typ ($C_L = 50$ pF)
- High Output Current: Fanout of 15 LSTTL Loads
- Wide Operating Voltage: $V_{CC} = 2$ to 6 V
- Low Input Current: 1 μ A max
- Low Quiescent Supply Current: I_{CC} (static) = 4 μ A max ($T_a = 25^\circ\text{C}$)
- Ordering Information

Part Name	Package Type	Package Code (Previous Code)	Package Abbreviation	Taping Abbreviation (Quantity)
HD74HC244P	DILP-20 pin	PRDP0020AC-B (DP-20NEV)	P	—
HD74HC244FPEL	SOP-20 pin (JEITA)	PRSP0020DD-B (FP-20DAV)	FP	EL (2,000 pcs/reel)
HD74HC244RPEL	SOP-20 pin (JEDEC)	PRSP0020DC-A (FP-20DBV)	RP	EL (1,000 pcs/reel)
HD74HC244TELL	TSSOP-20 pin	PTSP0020JB-A (TTP-20DAV)	T	ELL(2,000 pcs/reel)

Note: Please consult the sales office for the above package availability.

Function Table

Inputs		Output
\overline{G}	A	Y
H	X	Z
L	H	H
L	L	L

H : high level

L : low level

X : irrelevant

Z : off (high-impedance) state of a 3-state output

勝特力材料 886-3-5753170
勝特力电子(上海) 86-21-34970699
勝特力电子(深圳) 86-755-83298787
[Http://www.100y.com.tw](http://www.100y.com.tw)

Pin Arrangement

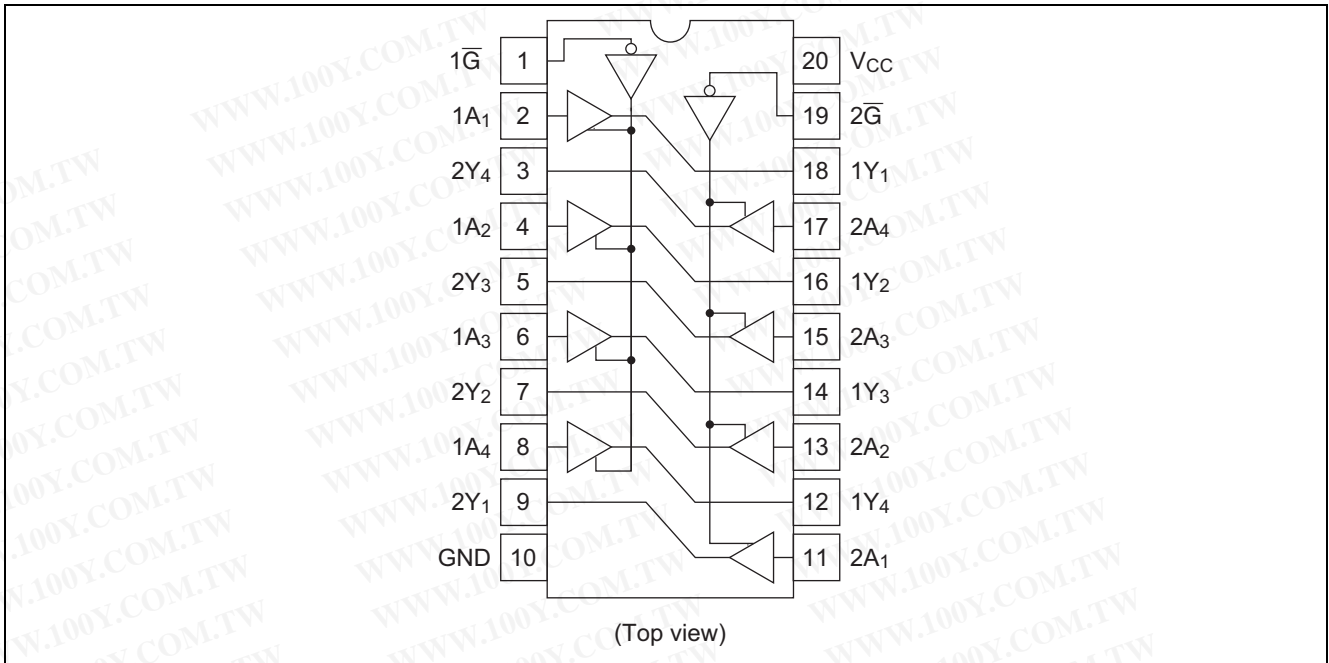

Logic Diagram

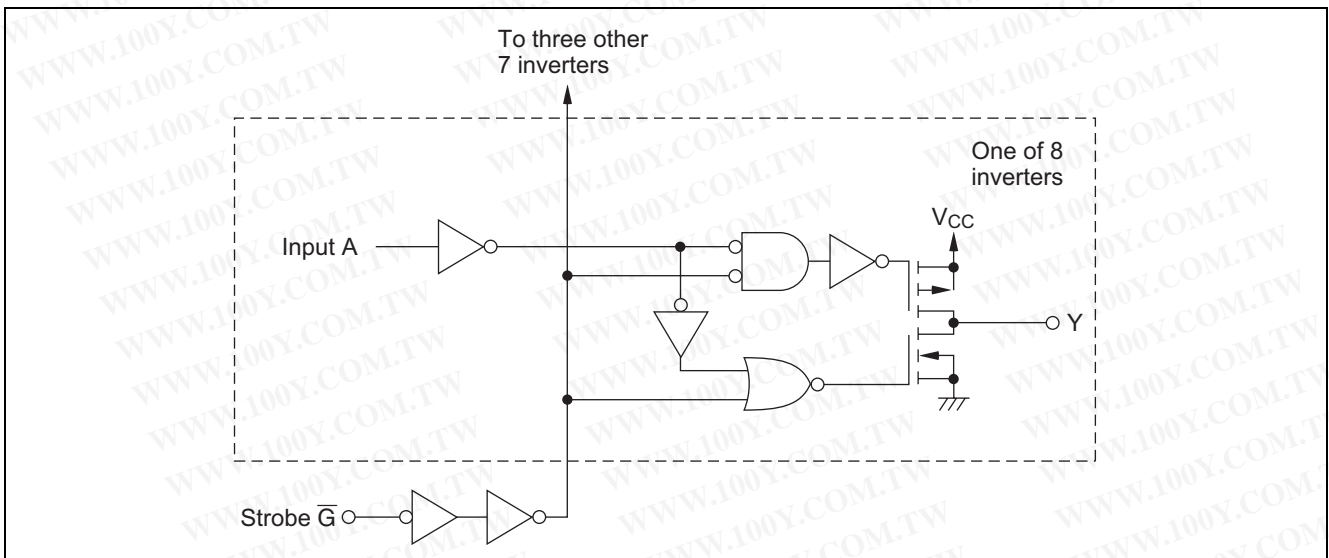

勝特力材料 886-3-5753170
 勝特力电子(上海) 86-21-34970699
 勝特力电子(深圳) 86-755-83298787
[Http://www.100y.com.tw](http://www.100y.com.tw)

Absolute Maximum Ratings

Item	Symbol	Ratings	Unit
Supply voltage range	V_{CC}	-0.5 to 7.0	V
Input / Output voltage	V_{IN}, V_{OUT}	-0.5 to $V_{CC} + 0.5$	V
Input / Output diode current	I_{IK}, I_{OK}	± 20	mA
Output current	I_O	± 35	mA
V_{CC} , GND current	I_{CC} OR I_{GND}	± 75	mA
Power dissipation	P_T	500	mW
Storage temperature	T_{stg}	-65 to +150	$^{\circ}C$

Note: The absolute maximum ratings are values, which must not individually be exceeded, and furthermore, no two of which may be realized at the same time.

Recommended Operating Conditions

Item	Symbol	Ratings	Unit	Conditions
Supply voltage	V_{CC}	2 to 6	V	
Input / Output voltage	V_{IN}, V_{OUT}	0 to V_{CC}	V	
Operating temperature	T_a	-40 to 85	$^{\circ}C$	
Input rise / fall time ¹	t_r, t_f	0 to 1000	ns	$V_{CC} = 2.0$ V
		0 to 500		$V_{CC} = 4.5$ V
		0 to 400		$V_{CC} = 6.0$ V

Notes: 1. This item guarantees maximum limit when one input switches.

Waveform: Refer to test circuit of switching characteristics.

Electrical Characteristics

Item	Symbol	V_{CC} (V)	$T_a = 25^{\circ}C$			$T_a = -40$ to $+85^{\circ}C$		Unit	Test Conditions	
			Min	Typ	Max	Min	Max			
Input voltage	V_{IH}	2.0	1.5	—	—	1.5	—	V		
		4.5	3.15	—	—	3.15	—			
		6.0	4.2	—	—	4.2	—			
	V_{IL}	2.0	—	—	0.5	—	0.5	V		
		4.5	—	—	1.35	—	1.35			
		6.0	—	—	1.8	—	1.8			
Output voltage	V_{OH}	2.0	1.9	2.0	—	1.9	—	V	$V_{in} = V_{IH}$ or V_{IL}	$I_{OH} = -20$ μA
		4.5	4.4	4.5	—	4.4	—			$I_{OH} = -6$ mA
		6.0	5.9	6.0	—	5.9	—			$I_{OH} = -7.8$ mA
		4.5	4.18	—	—	4.13	—			
		6.0	5.68	—	—	5.63	—			
		4.5	—	—	0.26	—	0.33			
	V_{OL}	2.0	—	0.0	0.1	—	0.1	V	$V_{in} = V_{IH}$ or V_{IL}	$I_{OL} = 20$ μA
		4.5	—	0.0	0.1	—	0.1			
		6.0	—	0.0	0.1	—	0.1			
		4.5	—	—	0.26	—	0.33			$I_{OL} = 6$ mA
6.0	—	—	0.26	—	0.33	$I_{OL} = 7.8$ mA				
Off-state output current	I_{OZ}	6.0	—	—	± 0.5	—	± 5.0	μA	$V_{in} = V_{IH}$ or V_{IL} , $V_{out} = V_{CC}$ or GND	
Input current	I_{in}	6.0	—	—	± 0.1	—	± 1.0	μA	$V_{in} = V_{CC}$ or GND	
Quiescent supply current	I_{CC}	6.0	—	—	4.0	—	40	μA	$V_{in} = V_{CC}$ or GND, $I_{out} = 0$ μA	

勝特力材料 886-3-5753170
 勝特力电子(上海) 86-21-34970699
 勝特力电子(深圳) 86-755-83298787
[Http://www.100y.com.tw](http://www.100y.com.tw)

Switching Characteristics

($C_L = 50\text{ pF}$, Input $t_r = t_f = 6\text{ ns}$)

Item	Symbol	V_{CC} (V)	$T_a = 25^\circ\text{C}$			$T_a = -40\text{ to }+85^\circ\text{C}$		Unit	Test Conditions
			Min	Typ	Max	Min	Max		
Propagation delay time	t_{PHL}	2.0	—	—	90	—	115	ns	
		4.5	—	12	18	—	23		
		6.0	—	—	15	—	20		
	t_{PLH}	2.0	—	—	90	—	115	ns	
		4.5	—	10	18	—	23		
		6.0	—	—	15	—	20		
Output enable time	t_{ZL}	2.0	—	—	150	—	190	ns	
		4.5	—	11	30	—	38		
		6.0	—	—	26	—	33		
	t_{ZH}	2.0	—	—	150	—	190	ns	
		4.5	—	12	30	—	38		
		6.0	—	—	26	—	33		
Output disable time	t_{LZ}	2.0	—	—	150	—	190	ns	
		4.5	—	16	30	—	38		
		6.0	—	—	26	—	33		
	t_{HZ}	2.0	—	—	150	—	190	ns	
		4.5	—	19	30	—	38		
		6.0	—	—	26	—	33		
Output rise/fall time	t_{TLH}	2.0	—	—	60	—	75	ns	
	t_{THL}	4.5	—	4	12	—	15		
	6.0	—	—	10	—	13			
Input capacitance	C_{in}	—	—	5	10	—	10	pF	

Test Circuit

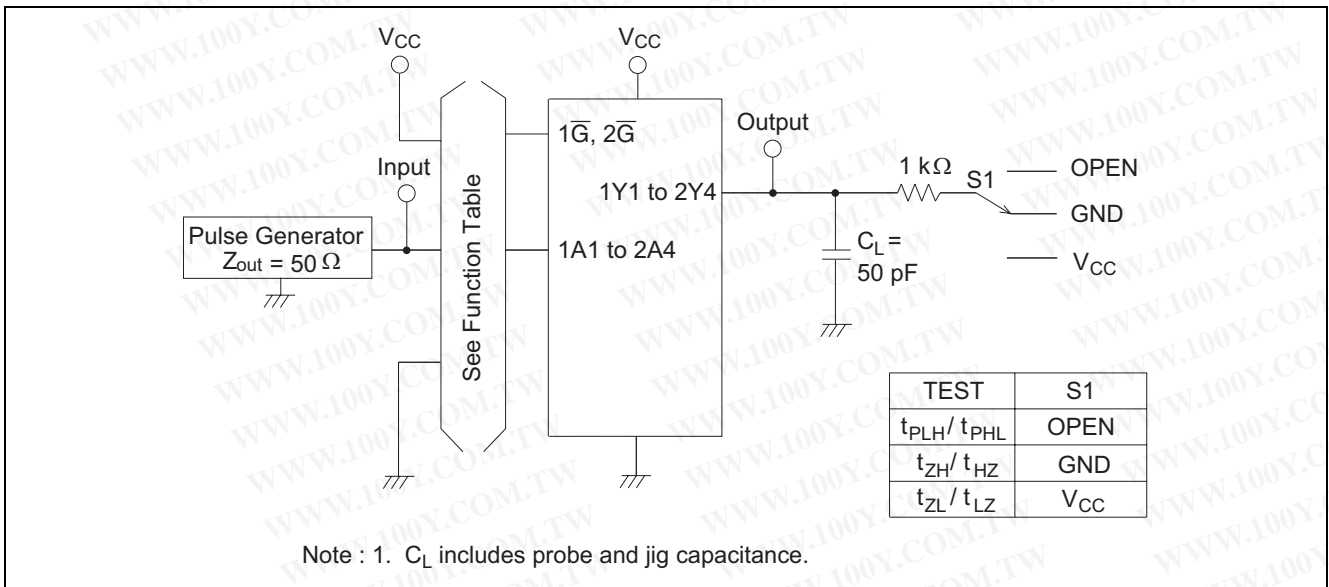

勝特力材料 886-3-5753170
 勝特力电子(上海) 86-21-34970699
 勝特力电子(深圳) 86-755-83298787
[Http://www.100y.com.tw](http://www.100y.com.tw)

Waveforms

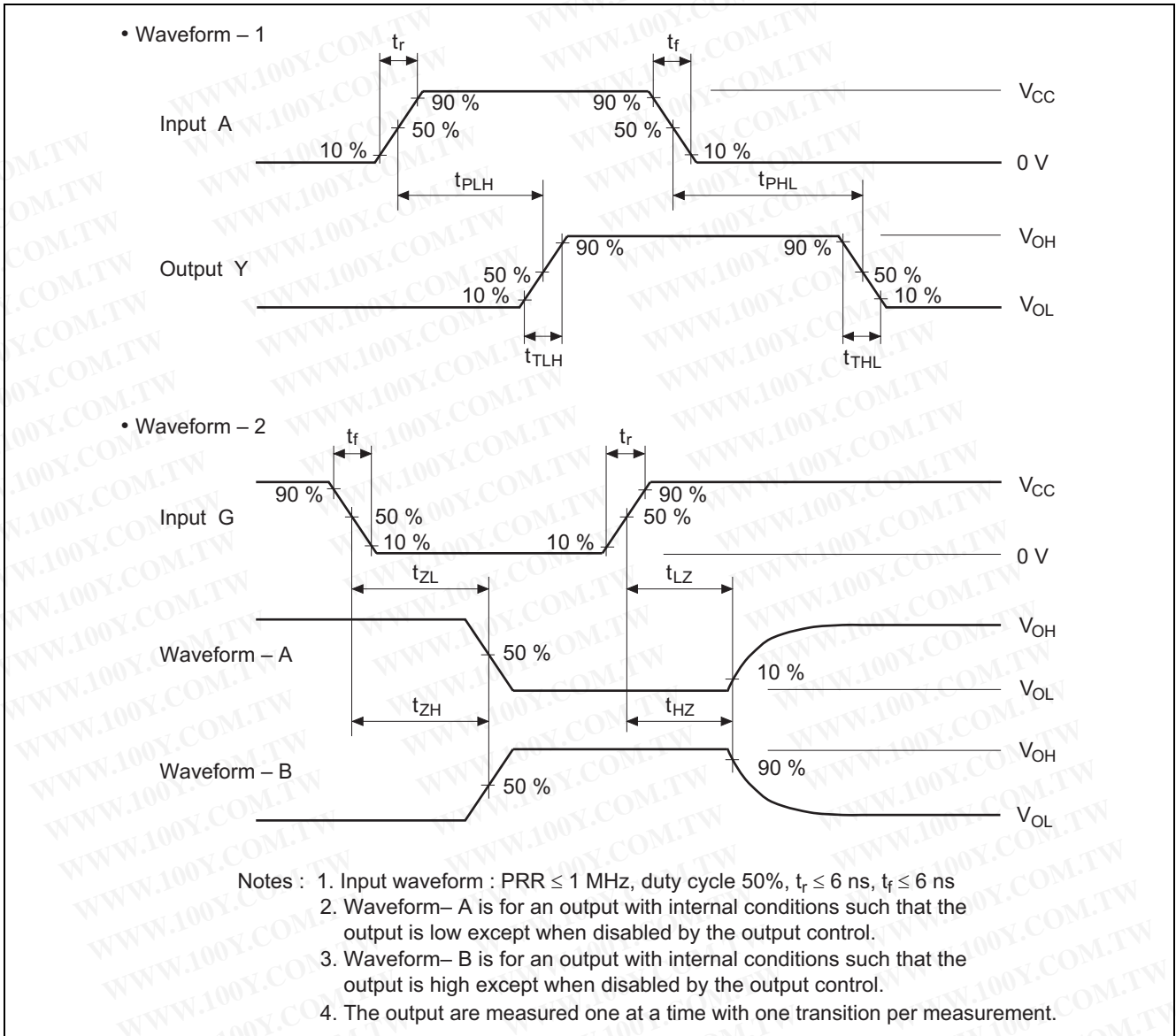

勝特力材料 886-3-5753170
勝特力电子(上海) 86-21-34970699
勝特力电子(深圳) 86-755-83298787
[Http://www.100y.com.tw](http://www.100y.com.tw)

Package Dimensions

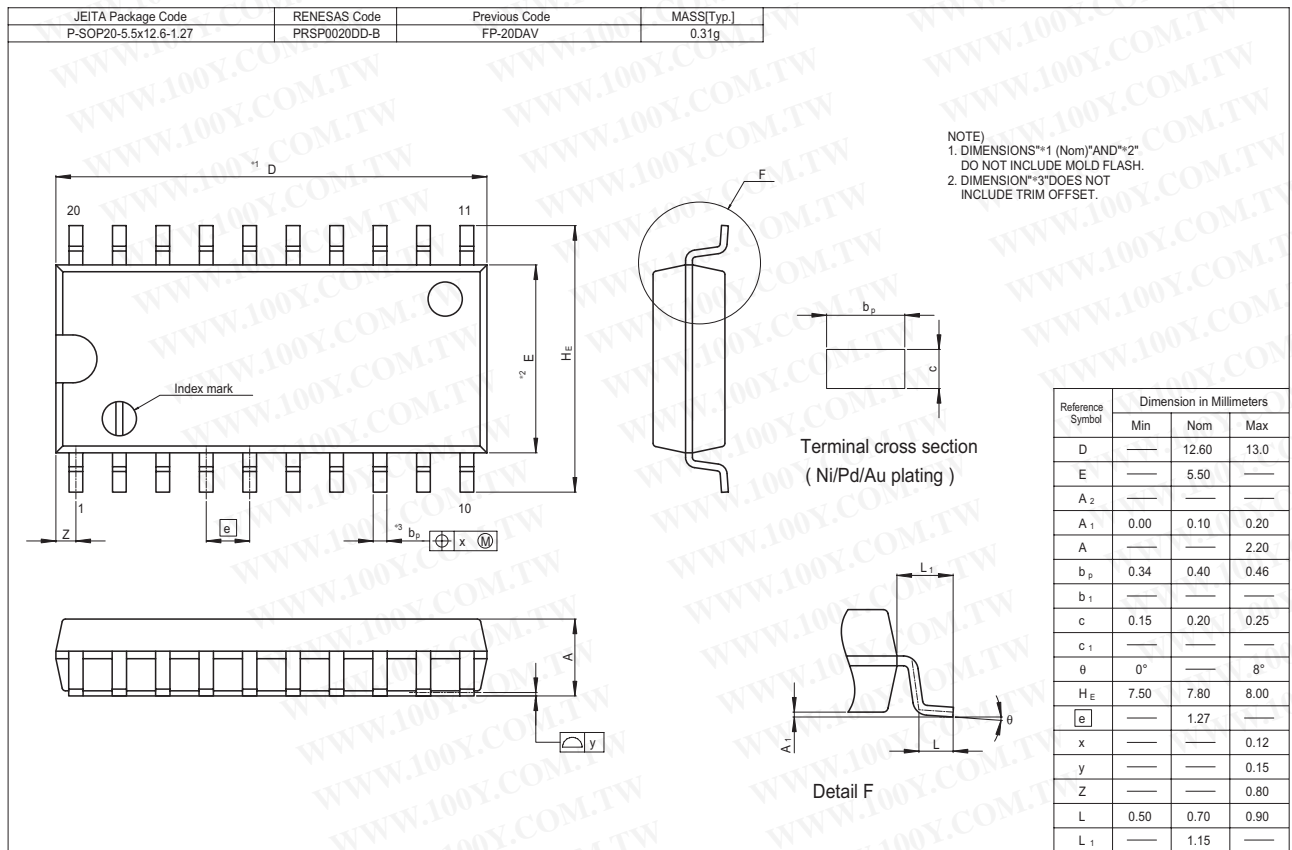
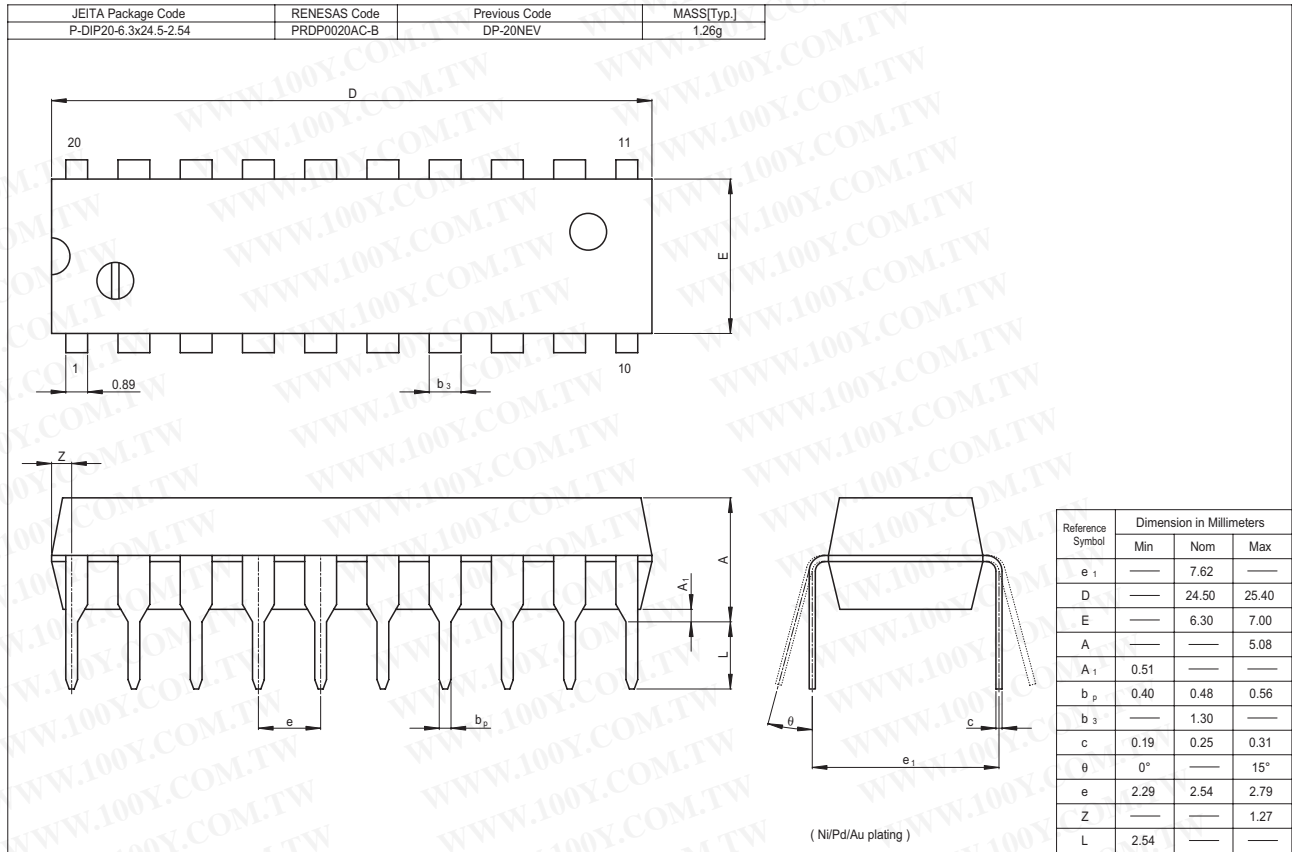

HD74HC244

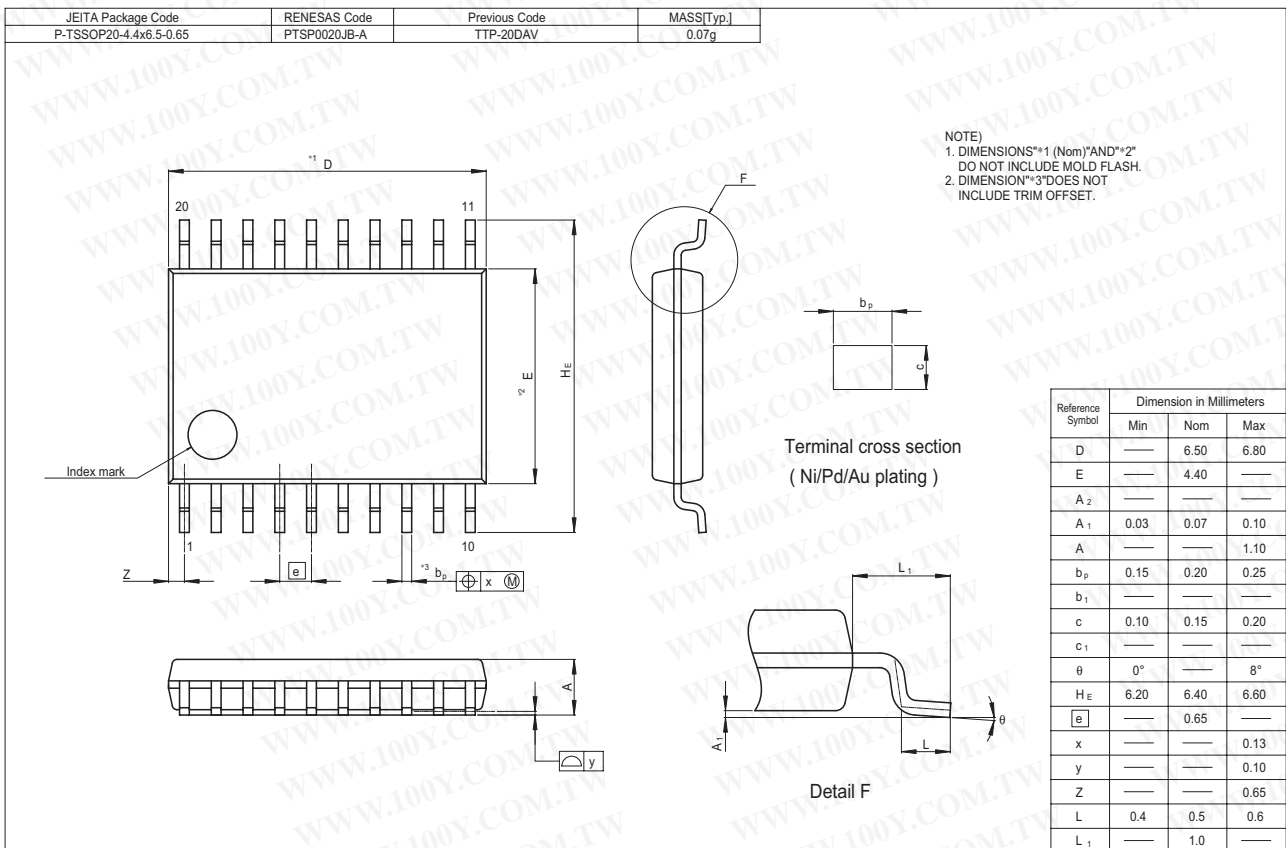
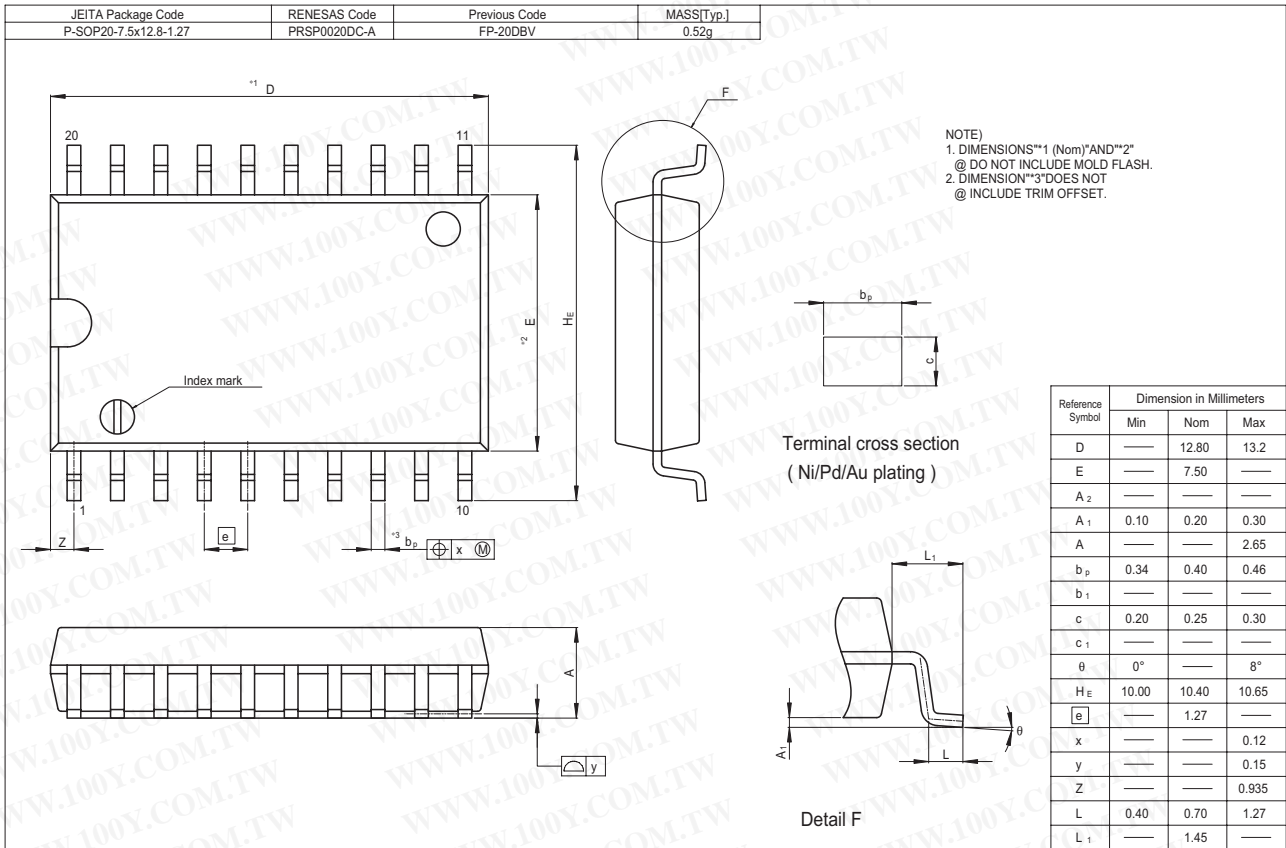

勝特力材料 886-3-5753170
勝特力电子(上海) 86-21-34970699
勝特力电子(深圳) 86-755-83298787
[Http://www.100y.com.tw](http://www.100y.com.tw)