

HEF4053B

Triple single-pole double-throw analog switch

Rev. 09 — 25 March 2010

Product data sheet

1. General description

The HEF4053B is a triple single-pole double-throw (SPDT) analog switch, suitable for use as an analog or digital multiplexer/demultiplexer. Each switch has a digital select input (S_n), two independent inputs/outputs (nY_0 and nY_1) and a common input/output (nZ). All three switches share an enable input (\bar{E}). A HIGH on \bar{E} causes all switches into the high-impedance OFF-state, independent of S_n .

V_{DD} and V_{SS} are the supply voltage connections for the digital control inputs (S_n and \bar{E}). The V_{DD} to V_{SS} range is 3 V to 15 V. The analog inputs/outputs (nY_0 , nY_1 and nZ) can swing between V_{DD} as a positive limit and V_{EE} as a negative limit. $V_{DD} - V_{EE}$ may not exceed 15 V. Unused inputs must be connected to V_{DD} , V_{SS} , or another input. For operation as a digital multiplexer/demultiplexer, V_{EE} is connected to V_{SS} (typically ground). V_{EE} and V_{SS} are the supply voltage connections for the switches.

The HEF4053B is suitable for use over both the industrial ($-40\text{ }^\circ\text{C}$ to $+85\text{ }^\circ\text{C}$) and automotive ($-40\text{ }^\circ\text{C}$ to $+125\text{ }^\circ\text{C}$) temperature ranges.

2. Features and benefits

- Fully static operation
- 5 V, 10 V, and 15 V parametric ratings
- Standardized symmetrical output characteristics
- Operates across the automotive temperature range $-40\text{ }^\circ\text{C}$ to $+125\text{ }^\circ\text{C}$
- Complies with JEDEC standard JESD 13-B

3. Applications

- Industrial and automotive
- Analog multiplexing and demultiplexing
- Digital multiplexing and demultiplexing
- Signal gating

勝特力材料 886-3-5753170
勝特力电子(上海) 86-21-34970699
勝特力电子(深圳) 86-755-83298787
[Http://www.100y.com.tw](http://www.100y.com.tw)



4. Ordering information

Table 1. Ordering information
All types operate from -40 °C to +125 °C.

Type number	Package		Version
	Name	Description	
HEF4053BP	DIP16	plastic dual in-line package; 16 leads (300 mil)	SOT38-4
HEF4053BT	SO16	plastic small outline package; 16 leads; body width 3.9 mm	SOT109-1
HEF4053BTT	TSSOP16	plastic thin shrink small outline package; 16 leads; body width 4.4 mm	SOT403-1

5. Functional diagram

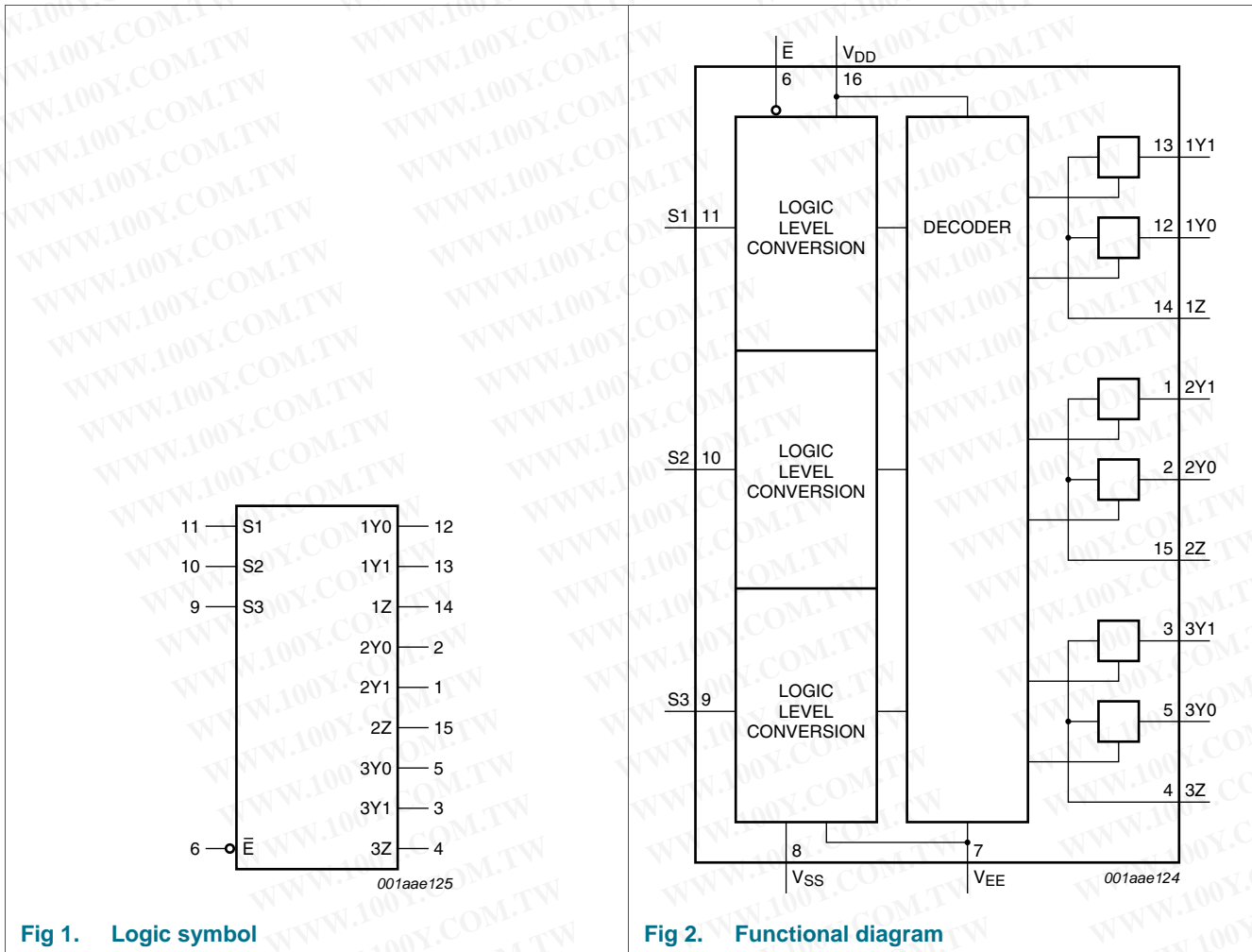

勝特力材料 886-3-5753170
勝特力电子(上海) 86-21-34970699
勝特力电子(深圳) 86-755-83298787
[Http://www.100y.com.tw](http://www.100y.com.tw)

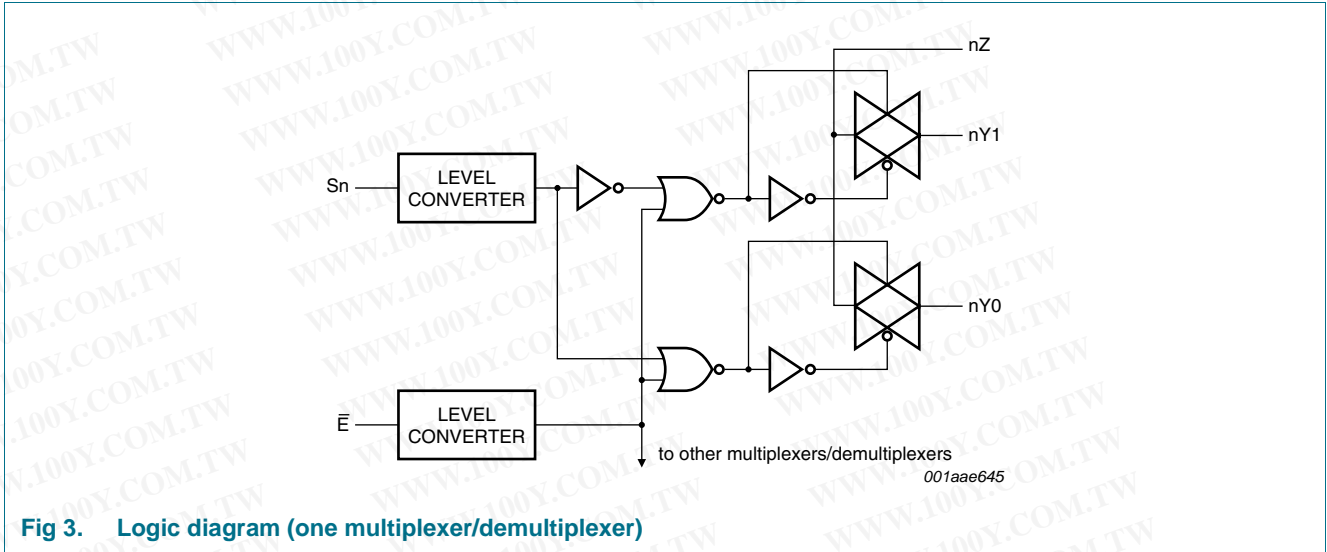

Fig 3. Logic diagram (one multiplexer/demultiplexer)

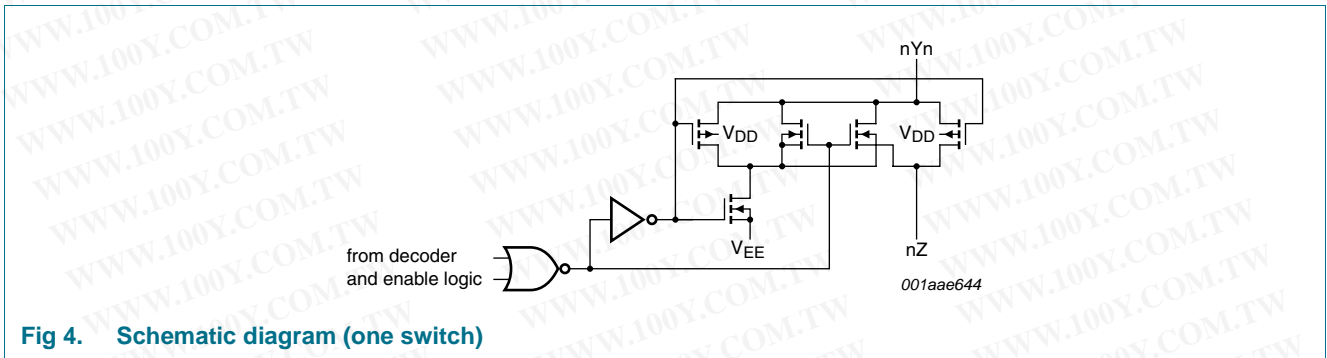

Fig 4. Schematic diagram (one switch)

勝特力材料 886-3-5753170
 勝特力电子(上海) 86-21-34970699
 勝特力电子(深圳) 86-755-83298787
[Http://www.100y.com.tw](http://www.100y.com.tw)

6. Pinning information

勝特力材料 886-3-5753170
 勝特力电子(上海) 86-21-34970699
 勝特力电子(深圳) 86-755-83298787
 Http://www.100y.com.tw

6.1 Pinning

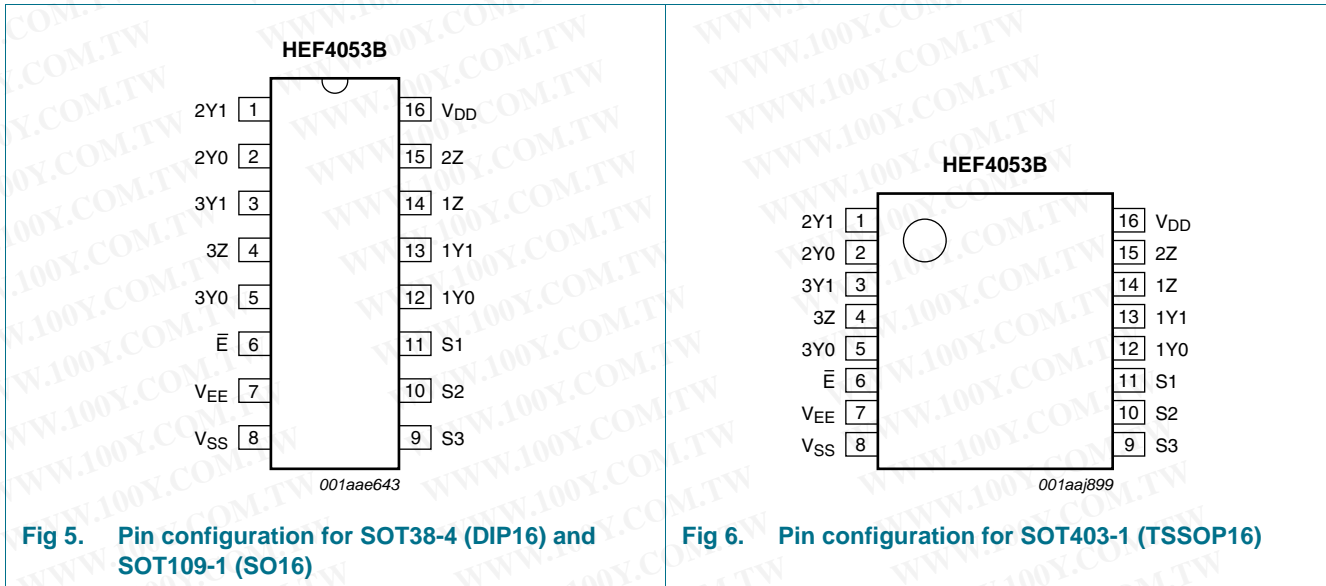

6.2 Pin description

Table 2. Pin description

Symbol	Pin	Description
\bar{E}	6	enable input (active LOW)
V_{EE}	7	supply voltage
V_{SS}	8	ground supply voltage
S1, S2, S3	11, 10, 9	select input
1Y0, 2Y0, 3Y0	12, 2, 5	independent input or output
1Y1, 2Y1, 3Y1	13, 1, 3	independent input or output
1Z, 2Z, 3Z	14, 15, 4	independent output or input
V_{DD}	16	supply voltage

7. Functional description

Table 3. Function table [1]

Inputs		Channel on
\bar{E}	Sn	
L	L	nY0 to nZ
L	H	nY1 to nZ
H	X	switches OFF

[1] H = HIGH voltage level; L = LOW voltage level; X = don't care.

8. Limiting values

Table 4. Limiting values

In accordance with the Absolute Maximum Rating System (IEC 60134). Voltages are referenced to $V_{SS} = 0\text{ V}$ (ground).

Symbol	Parameter	Conditions	Min	Max	Unit
V_{DD}	supply voltage		-0.5	+18	V
V_{EE}	supply voltage	referenced to V_{DD}	[1] -18	+0.5	V
I_{IK}	input clamping current	pins Sn and \bar{E} ; $V_I < -0.5\text{ V}$ or $V_I > V_{DD} + 0.5\text{ V}$	-	± 10	mA
V_I	input voltage		-0.5	$V_{DD} + 0.5$	V
$I_{I/O}$	input/output current		-	± 10	mA
I_{DD}	supply current		-	50	mA
T_{stg}	storage temperature		-65	+150	°C
T_{amb}	ambient temperature		-40	+125	°C
P_{tot}	total power dissipation	$T_{amb} = -40\text{ °C}$ to $+125\text{ °C}$	[2]		
		DIP16 package	-	750	mW
		SO16 package	-	500	mW
		TSSOP16 package	-	500	mW
P	power dissipation	per output	-	100	mW

- [1] To avoid drawing V_{DD} current out of terminal Z, when switch current flows into terminals Y, the voltage drop across the bidirectional switch must not exceed 0.4 V. If the switch current flows into terminal Z, no V_{DD} current will flow out of terminals Y, and in this case there is no limit for the voltage drop across the switch, but the voltages at Y and Z may not exceed V_{DD} or V_{EE} .
- [2] For DIP16 package: P_{tot} derates linearly with 12 mW/K above 70 °C.
 For SO16 package: P_{tot} derates linearly with 8 mW/K above 70 °C.
 For TSSOP16 package: P_{tot} derates linearly with 5.5 mW/K above 60 °C.

9. Recommended operating conditions

Table 5. Recommended operating conditions

Symbol	Parameter	Conditions	Min	Typ	Max	Unit
V_{DD}	supply voltage	see Figure 7	3	-	15	V
V_I	input voltage		0	-	V_{DD}	V
T_{amb}	ambient temperature	in free air	-40	-	+125	°C
$\Delta t/\Delta V$	input transition rise and fall rate	$V_{DD} = 5\text{ V}$	-	-	3.75	$\mu\text{s/V}$
		$V_{DD} = 10\text{ V}$	-	-	0.5	$\mu\text{s/V}$
		$V_{DD} = 15\text{ V}$	-	-	0.08	$\mu\text{s/V}$

勝特力材料 886-3-5753170
 勝特力电子(上海) 86-21-34970699
 勝特力电子(深圳) 86-755-83298787
[Http://www.100y.com.tw](http://www.100y.com.tw)

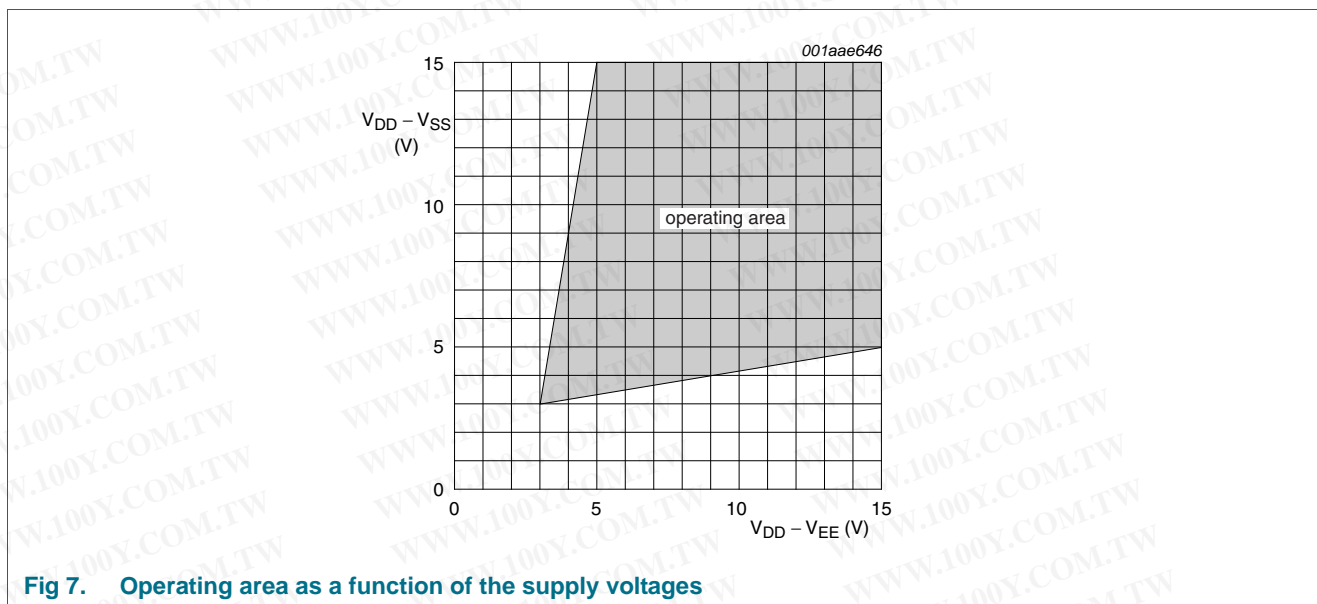

Fig 7. Operating area as a function of the supply voltages

10. Static characteristics

Table 6. Static characteristics

$V_{SS} = V_{EE} = 0$ V; $V_I = V_{SS}$ or V_{DD} unless otherwise specified.

Symbol	Parameter	Conditions	V_{DD}	$T_{amb} = -40$ °C		$T_{amb} = 25$ °C		$T_{amb} = 85$ °C		$T_{amb} = 125$ °C		Unit
				Min	Max	Min	Max	Min	Max	Min	Max	
V_{IH}	HIGH-level input voltage	$ I_O < 1$ μ A	5 V	3.5	-	3.5	-	3.5	-	3.5	-	V
			10 V	7.0	-	7.0	-	7.0	-	7.0	-	V
			15 V	11.0	-	11.0	-	11.0	-	11.0	-	V
V_{IL}	LOW-level input voltage	$ I_O < 1$ μ A	5 V	-	1.5	-	1.5	-	1.5	-	1.5	V
			10 V	-	3.0	-	3.0	-	3.0	-	3.0	V
			15 V	-	4.0	-	4.0	-	4.0	-	4.0	V
I_I	input leakage current		15 V	-	± 0.1	-	± 0.1	-	± 1.0	-	± 1.0	μ A
$I_{S(OFF)}$	OFF-state leakage current	Z port; all channels OFF; see Figure 8	15 V	-	-	-	1000	-	-	-	-	nA
		Y port; per channel; see Figure 9	15 V	-	-	-	200	-	-	-	-	nA
I_{DD}	supply current	$I_O = 0$ A	5 V	-	5	-	5	-	150	-	150	μ A
			10 V	-	10	-	10	-	300	-	300	μ A
			15 V	-	20	-	20	-	600	-	600	μ A
C_I	input capacitance	S_n, \bar{E} inputs	-	-	-	-	7.5	-	-	-	-	pF

10.1 Test circuits

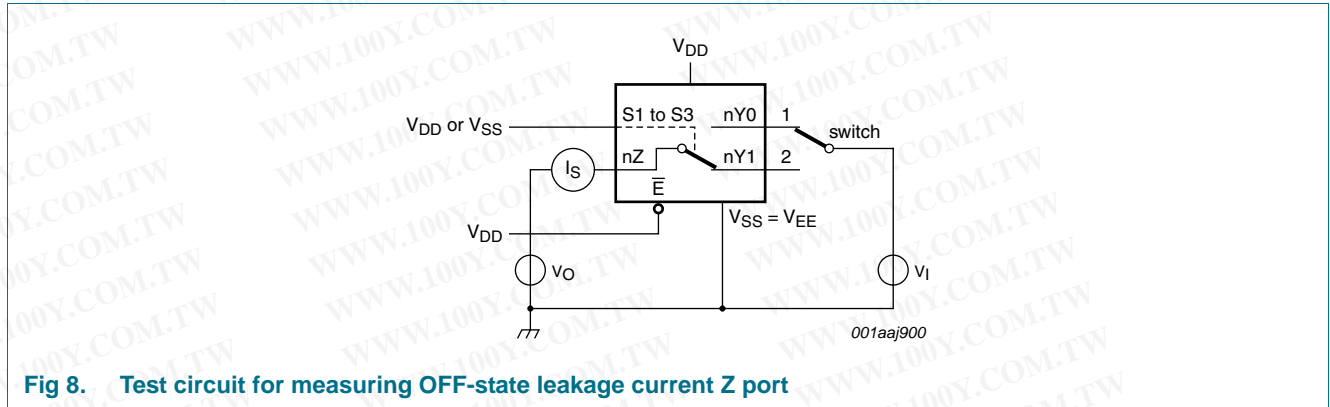

Fig 8. Test circuit for measuring OFF-state leakage current Z port

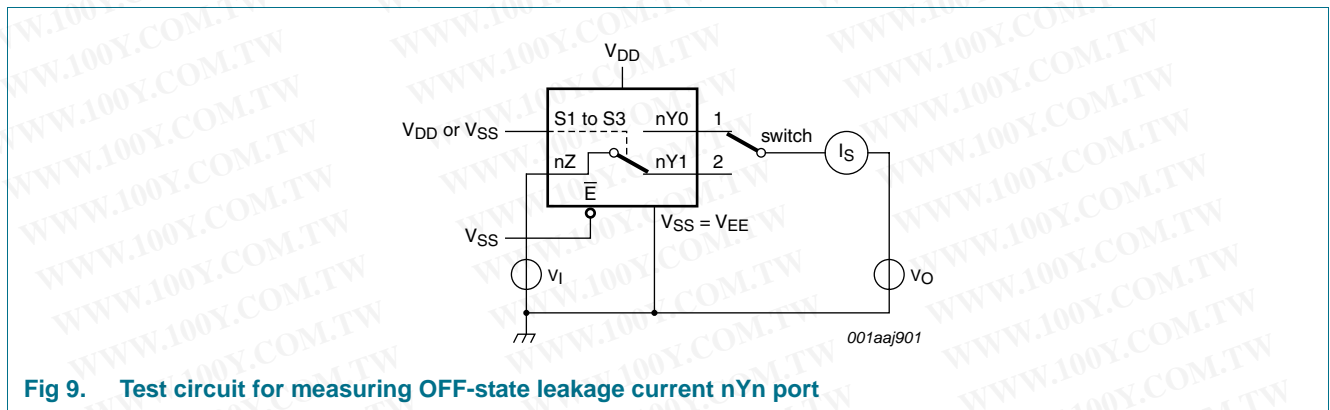

Fig 9. Test circuit for measuring OFF-state leakage current nYn port

10.2 ON resistance

Table 7. ON resistance

$T_{amb} = 25\text{ }^{\circ}\text{C}$; $I_{SW} = 200\text{ }\mu\text{A}$; $V_{SS} = V_{EE} = 0\text{ V}$.

Symbol	Parameter	Conditions	$V_{DD} - V_{EE}$	Typ	Max	Unit
$R_{ON(peak)}$	ON resistance (peak)	$V_I = 0\text{ V to }V_{DD} - V_{EE}$; see Figure 10 and Figure 11	5 V	350	2500	Ω
			10 V	80	245	Ω
			15 V	60	175	Ω
$R_{ON(rail)}$	ON resistance (rail)	$V_I = 0\text{ V}$; see Figure 10 and Figure 11	5 V	115	340	Ω
			10 V	50	160	Ω
			15 V	40	115	Ω
		$V_I = V_{DD} - V_{EE}$; see Figure 10 and Figure 11	5 V	120	365	Ω
			10 V	65	200	Ω
			15 V	50	155	Ω
ΔR_{ON}	ON resistance mismatch between channels	$V_I = 0\text{ V to }V_{DD} - V_{EE}$; see Figure 10	5 V	25	-	Ω
			10 V	10	-	Ω
			15 V	5	-	Ω

10.2.1 ON resistance waveform and test circuit

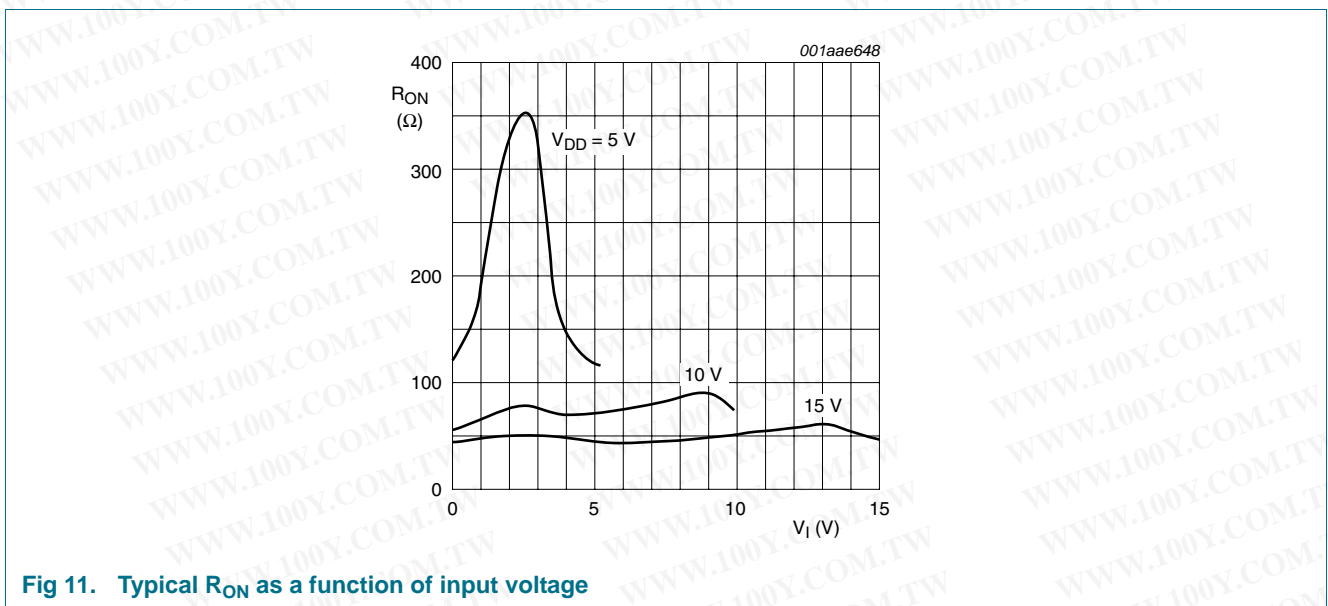
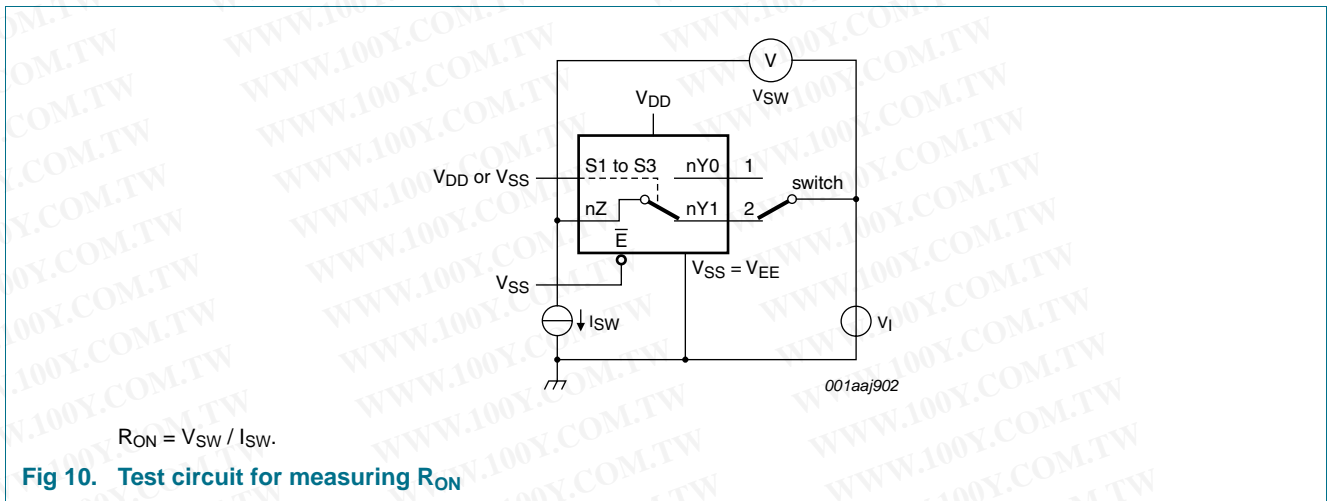

勝特力材料 886-3-5753170
 勝特力电子(上海) 86-21-34970699
 勝特力电子(深圳) 86-755-83298787
[Http://www.100y.com.tw](http://www.100y.com.tw)

11. Dynamic characteristics

Table 8. Dynamic characteristics

$T_{amb} = 25\text{ }^{\circ}\text{C}$; $V_{SS} = V_{EE} = 0\text{ V}$; for test circuit see [Figure 15](#).

Symbol	Parameter	Conditions	V_{DD}	Typ	Max	Unit
t_{PLH}	HIGH to LOW propagation delay	nYn, nZ to nZ, nYn; see Figure 12	5 V	10	20	ns
			10 V	5	10	ns
			15 V	5	10	ns
		Sn to nYn, nZ; see Figure 13	5 V	200	400	ns
			10 V	85	170	ns
			15 V	65	130	ns
t_{PLH}	LOW to HIGH propagation delay	nYn, nZ to nZ, nYn; see Figure 12	5 V	15	30	ns
			10 V	5	10	ns
			15 V	5	10	ns
		Sn to nYn, nZ; see Figure 13	5 V	275	555	ns
			10 V	100	200	ns
			15 V	65	130	ns
t_{PHZ}	HIGH to OFF-state propagation delay	\bar{E} to nYn, nZ; see Figure 14	5 V	200	400	ns
			10 V	115	230	ns
			15 V	110	220	ns
t_{PZH}	OFF-state to HIGH propagation delay	\bar{E} to nYn, nZ; see Figure 14	5 V	260	525	ns
			10 V	95	190	ns
			15 V	65	130	ns
t_{PLZ}	LOW to OFF-state propagation delay	\bar{E} to nYn, nZ; see Figure 14	5 V	200	400	ns
			10 V	120	245	ns
			15 V	110	215	ns
t_{PZL}	OFF-state to LOW propagation delay	\bar{E} to nYn, nZ; see Figure 14	5 V	280	565	ns
			10 V	105	205	ns
			15 V	70	140	ns

11.1 Waveforms and test circuit

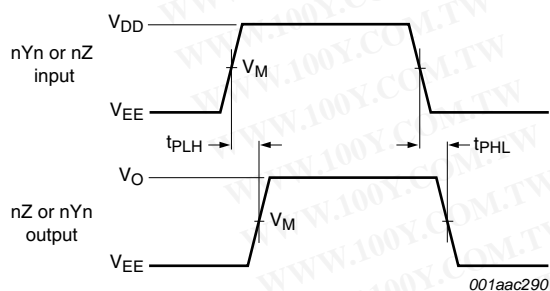

Measurement points are given in [Table 9](#).

Fig 12. nYn, nZ to nZ, nYn propagation delays

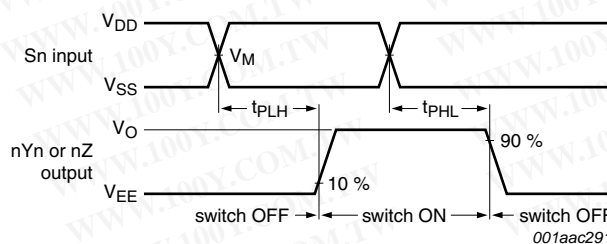

Measurement points are given in [Table 9](#).

Fig 13. Sn to nYn, nZ propagation delays

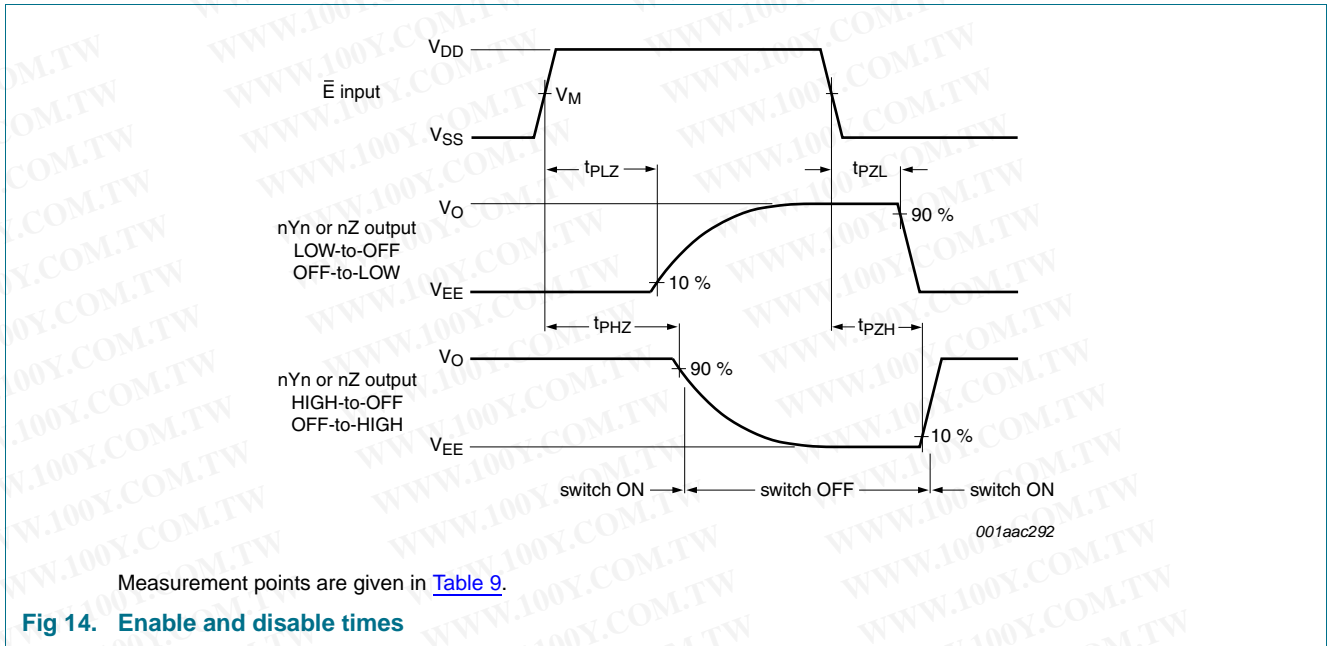

Table 9. Measurement points

Supply voltage	Input	Output
V_{DD}	V_M	V_M
5 V to 15 V	$0.5V_{DD}$	$0.5V_{DD}$

勝特力材料 886-3-5753170
 勝特力电子(上海) 86-21-34970699
 勝特力电子(深圳) 86-755-83298787
[Http://www.100y.com.tw](http://www.100y.com.tw)

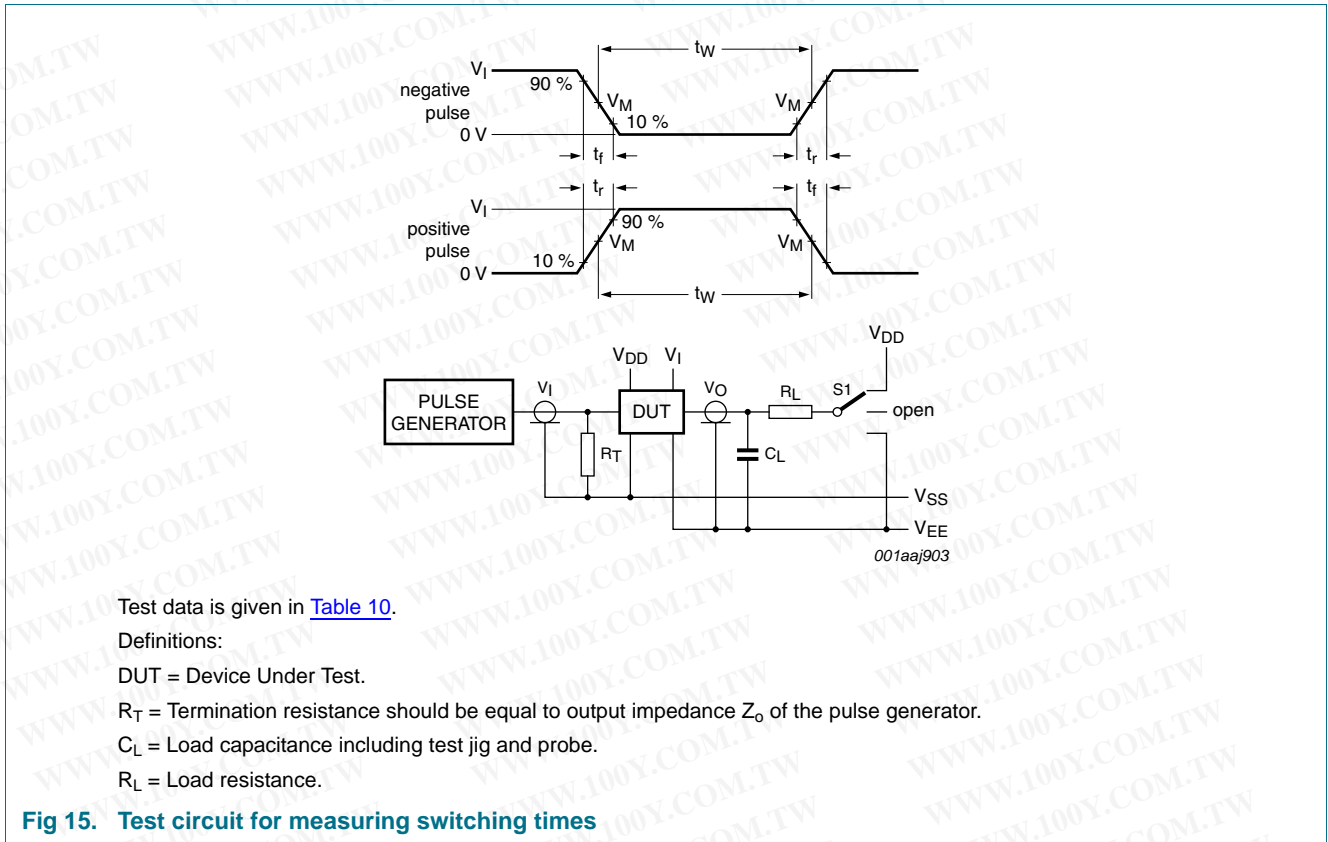

Table 10. Test data

Input				Load		S1 position				
nYn, nZ	Sn and E	t_r, t_f	V_M	C_L	R_L	t_{PHL} ^[1]	t_{PLH}	t_{PZH}, t_{PHZ}	t_{PZL}, t_{PLZ}	other
V_{DD} or V_{EE}	V_{DD} or V_{SS}	≤ 20 ns	$0.5V_{DD}$	50 pF	10 kΩ	V_{DD} or V_{EE}	V_{EE}	V_{EE}	V_{DD}	V_{EE}

[1] For nYn to nZ or nZ to nYn propagation delays use V_{EE} . For Sn to nYn or nZ propagation delays use V_{DD} .

勝特力材料 886-3-5753170
 勝特力电子(上海) 86-21-34970699
 勝特力电子(深圳) 86-755-83298787
[Http://www.100y.com.tw](http://www.100y.com.tw)

11.2 Additional dynamic parameters

Table 11. Additional dynamic characteristics

$V_{SS} = V_{EE} = 0\text{ V}$; $T_{amb} = 25\text{ }^{\circ}\text{C}$.

Symbol	Parameter	Conditions	V_{DD}	Typ	Max	Unit
THD	total harmonic distortion	see Figure 16 ; $R_L = 10\text{ k}\Omega$; $C_L = 15\text{ pF}$; channel ON; $V_i = 0.5V_{DD}$ (p-p); $f_i = 1\text{ kHz}$	5 V	[1] 0.25	-	%
			10 V	[1] 0.04	-	%
			15 V	[1] 0.04	-	%
$f_{(-3\text{dB})}$	-3 dB frequency response	see Figure 17 ; $R_L = 1\text{ k}\Omega$; $C_L = 5\text{ pF}$; channel ON; $V_i = 0.5V_{DD}$ (p-p)	5 V	[1] 13	-	MHz
			10 V	[1] 40	-	MHz
			15 V	[1] 70	-	MHz
α_{iso}	isolation (OFF-state)	see Figure 18 ; $f_i = 1\text{ MHz}$; $R_L = 1\text{ k}\Omega$; $C_L = 5\text{ pF}$; channel OFF; $V_i = 0.5V_{DD}$ (p-p)	10 V	[1] -50	-	dB
V_{ct}	crosstalk voltage	digital inputs to switch; see Figure 19 ; $R_L = 10\text{ k}\Omega$; $C_L = 15\text{ pF}$; E or $\text{Sn} = V_{DD}$ (square-wave)	10 V	50	-	mV
Xtalk	crosstalk	between switches; see Figure 20 ; $f_i = 1\text{ MHz}$; $R_L = 1\text{ k}\Omega$; $V_i = 0.5V_{DD}$ (p-p)	10 V	[1] -50	-	dB

[1] f_i is biased at $0.5 V_{DD}$; $V_i = 0.5V_{DD}$ (p-p).

Table 12. Dynamic power dissipation P_D

P_D can be calculated from the formulas shown; $V_{EE} = V_{SS} = 0\text{ V}$; $t_r = t_f \leq 20\text{ ns}$; $T_{amb} = 25\text{ }^{\circ}\text{C}$.

Symbol	Parameter	V_{DD}	Typical formula for P_D (μW)	where:
P_D	dynamic power dissipation	5 V	$P_D = 2500 \times f_i + \Sigma(f_o \times C_L) \times V_{DD}^2$	f_i = input frequency in MHz;
		10 V	$P_D = 11500 \times f_i + \Sigma(f_o \times C_L) \times V_{DD}^2$	f_o = output frequency in MHz;
		15 V	$P_D = 29000 \times f_i + \Sigma(f_o \times C_L) \times V_{DD}^2$	C_L = output load capacitance in pF;
				V_{DD} = supply voltage in V;
				$\Sigma(C_L \times f_o)$ = sum of the outputs.

11.2.1 Test circuits

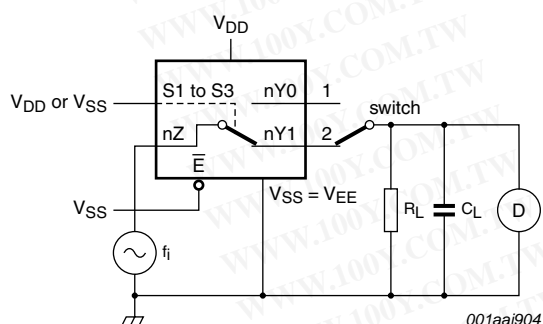

Fig 16. Test circuit for measuring total harmonic distortion

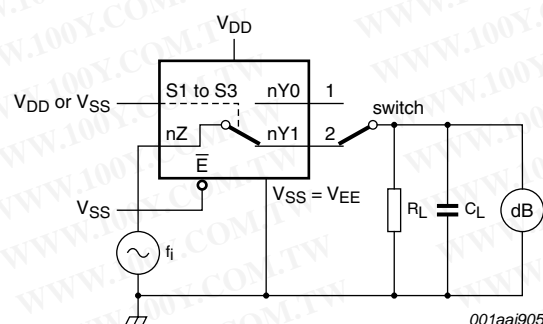

Fig 17. Test circuit for measuring frequency response

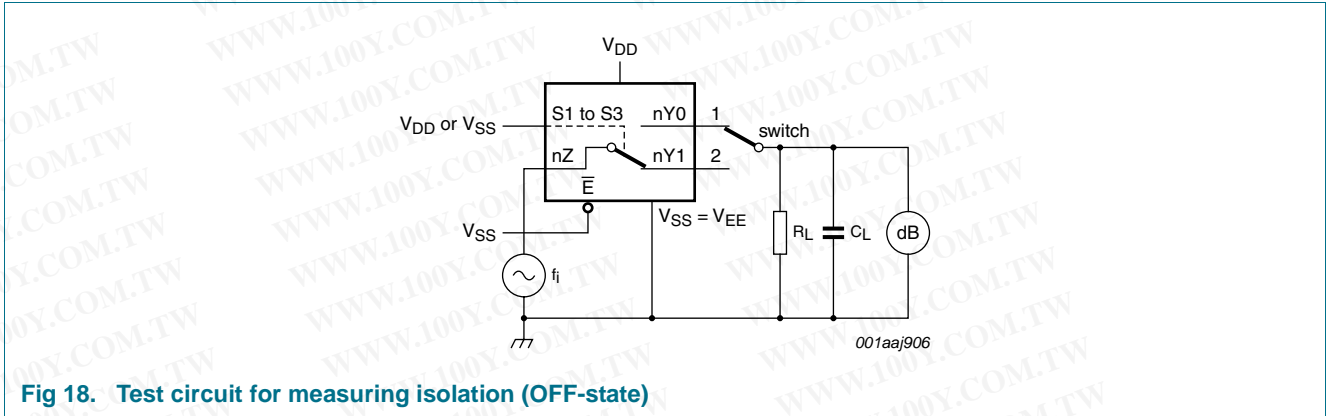

Fig 18. Test circuit for measuring isolation (OFF-state)

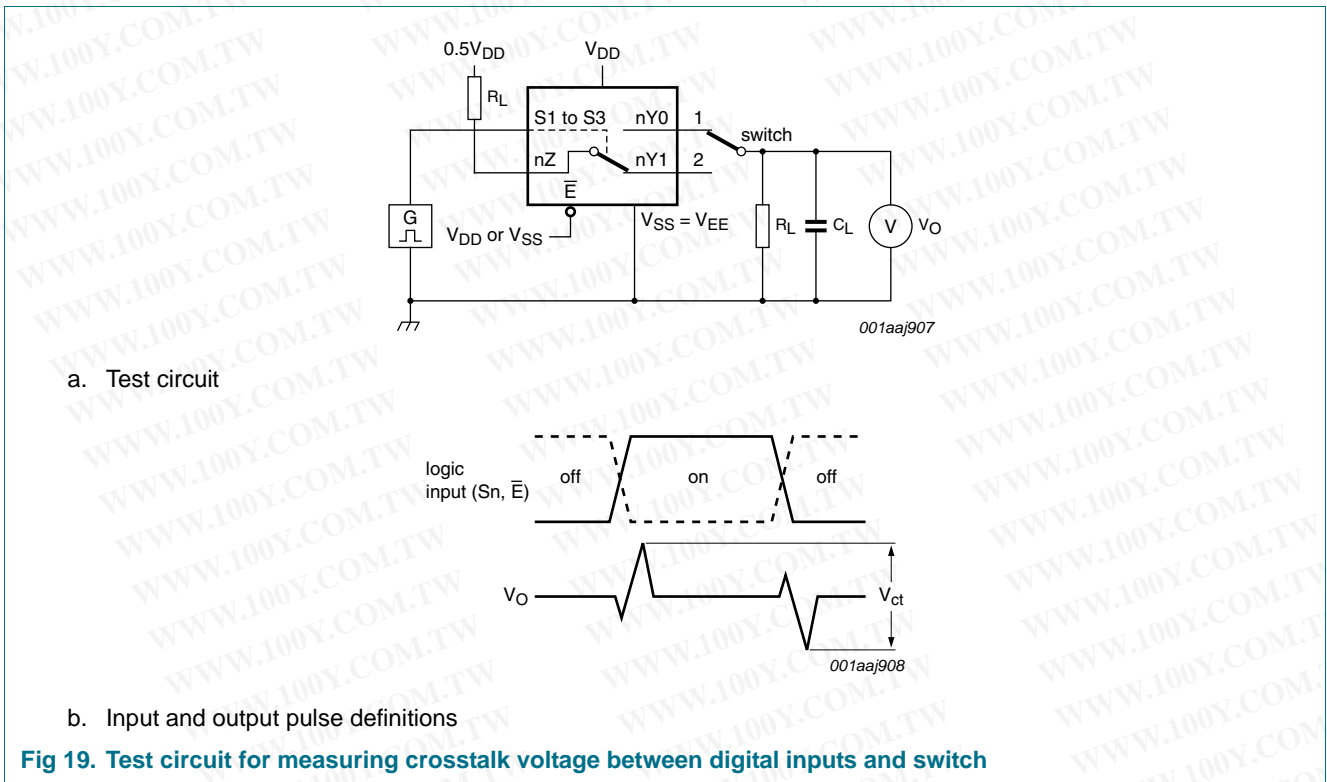
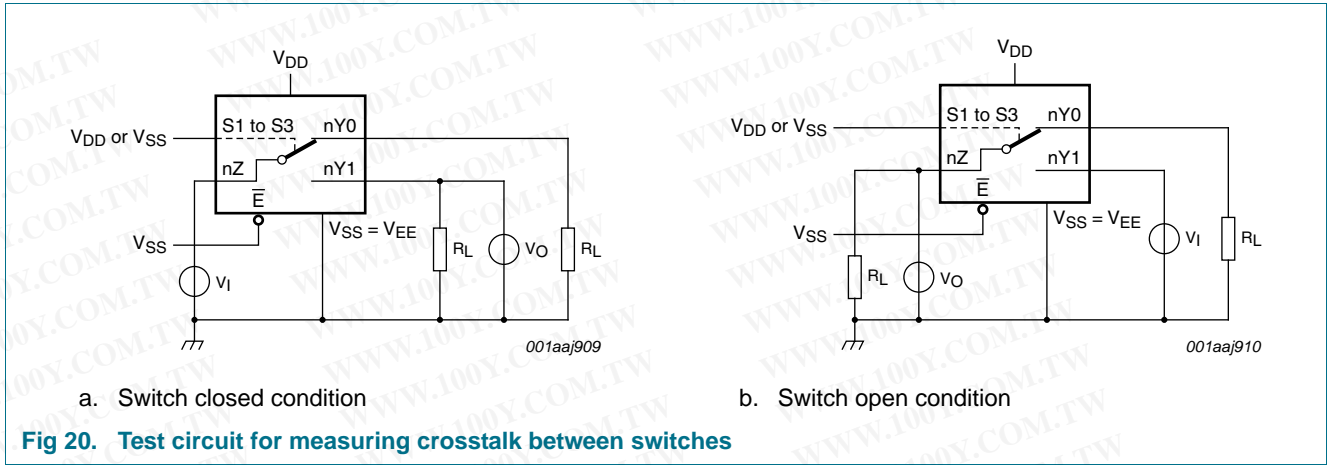

Fig 19. Test circuit for measuring crosstalk voltage between digital inputs and switch

勝特力材料 886-3-5753170
 勝特力电子(上海) 86-21-34970699
 勝特力电子(深圳) 86-755-83298787
[Http://www.100y.com.tw](http://www.100y.com.tw)



勝特力材料 886-3-5753170
勝特力电子(上海) 86-21-34970699
勝特力电子(深圳) 86-755-83298787
[Http://www.100y.com.tw](http://www.100y.com.tw)

12. Package outline

DIP16: plastic dual in-line package; 16 leads (300 mil)

SOT38-4

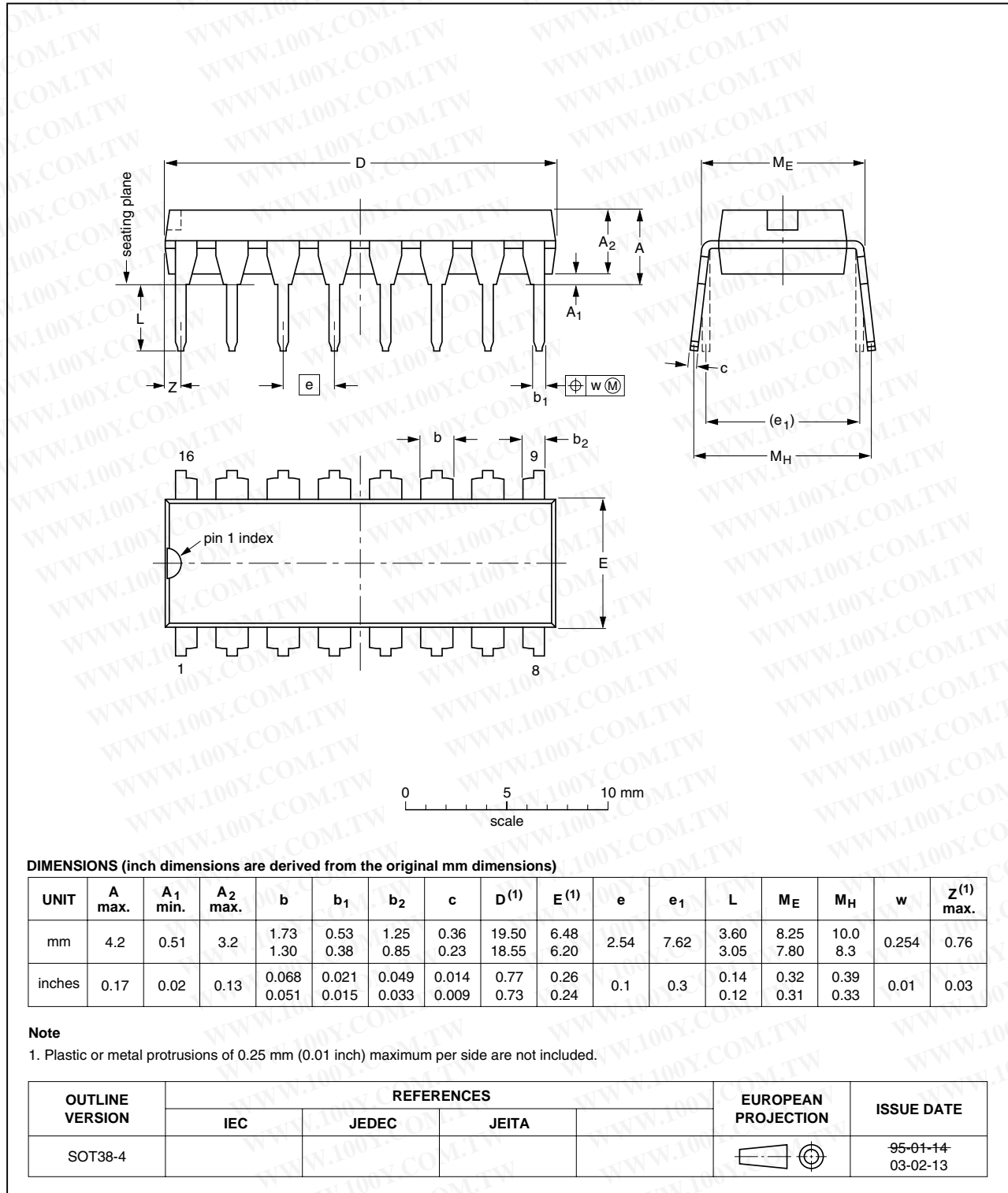

Fig 21. Package outline SOT38-4 (DIP16)

勝特力材料 886-3-5753170
 勝特力电子(上海) 86-21-34970699
 勝特力电子(深圳) 86-755-83298787
 Http://www.100y.com.tw

SO16: plastic small outline package; 16 leads; body width 3.9 mm

SOT109-1

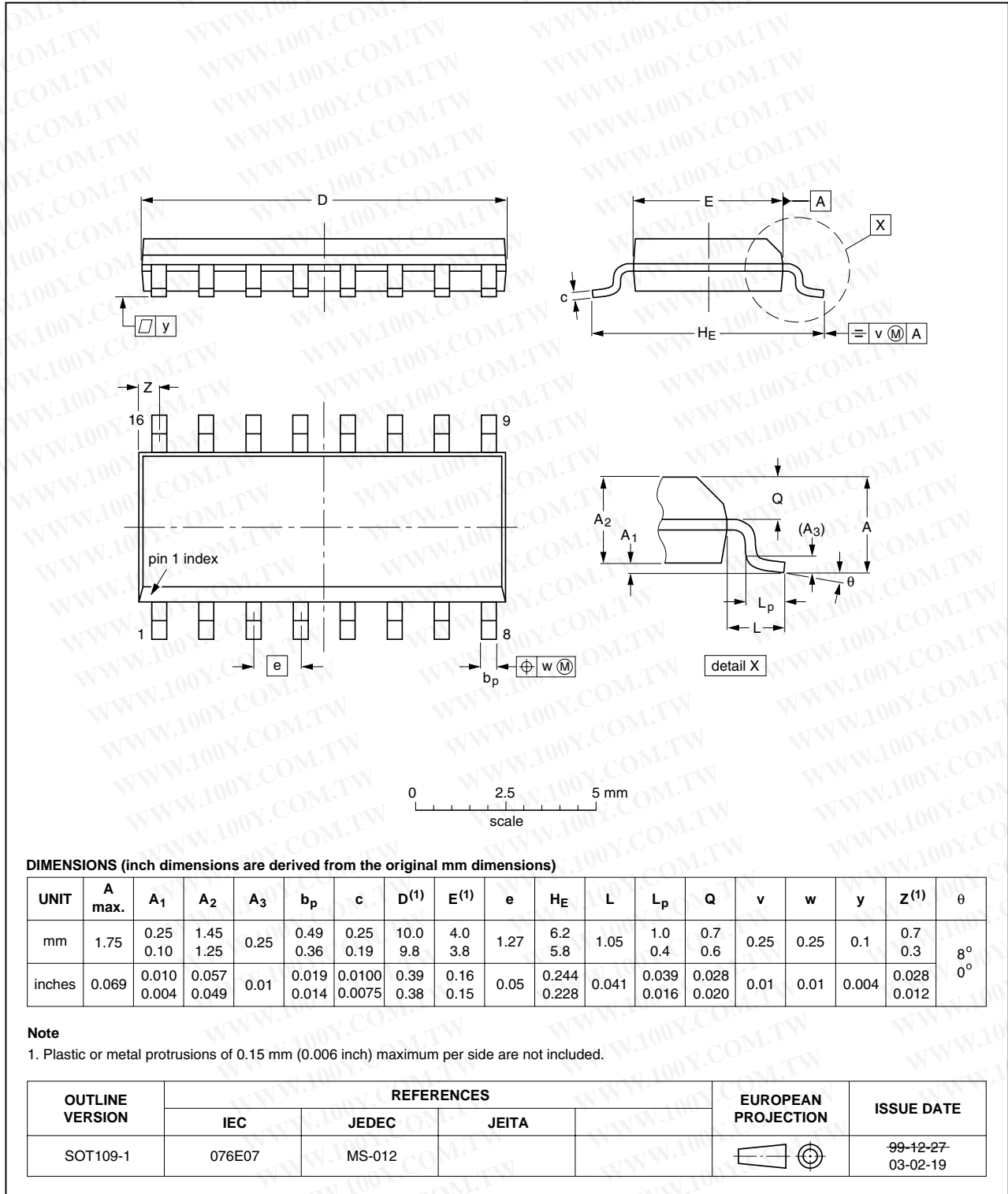

Fig 22. Package outline SOT109-1 (SO16)

勝特力材料 886-3-5753170
 勝特力电子(上海) 86-21-34970699
 勝特力电子(深圳) 86-755-83298787
 Http://www.100y.com.tw

TSSOP16: plastic thin shrink small outline package; 16 leads; body width 4.4 mm

SOT403-1

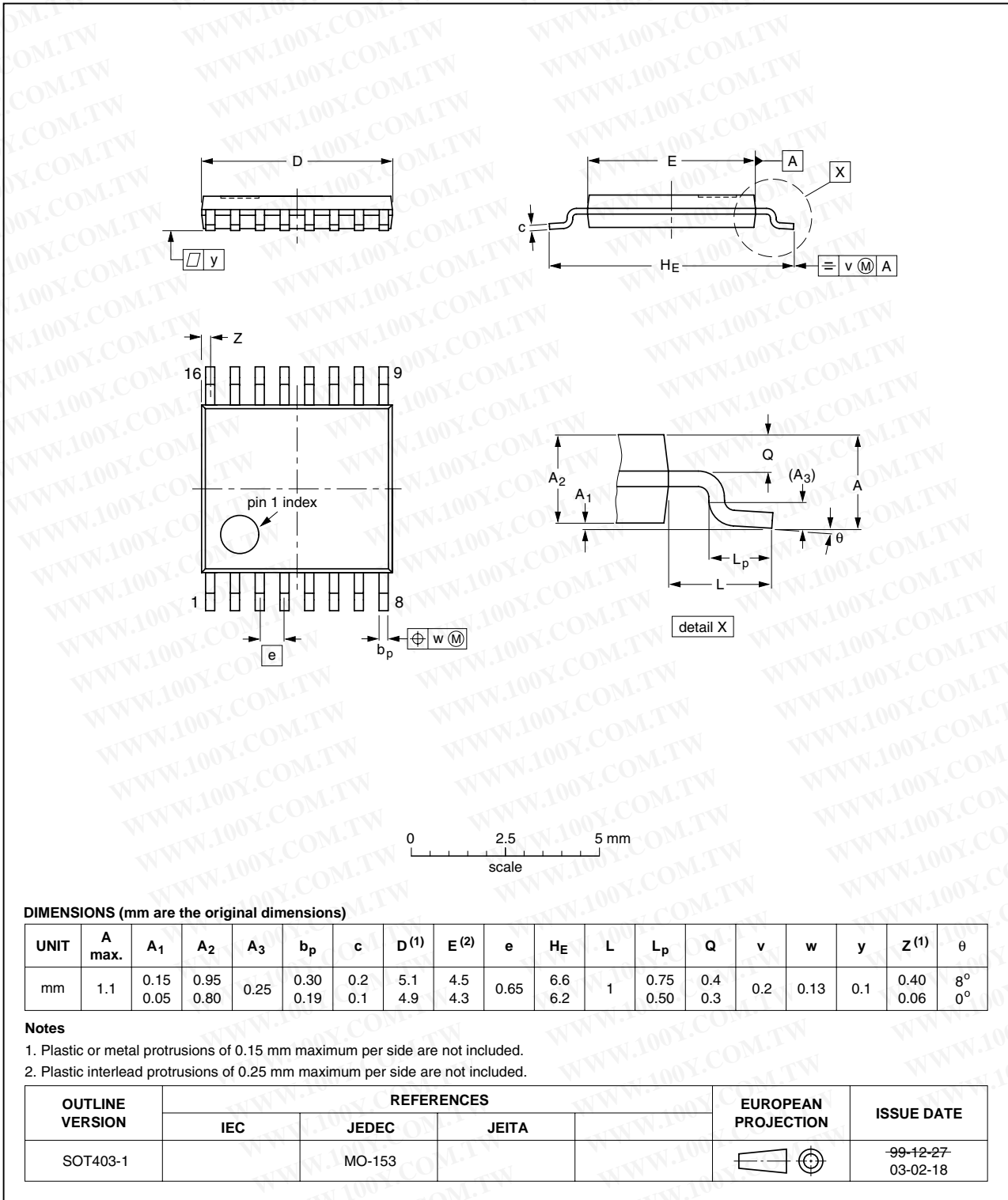

Fig 23. Package outline SOT403-1 (TSSOP16)

13. Revision history

Table 13. Revision history

Document ID	Release date	Data sheet status	Change notice	Supersedes
HEF4053B_9	20100325	Product data sheet	-	HEF4053B_8
HEF4053B_8	20100224	Product data sheet	-	HEF4053B_7
Modifications:	<ul style="list-style-type: none"> Table 6 "Static characteristics": Conditions V_{IL} and V_{IH} corrected. 			
HEF4053B_7	20091127	Product data sheet	-	HEF4053B_6
HEF4053B_6	20090924	Product data sheet	-	HEF4053B_5
HEF4053B_5	20090825	Product data sheet	-	HEF4053B_4
HEF4053B_4	20090713	Product data sheet	-	HEF4053B_CNV_3
HEF4053B_CNV_3	19950101	Product specification	-	HEF4053B_CNV_2
HEF4053B_CNV_2	19950101	Product specification	-	-

勝特力材料 886-3-5753170
 勝特力电子(上海) 86-21-34970699
 勝特力电子(深圳) 86-755-83298787
[Http://www.100y.com.tw](http://www.100y.com.tw)

勝特力材料 886-3-5753170
 勝特力电子(上海) 86-21-34970699
 勝特力电子(深圳) 86-755-83298787
[Http://www.100y.com.tw](http://www.100y.com.tw)

14. Legal information

14.1 Data sheet status

Document status ^{[1][2]}	Product status ^[3]	Definition
Objective [short] data sheet	Development	This document contains data from the objective specification for product development.
Preliminary [short] data sheet	Qualification	This document contains data from the preliminary specification.
Product [short] data sheet	Production	This document contains the product specification.

[1] Please consult the most recently issued document before initiating or completing a design.

[2] The term 'short data sheet' is explained in section "Definitions".

[3] The product status of device(s) described in this document may have changed since this document was published and may differ in case of multiple devices. The latest product status information is available on the Internet at URL.

14.2 Definitions

Draft — The document is a draft version only. The content is still under internal review and subject to formal approval, which may result in modifications or additions. NXP Semiconductors does not give any representations or warranties as to the accuracy or completeness of information included herein and shall have no liability for the consequences of use of such information.

Short data sheet — A short data sheet is an extract from a full data sheet with the same product type number(s) and title. A short data sheet is intended for quick reference only and should not be relied upon to contain detailed and full information. For detailed and full information see the relevant full data sheet, which is available on request via the local NXP Semiconductors sales office. In case of any inconsistency or conflict with the short data sheet, the full data sheet shall prevail.

Product specification — The information and data provided in a Product data sheet shall define the specification of the product as agreed between NXP Semiconductors and its customer, unless NXP Semiconductors and customer have explicitly agreed otherwise in writing. In no event however, shall an agreement be valid in which the NXP Semiconductors product is deemed to offer functions and qualities beyond those described in the Product data sheet.

14.3 Disclaimers

Limited warranty and liability — Information in this document is believed to be accurate and reliable. However, NXP Semiconductors does not give any representations or warranties, expressed or implied, as to the accuracy or completeness of such information and shall have no liability for the consequences of use of such information.

In no event shall NXP Semiconductors be liable for any indirect, incidental, punitive, special or consequential damages (including - without limitation - lost profits, lost savings, business interruption, costs related to the removal or replacement of any products or rework charges) whether or not such damages are based on tort (including negligence), warranty, breach of contract or any other legal theory.

Notwithstanding any damages that customer might incur for any reason whatsoever, NXP Semiconductors' aggregate and cumulative liability towards customer for the products described herein shall be limited in accordance with the *Terms and conditions of commercial sale* of NXP Semiconductors.

Right to make changes — NXP Semiconductors reserves the right to make changes to information published in this document, including without limitation specifications and product descriptions, at any time and without notice. This document supersedes and replaces all information supplied prior to the publication hereof.

Suitability for use in automotive applications — This NXP Semiconductors product has been qualified for use in automotive applications. The product is not designed, authorized or warranted to be

suitable for use in medical, military, aircraft, space or life support equipment, nor in applications where failure or malfunction of an NXP Semiconductors product can reasonably be expected to result in personal injury, death or severe property or environmental damage. NXP Semiconductors accepts no liability for inclusion and/or use of NXP Semiconductors products in such equipment or applications and therefore such inclusion and/or use is at the customer's own risk.

Applications — Applications that are described herein for any of these products are for illustrative purposes only. NXP Semiconductors makes no representation or warranty that such applications will be suitable for the specified use without further testing or modification.

NXP Semiconductors does not accept any liability related to any default, damage, costs or problem which is based on a weakness or default in the customer application/use or the application/use of customer's third party customer(s) (hereinafter both referred to as "Application"). It is customer's sole responsibility to check whether the NXP Semiconductors product is suitable and fit for the Application planned. Customer has to do all necessary testing for the Application in order to avoid a default of the Application and the product. NXP Semiconductors does not accept any liability in this respect.

Limiting values — Stress above one or more limiting values (as defined in the Absolute Maximum Ratings System of IEC 60134) will cause permanent damage to the device. Limiting values are stress ratings only and (proper) operation of the device at these or any other conditions above those given in the Recommended operating conditions section (if present) or the Characteristics sections of this document is not warranted. Constant or repeated exposure to limiting values will permanently and irreversibly affect the quality and reliability of the device.

Terms and conditions of commercial sale — NXP Semiconductors products are sold subject to the general terms and conditions of commercial sale, as published at [www.nxp.com](#), unless otherwise agreed in a valid written individual agreement. In case an individual agreement is concluded only the terms and conditions of the respective agreement shall apply. NXP Semiconductors hereby expressly objects to applying the customer's general terms and conditions with regard to the purchase of NXP Semiconductors products by customer.

No offer to sell or license — Nothing in this document may be interpreted or construed as an offer to sell products that is open for acceptance or the grant, conveyance or implication of any license under any copyrights, patents or other industrial or intellectual property rights.

Export control — This document as well as the item(s) described herein may be subject to export control regulations. Export might require a prior authorization from national authorities.

14.4 Trademarks

Notice: All referenced brands, product names, service names and trademarks are the property of their respective owners.