

HEF4017B

5-stage Johnson decade counter

Rev. 06 — 5 November 2009

Product data sheet

1. General description

The HEF4017B is a 5-stage Johnson decade counter with ten spike-free decoded active HIGH outputs (Q0 to Q9), an active LOW carry output from the most significant flip-flop ($\overline{Q}5-9$), active HIGH and active LOW clock inputs (CP0, $\overline{CP}1$) and an overriding asynchronous master reset input (MR).

The counter is advanced by either a LOW-to-HIGH transition at CP0 while $\overline{CP}1$ is LOW or a HIGH-to-LOW transition at CP1 while CP0 is HIGH (see [Table 3](#)).

When cascading counters, the $\overline{Q}5-9$ output, which is LOW while the counter is in states 5, 6, 7, 8, and 9, can be used to drive the CP0 input of the next counter. A HIGH on MR resets the counter to zero (Q0 = $\overline{Q}5-9$ = HIGH; Q1 to Q9 = LOW) independent of the clock inputs (CP0, $\overline{CP}1$).

Automatic counter code correction is provided by an internal circuit: following any illegal code the counter returns to a proper counting mode within 11 clock pulses.

Schmitt trigger action makes the clock inputs highly tolerant of slower rise and fall times.

It operates over a recommended V_{DD} power supply range of 3 V to 15 V referenced to V_{SS} (usually ground). Unused inputs must be connected to V_{DD} , V_{SS} , or another input. It is also suitable for use over both the industrial ($-40\text{ }^{\circ}\text{C}$ to $+85\text{ }^{\circ}\text{C}$) and automotive ($-40\text{ }^{\circ}\text{C}$ to $+125\text{ }^{\circ}\text{C}$) temperature ranges.

2. Features

- Automatic counter correction
- Tolerant of slow clock rise and fall times
- Fully static operation
- 5 V, 10 V, and 15 V parametric ratings
- Standardized symmetrical output characteristics
- Operates across the automotive temperature range $-40\text{ }^{\circ}\text{C}$ to $+125\text{ }^{\circ}\text{C}$
- Complies with JEDEC standard JESD 13-B

3. Applications

- Industrial and automotive

勝特力材料 886-3-5753170
勝特力电子(上海) 86-21-34970699
勝特力电子(深圳) 86-755-83298787
[Http://www.100y.com.tw](http://www.100y.com.tw)

4. Ordering information

Table 1. Ordering information

All types operate from -40°C to $+125^{\circ}\text{C}$

Type number	Package		Version
	Name	Description	
HEF4017BP	DIP16	plastic dual in-line package; 16 leads (300 mil)	SOT38-4
HEF4017BT	SO16	plastic small outline package; 16 leads; body width 3.9 mm	SOT109-1

5. Functional diagram

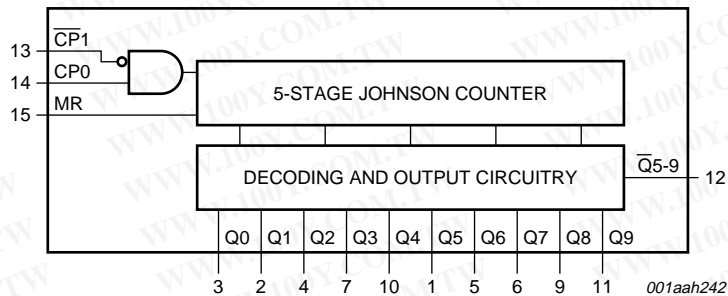

Fig 1. Functional diagram

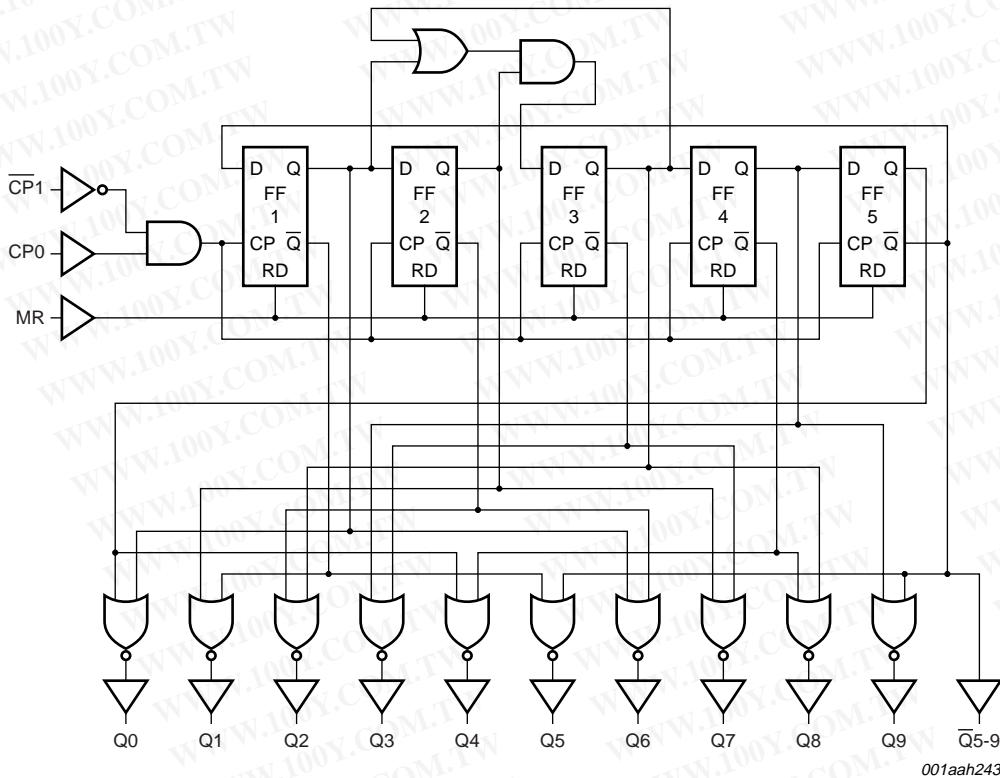
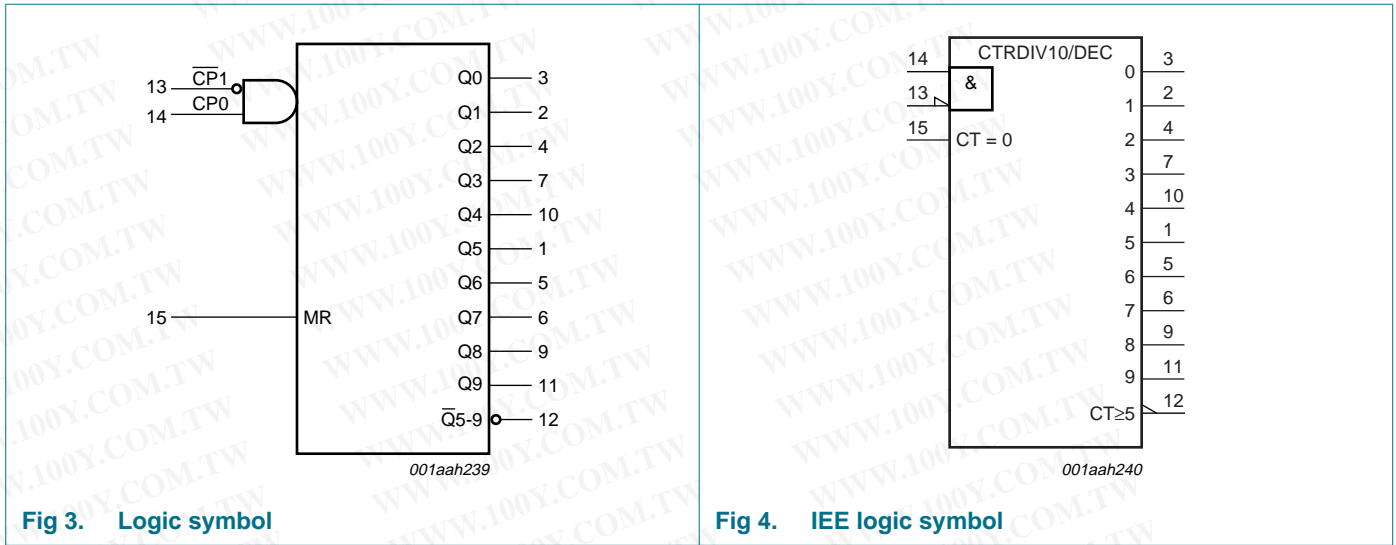
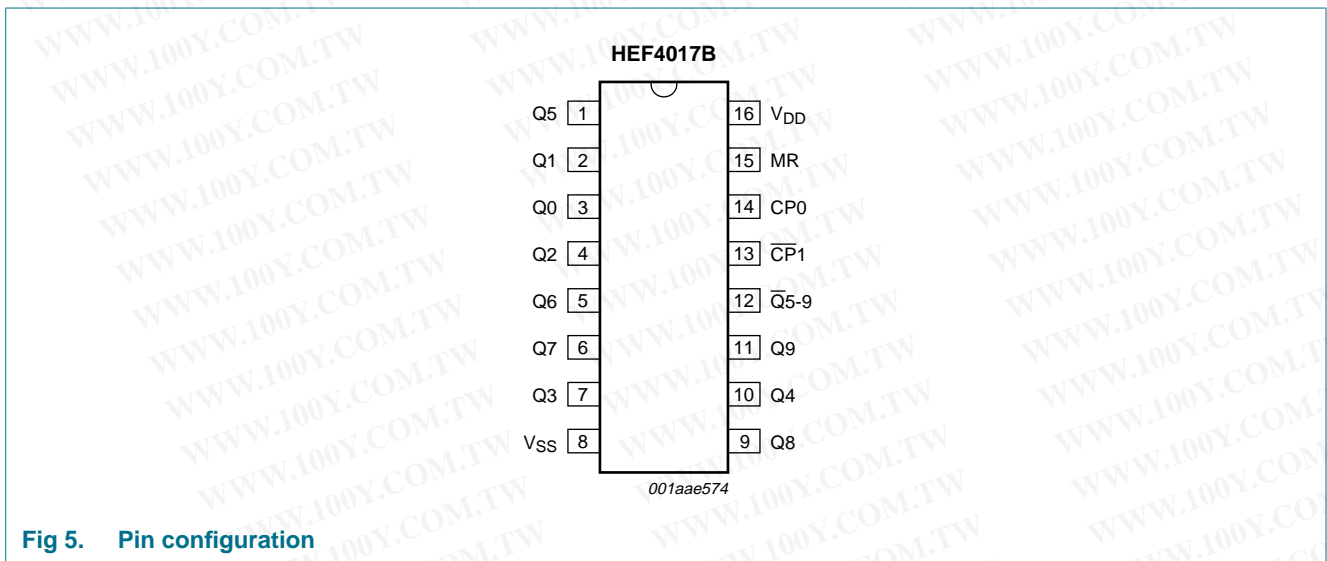

Fig 2. Logic diagram



6. Pinning information

6.1 Pinning



6.2 Pin description

Table 2. Pin description

Symbol	Pin	Description
Q0 to Q9	3, 2, 4, 7, 10, 1, 5, 6, 9, 11	decoded output
V _{SS}	8	ground supply voltage
$\bar{Q}5-9$	12	carry output (active LOW)
$\bar{CP}1$	13	clock input (HIGH-to-LOW edge-triggered)

Table 2. Pin description ...continued

Symbol	Pin	Description
CP0	14	clock input (LOW-to-HIGH edge-triggered)
MR	15	master reset input
V _{DD}	16	supply voltage

7. Functional description

Table 3. Function table [1]

MR	CP0	CP1	Operation
H	X	X	$Q0 = \bar{Q}5-9 = H$; Q1 to Q9 = L
L	H	↓	counter advances
L	↑	L	counter advances
L	L	X	no change
L	X	H	no change
L	H	↑	no change
L	↓	L	no change

[1] H = HIGH voltage level; L = LOW voltage level; X = don't care;
 ↑ = positive-going transition; ↓ = negative-going transition.

勝特力材料 886-3-5753170
 勝特力电子(上海) 86-21-34970699
 勝特力电子(深圳) 86-755-83298787
[Http://www.100y.com.tw](http://www.100y.com.tw)

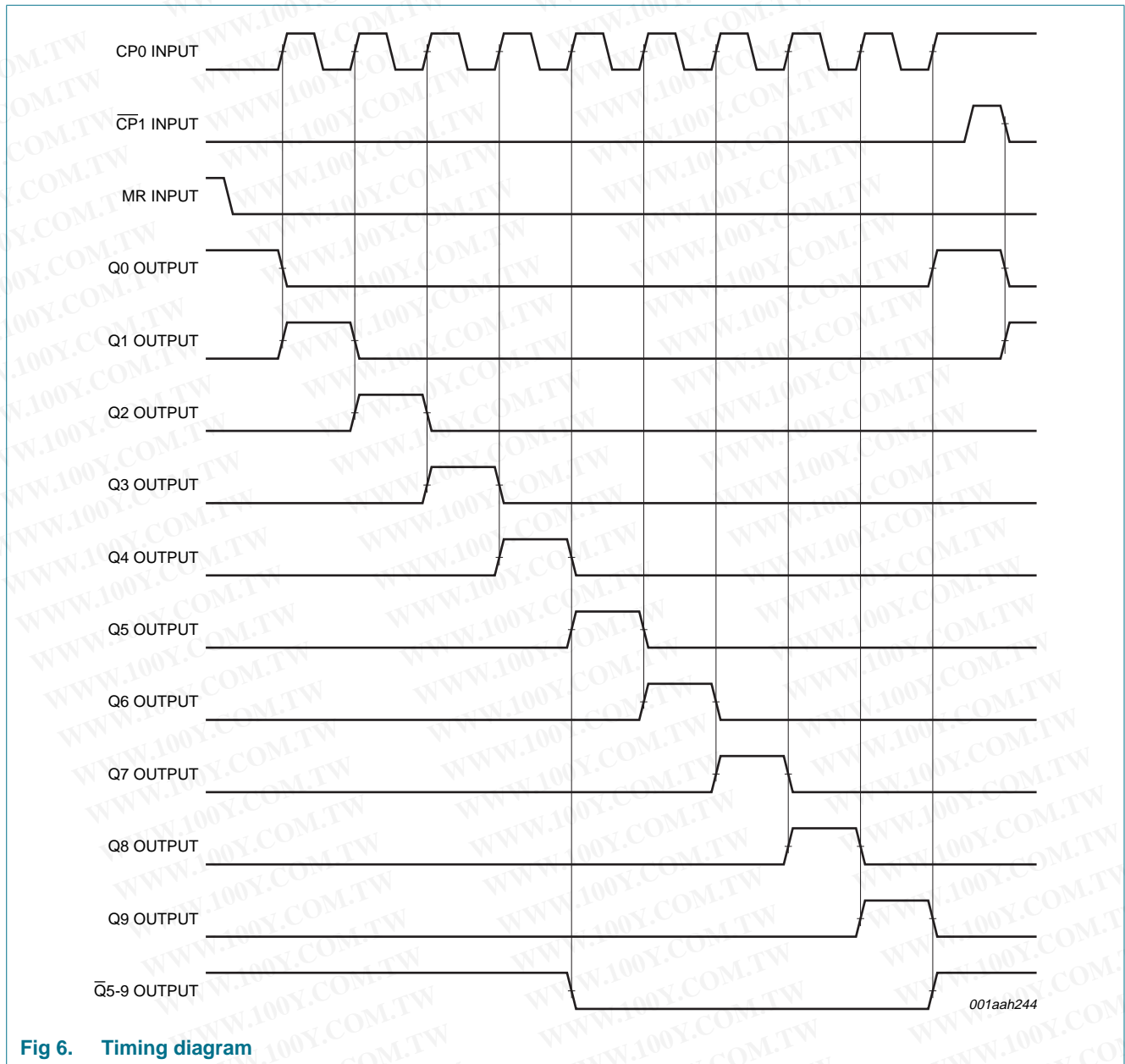

Fig 6. Timing diagram

8. Limiting values

Table 4. Limiting values

In accordance with the Absolute Maximum Rating System (IEC 60134).

Symbol	Parameter	Conditions	Min	Max	Unit
V_{DD}	supply voltage		-0.5	+18	V
I_{IK}	input clamping current	$V_I < -0.5 \text{ V}$ or $V_I > V_{DD} + 0.5 \text{ V}$	-	± 10	mA
V_I	input voltage		-0.5	$V_{DD} + 0.5$	V
I_{OK}	output clamping current	$V_O < -0.5 \text{ V}$ or $V_O > V_{DD} + 0.5 \text{ V}$	-	± 10	mA
$I_{I/O}$	input/output current		-	± 10	mA

Table 4. Limiting values ...continued

In accordance with the Absolute Maximum Rating System (IEC 60134).

Symbol	Parameter	Conditions	Min	Max	Unit	
I_{DD}	supply current		-	50	mA	
T_{stg}	storage temperature		-65	+150	°C	
T_{amb}	ambient temperature		-40	+125	°C	
P_{tot}	total power dissipation	$T_{amb} = -40\text{ °C to }+125\text{ °C}$				
		DIP16 package	[1]	-	750	mW
		SO16 package	[2]	-	500	mW
P	power dissipation	per output	-	100	mW	

[1] For DIP16 package: P_{tot} derates linearly with 12 mW/K above 70 °C.

[2] For SO16 package: P_{tot} derates linearly with 8 mW/K above 70 °C.

9. Recommended operating conditions

Table 5. Recommended operating conditions

Symbol	Parameter	Conditions	Min	Typ	Max	Unit
V_{DD}	supply voltage		3	-	15	V
V_I	input voltage		0	-	V_{DD}	V
T_{amb}	ambient temperature	in free air	-40	-	+125	°C
$\Delta t/\Delta V$	input transition rise and fall rate	$V_{DD} = 5\text{ V}$	-	-	3.75	µs/V
		$V_{DD} = 10\text{ V}$	-	-	0.5	µs/V
		$V_{DD} = 15\text{ V}$	-	-	0.08	µs/V

10. Static characteristics

Table 6. Static characteristics

$V_{SS} = 0\text{ V}$; $V_I = V_{SS}$ or V_{DD} unless otherwise specified.

Symbol	Parameter	Conditions	V_{DD}	$T_{amb} = -40\text{ °C}$		$T_{amb} = 25\text{ °C}$		$T_{amb} = 85\text{ °C}$		$T_{amb} = 125\text{ °C}$		Unit
				Min	Max	Min	Max	Min	Max	Min	Max	
V_{IH}	HIGH-level input voltage	$ I_O < 1\text{ }\mu\text{A}$	5 V	3.5	-	3.5	-	3.5	-	3.5	-	V
			10 V	7.0	-	7.0	-	7.0	-	7.0	-	V
			15 V	11.0	-	11.0	-	11.0	-	11.0	-	V
V_{IL}	LOW-level input voltage	$ I_O < 1\text{ }\mu\text{A}$	5 V	-	1.5	-	1.5	-	1.5	-	1.5	V
			10 V	-	3.0	-	3.0	-	3.0	-	3.0	V
			15 V	-	4.0	-	4.0	-	4.0	-	4.0	V
V_{OH}	HIGH-level output voltage	$ I_O < 1\text{ }\mu\text{A}$; $V_I = V_{SS}$ or V_{DD}	5 V	4.95	-	4.95	-	4.95	-	4.95	-	V
			10 V	9.95	-	9.95	-	9.95	-	9.95	-	V
			15 V	14.95	-	14.95	-	14.95	-	14.95	-	V
V_{OL}	LOW-level output voltage	$ I_O < 1\text{ }\mu\text{A}$; $V_I = V_{SS}$ or V_{DD}	5 V	-	0.05	-	0.05	-	0.05	-	0.05	V
			10 V	-	0.05	-	0.05	-	0.05	-	0.05	V
			15 V	-	0.05	-	0.05	-	0.05	-	0.05	V

Table 6. Static characteristics ...continued
 $V_{SS} = 0\text{ V}$; $V_I = V_{SS}$ or V_{DD} unless otherwise specified.

Symbol	Parameter	Conditions	V_{DD}	$T_{amb} = -40\text{ }^\circ\text{C}$		$T_{amb} = 25\text{ }^\circ\text{C}$		$T_{amb} = 85\text{ }^\circ\text{C}$		$T_{amb} = 125\text{ }^\circ\text{C}$		Unit
				Min	Max	Min	Max	Min	Max	Min	Max	
I_{OH}	HIGH-level output current	$V_O = 2.5\text{ V}$	5 V	-1.7	-	-1.4	-	-1.1	-	-1.1	-	mA
		$V_O = 4.6\text{ V}$	5 V	-0.64	-	-0.5	-	-0.36	-	-0.36	-	mA
		$V_O = 9.5\text{ V}$	10 V	-1.6	-	-1.3	-	-0.9	-	-0.9	-	mA
		$V_O = 13.5\text{ V}$	15 V	-4.2	-	-3.4	-	-2.4	-	-2.4	-	mA
I_{OL}	LOW-level output current	$V_O = 0.4\text{ V}$	5 V	0.64	-	0.5	-	0.36	-	0.36	-	mA
		$V_O = 0.5\text{ V}$	10 V	1.6	-	1.3	-	0.9	-	0.9	-	mA
		$V_O = 1.5\text{ V}$	15 V	4.2	-	3.4	-	2.4	-	2.4	-	mA
I_I	input leakage current		15 V	-	± 0.1	-	± 0.1	-	± 1.0	-	± 1.0	μA
I_{DD}	supply current	$I_O = 0\text{ A}$;	5 V	-	5	-	5	-	150	-	150	μA
		$V_I = V_{SS}$ or V_{DD}	10 V	-	10	-	10	-	300	-	300	μA
			15 V	-	20	-	20	-	600	-	600	μA
C_I	input capacitance		-	-	-	7.5	-	-	-	-	pF	

11. Dynamic characteristics

Table 7. Dynamic characteristics
 $T_{amb} = 25\text{ }^\circ\text{C}$; $V_{SS} = 0\text{ V}$; for test circuit see [Figure 10](#)

Symbol	Parameter	Conditions	V_{DD}	Extrapolation formula ^[1]	Min	Typ	Max	Unit
t_{PHL}	HIGH to LOW propagation delay	CP0, $\overline{CP1} \rightarrow Q0$ to $Q9$; see Figure 7	5 V	$113\text{ ns} + (0.55\text{ ns/pF}) C_L$	-	140	280	ns
			10 V	$44\text{ ns} + (0.23\text{ ns/pF}) C_L$	-	55	110	ns
			15 V	$32\text{ ns} + (0.16\text{ ns/pF}) C_L$	-	40	80	ns
		CP0, $\overline{CP1} \rightarrow Q5-9$; see Figure 7	5 V	$118\text{ ns} + (0.55\text{ ns/pF}) C_L$	-	145	290	ns
			10 V	$44\text{ ns} + (0.23\text{ ns/pF}) C_L$	-	55	110	ns
			15 V	$32\text{ ns} + (0.16\text{ ns/pF}) C_L$	-	40	80	ns
		MR $\rightarrow Q1$ to $Q9$; see Figure 8	5 V	$88\text{ ns} + (0.55\text{ ns/pF}) C_L$	-	115	230	ns
			10 V	$39\text{ ns} + (0.23\text{ ns/pF}) C_L$	-	50	100	ns
			15 V	$27\text{ ns} + (0.16\text{ ns/pF}) C_L$	-	35	70	ns

勝特力材料 886-3-5753170
 勝特力电子(上海) 86-21-34970699
 勝特力电子(深圳) 86-755-83298787
[Http://www.100y.com.tw](http://www.100y.com.tw)

Table 7. Dynamic characteristics ...continued
 $T_{amb} = 25\text{ }^{\circ}\text{C}$; $V_{SS} = 0\text{ V}$; for test circuit see [Figure 10](#)

Symbol	Parameter	Conditions	V_{DD}	Extrapolation formula ^[1]	Min	Typ	Max	Unit
t_{PLH}	LOW to HIGH propagation delay	CP0, $\overline{\text{CP1}} \rightarrow \text{Q0 to Q9}$; see Figure 7	5 V	$98\text{ ns} + (0.55\text{ ns/pF}) C_L$	-	125	250	ns
			10 V	$39\text{ ns} + (0.23\text{ ns/pF}) C_L$	-	50	100	ns
			15 V	$32\text{ ns} + (0.16\text{ ns/pF}) C_L$	-	40	80	ns
		CP0, $\overline{\text{CP1}} \rightarrow \overline{\text{Q5-9}}$; see Figure 7	5 V	$98\text{ ns} + (0.55\text{ ns/pF}) C_L$	-	125	250	ns
			10 V	$39\text{ ns} + (0.23\text{ ns/pF}) C_L$	-	50	100	ns
			15 V	$32\text{ ns} + (0.16\text{ ns/pF}) C_L$	-	40	80	ns
		MR $\rightarrow \overline{\text{Q5-9}}$; see Figure 8	5 V	$83\text{ ns} + (0.55\text{ ns/pF}) C_L$	-	110	220	ns
			10 V	$34\text{ ns} + (0.23\text{ ns/pF}) C_L$	-	45	90	ns
			15 V	$27\text{ ns} + (0.16\text{ ns/pF}) C_L$	-	35	70	ns
		MR $\rightarrow \text{Q0}$; see Figure 8	5 V	$103\text{ ns} + (0.55\text{ ns/pF}) C_L$	-	130	260	ns
			10 V	$44\text{ ns} + (0.23\text{ ns/pF}) C_L$	-	55	105	ns
			15 V	$32\text{ ns} + (0.16\text{ ns/pF}) C_L$	-	40	75	ns
t_t	transition time	see Figure 7	5 V ^[2]	$10\text{ ns} + (1.00\text{ ns/pF}) C_L$	-	60	120	ns
			10 V	$9\text{ ns} + (0.42\text{ ns/pF}) C_L$	-	30	60	ns
			15 V	$6\text{ ns} + (0.28\text{ ns/pF}) C_L$	-	20	40	ns
t_h	hold time	CP0 $\rightarrow \overline{\text{CP1}}$; see Figure 9	5 V		90	45	-	ns
			10 V		40	20	-	ns
			15 V		20	10	-	ns
		$\overline{\text{CP1}} \rightarrow \text{CP0}$; see Figure 9	5 V		80	40	-	ns
			10 V		40	20	-	ns
			15 V		30	10	-	ns
t_w	pulse width	CP0 input LOW; minimum width; see Figure 8	5 V		80	40	-	ns
			10 V		40	20	-	ns
			15 V		30	15	-	ns
		$\overline{\text{CP1}}$ input HIGH; minimum width; see Figure 8	5 V		80	40	-	ns
			10 V		40	20	-	ns
			15 V		30	15	-	ns
		MR input HIGH; minimum width; see Figure 8	5 V		50	25	-	ns
			10 V		30	15	-	ns
			15 V		20	10	-	ns
t_{rec}	recovery time	MR input; see Figure 8	5 V		60	30	-	ns
			10 V		30	15	-	ns
			15 V		20	10	-	ns
f_{max}	maximum frequency	see Figure 8	5 V		6	12	-	MHz
			10 V		12	30	-	MHz
			15 V		15	30	-	MHz

[1] The typical values of the propagation delay and transition times are calculated from the extrapolation formulas shown (C_L in pF).

[2] t_t is the same as t_{THL} and t_{TLH} .

Table 8. Dynamic power dissipation P_D

P_D can be calculated from the formulas shown. $V_{SS} = 0\text{ V}$; $t_r = t_f \leq 20\text{ ns}$; $T_{amb} = 25\text{ }^\circ\text{C}$.

Symbol	Parameter	V_{DD}	Typical formula for P_D (μW)	where:
P_D	dynamic power dissipation	5 V	$P_D = 500 \times f_i + \Sigma(f_o \times C_L) \times V_{DD}^2$	f_i = input frequency in MHz;
		10 V	$P_D = 2200 \times f_i + \Sigma(f_o \times C_L) \times V_{DD}^2$	f_o = output frequency in MHz;
		15 V	$P_D = 6000 \times f_i + \Sigma(f_o \times C_L) \times V_{DD}^2$	C_L = output load capacitance in pF;
				V_{DD} = supply voltage in V;
				$\Sigma(C_L \times f_o)$ = sum of the outputs.

12. Waveforms

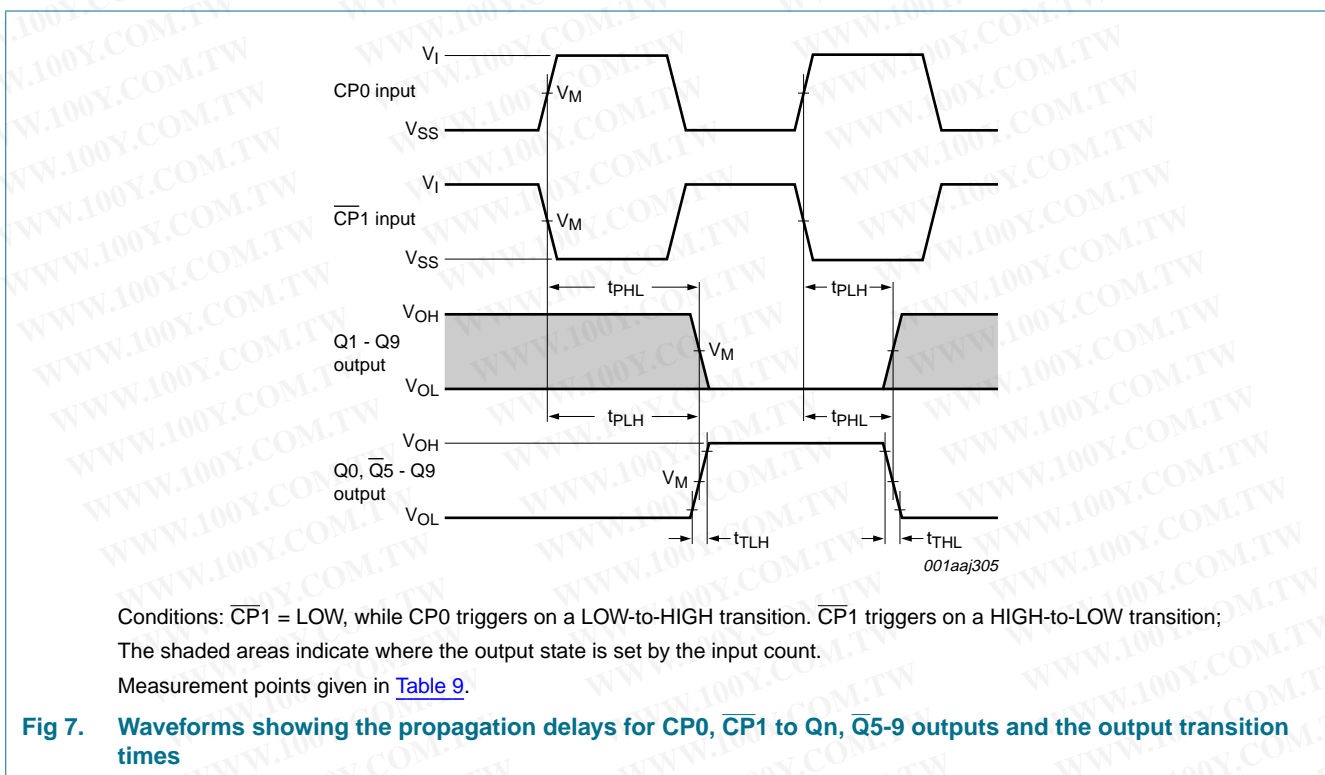

勝特力材料 886-3-5753170
 勝特力电子(上海) 86-21-34970699
 勝特力电子(深圳) 86-755-83298787
[Http://www.100y.com.tw](http://www.100y.com.tw)

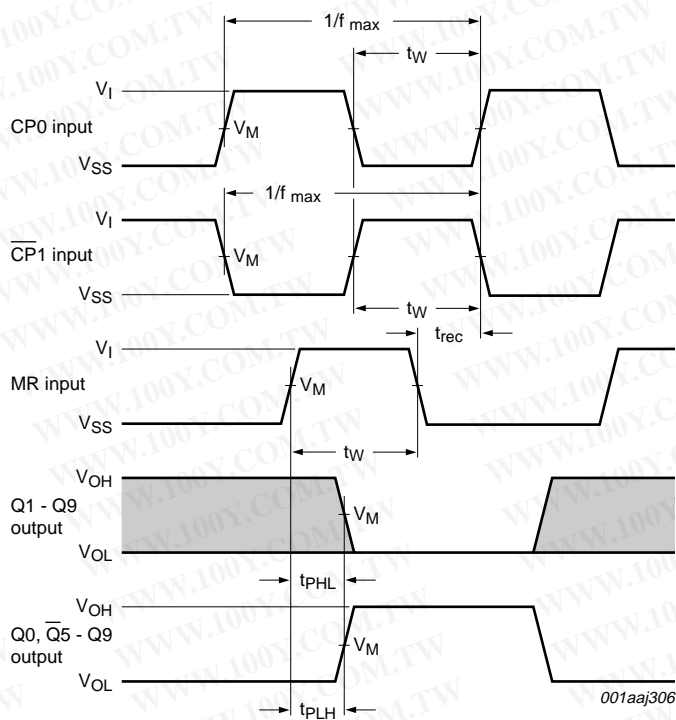

Conditions: $\overline{CP1} = \text{LOW}$, while CP0 triggers on a LOW-to-HIGH transition, t_w and t_{rec} are measured when CP0 = HIGH and $\overline{CP1}$ triggers on a HIGH-to-LOW transition.

The shaded areas indicate where the output state is set by the input count.

Measurement points given in [Table 9](#).

Fig 8. Waveforms showing the minimum pulse width for CP0, $\overline{CP1}$ and MR input; the maximum frequency for CP0 and CP1 input; the recovery time for MR and the MR input to Qn and Q5-9 output propagation delays

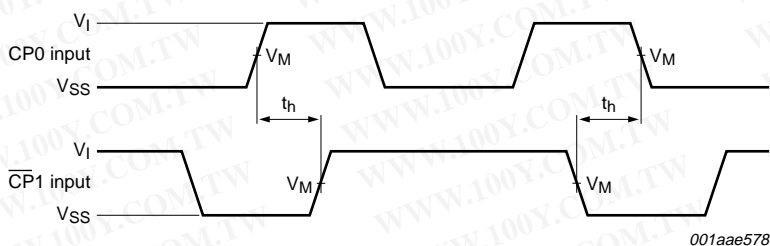

Hold times are shown as positive values, but may be specified as negative values;

Measurement points given in [Table 9](#).

Fig 9. Waveforms showing hold times for CP0 to $\overline{CP1}$ and $\overline{CP1}$ to CP0

Table 9. Measurement points

Supply voltage	Input	Output
V _{DD}	V _M	V _M
5 V to 15 V	0.5V _{DD}	0.5V _{DD}

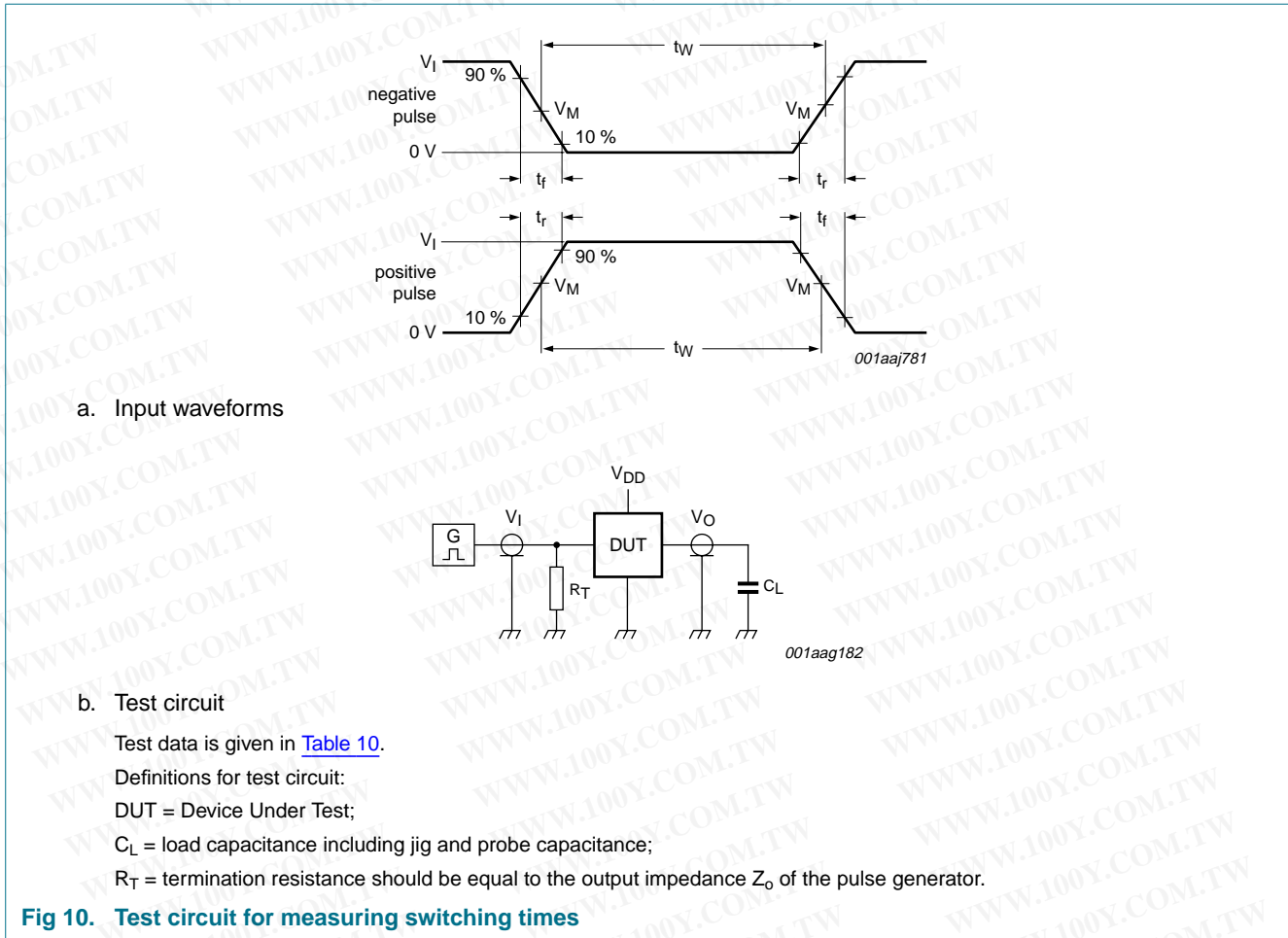

Table 10. Test data

Supply voltage	Input	Load
V_{DD} 5 V to 15 V	V_I V_{SS} or V_{DD}	t_r, t_f ≤ 20 ns
		C_L 50 pF

13. Application information

Some examples of applications for the HEF4017B are:

- Decade counter with decimal decoding
- 1 out of n decoding counter (when cascaded)
- Sequential controller
- Timer

[Figure 11](#) shows a technique for extending the number of decoded output states for the HEF4017B. Decoded outputs are sequential within each stage and from stage to stage, with no dead time (except propagation delay).

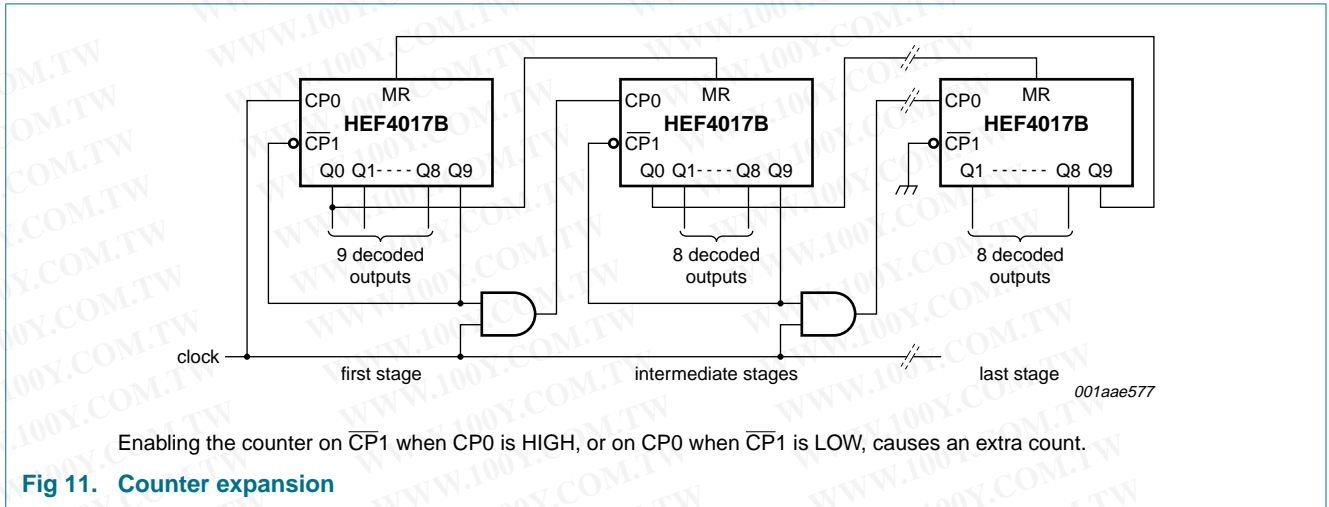

勝特力材料 886-3-5753170
 勝特力电子(上海) 86-21-34970699
 勝特力电子(深圳) 86-755-83298787
[Http://www.100y.com.tw](http://www.100y.com.tw)

14. Package outline

DIP16: plastic dual in-line package; 16 leads (300 mil)

SOT38-4

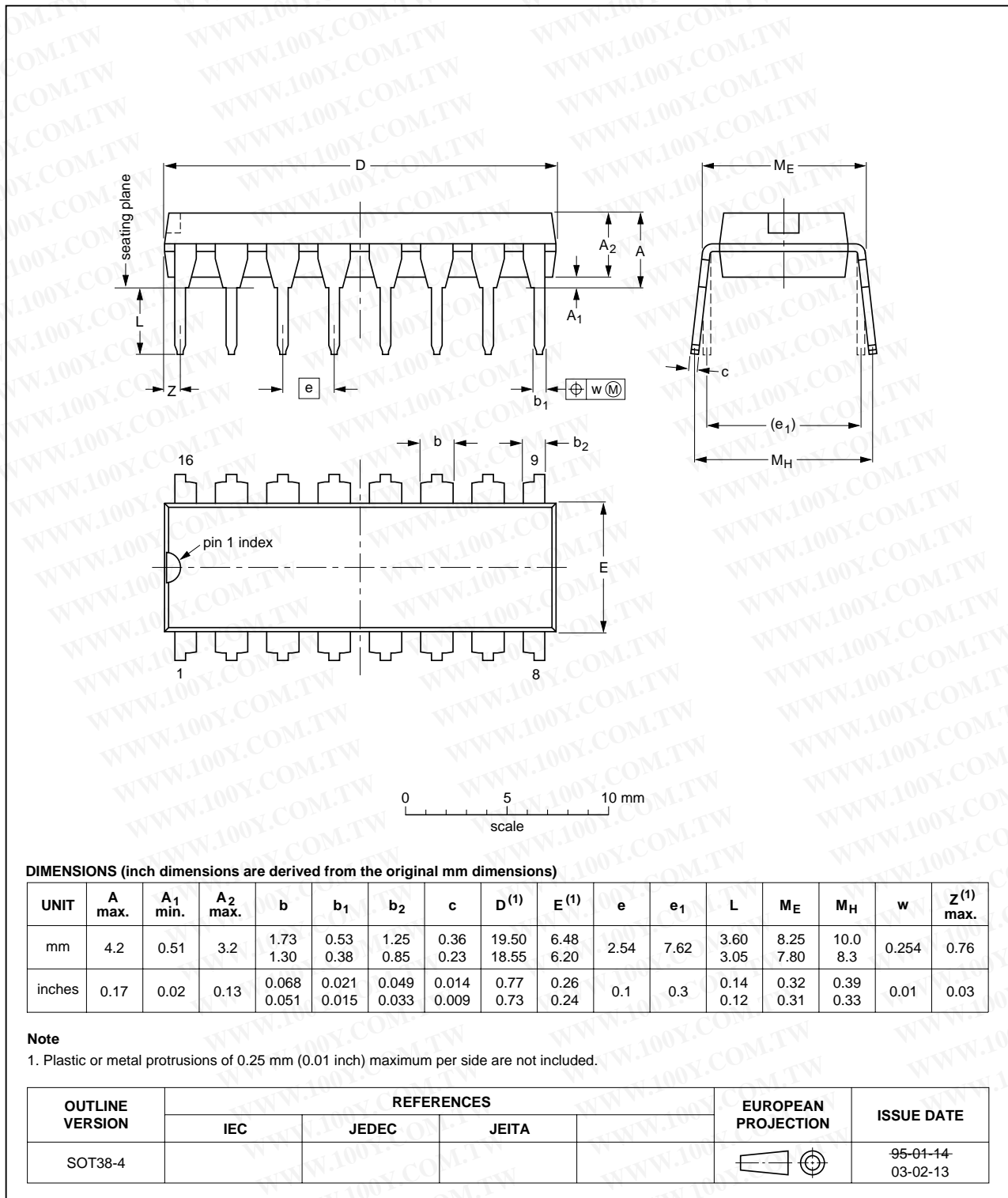

Fig 12. Package outline SOT38-4 (DIP16)

SO16: plastic small outline package; 16 leads; body width 3.9 mm

SOT109-1

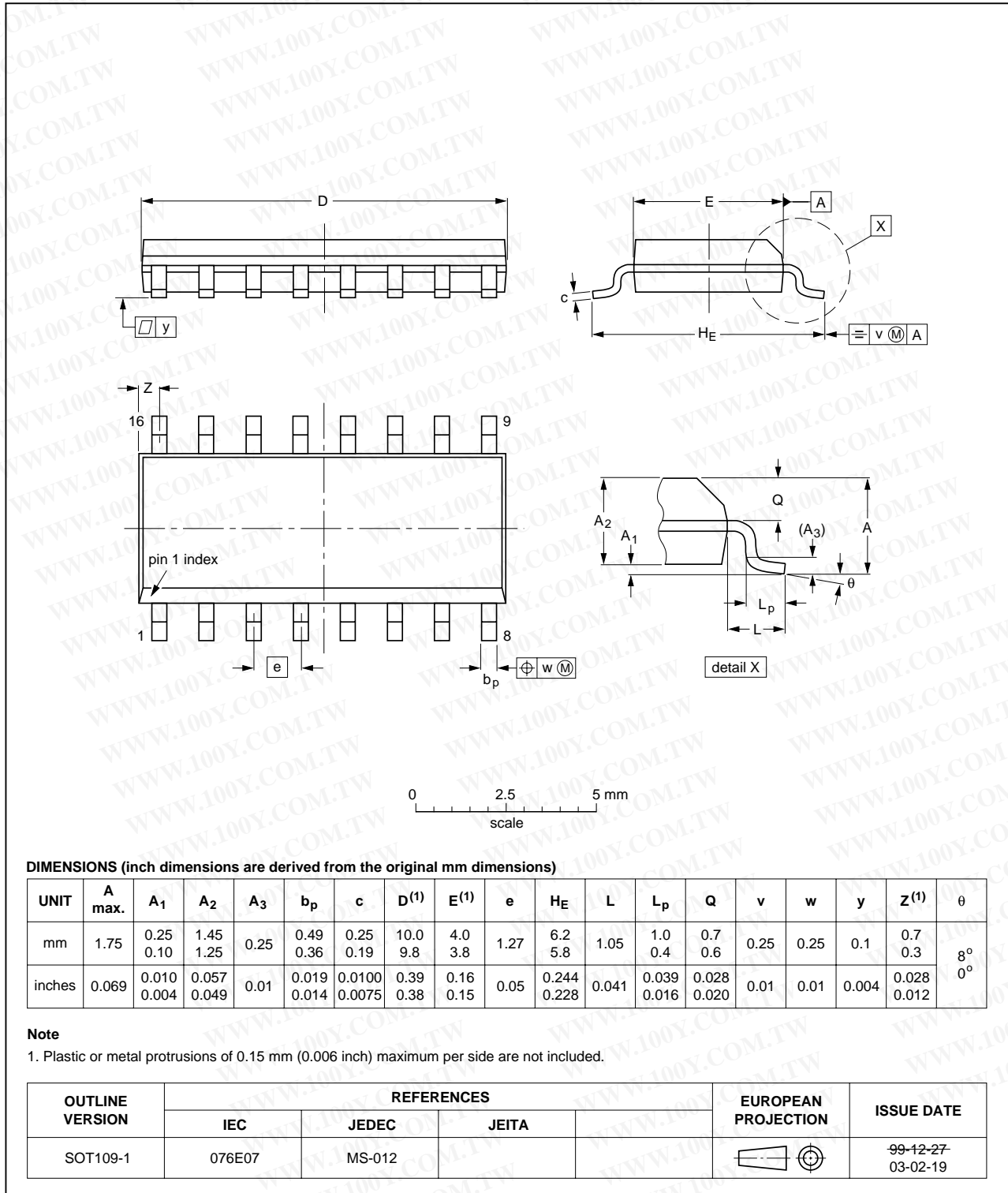

Fig 13. Package outline SOT109-1 (SO16)

15. Revision history

Table 11. Revision history

Document ID	Release date	Data sheet status	Change notice	Supersedes
HEF4017B_6	20091105	Product data sheet	-	HEF4017B_5
Modifications:	<ul style="list-style-type: none"> • Section 9 "Recommended operating conditions" $\Delta t/\Delta V$ values updated. 			
HEF4017B_5	20090709	Product data sheet	-	HEF4017B_4
HEF4017B_4	20081209	Product data sheet	-	HEF4017B_CNV_3
HEF4017B_CNV_3	19950101	Product specification	-	HEF4017B_CNV_2
HEF4017B_CNV_2	19950101	Product specification	-	-

勝特力材料 886-3-5753170
 勝特力电子(上海) 86-21-34970699
 勝特力电子(深圳) 86-755-83298787
[Http://www.100y.com.tw](http://www.100y.com.tw)

16. Legal information

16.1 Data sheet status

Document status ^{[1][2]}	Product status ^[3]	Definition
Objective [short] data sheet	Development	This document contains data from the objective specification for product development.
Preliminary [short] data sheet	Qualification	This document contains data from the preliminary specification.
Product [short] data sheet	Production	This document contains the product specification.

[1] Please consult the most recently issued document before initiating or completing a design.

[2] The term 'short data sheet' is explained in section "Definitions".

[3] The product status of device(s) described in this document may have changed since this document was published and may differ in case of multiple devices. The latest product status information is available on the Internet at URL [_____](#)

16.2 Definitions

Draft — The document is a draft version only. The content is still under internal review and subject to formal approval, which may result in modifications or additions. NXP Semiconductors does not give any representations or warranties as to the accuracy or completeness of information included herein and shall have no liability for the consequences of use of such information.

Short data sheet — A short data sheet is an extract from a full data sheet with the same product type number(s) and title. A short data sheet is intended for quick reference only and should not be relied upon to contain detailed and full information. For detailed and full information see the relevant full data sheet, which is available on request via the local NXP Semiconductors sales office. In case of any inconsistency or conflict with the short data sheet, the full data sheet shall prevail.

16.3 Disclaimers

General — Information in this document is believed to be accurate and reliable. However, NXP Semiconductors does not give any representations or warranties, expressed or implied, as to the accuracy or completeness of such information and shall have no liability for the consequences of use of such information.

Right to make changes — NXP Semiconductors reserves the right to make changes to information published in this document, including without limitation specifications and product descriptions, at any time and without notice. This document supersedes and replaces all information supplied prior to the publication hereof.

Suitability for use — NXP Semiconductors products are not designed, authorized or warranted to be suitable for use in medical, military, aircraft, space or life support equipment, nor in applications where failure or malfunction of an NXP Semiconductors product can reasonably be expected to result in personal injury, death or severe property or environmental

damage. NXP Semiconductors accepts no liability for inclusion and/or use of NXP Semiconductors products in such equipment or applications and therefore such inclusion and/or use is at the customer's own risk.

Applications — Applications that are described herein for any of these products are for illustrative purposes only. NXP Semiconductors makes no representation or warranty that such applications will be suitable for the specified use without further testing or modification.

Limiting values — Stress above one or more limiting values (as defined in the Absolute Maximum Ratings System of IEC 60134) may cause permanent damage to the device. Limiting values are stress ratings only and operation of the device at these or any other conditions above those given in the Characteristics sections of this document is not implied. Exposure to limiting values for extended periods may affect device reliability.

Terms and conditions of sale — NXP Semiconductors products are sold subject to the general terms and conditions of commercial sale, as published at, including those pertaining to warranty, intellectual property rights infringement and limitation of liability, unless explicitly otherwise agreed to in writing by NXP Semiconductors. In case of any inconsistency or conflict between information in this document and such terms and conditions, the latter will prevail.

No offer to sell or license — Nothing in this document may be interpreted or construed as an offer to sell products that is open for acceptance or the grant, conveyance or implication of any license under any copyrights, patents or other industrial or intellectual property rights.

Export control — This document as well as the item(s) described herein may be subject to export control regulations. Export might require a prior authorization from national authorities.

16.4 Trademarks

Notice: All referenced brands, product names, service names and trademarks are the property of their respective owners.

17. Contact information

For more information, please visit: _____

For sales office addresses, please send an email to: _____

18. Contents

1 General description 1

2 Features 1

3 Applications 1

4 Ordering information 2

5 Functional diagram 2

6 Pinning information 3

6.1 Pinning 3

6.2 Pin description 3

7 Functional description 4

8 Limiting values 5

9 Recommended operating conditions 6

10 Static characteristics 6

11 Dynamic characteristics 7

12 Waveforms 9

13 Application information 11

14 Package outline 13

15 Revision history 15

16 Legal information 16

16.1 Data sheet status 16

16.2 Definitions 16

16.3 Disclaimers 16

16.4 Trademarks 16

17 Contact information 16

18 Contents 17

勝特力材料 886-3-5753170
 勝特力电子(上海) 86-21-34970699
 勝特力电子(深圳) 86-755-83298787
[Http://www.100y.com.tw](http://www.100y.com.tw)



Please be aware that important notices concerning this document and the product(s) described herein, have been included in section 'Legal information'.