

74HC4052; 74HCT4052

Dual 4-channel analog multiplexer/demultiplexer

Rev. 10 — 19 July 2012

Product data sheet

1. General description

The 74HC4052; 74HCT4052 is a high-speed Si-gate CMOS device and is pin compatible with the HEF4052B. The device is specified in compliance with JEDEC standard no. 7A.

The 74HC4052; 74HCT4052 is a dual 4-channel analog multiplexer/demultiplexer with common select logic. Each multiplexer has four independent inputs/outputs (pins nY0 to nY3) and a common input/output (pin nZ). The common channel select logics include two digital select inputs (pins S0 and S1) and an active LOW enable input (pin \bar{E}). When pin \bar{E} = LOW, one of the four switches is selected (low-impedance ON-state) with pins S0 and S1. When pin \bar{E} = HIGH, all switches are in the high-impedance OFF-state, independent of pins S0 and S1.

V_{CC} and GND are the supply voltage pins for the digital control inputs (pins S0, S1 and \bar{E}). The V_{CC} to GND ranges are 2.0 V to 10.0 V for the 74HC4052 and 4.5 V to 5.5 V for the 74HCT4052. The analog inputs/outputs (pins nY0 to nY3 and nZ) can swing between V_{CC} as a positive limit and V_{EE} as a negative limit. $V_{CC} - V_{EE}$ may not exceed 10.0 V.

For operation as a digital multiplexer/demultiplexer, V_{EE} is connected to GND (typically ground).

2. Features and benefits

- Wide analog input voltage range from -5 V to +5 V
- Low ON resistance:
 - ◆ 80 Ω (typical) at $V_{CC} - V_{EE} = 4.5$ V
 - ◆ 70 Ω (typical) at $V_{CC} - V_{EE} = 6.0$ V
 - ◆ 60 Ω (typical) at $V_{CC} - V_{EE} = 9.0$ V
- Logic level translation: to enable 5 V logic to communicate with ± 5 V analog signals
- Typical 'break before make' built-in
- Complies with JEDEC standard no. 7A
- ESD protection:
 - ◆ HBM JESD22-A114F exceeds 2000 V
 - ◆ MM JESD22-A115-A exceeds 200 V
 - ◆ CDM JESD22-C101E exceeds 1000 V
- Specified from -40 °C to +85 °C and -40 °C to +125 °C

勝特力材料 886-3-5753170
勝特力电子(上海) 86-21-34970699
勝特力电子(深圳) 86-755-83298787
[Http://www.100y.com.tw](http://www.100y.com.tw)



3. Applications

- Analog multiplexing and demultiplexing
- Digital multiplexing and demultiplexing
- Signal gating

4. Ordering information

Table 1. Ordering information

Type number	Package			
	Temperature range	Name	Description	Version
74HC4052				
74HC4052N	-40 °C to +125 °C	DIP16	plastic dual in-line package; 16 leads (300 mil)	SOT38-4
74HC4052D	-40 °C to +125 °C	SO16	plastic small outline package; 16 leads; body width 3.9 mm	SOT109-1
74HC4052DB	-40 °C to +125 °C	SSOP16	plastic shrink small outline package; 16 leads; body width 5.3 mm	SOT338-1
74HC4052PW	-40 °C to +125 °C	TSSOP16	plastic thin shrink small outline package; 16 leads; body width 4.4 mm	SOT403-1
74HC4052BQ	-40 °C to +125 °C	DHVQFN16	plastic dual-in line compatible thermal enhanced very thin quad flat package; no leads; 16 terminals; body 2.5 × 3.5 × 0.85 mm	SOT763-1
74HCT4052				
74HCT4052N	-40 °C to +125 °C	DIP16	plastic dual in-line package; 16 leads (300 mil)	SOT38-4
74HCT4052D	-40 °C to +125 °C	SO16	plastic small outline package; 16 leads; body width 3.9 mm	SOT109-1
74HCT4052DB	-40 °C to +125 °C	SSOP16	plastic shrink small outline package; 16 leads; body width 5.3 mm	SOT338-1
74HCT4052PW	-40 °C to +125 °C	TSSOP16	plastic thin shrink small outline package; 16 leads; body width 4.4 mm	SOT403-1
74HCT4052BQ	-40 °C to +125 °C	DHVQFN16	plastic dual-in line compatible thermal enhanced very thin quad flat package; no leads; 16 terminals; body 2.5 × 3.5 × 0.85 mm	SOT763-1

勝特力材料 886-3-5753170
 勝特力电子(上海) 86-21-34970699
 勝特力电子(深圳) 86-755-83298787
[Http://www.100y.com.tw](http://www.100y.com.tw)

5. Functional diagram

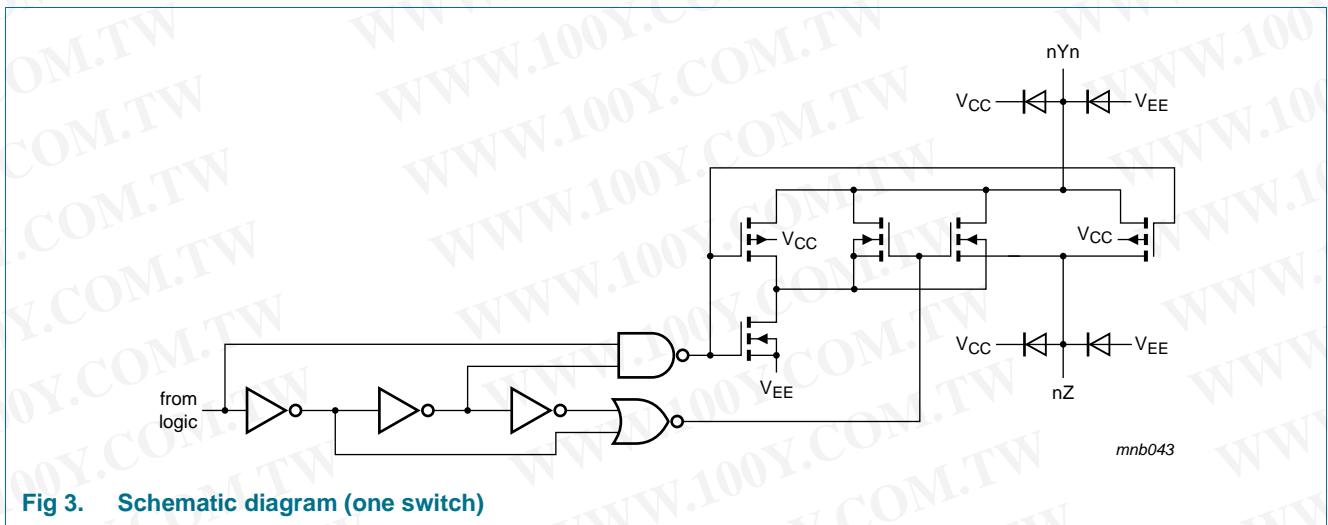
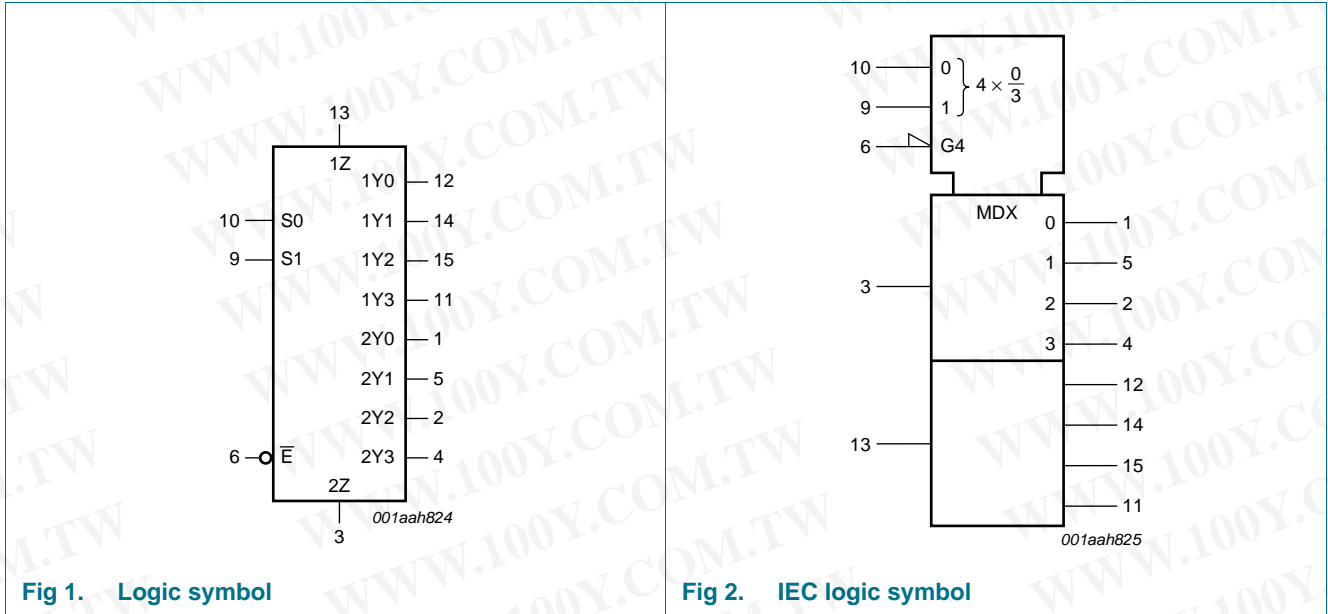

勝特力材料 886-3-5753170
 勝特力电子(上海) 86-21-34970699
 勝特力电子(深圳) 86-755-83298787
[Http://www.100y.com.tw](http://www.100y.com.tw)

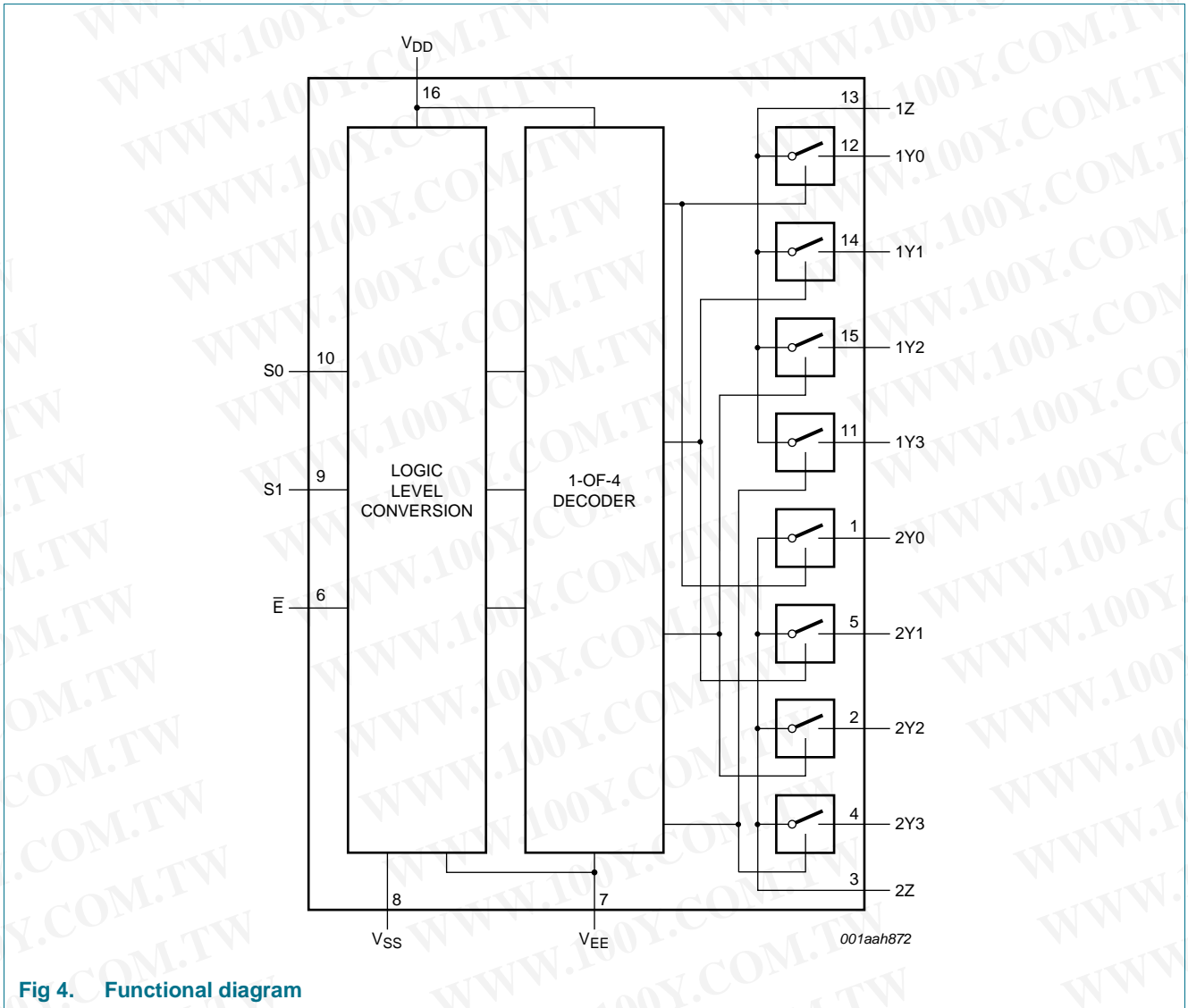

Fig 4. Functional diagram

勝特力材料 886-3-5753170
 勝特力电子(上海) 86-21-34970699
 勝特力电子(深圳) 86-755-83298787
[Http://www.100y.com.tw](http://www.100y.com.tw)

勝特力材料 886-3-5753170
 勝特力电子(上海) 86-21-34970699
 勝特力电子(深圳) 86-755-83298787
[Http://www.100y.com.tw](http://www.100y.com.tw)

6. Pinning information

6.1 Pinning

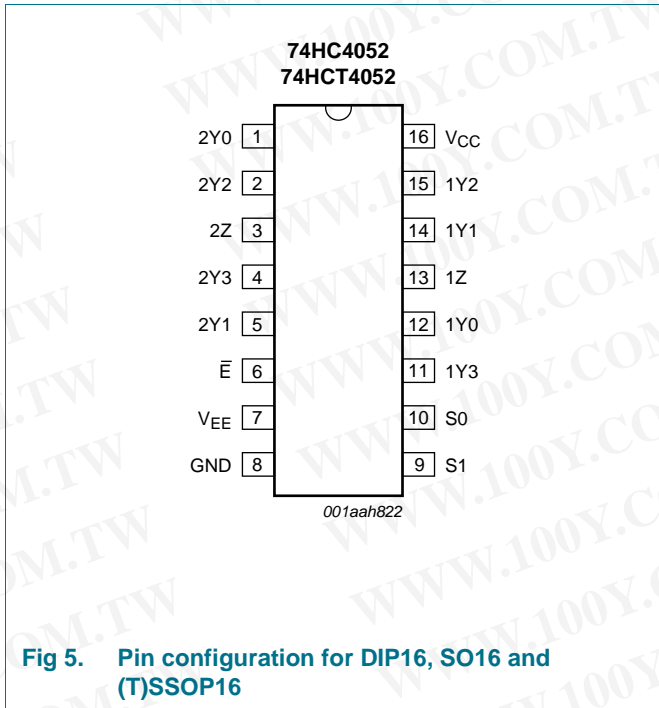

Fig 5. Pin configuration for DIP16, SO16 and (T)SSOP16

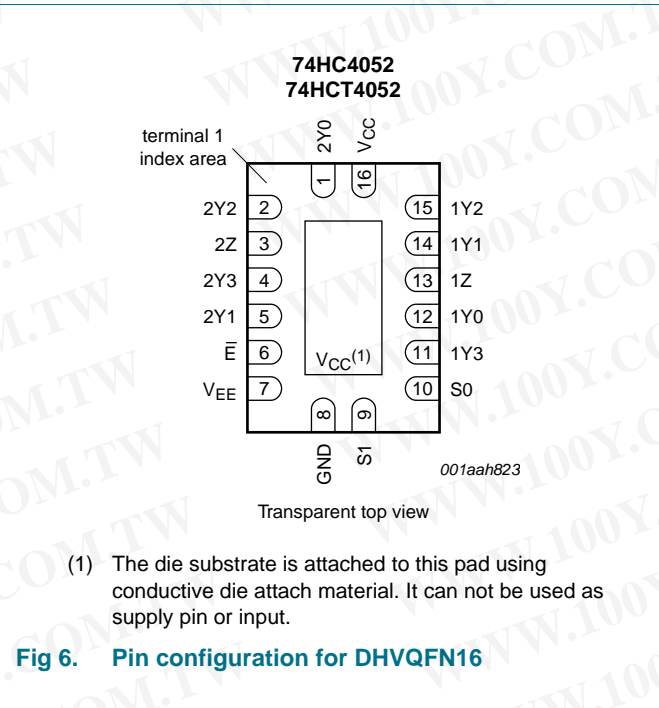

Fig 6. Pin configuration for DHVQFN16

6.2 Pin description

Table 2. Pin description

Symbol	Pin	Description
2Y0	1	independent input or output 2Y0
2Y2	2	independent input or output 2Y2
2Z	3	common input or output 2
2Y3	4	independent input or output 2Y3
2Y1	5	independent input or output 2Y1
\bar{E}	6	enable input (active LOW)
V_{EE}	7	negative supply voltage
GND	8	ground (0 V)
S1	9	select logic input 1
S0	10	select logic input 0
1Y3	11	independent input or output 1Y3
1Y0	12	independent input or output 1Y0
1Z	13	common input or output 1
1Y1	14	independent input or output 1Y1
1Y2	15	independent input or output 1Y2
V_{CC}	16	positive supply voltage

勝特力材料 886-3-5753170
 勝特力电子(上海) 86-21-34970699
 勝特力电子(深圳) 86-755-83298787
[Http://www.100y.com.tw](http://www.100y.com.tw)

7. Functional description

7.1 Function table

Table 3. Function table^[1]

Input			Channel on
\bar{E}	S1	S0	
L	L	L	nY0 and nZ
L	L	H	nY1 and nZ
L	H	L	nY2 and nZ
L	H	H	nY3 and nZ
H	X	X	none

- [1] H = HIGH voltage level;
 L = LOW voltage level;
 X = don't care.

8. Limiting values

Table 4. Limiting values

In accordance with the Absolute Maximum Rating System (IEC 60134).
 Voltages are referenced to $V_{EE} = \text{GND}$ (ground = 0 V).

Symbol	Parameter	Conditions	Min	Max	Unit
V_{CC}	supply voltage		^[1] -0.5	+11.0	V
I_{IK}	input clamping current	$V_I < -0.5 \text{ V}$ or $V_I > V_{CC} + 0.5 \text{ V}$	-	±20	mA
I_{SK}	switch clamping current	$V_{SW} < -0.5 \text{ V}$ or $V_{SW} > V_{CC} + 0.5 \text{ V}$	-	±20	mA
I_{SW}	switch current	$-0.5 \text{ V} < V_{SW} < V_{CC} + 0.5 \text{ V}$	-	±25	mA
I_{EE}	supply current		-	±20	mA
I_{CC}	supply current		-	50	mA
I_{GND}	ground current		-	-50	mA
T_{stg}	storage temperature		-65	+150	°C
P_{tot}	total power dissipation	DIP16 package	^[2] -	750	mW
		SO16, (T)SSOP16, and DHVQFN16 package	^[3] -	500	mW
P	power dissipation	per switch	-	100	mW

- [1] To avoid drawing V_{CC} current out of pins nZ, when switch current flows in pins nYn, the voltage drop across the bidirectional switch must not exceed 0.4 V. If the switch current flows into pins nZ, no V_{CC} current will flow out of pins nYn. In this case there is no limit for the voltage drop across the switch, but the voltages at pins nYn and nZ may not exceed V_{CC} or V_{EE} .
- [2] For DIP16 packages: above 70 °C the value of P_{tot} derates linearly with 12 mW/K.
- [3] For SO16 packages: above 70 °C the value of P_{tot} derates linearly with 8 mW/K.
 For SSOP16 and TSSOP16 packages: above 60 °C the value of P_{tot} derates linearly with 5.5 mW/K.
 For DHVQFN16 packages: above 60 °C the value of P_{tot} derates linearly with 4.5 mW/K.

9. Recommended operating conditions

Table 5. Recommended operating conditions

Symbol	Parameter	Conditions	74HC4052			74HCT4052			Unit
			Min	Typ	Max	Min	Typ	Max	
V _{CC}	supply voltage	see Figure 7 and Figure 8							
		V _{CC} – GND	2.0	5.0	10.0	4.5	5.0	5.5	V
		V _{CC} – V _{EE}	2.0	5.0	10.0	2.0	5.0	10.0	V
V _I	input voltage		GND	-	V _{CC}	GND	-	V _{CC}	V
V _{SW}	switch voltage		V _{EE}	-	V _{CC}	V _{EE}	-	V _{CC}	V
T _{amb}	ambient temperature		-40	+25	+125	-40	+25	+125	°C
Δt/ΔV	input transition rise and fall rate	V _{CC} = 2.0 V	-	-	625	-	-	-	ns/V
		V _{CC} = 4.5 V	-	1.67	139	-	1.67	139	ns/V
		V _{CC} = 6.0 V	-	-	83	-	-	-	ns/V
		V _{CC} = 10.0 V	-	-	31	-	-	-	ns/V

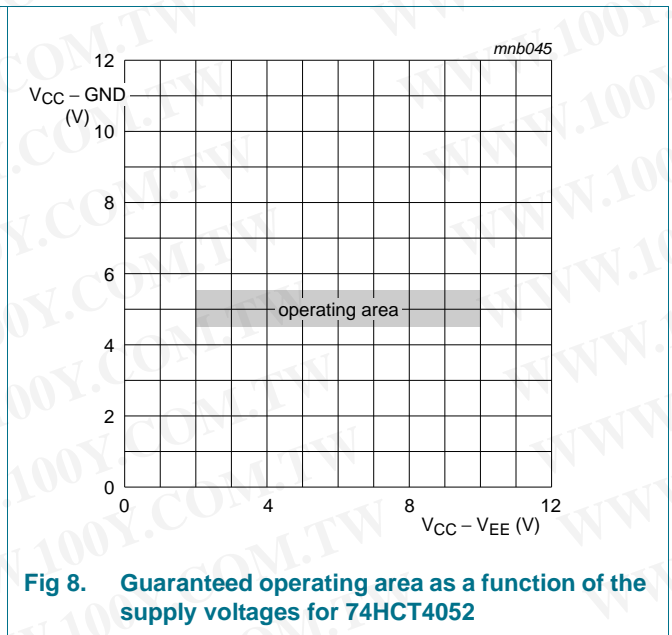
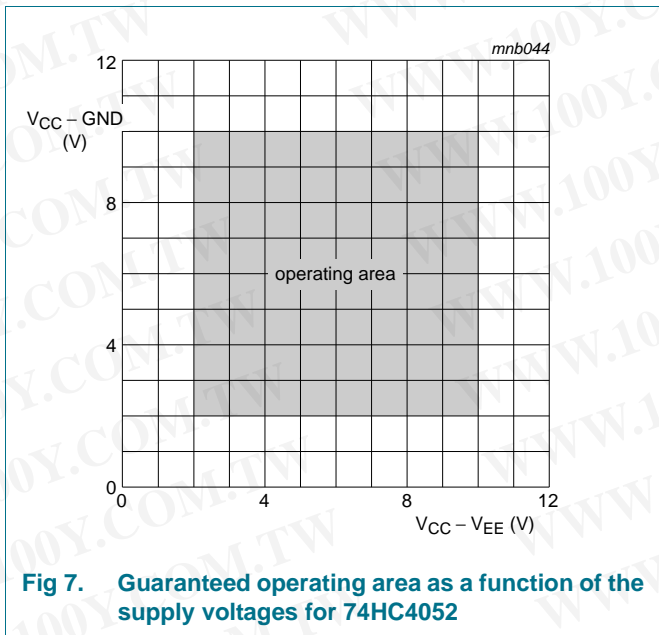

勝特力材料 886-3-5753170
 勝特力电子(上海) 86-21-34970699
 勝特力电子(深圳) 86-755-83298787
[Http://www.100y.com.tw](http://www.100y.com.tw)

10. Static characteristics

Table 6. R_{ON} resistance per switch for 74HC4052 and 74HCT4052

V_I = V_{IH} or V_{IL}; for test circuit see Figure 9.

V_{is} is the input voltage at a nYn or nZ terminal, whichever is assigned as an input.

V_{os} is the output voltage at a nYn or nZ terminal, whichever is assigned as an output.

For 74HC4052: V_{CC} – GND or V_{CC} – V_{EE} = 2.0 V, 4.5 V, 6.0 V and 9.0 V.

For 74HCT4052: V_{CC} – GND = 4.5 V and 5.5 V, V_{CC} – V_{EE} = 2.0 V, 4.5 V, 6.0 V and 9.0 V.

Symbol	Parameter	Conditions	Min	Typ	Max	Unit
T_{amb} = –40 °C to +85 °C						
R _{ON(peak)}	ON resistance (peak)	V _{is} = V _{CC} to V _{EE}				
		V _{CC} = 2.0 V; V _{EE} = 0 V; I _{SW} = 100 μA	[2]	-	-	Ω
		V _{CC} = 4.5 V; V _{EE} = 0 V; I _{SW} = 1000 μA	-	100	225	Ω
		V _{CC} = 6.0 V; V _{EE} = 0 V; I _{SW} = 1000 μA	-	90	200	Ω
		V _{CC} = 4.5 V; V _{EE} = –4.5 V; I _{SW} = 1000 μA	-	70	165	Ω
R _{ON(rail)}	ON resistance (rail)	V _{is} = V _{EE}				
		V _{CC} = 2.0 V; V _{EE} = 0 V; I _{SW} = 100 μA	[2]	-	150	Ω
		V _{CC} = 4.5 V; V _{EE} = 0 V; I _{SW} = 1000 μA	-	80	175	Ω
		V _{CC} = 6.0 V; V _{EE} = 0 V; I _{SW} = 1000 μA	-	70	150	Ω
		V _{CC} = 4.5 V; V _{EE} = –4.5 V; I _{SW} = 1000 μA	-	60	130	Ω
		V _{is} = V _{CC}				
		V _{CC} = 2.0 V; V _{EE} = 0 V; I _{SW} = 100 μA	[2]	-	150	Ω
		V _{CC} = 4.5 V; V _{EE} = 0 V; I _{SW} = 1000 μA	-	90	200	Ω
		V _{CC} = 6.0 V; V _{EE} = 0 V; I _{SW} = 1000 μA	-	80	175	Ω
		V _{CC} = 4.5 V; V _{EE} = –4.5 V; I _{SW} = 1000 μA	-	65	150	Ω
ΔR _{ON}	ON resistance mismatch between channels	V _{is} = V _{CC} to V _{EE}				
		V _{CC} = 2.0 V; V _{EE} = 0 V	[2]	-	-	Ω
		V _{CC} = 4.5 V; V _{EE} = 0 V	-	9	-	Ω
		V _{CC} = 6.0 V; V _{EE} = 0 V	-	8	-	Ω
		V _{CC} = 4.5 V; V _{EE} = –4.5 V	-	6	-	Ω
T_{amb} = –40 °C to +125 °C						
R _{ON(peak)}	ON resistance (peak)	V _{is} = V _{CC} to V _{EE}				
		V _{CC} = 2.0 V; V _{EE} = 0 V; I _{SW} = 100 μA	[2]	-	-	Ω
		V _{CC} = 4.5 V; V _{EE} = 0 V; I _{SW} = 1000 μA	-	-	270	Ω
		V _{CC} = 6.0 V; V _{EE} = 0 V; I _{SW} = 1000 μA	-	-	240	Ω
		V _{CC} = 4.5 V; V _{EE} = –4.5 V; I _{SW} = 1000 μA	-	-	195	Ω

勝特力材料 886-3-5753170
 勝特力电子(上海) 86-21-34970699
 勝特力电子(深圳) 86-755-83298787
[Http://www.100y.com.tw](http://www.100y.com.tw)

Table 6. R_{ON} resistance per switch for 74HC4052 and 74HCT4052 ...continued

$V_I = V_{IH}$ or V_{IL} ; for test circuit see Figure 9.

V_{is} is the input voltage at a nYn or nZ terminal, whichever is assigned as an input.

V_{os} is the output voltage at a nYn or nZ terminal, whichever is assigned as an output.

For 74HC4052: $V_{CC} - GND$ or $V_{CC} - V_{EE} = 2.0\text{ V}, 4.5\text{ V}, 6.0\text{ V}$ and 9.0 V .

For 74HCT4052: $V_{CC} - GND = 4.5\text{ V}$ and 5.5 V , $V_{CC} - V_{EE} = 2.0\text{ V}, 4.5\text{ V}, 6.0\text{ V}$ and 9.0 V .

Symbol	Parameter	Conditions	Min	Typ	Max	Unit	
$R_{ON(rail)}$	ON resistance (rail)	$V_{is} = V_{EE}$					
		$V_{CC} = 2.0\text{ V}; V_{EE} = 0\text{ V}; I_{SW} = 100\text{ }\mu\text{A}$	[2]	-	-	-	Ω
		$V_{CC} = 4.5\text{ V}; V_{EE} = 0\text{ V}; I_{SW} = 1000\text{ }\mu\text{A}$	-	-	210	Ω	
		$V_{CC} = 6.0\text{ V}; V_{EE} = 0\text{ V}; I_{SW} = 1000\text{ }\mu\text{A}$	-	-	180	Ω	
		$V_{CC} = 4.5\text{ V}; V_{EE} = -4.5\text{ V}; I_{SW} = 1000\text{ }\mu\text{A}$	-	-	160	Ω	
		$V_{is} = V_{CC}$					
		$V_{CC} = 2.0\text{ V}; V_{EE} = 0\text{ V}; I_{SW} = 100\text{ }\mu\text{A}$	[2]	-	-	-	Ω
		$V_{CC} = 4.5\text{ V}; V_{EE} = 0\text{ V}; I_{SW} = 1000\text{ }\mu\text{A}$	-	-	240	Ω	
		$V_{CC} = 6.0\text{ V}; V_{EE} = 0\text{ V}; I_{SW} = 1000\text{ }\mu\text{A}$	-	-	210	Ω	
		$V_{CC} = 4.5\text{ V}; V_{EE} = -4.5\text{ V}; I_{SW} = 1000\text{ }\mu\text{A}$	-	-	180	Ω	

[1] All typical values are measured at $T_{amb} = 25\text{ }^\circ\text{C}$.

[2] When supply voltages ($V_{CC} - V_{EE}$) near 2.0 V the analog switch ON resistance becomes extremely non-linear. When using a supply of 2 V, it is recommended to use these devices only for transmitting digital signals.

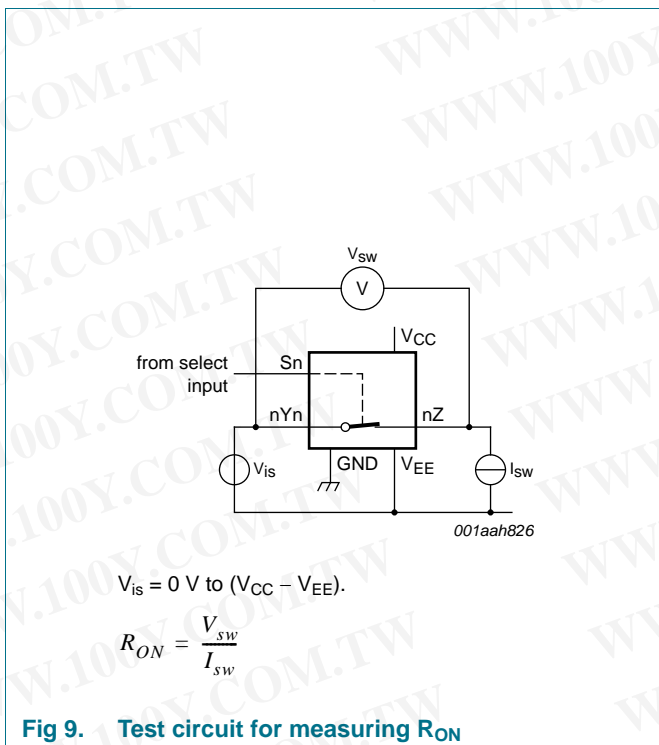

Fig 9. Test circuit for measuring R_{ON}

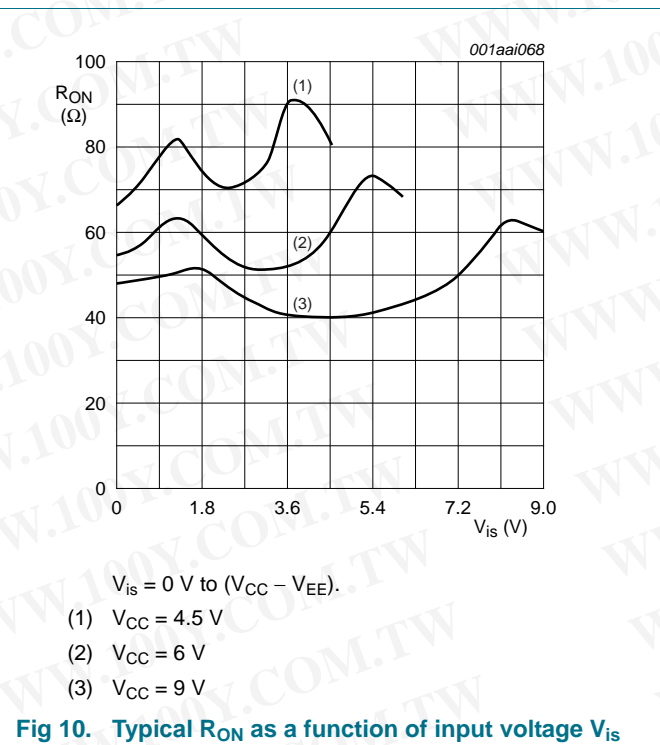

Fig 10. Typical R_{ON} as a function of input voltage V_{is}

勝特力材料 886-3-5753170
 勝特力电子(上海) 86-21-34970699
 勝特力电子(深圳) 86-755-83298787
[Http://www.100y.com.tw](http://www.100y.com.tw)

勝特力材料 886-3-5753170
 勝特力电子(上海) 86-21-34970699
 勝特力电子(深圳) 86-755-83298787
[Http://www.100y.com.tw](http://www.100y.com.tw)

Table 7. Static characteristics for 74HC4052

Voltages are referenced to GND (ground = 0 V).
V_{is} is the input voltage at pins nYn or nZ, whichever is assigned as an input.
V_{os} is the output voltage at pins nZ or nYn, whichever is assigned as an output.

Symbol	Parameter	Conditions	Min	Typ	Max	Unit
T_{amb} = -40 °C to +85 °C [1]						
V _{IH}	HIGH-level input voltage	V _{CC} = 2.0 V	1.5	1.2	-	V
		V _{CC} = 4.5 V	3.15	2.4	-	V
		V _{CC} = 6.0 V	4.2	3.2	-	V
		V _{CC} = 9.0 V	6.3	4.7	-	V
V _{IL}	LOW-level input voltage	V _{CC} = 2.0 V	-	0.8	0.5	V
		V _{CC} = 4.5 V	-	2.1	1.35	V
		V _{CC} = 6.0 V	-	2.8	1.8	V
		V _{CC} = 9.0 V	-	4.3	2.7	V
I _I	input leakage current	V _{EE} = 0 V; V _I = V _{CC} or GND				
		V _{CC} = 6.0 V	-	-	±1.0	µA
		V _{CC} = 10.0 V	-	-	±2.0	µA
I _{S(OFF)}	OFF-state leakage current	V _{CC} = 10.0 V; V _{EE} = 0 V; V _I = V _{IH} or V _{IL} ; V _{SW} = V _{CC} - V _{EE} ; see Figure 11				
		per channel	-	-	±1.0	µA
		all channels	-	-	±2.0	µA
I _{S(ON)}	ON-state leakage current	V _I = V _{IH} or V _{IL} ; V _{SW} = V _{CC} - V _{EE} ; V _{CC} = 10.0 V; V _{EE} = 0 V; see Figure 12	-	-	±2.0	µA
I _{CC}	supply current	V _{EE} = 0 V; V _I = V _{CC} or GND; V _{is} = V _{EE} or V _{CC} ; V _{os} = V _{CC} or V _{EE}				
		V _{CC} = 6.0 V	-	-	80.0	µA
		V _{CC} = 10.0 V	-	-	160.0	µA
C _I	input capacitance		-	3.5	-	pF
C _{SW}	switch capacitance	independent pins nYn	-	5	-	pF
		common pins nZ	-	12	-	pF
T_{amb} = -40 °C to +125 °C						
V _{IH}	HIGH-level input voltage	V _{CC} = 2.0 V	1.5	-	-	V
		V _{CC} = 4.5 V	3.15	-	-	V
		V _{CC} = 6.0 V	4.2	-	-	V
		V _{CC} = 9.0 V	6.3	-	-	V
V _{IL}	LOW-level input voltage	V _{CC} = 2.0 V	-	-	0.5	V
		V _{CC} = 4.5 V	-	-	1.35	V
		V _{CC} = 6.0 V	-	-	1.8	V
		V _{CC} = 9.0 V	-	-	2.7	V
I _I	input leakage current	V _{EE} = 0 V; V _I = V _{CC} or GND				
		V _{CC} = 6.0 V	-	-	±1.0	µA
		V _{CC} = 10.0 V	-	-	±2.0	µA

勝特力材料 886-3-5753170
 勝特力电子(上海) 86-21-34970699
 勝特力电子(深圳) 86-755-83298787
[Http://www.100y.com.tw](http://www.100y.com.tw)

Table 7. Static characteristics for 74HC4052 ...continued

Voltages are referenced to GND (ground = 0 V).
V_{is} is the input voltage at pins nYn or nZ, whichever is assigned as an input.
V_{os} is the output voltage at pins nZ or nYn, whichever is assigned as an output.

Symbol	Parameter	Conditions	Min	Typ	Max	Unit
I _{S(OFF)}	OFF-state leakage current	V _{CC} = 10.0 V; V _{EE} = 0 V; V _I = V _{IH} or V _{IL} ; V _{SW} = V _{CC} - V _{EE} ; see Figure 11				
		per channel	-	-	±1.0	µA
		all channels	-	-	±2.0	µA
I _{S(ON)}	ON-state leakage current	V _I = V _{IH} or V _{IL} ; V _{SW} = V _{CC} - V _{EE} ; V _{CC} = 10.0 V; V _{EE} = 0 V; see Figure 12	-	-	±2.0	µA
I _{CC}	supply current	V _{EE} = 0 V; V _I = V _{CC} or GND; V _{is} = V _{EE} or V _{CC} ; V _{os} = V _{CC} or V _{EE}				
		V _{CC} = 6.0 V	-	-	160.0	µA
		V _{CC} = 10.0 V	-	-	320.0	µA

[1] All typical values are measured at T_{amb} = 25 °C.

Table 8. Static characteristics for 74HCT4052

Voltages are referenced to GND (ground = 0 V).
V_{is} is the input voltage at pins nYn or nZ, whichever is assigned as an input.
V_{os} is the output voltage at pins nZ or nYn, whichever is assigned as an output.

Symbol	Parameter	Conditions	Min	Typ	Max	Unit
T_{amb} = -40 °C to +85 °C [1]						
V _{IH}	HIGH-level input voltage	V _{CC} = 4.5 V to 5.5 V	2.0	1.6	-	V
V _{IL}	LOW-level input voltage	V _{CC} = 4.5 V to 5.5 V	-	1.2	0.8	V
I _I	input leakage current	V _I = V _{CC} or GND; V _{CC} = 5.5 V; V _{EE} = 0 V	-	-	±1.0	µA
I _{S(OFF)}	OFF-state leakage current	V _{CC} = 10.0 V; V _{EE} = 0 V; V _I = V _{IH} or V _{IL} ; V _{SW} = V _{CC} - V _{EE} ; see Figure 11				
		per channel	-	-	±1.0	µA
		all channels	-	-	±2.0	µA
I _{S(ON)}	ON-state leakage current	V _{CC} = 10.0 V; V _{EE} = 0 V; V _I = V _{IH} or V _{IL} ; V _{SW} = V _{CC} - V _{EE} ; see Figure 12	-	-	±2.0	µA
I _{CC}	supply current	V _I = V _{CC} or GND; V _{is} = V _{EE} or V _{CC} ; V _{os} = V _{CC} or V _{EE}				
		V _{CC} = 5.5 V; V _{EE} = 0 V	-	-	80.0	µA
		V _{CC} = 5.0 V; V _{EE} = -5.0 V	-	-	160.0	µA
ΔI _{CC}	additional supply current	per input; V _I = V _{CC} - 2.1 V; other inputs at V _{CC} or GND; V _{CC} = 4.5 V to 5.5 V; V _{EE} = 0 V	-	45	202.5	µA
C _I	input capacitance		-	3.5	-	pF
C _{SW}	switch capacitance	independent pins nYn	-	5	-	pF
		common pins nZ	-	12	-	pF
T_{amb} = -40 °C to +125 °C						
V _{IH}	HIGH-level input voltage	V _{CC} = 4.5 V to 5.5 V	2.0	-	-	V

勝特力材料 886-3-5753170
 勝特力电子(上海) 86-21-34970699
 勝特力电子(深圳) 86-755-83298787
[Http://www.100y.com.tw](http://www.100y.com.tw)

Table 8. Static characteristics for 74HCT4052 ...continued

Voltages are referenced to GND (ground = 0 V).
 V_{is} is the input voltage at pins nY_n or nZ , whichever is assigned as an input.
 V_{os} is the output voltage at pins nZ or nY_n , whichever is assigned as an output.

Symbol	Parameter	Conditions	Min	Typ	Max	Unit
V_{IL}	LOW-level input voltage	$V_{CC} = 4.5\text{ V to }5.5\text{ V}$	-	-	0.8	V
I_I	input leakage current	$V_I = V_{CC}$ or GND; $V_{CC} = 5.5\text{ V}$; $V_{EE} = 0\text{ V}$	-	-	± 1.0	μA
$I_{S(OFF)}$	OFF-state leakage current	$V_{CC} = 10.0\text{ V}$; $V_{EE} = 0\text{ V}$; $V_I = V_{IH}$ or V_{IL} ; $ V_{SW} = V_{CC} - V_{EE}$; see Figure 11	-	-	± 1.0	μA
		per channel	-	-	± 1.0	μA
		all channels	-	-	± 2.0	μA
$I_{S(ON)}$	ON-state leakage current	$V_{CC} = 10.0\text{ V}$; $V_{EE} = 0\text{ V}$; $V_I = V_{IH}$ or V_{IL} ; $ V_{SW} = V_{CC} - V_{EE}$; see Figure 12	-	-	± 2.0	μA
I_{CC}	supply current	$V_I = V_{CC}$ or GND; $V_{is} = V_{EE}$ or V_{CC} ; $V_{os} = V_{CC}$ or V_{EE}	-	-	-	-
		$V_{CC} = 5.5\text{ V}$; $V_{EE} = 0\text{ V}$	-	-	160.0	μA
		$V_{CC} = 5.0\text{ V}$; $V_{EE} = -5.0\text{ V}$	-	-	320.0	μA
ΔI_{CC}	additional supply current	per input; $V_I = V_{CC} - 2.1\text{ V}$; other inputs at V_{CC} or GND; $V_{CC} = 4.5\text{ V to }5.5\text{ V}$; $V_{EE} = 0\text{ V}$	-	-	220.5	μA

[1] All typical values are measured at $T_{amb} = 25\text{ }^\circ\text{C}$.

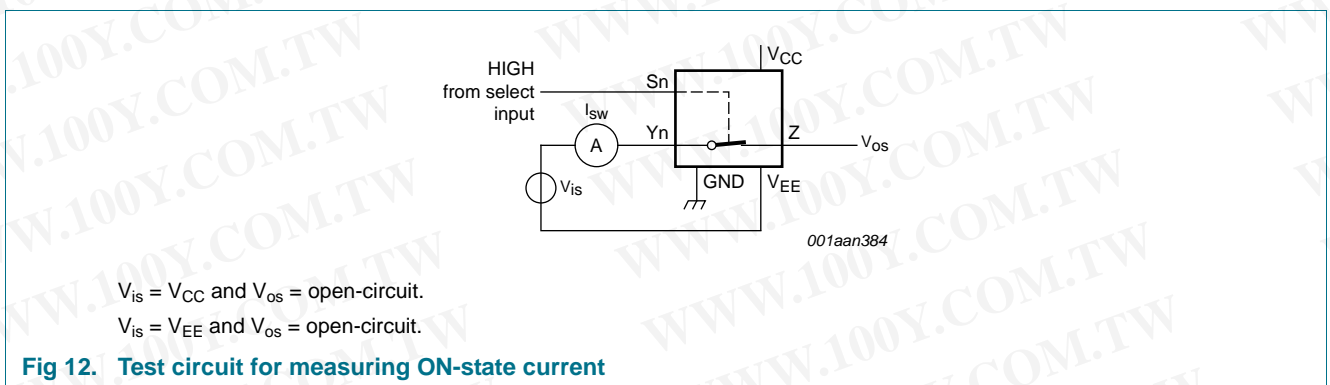
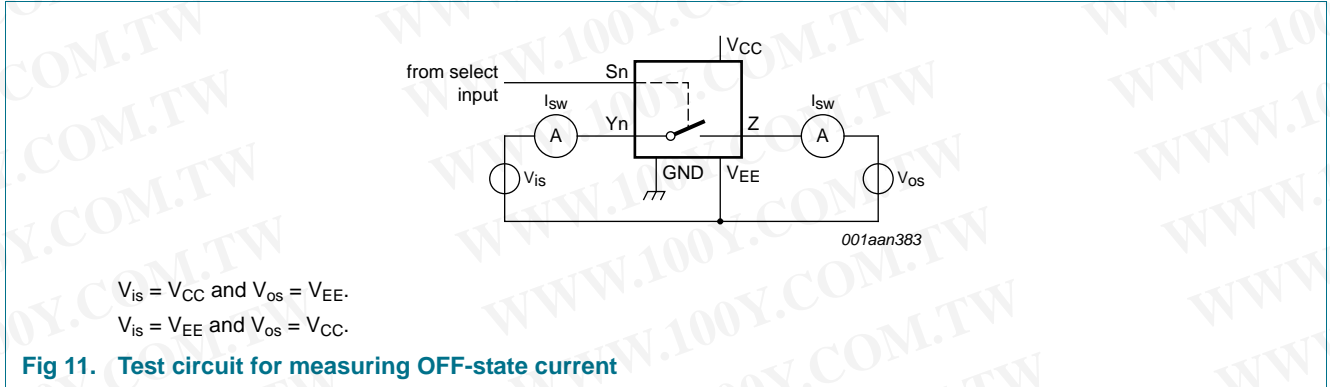

11. Dynamic characteristics

勝特力材料 886-3-5753170
 勝特力电子(上海) 86-21-34970699
 勝特力电子(深圳) 86-755-83298787
[Http://www.100y.com.tw](http://www.100y.com.tw)

Table 9. Dynamic characteristics for 74HC4052

$GND = 0\text{ V}$; $t_r = t_f = 6\text{ ns}$; $C_L = 50\text{ pF}$; for test circuit see [Figure 15](#).
 V_{is} is the input voltage at a nYn or nZ terminal, whichever is assigned as an input.
 V_{os} is the output voltage at a nYn or nZ terminal, whichever is assigned as an output.

Symbol	Parameter	Conditions	Min	Typ	Max	Unit		
$T_{amb} = -40\text{ °C to }+85\text{ °C}$[1]								
t_{pd}	propagation delay	V_{is} to V_{os} ; $R_L = \infty\ \Omega$; see Figure 13	[2]					
		$V_{CC} = 2.0\text{ V}$; $V_{EE} = 0\text{ V}$	-	14	75	ns		
		$V_{CC} = 4.5\text{ V}$; $V_{EE} = 0\text{ V}$	-	5	15	ns		
		$V_{CC} = 6.0\text{ V}$; $V_{EE} = 0\text{ V}$	-	4	13	ns		
t_{on}	turn-on time	\bar{E} , Sn to V_{os} ; $R_L = \infty\ \Omega$; see Figure 14	[3]					
		$V_{CC} = 2.0\text{ V}$; $V_{EE} = 0\text{ V}$	-	105	405	ns		
		$V_{CC} = 4.5\text{ V}$; $V_{EE} = 0\text{ V}$	-	38	81	ns		
		$V_{CC} = 5.0\text{ V}$; $V_{EE} = 0\text{ V}$; $C_L = 15\text{ pF}$	-	28	-	ns		
		$V_{CC} = 6.0\text{ V}$; $V_{EE} = 0\text{ V}$	-	30	69	ns		
t_{off}	turn-off time	\bar{E} , Sn to V_{os} ; $R_L = 1\text{ k}\Omega$; see Figure 14	[4]					
		$V_{CC} = 2.0\text{ V}$; $V_{EE} = 0\text{ V}$	-	74	315	ns		
		$V_{CC} = 4.5\text{ V}$; $V_{EE} = 0\text{ V}$	-	27	63	ns		
		$V_{CC} = 5.0\text{ V}$; $V_{EE} = 0\text{ V}$; $C_L = 15\text{ pF}$	-	21	-	ns		
		$V_{CC} = 6.0\text{ V}$; $V_{EE} = 0\text{ V}$	-	22	54	ns		
C_{PD}	power dissipation capacitance	per switch; $V_I = GND$ to V_{CC}	[5]	-	57	-	pF	
		$T_{amb} = -40\text{ °C to }+125\text{ °C}$						
		t_{pd}	propagation delay	V_{is} to V_{os} ; $R_L = \infty\ \Omega$; see Figure 13	[2]			
				$V_{CC} = 2.0\text{ V}$; $V_{EE} = 0\text{ V}$	-	-	90	ns
				$V_{CC} = 4.5\text{ V}$; $V_{EE} = 0\text{ V}$	-	-	18	ns
$V_{CC} = 6.0\text{ V}$; $V_{EE} = 0\text{ V}$	-			-	15	ns		
t_{on}	turn-on time	\bar{E} , Sn to V_{os} ; $R_L = \infty\ \Omega$; see Figure 14	[3]					
		$V_{CC} = 2.0\text{ V}$; $V_{EE} = 0\text{ V}$	-	-	490	ns		
		$V_{CC} = 4.5\text{ V}$; $V_{EE} = 0\text{ V}$	-	-	98	ns		
		$V_{CC} = 6.0\text{ V}$; $V_{EE} = 0\text{ V}$	-	-	83	ns		
		$V_{CC} = 4.5\text{ V}$; $V_{EE} = -4.5\text{ V}$	-	-	69	ns		

Table 9. Dynamic characteristics for 74HC4052 ...continued

$GND = 0\text{ V}$; $t_r = t_f = 6\text{ ns}$; $C_L = 50\text{ pF}$; for test circuit see [Figure 15](#).

V_{is} is the input voltage at a nYn or nZ terminal, whichever is assigned as an input.

V_{os} is the output voltage at a nYn or nZ terminal, whichever is assigned as an output.

Symbol	Parameter	Conditions	Min	Typ	Max	Unit
t_{off}	turn-off time	\bar{E} , Sn to V_{os} ; $R_L = 1\text{ k}\Omega$; see Figure 14	[4]	-	-	-
		$V_{CC} = 2.0\text{ V}$; $V_{EE} = 0\text{ V}$	-	-	375	ns
		$V_{CC} = 4.5\text{ V}$; $V_{EE} = 0\text{ V}$	-	-	75	ns
		$V_{CC} = 6.0\text{ V}$; $V_{EE} = 0\text{ V}$	-	-	64	ns
		$V_{CC} = 4.5\text{ V}$; $V_{EE} = -4.5\text{ V}$	-	-	57	ns

- [1] All typical values are measured at $T_{amb} = 25\text{ }^\circ\text{C}$.
- [2] t_{pd} is the same as t_{pHL} and t_{pLH} .
- [3] t_{on} is the same as t_{pZH} and t_{pZL} .
- [4] t_{off} is the same as t_{pHZ} and t_{pLZ} .
- [5] C_{PD} is used to determine the dynamic power dissipation (P_D in μW).
 $P_D = C_{PD} \times V_{CC}^2 \times f_i \times N + \Sigma\{(C_L + C_{sw}) \times V_{CC}^2 \times f_o\}$ where:
 f_i = input frequency in MHz;
 f_o = output frequency in MHz;
 N = number of inputs switching;
 $\Sigma\{(C_L + C_{sw}) \times V_{CC}^2 \times f_o\}$ = sum of outputs;
 C_L = output load capacitance in pF;
 C_{sw} = switch capacitance in pF;
 V_{CC} = supply voltage in V.

勝特力材料 886-3-5753170
勝特力电子(上海) 86-21-34970699
勝特力电子(深圳) 86-755-83298787
[Http://www.100y.com.tw](http://www.100y.com.tw)

Table 10. Dynamic characteristics for 74HCT4052

$GND = 0\text{ V}$; $t_r = t_f = 6\text{ ns}$; $C_L = 50\text{ pF}$; for test circuit see [Figure 15](#).

V_{is} is the input voltage at a nYn or nZ terminal, whichever is assigned as an input.

V_{os} is the output voltage at a nYn or nZ terminal, whichever is assigned as an output.

Symbol	Parameter	Conditions	Min	Typ	Max	Unit
$T_{amb} = -40\text{ }^\circ\text{C to } +85\text{ }^\circ\text{C}$[1]						
t_{pd}	propagation delay	V_{is} to V_{os} ; $R_L = \infty\ \Omega$; see Figure 13	[2]	-	-	-
		$V_{CC} = 4.5\text{ V}$; $V_{EE} = 0\text{ V}$	-	5	15	ns
		$V_{CC} = 4.5\text{ V}$; $V_{EE} = -4.5\text{ V}$	-	4	10	ns
t_{on}	turn-on time	\bar{E} , Sn to V_{os} ; $R_L = 1\text{ k}\Omega$; see Figure 14	[3]	-	-	-
		$V_{CC} = 4.5\text{ V}$; $V_{EE} = 0\text{ V}$	-	41	88	ns
		$V_{CC} = 5.0\text{ V}$; $V_{EE} = 0\text{ V}$; $C_L = 15\text{ pF}$	-	18	-	ns
		$V_{CC} = 4.5\text{ V}$; $V_{EE} = -4.5\text{ V}$	-	28	60	ns
t_{off}	turn-off time	\bar{E} , Sn to V_{os} ; $R_L = 1\text{ k}\Omega$; see Figure 14	[4]	-	-	-
		$V_{CC} = 4.5\text{ V}$; $V_{EE} = 0\text{ V}$	-	26	63	ns
		$V_{CC} = 5.0\text{ V}$; $V_{EE} = 0\text{ V}$; $C_L = 15\text{ pF}$	-	13	-	ns
		$V_{CC} = 4.5\text{ V}$; $V_{EE} = -4.5\text{ V}$	-	21	48	ns
C_{PD}	power dissipation capacitance	per switch; $V_I = GND$ to $V_{CC} - 1.5\text{ V}$	[5]	57	-	pF

Table 10. Dynamic characteristics for 74HCT4052 ...continued

$GND = 0\text{ V}$; $t_r = t_f = 6\text{ ns}$; $C_L = 50\text{ pF}$; for test circuit see [Figure 15](#).

V_{is} is the input voltage at a nYn or nZ terminal, whichever is assigned as an input.

V_{os} is the output voltage at a nYn or nZ terminal, whichever is assigned as an output.

Symbol	Parameter	Conditions	Min	Typ	Max	Unit
$T_{amb} = -40\text{ °C to }+125\text{ °C}$						
t_{pd}	propagation delay	V_{is} to V_{os} ; $R_L = \infty\ \Omega$; see Figure 13	[2]			
		$V_{CC} = 4.5\text{ V}$; $V_{EE} = 0\text{ V}$	-	-	18	ns
		$V_{CC} = 4.5\text{ V}$; $V_{EE} = -4.5\text{ V}$	-	-	12	ns
t_{on}	turn-on time	\bar{E} , Sn to V_{os} ; $R_L = 1\text{ k}\Omega$; see Figure 14	[3]			
		$V_{CC} = 4.5\text{ V}$; $V_{EE} = 0\text{ V}$	-	-	105	ns
		$V_{CC} = 4.5\text{ V}$; $V_{EE} = -4.5\text{ V}$	-	-	72	ns
t_{off}	turn-off time	\bar{E} , Sn to V_{os} ; $R_L = 1\text{ k}\Omega$; see Figure 14	[4]			
		$V_{CC} = 4.5\text{ V}$; $V_{EE} = 0\text{ V}$	-	-	75	ns
		$V_{CC} = 4.5\text{ V}$; $V_{EE} = -4.5\text{ V}$	-	-	57	ns

- [1] All typical values are measured at $T_{amb} = 25\text{ °C}$.
- [2] t_{pd} is the same as t_{PHL} and t_{PLH} .
- [3] t_{on} is the same as t_{PZH} and t_{PZL} .
- [4] t_{off} is the same as t_{PHZ} and t_{PLZ} .
- [5] C_{PD} is used to determine the dynamic power dissipation (P_D in μW).
 $P_D = C_{PD} \times V_{CC}^2 \times f_i \times N + \Sigma\{(C_L + C_{sw}) \times V_{CC}^2 \times f_o\}$ where:
 f_i = input frequency in MHz;
 f_o = output frequency in MHz;
 N = number of inputs switching;
 $\Sigma\{(C_L + C_{sw}) \times V_{CC}^2 \times f_o\}$ = sum of outputs;
 C_L = output load capacitance in pF;
 C_{sw} = switch capacitance in pF;
 V_{CC} = supply voltage in V.

勝特力材料 886-3-5753170
勝特力电子(上海) 86-21-34970699
勝特力电子(深圳) 86-755-83298787
[Http://www.100y.com.tw](http://www.100y.com.tw)

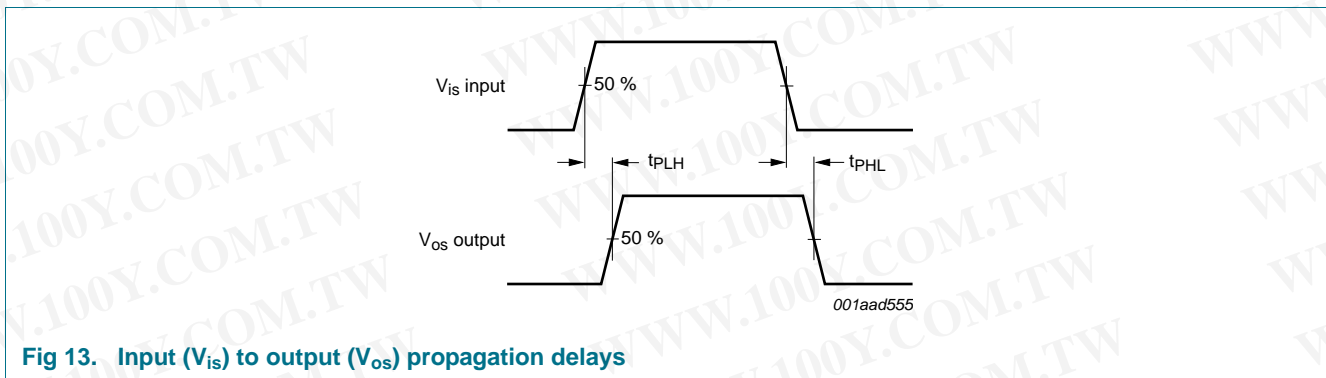
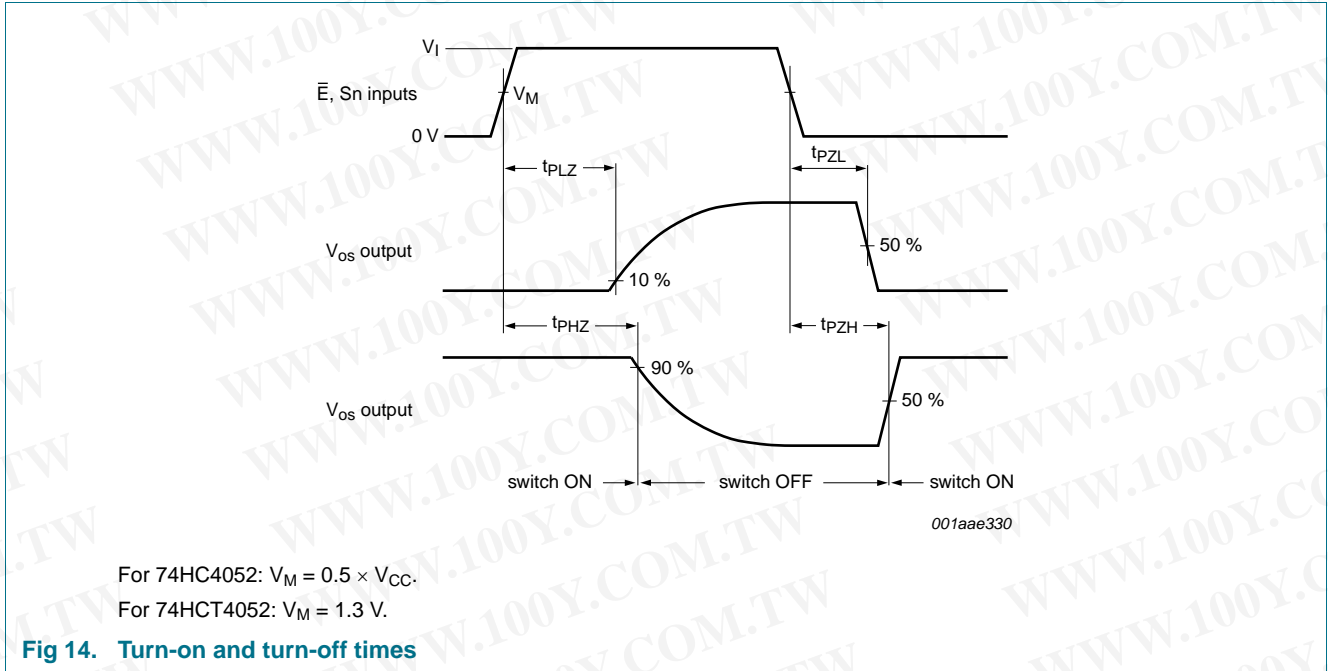
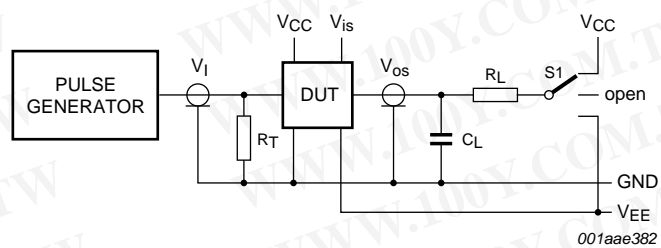
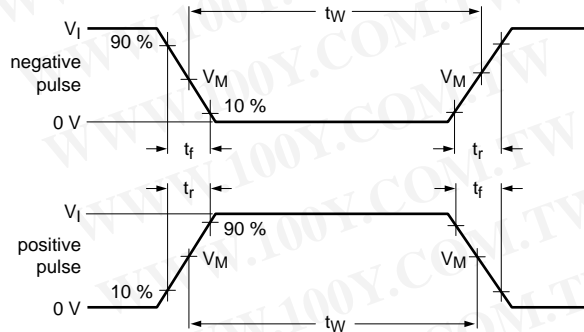

Fig 13. Input (V_{is}) to output (V_{os}) propagation delays



勝特力材料 886-3-5753170
 勝特力电子(上海) 86-21-34970699
 勝特力电子(深圳) 86-755-83298787
[Http://www.100y.com.tw](http://www.100y.com.tw)



Definitions for test circuit; see [Table 11](#):
 R_T = termination resistance should be equal to the output impedance Z_o of the pulse generator.
 C_L = load capacitance including jig and probe capacitance.
 R_L = load resistance.
 $S1$ = Test selection switch.

Fig 15. Test circuit for measuring AC performance

Table 11. Test data

Test	Input				Load		S1 position
	V _I	V _{is}	t _r , t _f		C _L	R _L	
			at f _{max}	other ^[1]			
t _{PHL} , t _{PLH}	[2]	pulse	< 2 ns	6 ns	50 pF	1 kΩ	open
t _{PZH} , t _{PHZ}	[2]	V _{CC}	< 2 ns	6 ns	50 pF	1 kΩ	V _{EE}
t _{PZL} , t _{PLZ}	[2]	V _{EE}	< 2 ns	6 ns	50 pF	1 kΩ	V _{CC}

[1] t_r = t_f = 6 ns; when measuring f_{max}, there is no constraint to t_r and t_f with 50 % duty factor.

[2] V_I values:

- a) For 74HC4052: V_I = V_{CC}
- b) For 74HCT4052: V_I = 3 V

勝特力材料 886-3-5753170
 勝特力电子(上海) 86-21-34970699
 勝特力电子(深圳) 86-755-83298787
[Http://www.100y.com.tw](http://www.100y.com.tw)

12. Additional dynamic characteristics

Table 12. Additional dynamic characteristics

Recommended conditions and typical values; GND = 0 V; T_{amb} = 25 °C; C_L = 50 pF.

V_{is} is the input voltage at pins nYn or nZ, whichever is assigned as an input.

V_{os} is the output voltage at pins nYn or nZ, whichever is assigned as an output.

Symbol	Parameter	Conditions	Min	Typ	Max	Unit	
d _{sin}	sine-wave distortion	f _i = 1 kHz; R _L = 10 kΩ; see Figure 16					
		V _{is} = 4.0 V (p-p); V _{CC} = 2.25 V; V _{EE} = -2.25 V	-	0.04	-	%	
		V _{is} = 8.0 V (p-p); V _{CC} = 4.5 V; V _{EE} = -4.5 V	-	0.02	-	%	
		f _i = 10 kHz; R _L = 10 kΩ; see Figure 16					
		V _{is} = 4.0 V (p-p); V _{CC} = 2.25 V; V _{EE} = -2.25 V	-	0.12	-	%	
		V _{is} = 8.0 V (p-p); V _{CC} = 4.5 V; V _{EE} = -4.5 V	-	0.06	-	%	
α _{iso}	isolation (OFF-state)	R _L = 600 Ω; f _i = 1 MHz; see Figure 17					
		V _{CC} = 2.25 V; V _{EE} = -2.25 V	[1]	-	-50	-	dB
		V _{CC} = 4.5 V; V _{EE} = -4.5 V	[1]	-	-50	-	dB
Xtalk	crosstalk	between two switches/multiplexers; R _L = 600 Ω; f _i = 1 MHz; see Figure 18					
		V _{CC} = 2.25 V; V _{EE} = -2.25 V	[1]	-	-60	-	dB
		V _{CC} = 4.5 V; V _{EE} = -4.5 V	[1]	-	-60	-	dB
V _{ct}	crosstalk voltage	peak-to-peak value; between control and any switch; R _L = 600 Ω; f _i = 1 MHz; E or Sn square wave between V _{CC} and GND; t _r = t _f = 6 ns; see Figure 19					
		V _{CC} = 4.5 V; V _{EE} = 0 V	-	110	-	mV	
		V _{CC} = 4.5 V; V _{EE} = -4.5 V	-	220	-	mV	
		f _(-3dB)	-3 dB frequency response	R _L = 50 Ω; see Figure 20			
V _{CC} = 2.25 V; V _{EE} = -2.25 V	[2]	-		170	-	MHz	
V _{CC} = 4.5 V; V _{EE} = -4.5 V	[2]	-		180	-	MHz	

[1] Adjust input voltage V_{is} to 0 dBm level (0 dBm = 1 mW into 600 Ω).

[2] Adjust input voltage V_{is} to 0 dBm level at V_{os} for 1 MHz (0 dBm = 1 mW into 50 Ω).

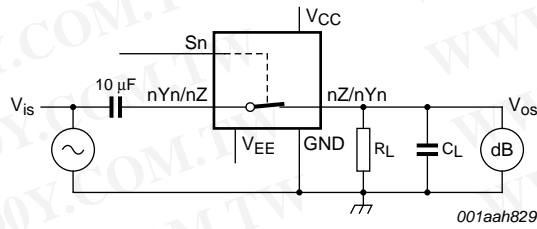
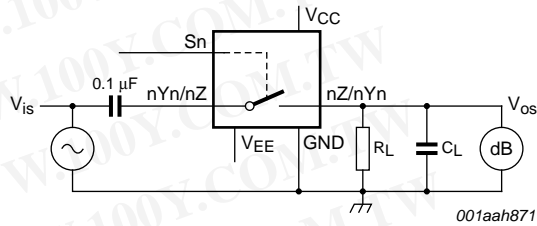
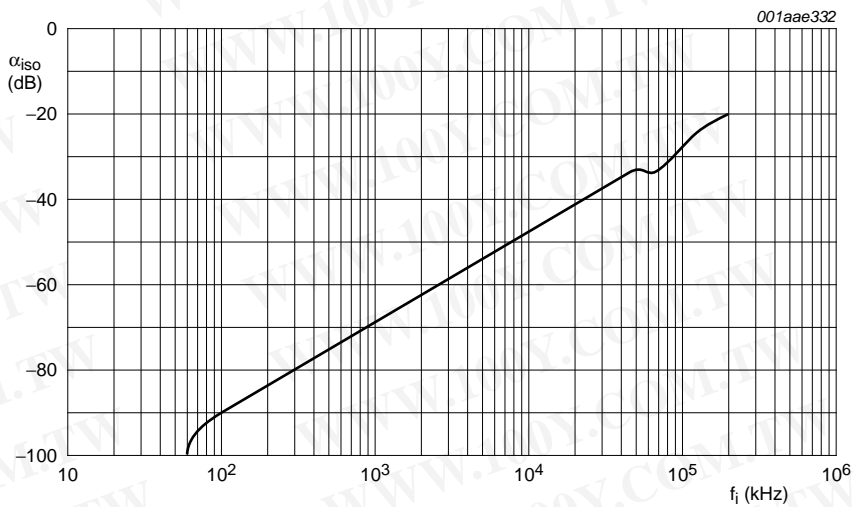

Fig 16. Test circuit for measuring sine-wave distortion



$V_{CC} = 4.5\text{ V}$; $GND = 0\text{ V}$; $V_{EE} = -4.5\text{ V}$; $R_L = 600\ \Omega$; $R_S = 1\text{ k}\Omega$.

a. Test circuit



b. Isolation (OFF-state) as a function of frequency

Fig 17. Test circuit for measuring isolation (OFF-state)

勝特力材料 886-3-5753170
 勝特力电子(上海) 86-21-34970699
 勝特力电子(深圳) 86-755-83298787
[Http://www.100y.com.tw](http://www.100y.com.tw)

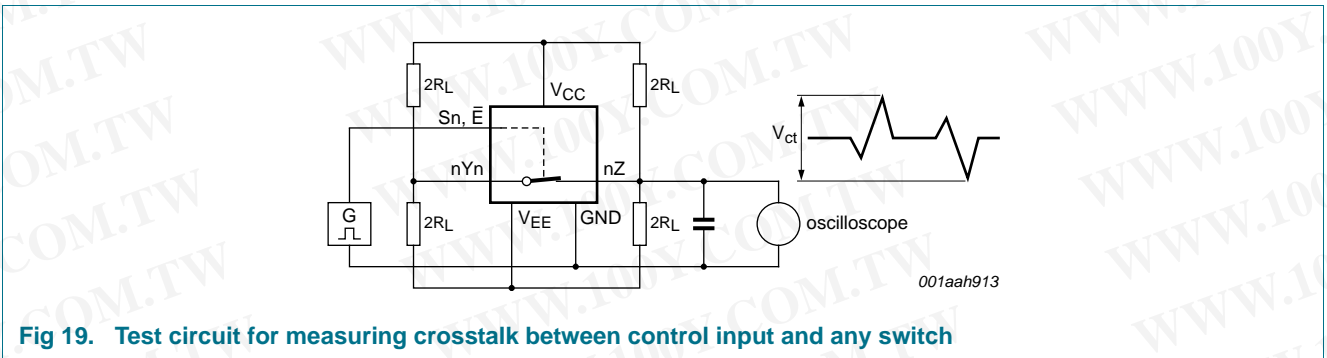
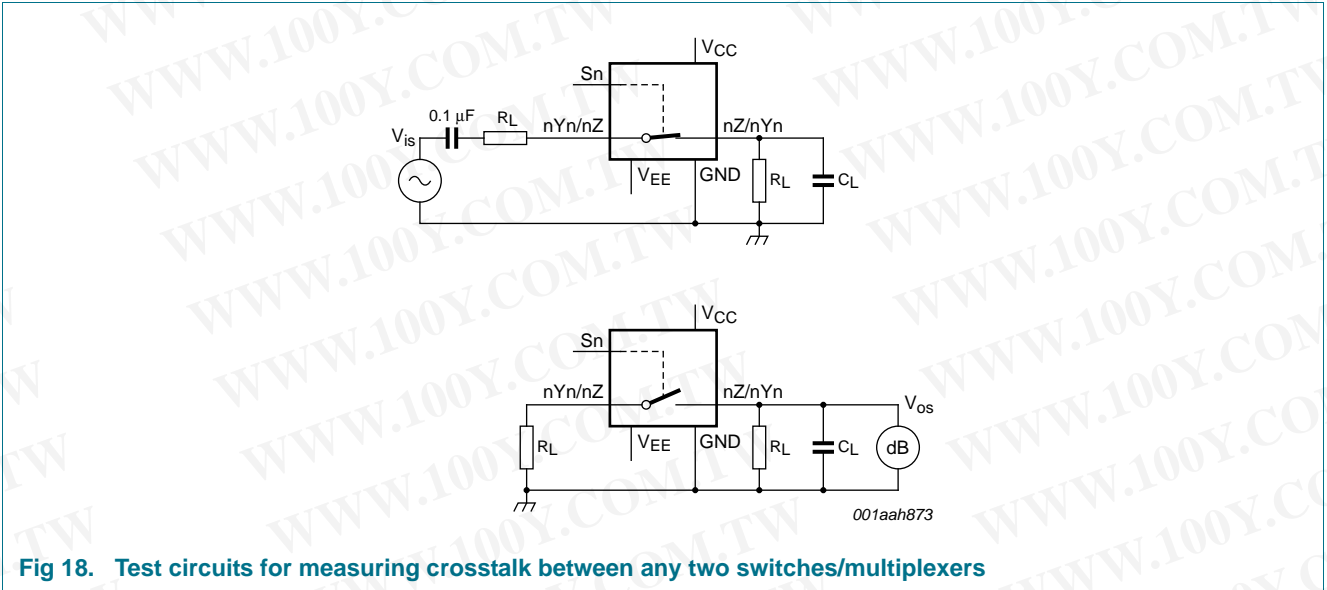

勝特力材料 886-3-5753170
 勝特力电子(上海) 86-21-34970699
 勝特力电子(深圳) 86-755-83298787
[Http://www.100y.com.tw](http://www.100y.com.tw)

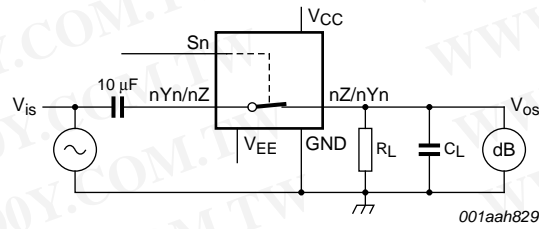

$V_{CC} = 4.5\text{ V}$; $GND = 0\text{ V}$; $V_{EE} = -4.5\text{ V}$; $R_L = 50\ \Omega$; $R_S = 1\text{ k}\Omega$.

a. Test circuit

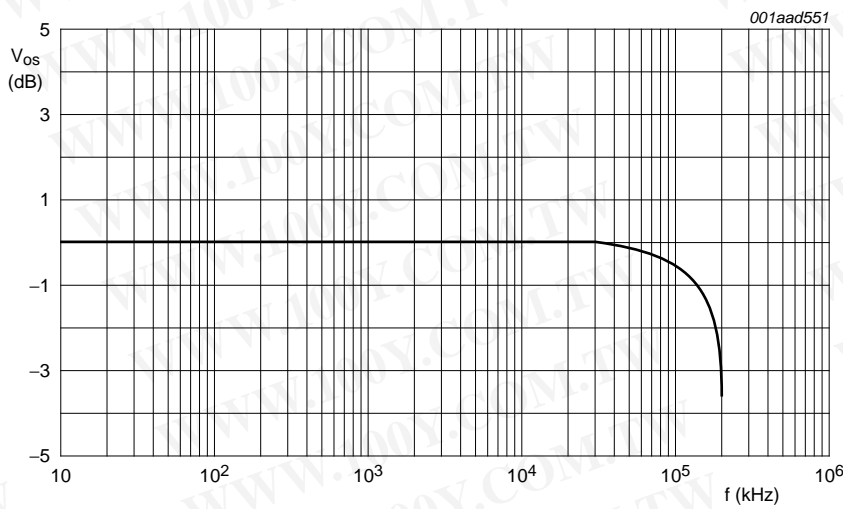

b. Typical frequency response

Fig 20. Test circuit for frequency response

勝特力材料 886-3-5753170
 勝特力电子(上海) 86-21-34970699
 勝特力电子(深圳) 86-755-83298787
[Http://www.100y.com.tw](http://www.100y.com.tw)

13. Package outline

SO16: plastic small outline package; 16 leads; body width 3.9 mm

SOT109-1

勝特力材料 886-3-5753170
 勝特力电子(上海) 86-21-34970699
 勝特力电子(深圳) 86-755-83298787
[Http://www.100y.com.tw](http://www.100y.com.tw)

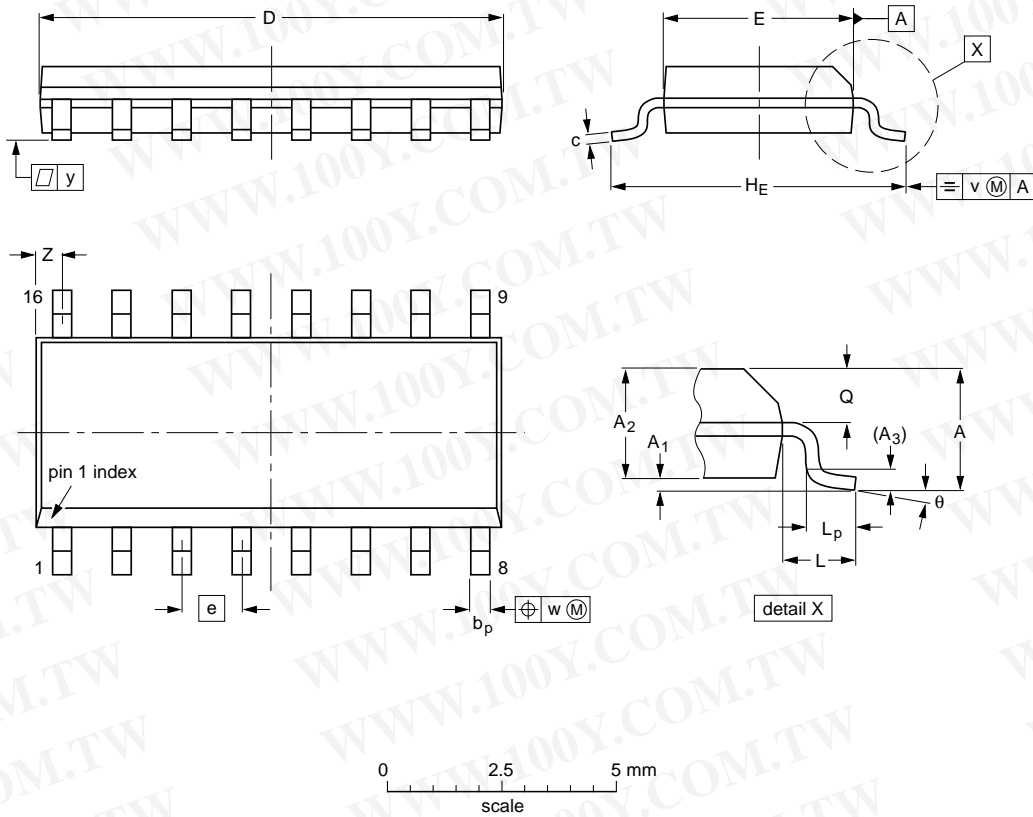

DIMENSIONS (inch dimensions are derived from the original mm dimensions)

UNIT	A max.	A ₁	A ₂	A ₃	b _p	c	D ⁽¹⁾	E ⁽¹⁾	e	H _E	L	L _p	Q	v	w	y	Z ⁽¹⁾	θ
mm	1.75	0.25 0.10	1.45 1.25	0.25	0.49 0.36	0.25 0.19	10.0 9.8	4.0 3.8	1.27	6.2 5.8	1.05	1.0 0.4	0.7 0.6	0.25	0.25	0.1	0.7 0.3	8° 0°
inches	0.069	0.010 0.004	0.057 0.049	0.01	0.019 0.014	0.010 0.0075	0.39 0.38	0.16 0.15	0.05	0.244 0.228	0.041	0.039 0.016	0.028 0.020	0.01	0.01	0.004	0.028 0.012	

Note

1. Plastic or metal protrusions of 0.15 mm (0.006 inch) maximum per side are not included.

OUTLINE VERSION	REFERENCES			EUROPEAN PROJECTION	ISSUE DATE
	IEC	JEDEC	JEITA		
SOT109-1	076E07	MS-012			99-12-27 03-02-19

Fig 21. Package outline SOT109-1 (SO16)

勝特力材料 886-3-5753170
 勝特力电子(上海) 86-21-34970699
 勝特力电子(深圳) 86-755-83298787
[Http://www.100y.com.tw](http://www.100y.com.tw)

SSOP16: plastic shrink small outline package; 16 leads; body width 5.3 mm

SOT338-1

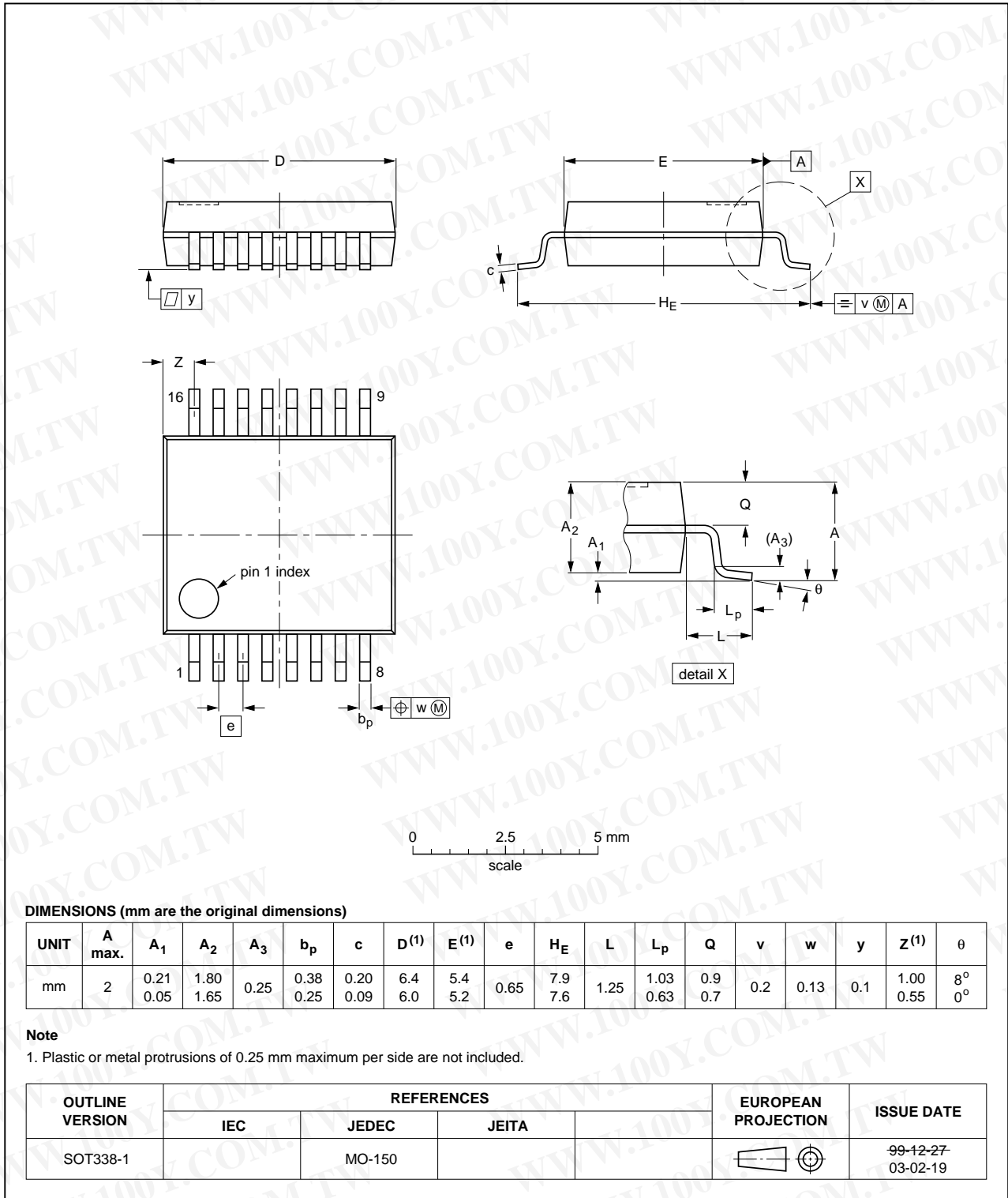

Fig 22. Package outline SOT338-1 (SSOP16)

勝特力材料 886-3-5753170
 勝特力电子(上海) 86-21-34970699
 勝特力电子(深圳) 86-755-83298787
 Http://www.100y.com.tw

DIP16: plastic dual in-line package; 16 leads (300 mil)

SOT38-4

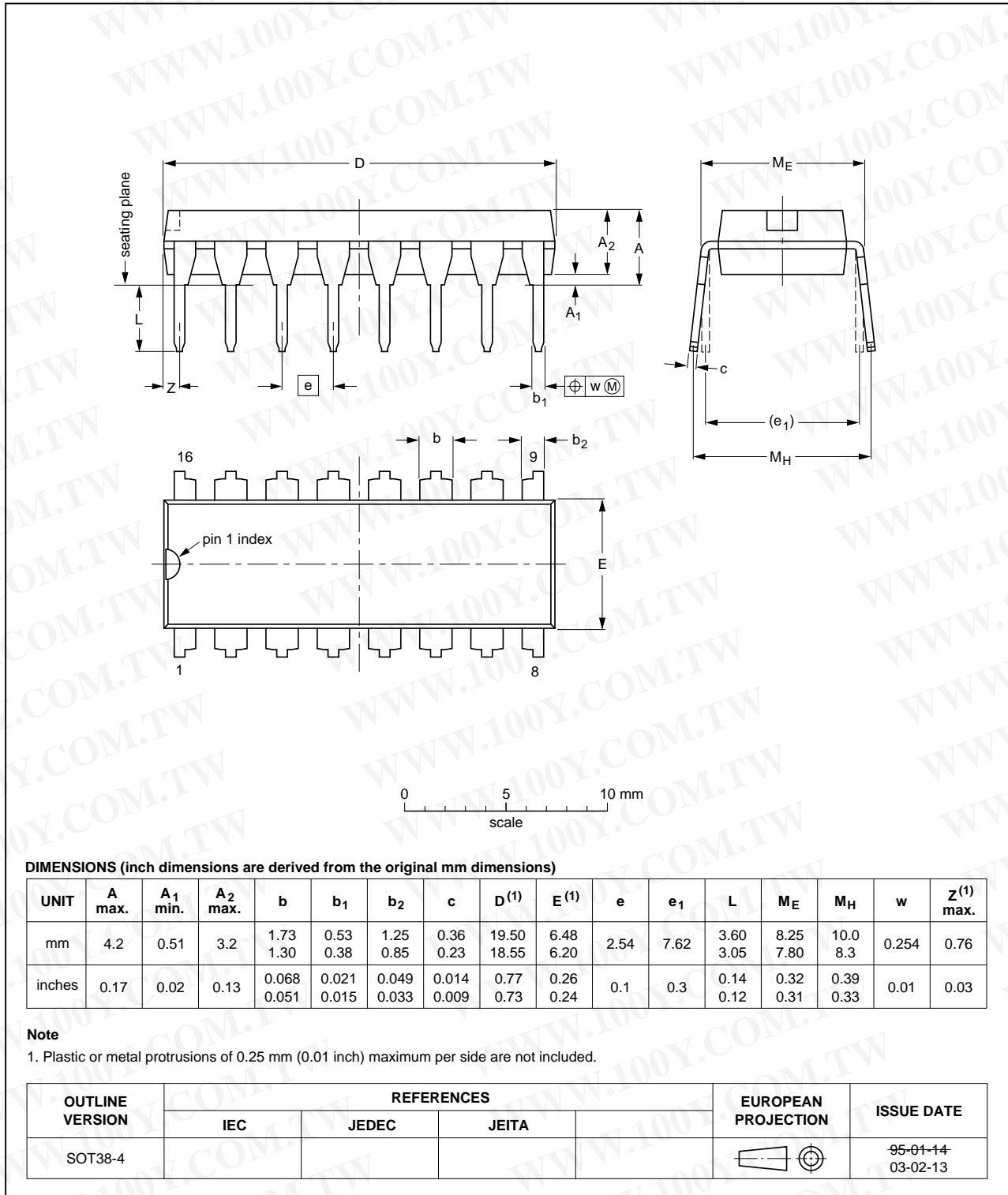

Fig 23. Package outline SOT38-4 (DIP16)

勝特力材料 886-3-5753170
 勝特力电子(上海) 86-21-34970699
 勝特力电子(深圳) 86-755-83298787
 Http://www.100y.com.tw

TSSOP16: plastic thin shrink small outline package; 16 leads; body width 4.4 mm

SOT403-1

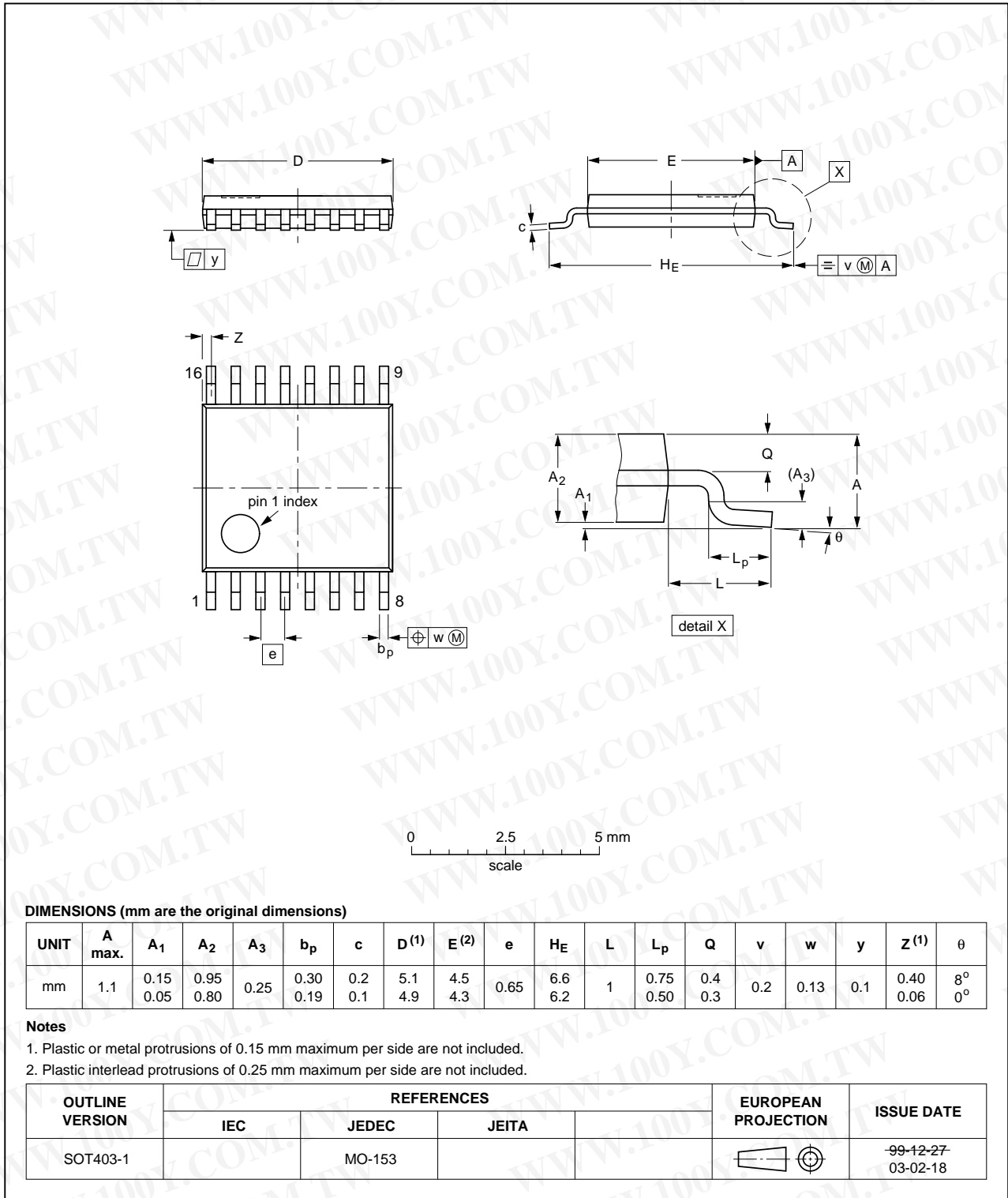

Fig 24. Package outline SOT403-1 (TSSOP16)

勝特力材料 886-3-5753170
 勝特力电子(上海) 86-21-34970699
 勝特力电子(深圳) 86-755-83298787
 Http://www.100y.com.tw

DHVQFN16: plastic dual in-line compatible thermal enhanced very thin quad flat package; no leads; 16 terminals; body 2.5 x 3.5 x 0.85 mm SOT763-1

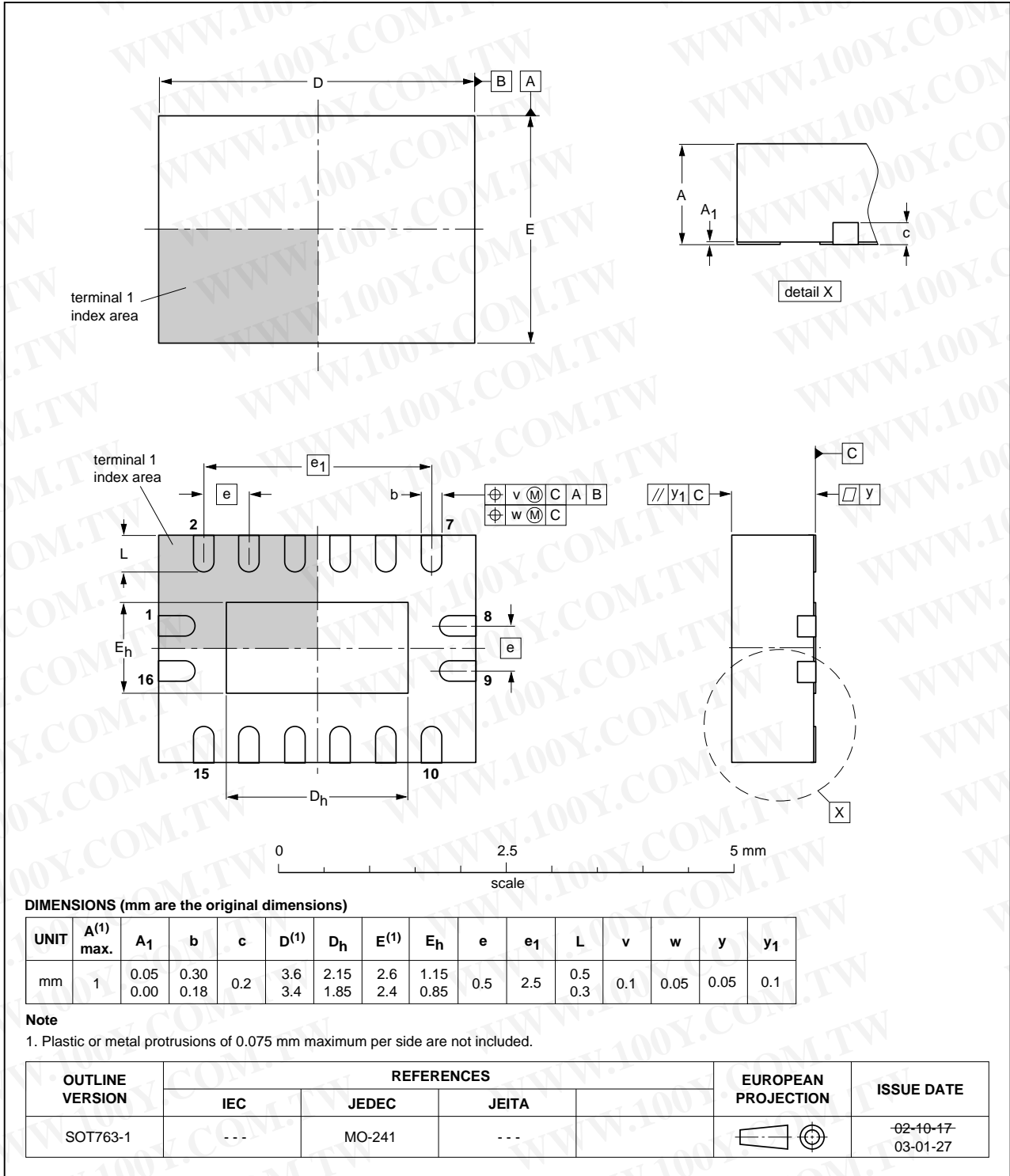

Fig 25. Package outline SOT763-1 (DHVQFN16)

14. Abbreviations

Table 13. Abbreviations

Acronym	Description
CMOS	Complementary Metal Oxide Semiconductor
DUT	Device Under Test
ESD	ElectroStatic Discharge
HBM	Human Body Model
MM	Machine Model

15. Revision history

Table 14. Revision history

Document ID	Release date	Data sheet status	Change notice	Supersedes
74HC_HCT4052 v.10	20120719	Product data sheet	-	74HC_HCT4052 v.9
Modifications:	<ul style="list-style-type: none"> • CDM added to features. 			
74HC_HCT4052 v.9	20111213	Product data sheet	-	74HC_HCT4052 v.8
Modifications:	<ul style="list-style-type: none"> • Legal pages updated. 			
74HC_HCT4052 v.8	20110511	Product data sheet	-	74HC_HCT4052 v.7
74HC_HCT4052 v.7	20110112	Product data sheet	-	74HC_HCT4052 v.6
74HC_HCT4052 v.6	20100111	Product data sheet	-	74HC_HCT4052 v.5
74HC_HCT4052 v.5	20080505	Product data sheet	-	74HC_HCT4052 v.4
74HC_HCT4052 v.4	20041111	Product specification	-	74HC_HCT4052 v.3
74HC_HCT4052 v.3	20030516	Product specification	-	74HC_HCT4052_CNV v.2
74HC_HCT4052_CNV v.2	19901201	-	-	-

勝特力材料 886-3-5753170
 勝特力电子(上海) 86-21-34970699
 勝特力电子(深圳) 86-755-83298787
[Http://www.100y.com.tw](http://www.100y.com.tw)

勝特力材料 886-3-5753170
 勝特力电子(上海) 86-21-34970699
 勝特力电子(深圳) 86-755-83298787
[Http://www.100y.com.tw](http://www.100y.com.tw)

16. Legal information

16.1 Data sheet status

Document status ^{[1][2]}	Product status ^[3]	Definition
Objective [short] data sheet	Development	This document contains data from the objective specification for product development.
Preliminary [short] data sheet	Qualification	This document contains data from the preliminary specification.
Product [short] data sheet	Production	This document contains the product specification.

[1] Please consult the most recently issued document before initiating or completing a design.

[2] The term 'short data sheet' is explained in section "Definitions".

[3] The product status of device(s) described in this document may have changed since this document was published and may differ in case of multiple devices. The latest product status information is available on the Internet at URL <http://www.nxp.com>.

16.2 Definitions

Draft — The document is a draft version only. The content is still under internal review and subject to formal approval, which may result in modifications or additions. NXP Semiconductors does not give any representations or warranties as to the accuracy or completeness of information included herein and shall have no liability for the consequences of use of such information.

Short data sheet — A short data sheet is an extract from a full data sheet with the same product type number(s) and title. A short data sheet is intended for quick reference only and should not be relied upon to contain detailed and full information. For detailed and full information see the relevant full data sheet, which is available on request via the local NXP Semiconductors sales office. In case of any inconsistency or conflict with the short data sheet, the full data sheet shall prevail.

Product specification — The information and data provided in a Product data sheet shall define the specification of the product as agreed between NXP Semiconductors and its customer, unless NXP Semiconductors and customer have explicitly agreed otherwise in writing. In no event however, shall an agreement be valid in which the NXP Semiconductors product is deemed to offer functions and qualities beyond those described in the Product data sheet.

16.3 Disclaimers

Limited warranty and liability — Information in this document is believed to be accurate and reliable. However, NXP Semiconductors does not give any representations or warranties, expressed or implied, as to the accuracy or completeness of such information and shall have no liability for the consequences of use of such information. NXP Semiconductors takes no responsibility for the content in this document if provided by an information source outside of NXP Semiconductors.

In no event shall NXP Semiconductors be liable for any indirect, incidental, punitive, special or consequential damages (including - without limitation - lost profits, lost savings, business interruption, costs related to the removal or replacement of any products or rework charges) whether or not such damages are based on tort (including negligence), warranty, breach of contract or any other legal theory.

Notwithstanding any damages that customer might incur for any reason whatsoever, NXP Semiconductors' aggregate and cumulative liability towards customer for the products described herein shall be limited in accordance with the *Terms and conditions of commercial sale* of NXP Semiconductors.

Right to make changes — NXP Semiconductors reserves the right to make changes to information published in this document, including without limitation specifications and product descriptions, at any time and without notice. This document supersedes and replaces all information supplied prior to the publication hereof.

Suitability for use — NXP Semiconductors products are not designed, authorized or warranted to be suitable for use in life support, life-critical or safety-critical systems or equipment, nor in applications where failure or malfunction of an NXP Semiconductors product can reasonably be expected to result in personal injury, death or severe property or environmental damage. NXP Semiconductors and its suppliers accept no liability for inclusion and/or use of NXP Semiconductors products in such equipment or applications and therefore such inclusion and/or use is at the customer's own risk.

Applications — Applications that are described herein for any of these products are for illustrative purposes only. NXP Semiconductors makes no representation or warranty that such applications will be suitable for the specified use without further testing or modification.

Customers are responsible for the design and operation of their applications and products using NXP Semiconductors products, and NXP Semiconductors accepts no liability for any assistance with applications or customer product design. It is customer's sole responsibility to determine whether the NXP Semiconductors product is suitable and fit for the customer's applications and products planned, as well as for the planned application and use of customer's third party customer(s). Customers should provide appropriate design and operating safeguards to minimize the risks associated with their applications and products.

NXP Semiconductors does not accept any liability related to any default, damage, costs or problem which is based on any weakness or default in the customer's applications or products, or the application or use by customer's third party customer(s). Customer is responsible for doing all necessary testing for the customer's applications and products using NXP Semiconductors products in order to avoid a default of the applications and the products or of the application or use by customer's third party customer(s). NXP does not accept any liability in this respect.

Limiting values — Stress above one or more limiting values (as defined in the Absolute Maximum Ratings System of IEC 60134) will cause permanent damage to the device. Limiting values are stress ratings only and (proper) operation of the device at these or any other conditions above those given in the Recommended operating conditions section (if present) or the Characteristics sections of this document is not warranted. Constant or repeated exposure to limiting values will permanently and irreversibly affect the quality and reliability of the device.

Terms and conditions of commercial sale — NXP Semiconductors products are sold subject to the general terms and conditions of commercial sale, as published at <http://www.nxp.com/profile/terms>, unless otherwise agreed in a valid written individual agreement. In case an individual agreement is concluded only the terms and conditions of the respective agreement shall apply. NXP Semiconductors hereby expressly objects to applying the customer's general terms and conditions with regard to the purchase of NXP Semiconductors products by customer.

No offer to sell or license — Nothing in this document may be interpreted or construed as an offer to sell products that is open for acceptance or the grant, conveyance or implication of any license under any copyrights, patents or other industrial or intellectual property rights.

Export control — This document as well as the item(s) described herein may be subject to export control regulations. Export might require a prior authorization from competent authorities.

Non-automotive qualified products — Unless this data sheet expressly states that this specific NXP Semiconductors product is automotive qualified, the product is not suitable for automotive use. It is neither qualified nor tested in accordance with automotive testing or application requirements. NXP Semiconductors accepts no liability for inclusion and/or use of non-automotive qualified products in automotive equipment or applications.

In the event that customer uses the product for design-in and use in automotive applications to automotive specifications and standards, customer (a) shall use the product without NXP Semiconductors' warranty of the product for such automotive applications, use and specifications, and (b) whenever customer uses the product for automotive applications beyond

NXP Semiconductors' specifications such use shall be solely at customer's own risk, and (c) customer fully indemnifies NXP Semiconductors for any liability, damages or failed product claims resulting from customer design and use of the product for automotive applications beyond NXP Semiconductors' standard warranty and NXP Semiconductors' product specifications.

Translations — A non-English (translated) version of a document is for reference only. The English version shall prevail in case of any discrepancy between the translated and English versions.

16.4 Trademarks

Notice: All referenced brands, product names, service names and trademarks are the property of their respective owners.

17. Contact information

For more information, please visit: <http://www.nxp.com>

For sales office addresses, please send an email to: salesaddresses@nxp.com

勝特力材料 886-3-5753170
勝特力电子(上海) 86-21-34970699
勝特力电子(深圳) 86-755-83298787
[Http://www.100y.com.tw](http://www.100y.com.tw)

18. Contents

1	General description	1
2	Features and benefits	1
3	Applications	2
4	Ordering information	2
5	Functional diagram	3
6	Pinning information	5
6.1	Pinning	5
6.2	Pin description	5
7	Functional description	6
7.1	Function table	6
8	Limiting values	6
9	Recommended operating conditions	7
10	Static characteristics	8
11	Dynamic characteristics	13
12	Additional dynamic characteristics	17
13	Package outline	21
14	Abbreviations	26
15	Revision history	26
16	Legal information	27
16.1	Data sheet status	27
16.2	Definitions	27
16.3	Disclaimers	27
16.4	Trademarks	28
17	Contact information	28
18	Contents	29

勝特力材料 886-3-5753170
 勝特力电子(上海) 86-21-34970699
 勝特力电子(深圳) 86-755-83298787
[Http://www.100y.com.tw](http://www.100y.com.tw)

Please be aware that important notices concerning this document and the product(s) described herein, have been included in section 'Legal information'.

© NXP B.V. 2012. All rights reserved.

For more information, please visit: <http://www.nxp.com>
 For sales office addresses, please send an email to: salesaddresses@nxp.com

Date of release: 19 July 2012
 Document identifier: 74HC_HCT4052