

74HC244; 74HCT244

Octal buffer/line driver; 3-state

Rev. 03 — 22 December 2005

Product data sheet

1. General description

The 74HC244; 74HCT244 is a high-speed Si-gate CMOS device and is pin compatible with Low-power Schottky TTL (LSTTL).

The 74HC244; 74HCT244 has octal non-inverting buffer/line drivers with 3-state outputs. The 3-state outputs are controlled by the output enable inputs $\overline{1OE}$ and $\overline{2OE}$. A HIGH on \overline{nOE} causes the outputs to assume a high-impedance OFF-state. The 74HC244; 74HCT244 is identical to the 74HC240; 74HCT240 but has non-inverting outputs.

2. Features

- Octal bus interface
- Non-inverting 3-state outputs
- Complies with JEDEC standard no. 7A
- ESD protection:
 - ◆ HBM EIA/JESD22-A114-C exceeds 2000 V
 - ◆ MM EIA/JESD22-A115-A exceeds 200 V
- Multiple package options
- Specified from $-40\text{ }^{\circ}\text{C}$ to $+85\text{ }^{\circ}\text{C}$ and from $-40\text{ }^{\circ}\text{C}$ to $+125\text{ }^{\circ}\text{C}$

3. Quick reference data

Table 1: Quick reference data

$GND = 0\text{ V}$; $T_{amb} = 25\text{ }^{\circ}\text{C}$; $t_r = t_f = 6\text{ ns}$

Symbol	Parameter	Conditions	Min	Typ	Max	Unit
74HC244						
t_{PHL} , t_{PLH}	propagation delay nAn to nYn	$V_{CC} = 5\text{ V}$; $C_L = 15\text{ pF}$	-	9	-	ns
C_i	input capacitance		-	3.5	-	pF
C_{PD}	power dissipation capacitance	per buffer; $V_I = GND$ to V_{CC}	[1]	35	-	pF
74HCT244						
t_{PHL} , t_{PLH}	propagation delay nAn to nYn	$V_{CC} = 5\text{ V}$; $C_L = 15\text{ pF}$	-	11	-	ns
C_i	input capacitance		-	3.5	-	pF
C_{PD}	power dissipation capacitance	per buffer; $V_I = GND$ to ($V_{CC} - 1.5\text{ V}$)	[1]	35	-	pF

[1] C_{PD} is used to determine the dynamic power dissipation (P_D in μW):

$$P_D = C_{PD} \times V_{CC}^2 \times f_i \times N + \sum(C_L \times V_{CC}^2 \times f_o) \text{ where:}$$

勝特力材料 886-3-5753170
勝特力电子(上海) 86-21-34970699
勝特力电子(深圳) 86-755-83298787
[Http://www.100y.com.tw](http://www.100y.com.tw)

PHILIPS

f_i = input frequency in MHz;
 f_o = output frequency in MHz;
 C_L = output load capacitance in pF;
 V_{CC} = supply voltage in V;
 N = number of inputs switching;
 $\Sigma(C_L \times V_{CC}^2 \times f_o)$ = sum of outputs.

4. Ordering information

Table 2: Ordering information

Type number	Package			
	Temperature range	Name	Description	Version
74HC244				
74HC244N	-40 °C to +125 °C	DIP20	plastic dual in-line package; 20 leads (300 mil)	SOT146-1
74HC244D	-40 °C to +125 °C	SO20	plastic small outline package; 20 leads; body width 7.5 mm	SOT163-1
74HC244DB	-40 °C to +125 °C	SSOP20	plastic shrink small outline package; 20 leads; body width 5.3 mm	SOT339-1
74HC244PW	-40 °C to +125 °C	TSSOP20	plastic thin shrink small outline package; 20 leads; body width 4.4 mm	SOT360-1
74HC244BQ	-40 °C to +125 °C	DHVQFN20	plastic dual in-line compatible thermal enhanced very thin quad flat package; no leads; 20 terminals; body 2.5 × 4.5 × 0.85 mm	SOT764-1
74HCT244				
74HCT244N	-40 °C to +125 °C	DIP20	plastic dual in-line package; 20 leads (300 mil)	SOT146-1
74HCT244D	-40 °C to +125 °C	SO20	plastic small outline package; 20 leads; body width 7.5 mm	SOT163-1
74HCT244DB	-40 °C to +125 °C	SSOP20	plastic shrink small outline package; 20 leads; body width 5.3 mm	SOT339-1
74HCT244PW	-40 °C to +125 °C	TSSOP20	plastic thin shrink small outline package; 20 leads; body width 4.4 mm	SOT360-1
74HCT244BQ	-40 °C to +125 °C	DHVQFN20	plastic dual in-line compatible thermal enhanced very thin quad flat package; no leads; 20 terminals; body 2.5 × 4.5 × 0.85 mm	SOT764-1

5. Functional diagram

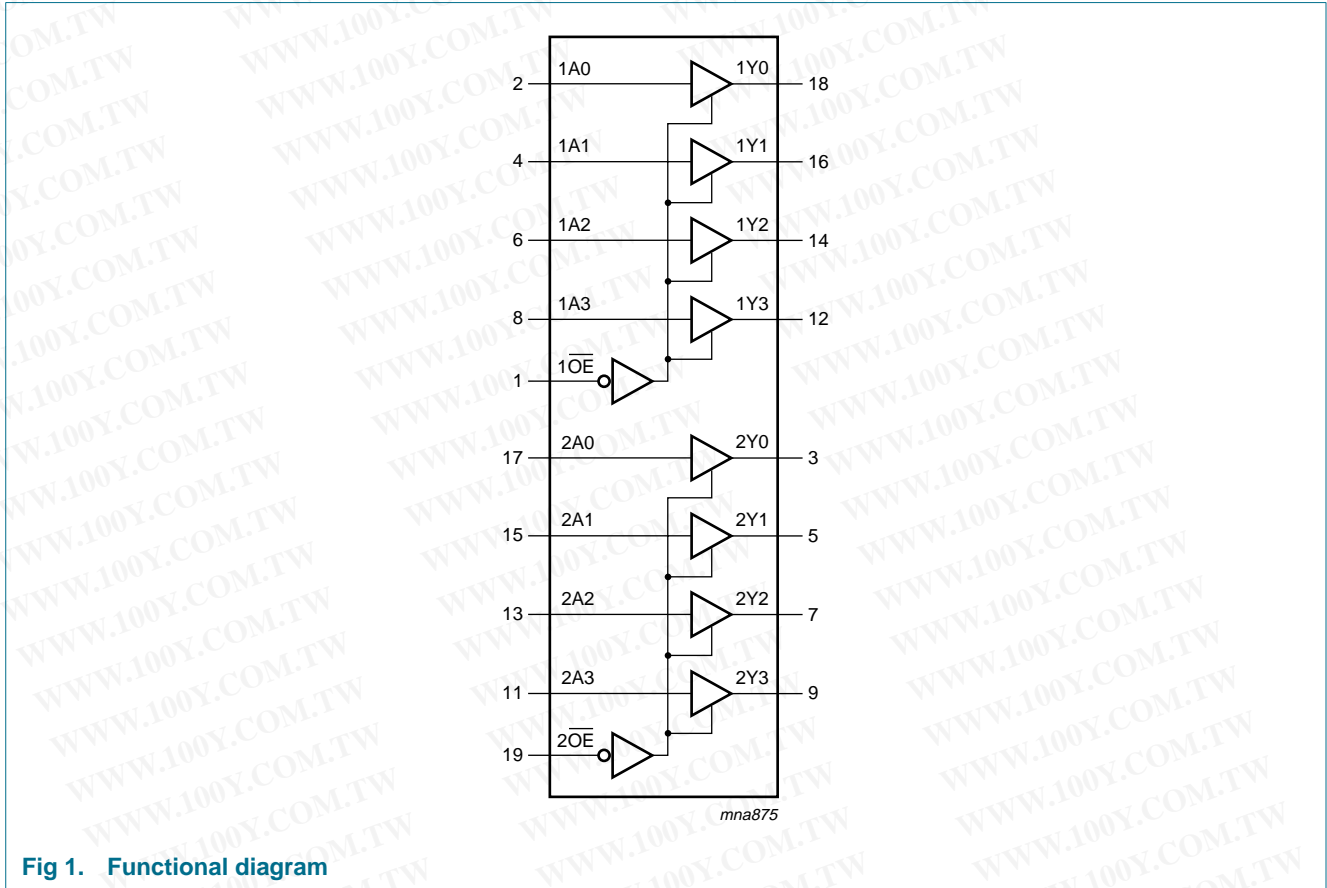

Fig 1. Functional diagram

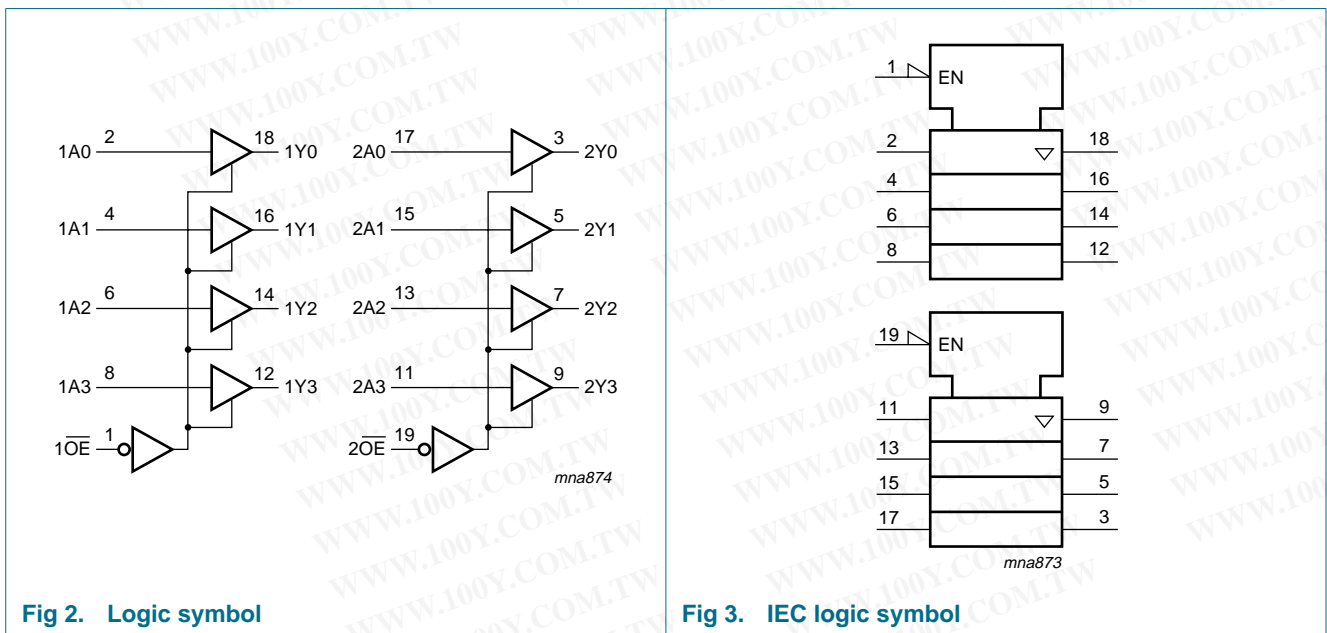
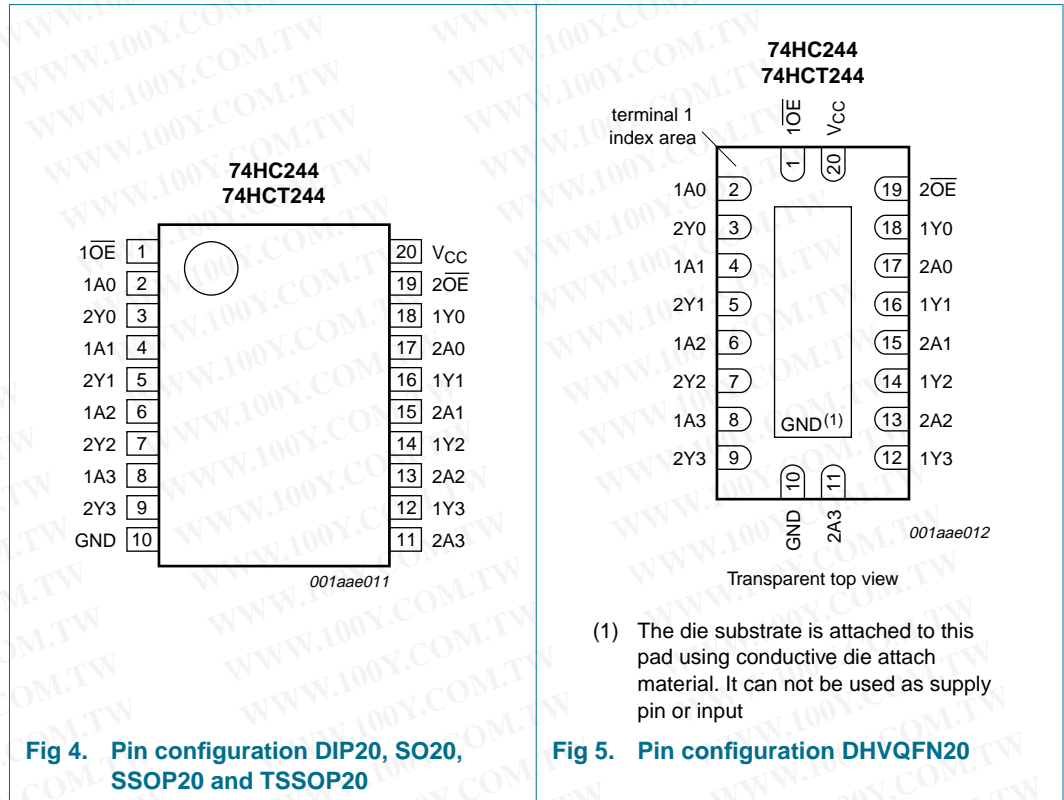

Fig 2. Logic symbol

Fig 3. IEC logic symbol

6. Pinning information

6.1 Pinning



6.2 Pin description

Table 3: Pin description

Symbol	Pin	Description
1OE	1	1 output enable input (active LOW)
1A0	2	1 data input 0
2Y0	3	2 bus output 0
1A1	4	1 data input 1
2Y1	5	2 bus output 1
1A2	6	1 data input 2
2Y2	7	2 bus output 2
1A3	8	1 data input 3
2Y3	9	2 bus output 3
GND	10	ground (0 V)
2A3	11	2 data input 3
1Y3	12	1 bus output 3
2A2	13	2 data input 2
1Y2	14	1 bus output 2

Table 3: Pin description ...continued

Symbol	Pin	Description
2A1	15	2 data input 1
1Y1	16	1 bus output 1
2A0	17	2 data input 0
1Y0	18	1 bus output 0
$\overline{2OE}$	19	2 output enable input (active LOW)
V _{CC}	20	supply voltage

7. Functional description

7.1 Function table

Table 4: Function table [1]

Control	Input	Output
nOE	nAn	nYn
L	L	L
	H	H
H	X	Z

- [1] H = HIGH voltage level;
 L = LOW voltage level;
 X = don't care;
 Z = high-impedance OFF-state.

8. Limiting values

Table 5: Limiting values

In accordance with the Absolute Maximum Rating System (IEC 60134). Voltages are referenced to GND (ground = 0 V).

Symbol	Parameter	Conditions	Min	Max	Unit
V _{CC}	supply voltage		-0.5	+7	V
I _{IK}	input clamping current	V _I < -0.5 V or V _I > V _{CC} + 0.5 V	-	±20	mA
I _{OK}	output clamping current	V _O < -0.5 V or V _O > V _{CC} + 0.5 V	-	±20	mA
I _O	output current	V _O = -0.5 V to (V _{CC} + 0.5 V)	-	±35	mA
I _{CC}	quiescent supply current		-	70	mA
I _{GND}	ground current		-	-70	mA
T _{stg}	storage temperature		-65	+150	°C
P _{tot}	total power dissipation				
	DIP20 package		[1]	-	750 mW
	SO20 package		[2]	-	500 mW
	SSOP20 package		[3]	-	500 mW
	TSSOP20 package		[3]	-	500 mW
	DHVQFN20 package		[4]	-	500 mW

- [1] For DIP20 package: P_{tot} derates linearly with 12 mW/K above 70 °C.
- [2] For SO20 package: P_{tot} derates linearly with 8 mW/K above 70 °C.
- [3] For SSOP20 and TSSOP20 packages: P_{tot} derates linearly with 5.5 mW/K above 60 °C
- [4] For DHVQFN20 packages: P_{tot} derates linearly with 4.5 mW/K above 60 °C.

9. Recommended operating conditions

Table 6: Recommended operating conditions

Symbol	Parameter	Conditions	Min	Typ	Max	Unit
74HC244						
V_{CC}	supply voltage		2.0	5.0	6.0	V
V_I	input voltage		0	-	V_{CC}	V
V_O	output voltage		0	-	V_{CC}	V
T_{amb}	ambient temperature		-40	25	+125	°C
t_r, t_f	input rise and fall time	$V_{CC} = 2.0\text{ V}$	-	-	1000	ns
		$V_{CC} = 4.5\text{ V}$	-	6.0	500	ns
		$V_{CC} = 6.0\text{ V}$	-	-	400	ns
74HCT244						
V_{CC}	supply voltage		4.5	5.0	5.5	V
V_I	input voltage		0	-	V_{CC}	V
V_O	output voltage		0	-	V_{CC}	V
T_{amb}	ambient temperature		-40	25	+125	°C
t_r, t_f	input rise and fall time	$V_{CC} = 4.5\text{ V}$	-	6.0	500	ns

10. Static characteristics

Table 7: Static characteristics 74HC244

At recommended operating conditions; voltages are referenced to GND (ground = 0V).

Symbol	Parameter	Conditions	Min	Typ	Max	Unit
$T_{amb} = 25\text{ °C}$						
V_{IH}	HIGH-state input voltage	$V_{CC} = 2.0\text{ V}$	1.5	1.2	-	V
		$V_{CC} = 4.5\text{ V}$	3.15	2.4	-	V
		$V_{CC} = 6.0\text{ V}$	4.2	3.2	-	V
V_{IL}	LOW-state input voltage	$V_{CC} = 2.0\text{ V}$	-	0.8	0.5	V
		$V_{CC} = 4.5\text{ V}$	-	2.1	1.35	V
		$V_{CC} = 6.0\text{ V}$	-	2.8	1.8	V
V_{OH}	HIGH-state output voltage	$V_I = V_{IH}$ or V_{IL}	-	-	-	
		$I_O = -20\text{ }\mu\text{A}; V_{CC} = 2.0\text{ V}$	1.9	2.0	-	V
		$I_O = -20\text{ }\mu\text{A}; V_{CC} = 4.5\text{ V}$	4.4	4.5	-	V
		$I_O = -20\text{ }\mu\text{A}; V_{CC} = 6.0\text{ V}$	5.9	6.0	-	V
		$I_O = -6.0\text{ mA}; V_{CC} = 4.5\text{ V}$	3.98	4.32	-	V
		$I_O = -7.8\text{ mA}; V_{CC} = 6\text{ V}$	5.48	5.81	-	V

Table 7: Static characteristics 74HC244 ...continued

At recommended operating conditions; voltages are referenced to GND (ground = 0V).

Symbol	Parameter	Conditions	Min	Typ	Max	Unit
V _{OL}	LOW-state output voltage	V _I = V _{IH} or V _{IL}				
		I _O = 20 μA; V _{CC} = 2.0 V	-	0	0.1	V
		I _O = 20 μA; V _{CC} = 4.5 V	-	0	0.1	V
		I _O = 20 μA; V _{CC} = 6.0 V	-	0	0.1	V
		I _O = 6.0 mA; V _{CC} = 4.5 V	-	0.15	0.26	V
		I _O = 7.8 mA; V _{CC} = 6 V	-	0.16	0.26	V
I _{LI}	input leakage current	V _I = V _{CC} or GND; V _{CC} = 6 V	-	-	±0.1	μA
I _{OZ}	OFF-state output current	V _I = V _{IH} or V _{IL} ; V _O = V _{CC} or GND	-	-	±0.5	μA
I _{CC}	quiescent supply current	V _I = V _{CC} or GND; I _O = 0 A; V _{CC} = 6.0 V	-	-	8.0	μA
C _i	input capacitance		-	3.5	-	pF
T_{amb} = -40 °C to +85 °C						
V _{IH}	HIGH-state input voltage	V _{CC} = 2.0 V	1.5	-	-	V
		V _{CC} = 4.5 V	3.15	-	-	V
		V _{CC} = 6.0 V	4.2	-	-	V
V _{IL}	LOW-state input voltage	V _{CC} = 2.0 V	-	-	0.5	V
		V _{CC} = 4.5 V	-	-	1.35	V
		V _{CC} = 6.0 V	-	-	1.8	V
V _{OH}	HIGH-state output voltage	V _I = V _{IH} or V _{IL}				
		I _O = -20 μA; V _{CC} = 2.0 V	1.9	-	-	V
		I _O = -20 μA; V _{CC} = 4.5 V	4.4	-	-	V
		I _O = -20 μA; V _{CC} = 6.0 V	5.9	-	-	V
		I _O = -6.0 mA; V _{CC} = 4.5 V	3.84	-	-	V
		I _O = -7.8 mA; V _{CC} = 6 V	5.34	-	-	V
V _{OL}	LOW-state output voltage	V _I = V _{IH} or V _{IL}				
		I _O = 20 μA; V _{CC} = 2.0 V	-	-	0.1	V
		I _O = 20 μA; V _{CC} = 4.5 V	-	-	0.1	V
		I _O = 20 μA; V _{CC} = 6.0 V	-	-	0.1	V
		I _O = 6.0 mA; V _{CC} = 4.5 V	-	-	0.33	V
		I _O = 7.8 mA; V _{CC} = 6 V	-	-	0.33	V
I _{LI}	input leakage current	V _I = V _{CC} or GND; V _{CC} = 6 V	-	-	±1.0	μA
I _{OZ}	OFF-state output current	V _I = V _{IH} or V _{IL} ; V _O = V _{CC} or GND	-	-	±5.0	μA
I _{CC}	quiescent supply current	V _I = V _{CC} or GND; I _O = 0 A; V _{CC} = 6.0 V	-	-	80	μA

Table 7: Static characteristics 74HC244 ...continued

At recommended operating conditions; voltages are referenced to GND (ground = 0V).

Symbol	Parameter	Conditions	Min	Typ	Max	Unit
T_{amb} = -40 °C to +125 °C						
V _{IH}	HIGH-state input voltage	V _{CC} = 2.0 V	1.5	-	-	V
		V _{CC} = 4.5 V	3.15	-	-	V
		V _{CC} = 6.0 V	4.2	-	-	V
V _{IL}	LOW-state input voltage	V _{CC} = 2.0 V	-	-	0.5	V
		V _{CC} = 4.5 V	-	-	1.35	V
		V _{CC} = 6.0 V	-	-	1.8	V
V _{OH}	HIGH-state output voltage	V _I = V _{IH} or V _{IL}				
		I _O = -20 μA; V _{CC} = 2.0 V	1.9	-	-	V
		I _O = -20 μA; V _{CC} = 4.5 V	4.4	-	-	V
		I _O = -20 μA; V _{CC} = 6.0 V	5.9	-	-	V
		I _O = -6.0 mA; V _{CC} = 4.5 V	3.7	-	-	V
		I _O = -7.8 mA; V _{CC} = 6 V	5.2	-	-	V
V _{OL}	LOW-state output voltage	V _I = V _{IH} or V _{IL}				
		I _O = 20 μA; V _{CC} = 2.0 V	-	-	0.1	V
		I _O = 20 μA; V _{CC} = 4.5 V	-	-	0.1	V
		I _O = 20 μA; V _{CC} = 6.0 V	-	-	0.1	V
		I _O = 6.0 mA; V _{CC} = 4.5 V	-	-	0.4	V
		I _O = 7.8 mA; V _{CC} = 6 V	-	-	0.4	V
I _{LI}	input leakage current	V _I = V _{CC} or GND; V _{CC} = 6 V	-	-	±1.0	μA
I _{OZ}	OFF-state output current	V _I = V _{IH} or V _{IL} ; V _O = V _{CC} or GND	-	-	±10.0	μA
I _{CC}	quiescent supply current	V _I = V _{CC} or GND; I _O = 0 A; V _{CC} = 6.0 V	-	-	160	μA

Table 8: Static characteristics 74HCT244

At recommended operating conditions; voltages are referenced to GND (ground = 0 V).

Symbol	Parameter	Conditions	Min	Typ	Max	Unit
T_{amb} = 25 °C						
V _{IH}	HIGH-state input voltage	V _{CC} = 4.5 V to 5.5 V	2.0	1.6	-	V
V _{IL}	LOW-state input voltage	V _{CC} = 4.5 V to 5.5 V	-	1.2	0.8	V
V _{OH}	HIGH-state output voltage	V _I = V _{IH} or V _{IL} ; V _{CC} = 4.5 V				
		I _O = -20 μA	4.4	4.5	-	V
		I _O = -6.0 mA	3.98	4.32	-	V
V _{OL}	LOW-state output voltage	V _I = V _{IH} or V _{IL} ; V _{CC} = 4.5 V				
		I _O = 20 μA	-	0	0.1	V
		I _O = 6.0 mA	-	0.16	0.26	V
I _{LI}	input leakage current	V _I = V _{CC} or GND; V _{CC} = 5.5 V	-	-	±0.1	μA
I _{OZ}	OFF-state output current	per input pin; V _I = V _{IH} or V _{IL} ; V _O = V _{CC} or GND; other pins at GND or V _{CC} ; I _O = 0 A; V _{CC} = 5.5 V	-	-	±0.5	μA
I _{CC}	quiescent supply current	V _I = V _{CC} or GND; I _O = 0 A; V _{CC} = 5.5 V	-	-	8.0	μA

Table 8: Static characteristics 74HCT244 ...continued

At recommended operating conditions; voltages are referenced to GND (ground = 0 V).

Symbol	Parameter	Conditions	Min	Typ	Max	Unit
ΔI_{CC}	additional quiescent supply current	per input pin; $V_I = V_{CC} - 2.1$ V; other inputs at V_{CC} or GND; $I_O = 0$ A; $V_{CC} = 4.5$ V to 5.5 V		70	252	μ A
C_i	input capacitance		-	3.5	-	pF
$T_{amb} = -40$ °C to $+85$ °C						
V_{IH}	HIGH-state input voltage	$V_{CC} = 4.5$ V to 5.5 V	2.0	-	-	V
V_{IL}	LOW-state input voltage	$V_{CC} = 4.5$ V to 5.5 V	-	-	0.8	V
V_{OH}	HIGH-state output voltage	$V_I = V_{IH}$ or V_{IL} ; $V_{CC} = 4.5$ V				
		$I_O = -20$ μ A	4.4	-	-	V
		$I_O = -6.0$ mA	3.84	-	-	V
V_{OL}	LOW-state output voltage	$V_I = V_{IH}$ or V_{IL} ; $V_{CC} = 4.5$ V				
		$I_O = 20$ μ A	-	-	0.1	V
		$I_O = 6.0$ mA	-	-	0.33	V
I_{LI}	input leakage current	$V_I = V_{CC}$ or GND; $V_{CC} = 5.5$ V	-	-	± 1.0	μ A
I_{OZ}	OFF-state output current	per input pin; $V_I = V_{IH}$ or V_{IL} ; $V_O = V_{CC}$ or GND; other pins at GND or V_{CC} ; $I_O = 0$ A; $V_{CC} = 5.5$ V			± 5.0	μ A
I_{CC}	quiescent supply current	$V_I = V_{CC}$ or GND; $I_O = 0$ A; $V_{CC} = 5.5$ V	-	-	80	μ A
ΔI_{CC}	additional quiescent supply current	per input pin; $V_I = V_{CC} - 2.1$ V; other inputs at V_{CC} or GND; $I_O = 0$ A; $V_{CC} = 4.5$ V to 5.5 V	-	-	315	μ A
$T_{amb} = -40$ °C to $+125$ °C						
V_{IH}	HIGH-state input voltage	$V_{CC} = 4.5$ V to 5.5 V	2.0	-	-	V
V_{IL}	LOW-state input voltage	$V_{CC} = 4.5$ V to 5.5 V	-	-	0.8	V
V_{OH}	HIGH-state output voltage	$V_I = V_{IH}$ or V_{IL} ; $V_{CC} = 4.5$ V				
		$I_O = -20$ μ A	4.4	-	-	V
		$I_O = -6.0$ mA	3.7	-	-	V
V_{OL}	LOW-state output voltage	$V_I = V_{IH}$ or V_{IL} ; $V_{CC} = 4.5$ V				
		$I_O = 20$ μ A	-	-	0.1	V
		$I_O = 6.0$ mA	-	-	0.4	V
I_{LI}	input leakage current	$V_I = V_{CC}$ or GND; $V_{CC} = 5.5$ V	-	-	± 1.0	μ A
I_{OZ}	OFF-state output current	per input pin; $V_I = V_{IH}$ or V_{IL} ; $V_O = V_{CC}$ or GND; other pins at GND or V_{CC} ; $I_O = 0$ A; $V_{CC} = 5.5$ V	-	-	± 10.0	μ A
I_{CC}	quiescent supply current	$V_I = V_{CC}$ or GND; $I_O = 0$ A; $V_{CC} = 5.5$ V	-	-	160	μ A
ΔI_{CC}	additional quiescent supply current	per input pin; $V_I = V_{CC} - 2.1$ V; other inputs at V_{CC} or GND; $I_O = 0$ A; $V_{CC} = 4.5$ V to 5.5 V	-	-	343	μ A

11. Dynamic characteristics

Table 9: Dynamic characteristics 74HC244
GND = 0 V; $t_r = t_f = 6$ ns; $C_L = 50$ pF unless otherwise specified; for test circuit see [Figure 8](#).

Symbol	Parameter	Conditions	Min	Typ	Max	Unit
$T_{amb} = 25$ °C						
t_{PHL} , t_{PLH}	propagation delay nAn to nYn	see Figure 6				
		$V_{CC} = 2.0$ V	-	30	110	ns
		$V_{CC} = 4.5$ V	-	11	22	ns
		$V_{CC} = 5$ V; $C_L = 15$ pF	-	9	-	ns
		$V_{CC} = 6.0$ V	-	9	19	ns
t_{PZH} , t_{PZL}	3-state output enable time nOE to nYn	see Figure 7				
		$V_{CC} = 2.0$ V	-	36	150	ns
		$V_{CC} = 4.5$ V	-	13	30	ns
		$V_{CC} = 6.0$ V	-	10	26	ns
t_{PHZ} , t_{PLZ}	3-state output disable time nOE to nYn	see Figure 7				
		$V_{CC} = 2.0$ V	-	39	150	ns
		$V_{CC} = 4.5$ V	-	14	30	ns
		$V_{CC} = 6.0$ V	-	11	26	ns
t_{THL} , t_{TLH}	output transition time	see Figure 6				
		$V_{CC} = 2.0$ V	-	14	60	ns
		$V_{CC} = 4.5$ V	-	5	12	ns
		$V_{CC} = 6.0$ V	-	4	10	ns
C_{PD}	power dissipation capacitance	$V_I = GND$ to V_{CC}	[1] -	35	-	pF
$T_{amb} = -40$ °C to $+85$ °C						
t_{PHL} , t_{PLH}	propagation delay nAn to nYn	see Figure 6				
		$V_{CC} = 2.0$ V	-	-	145	ns
		$V_{CC} = 4.5$ V	-	-	28	ns
		$V_{CC} = 6.0$ V	-	-	24	ns
t_{PZH} , t_{PZL}	3-state output enable time nOE to nYn	see Figure 7				
		$V_{CC} = 2.0$ V	-	-	190	ns
		$V_{CC} = 4.5$ V	-	-	38	ns
		$V_{CC} = 6.0$ V	-	-	33	ns
t_{PHZ} , t_{PLZ}	3-state output disable time nOE to nYn	see Figure 7				
		$V_{CC} = 2.0$ V	-	-	190	ns
		$V_{CC} = 4.5$ V	-	-	38	ns
		$V_{CC} = 6.0$ V	-	-	33	ns
t_{THL} , t_{TLH}	output transition time	see Figure 6				
		$V_{CC} = 2.0$ V	-	-	75	ns
		$V_{CC} = 4.5$ V	-	-	15	ns
		$V_{CC} = 6.0$ V	-	-	13	ns

Table 9: Dynamic characteristics 74HC244 ...continued

$GND = 0\text{ V}$; $t_r = t_f = 6\text{ ns}$; $C_L = 50\text{ pF}$ unless otherwise specified; for test circuit see [Figure 8](#).

Symbol	Parameter	Conditions	Min	Typ	Max	Unit
$T_{amb} = -40\text{ °C to }+125\text{ °C}$						
t_{PHL} , t_{PLH}	propagation delay nAn to nYn	see Figure 6				
		$V_{CC} = 2.0\text{ V}$	-	-	165	ns
		$V_{CC} = 4.5\text{ V}$	-	-	33	ns
		$V_{CC} = 6.0\text{ V}$	-	-	28	ns
t_{PZH} , t_{PZL}	3-state output enable time nOE to nYn	see Figure 7				
		$V_{CC} = 2.0\text{ V}$	-	-	225	ns
		$V_{CC} = 4.5\text{ V}$	-	-	45	ns
		$V_{CC} = 6.0\text{ V}$	-	-	38	ns
t_{PHZ} , t_{PLZ}	3-state output disable time nOE to nYn	see Figure 7				
		$V_{CC} = 2.0\text{ V}$	-	-	225	ns
		$V_{CC} = 4.5\text{ V}$	-	-	45	ns
		$V_{CC} = 6.0\text{ V}$	-	-	38	ns
t_{THL} , t_{TLH}	output transition time	see Figure 6				
		$V_{CC} = 2.0\text{ V}$	-	-	90	ns
		$V_{CC} = 4.5\text{ V}$	-	-	18	ns
		$V_{CC} = 6.0\text{ V}$	-	-	15	ns

[1] C_{PD} is used to determine the dynamic power dissipation (P_D in μW):

$$P_D = C_{PD} \times V_{CC}^2 \times f_i \times N + \sum(C_L \times V_{CC}^2 \times f_o) \text{ where:}$$

f_i = input frequency in MHz;

f_o = output frequency in MHz;

C_L = output load capacitance in pF;

V_{CC} = supply voltage in V;

N = number of inputs switching;

$\sum(C_L \times V_{CC}^2 \times f_o)$ = sum of outputs.

Table 10: Dynamic characteristics type 74HCT244

$GND = 0\text{ V}$; $t_r = t_f = 6\text{ ns}$; $C_L = 50\text{ pF}$ unless otherwise specified; for test circuit see [Figure 8](#).

Symbol	Parameter	Conditions	Min	Typ	Max	Unit
$T_{amb} = 25\text{ °C}$						
t_{PHL} , t_{PLH}	propagation delay nAn to nYn	see Figure 6				
		$V_{CC} = 4.5\text{ V}$	-	13	22	ns
		$V_{CC} = 5\text{ V}$; $C_L = 15\text{ pF}$	-	11	-	ns
t_{PZH} , t_{PZL}	3-state output enable time nOE to nYn	$V_{CC} = 4.5\text{ V}$; see Figure 7	-	15	30	ns
t_{PHZ} , t_{PLZ}	3-state output disable time nOE to nYn	$V_{CC} = 4.5\text{ V}$; see Figure 7	-	15	25	ns
t_{THL} , t_{TLH}	output transition time	$V_{CC} = 4.5\text{ V}$; see Figure 6	-	5	12	ns
C_{PD}	power dissipation capacitance	$V_I = GND$ to $(V_{CC} - 1.5\text{ V})$	[1]	-	35	pF

Table 10: Dynamic characteristics type 74HCT244 ...continued

$GND = 0\text{ V}$; $t_r = t_f = 6\text{ ns}$; $C_L = 50\text{ pF}$ unless otherwise specified; for test circuit see [Figure 8](#).

Symbol	Parameter	Conditions	Min	Typ	Max	Unit
$T_{amb} = -40\text{ °C to }+85\text{ °C}$						
t_{PHL} , t_{PLH}	propagation delay nAn to nYn	$V_{CC} = 4.5\text{ V}$; see Figure 6	-	-	28	ns
t_{PZH} , t_{PZL}	3-state output enable time nOE to nYn	$V_{CC} = 4.5\text{ V}$; see Figure 7	-	-	38	ns
t_{PHZ} , t_{PLZ}	3-state output disable time nOE to nYn	$V_{CC} = 4.5\text{ V}$; see Figure 7	-	-	31	ns
t_{THL} , t_{TLH}	output transition time	$V_{CC} = 4.5\text{ V}$; see Figure 6	-	-	15	ns
$T_{amb} = -40\text{ °C to }+125\text{ °C}$						
t_{PHL} , t_{PLH}	propagation delay nAn to nYn	$V_{CC} = 4.5\text{ V}$; see Figure 6	-	-	33	ns
t_{PZH} , t_{PZL}	3-state output enable time nOE to nYn	$V_{CC} = 4.5\text{ V}$; see Figure 7	-	-	45	ns
t_{PHZ} , t_{PLZ}	3-state output disable time nOE to nYn	$V_{CC} = 4.5\text{ V}$; see Figure 7	-	-	38	ns
t_{THL} , t_{TLH}	output transition time	$V_{CC} = 4.5\text{ V}$; see Figure 6	-	-	18	ns

[1] C_{PD} is used to determine the dynamic power dissipation (P_D in μW):

$$P_D = C_{PD} \times V_{CC}^2 \times f_i \times N + \sum(C_L \times V_{CC}^2 \times f_o) \text{ where:}$$

f_i = input frequency in MHz;

f_o = output frequency in MHz;

C_L = output load capacitance in pF;

V_{CC} = supply voltage in V;

N = number of inputs switching;

$\sum(C_L \times V_{CC}^2 \times f_o)$ = sum of outputs.

12. Waveforms

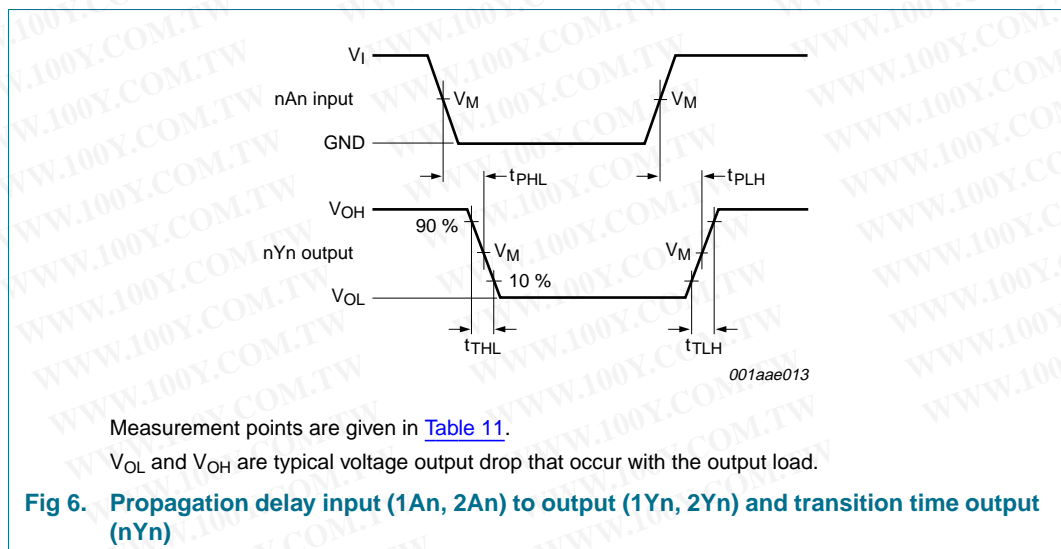

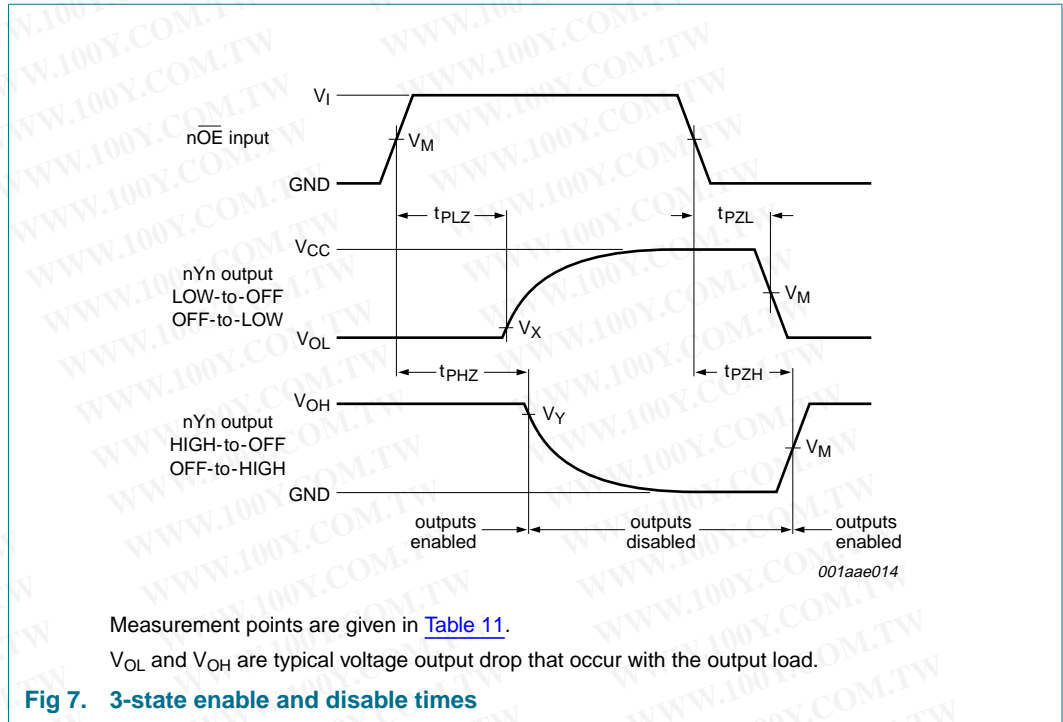

Table 11: Measurement points

Type	Input	Output
	V_M	V_M
74HC244	$0.5V_{CC}$	$0.5V_{CC}$
74HCT244	1.3 V	1.3 V

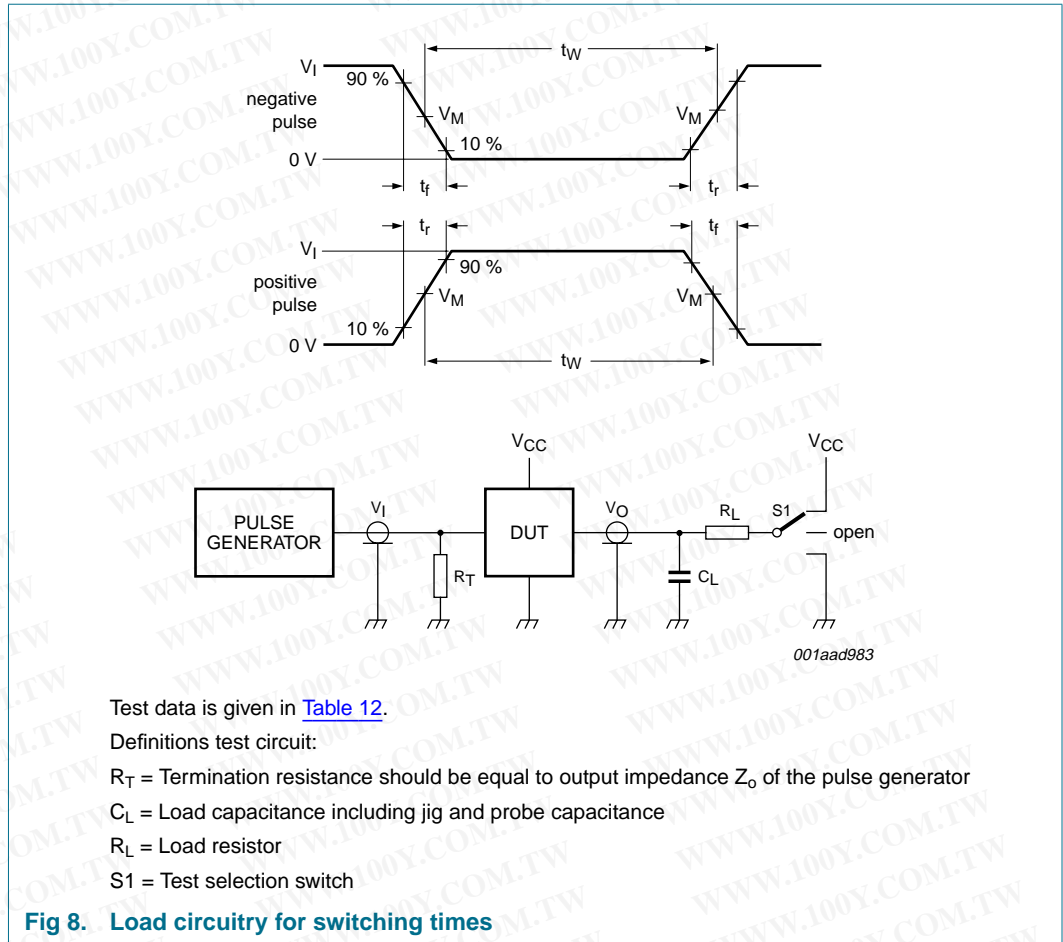

Table 12: Test data

Type	Input		Load		S1 position		
	V_I	t_r, t_f	C_L	R_L	t_{PHL}, t_{PLH}	t_{PZH}, t_{PHZ}	t_{PZL}, t_{PLZ}
74HC244	V_{CC}	6 ns	15 pF, 50 pF	1 k Ω	open	GND	V_{CC}
74HCT244	3 V	6 ns	15 pF, 50 pF	1 k Ω	open	GND	V_{CC}

13. Package outline

DIP20: plastic dual in-line package; 20 leads (300 mil)

SOT146-1

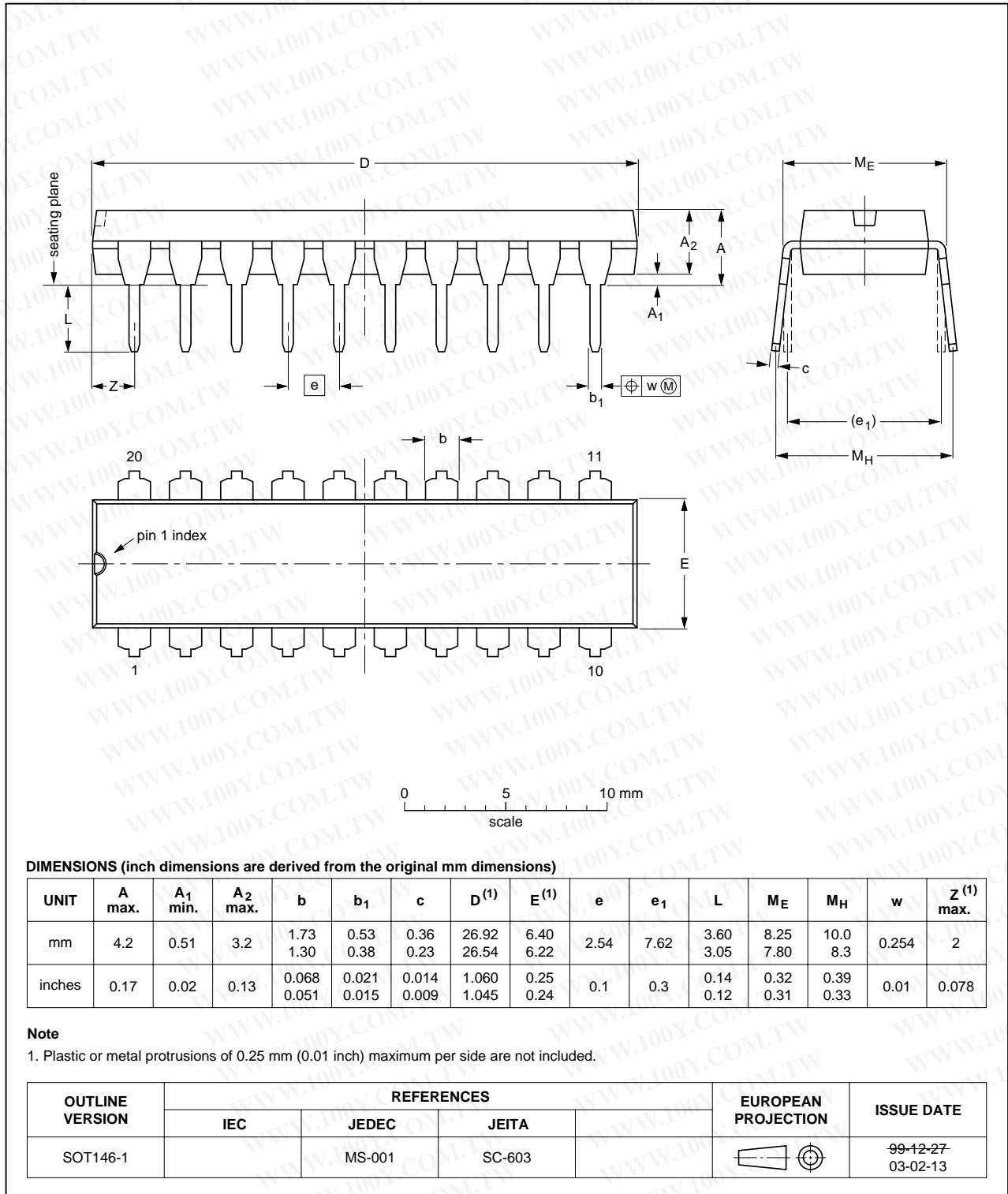

Fig 9. Package outline SOT146-1 (DIP20)

SO20: plastic small outline package; 20 leads; body width 7.5 mm

SOT163-1

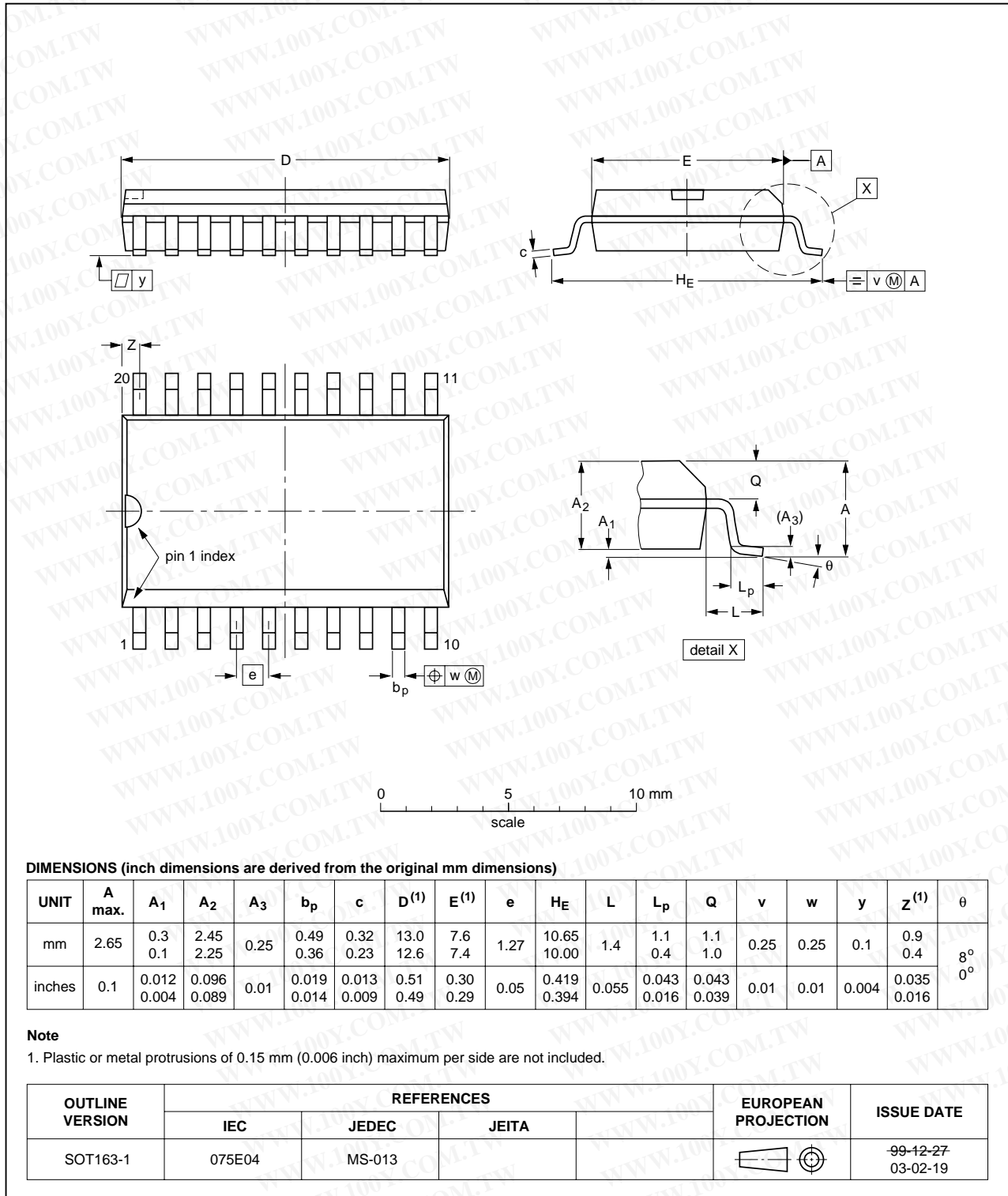

Fig 10. Package outline SOT163-1 (SO20)

SSOP20: plastic shrink small outline package; 20 leads; body width 5.3 mm

SOT339-1

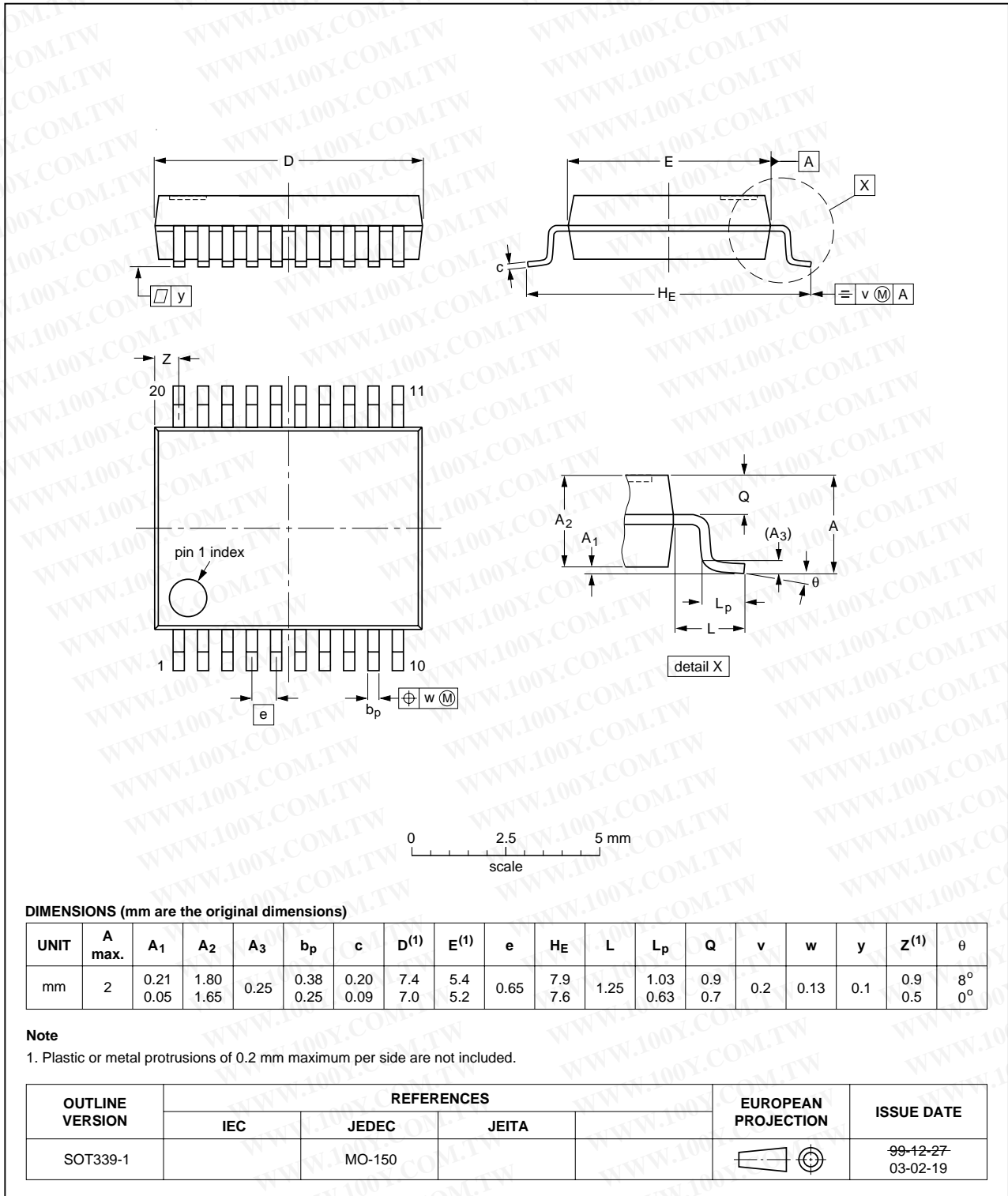

Fig 11. Package outline SOT339-1 (SSOP20)

TSSOP20: plastic thin shrink small outline package; 20 leads; body width 4.4 mm

SOT360-1

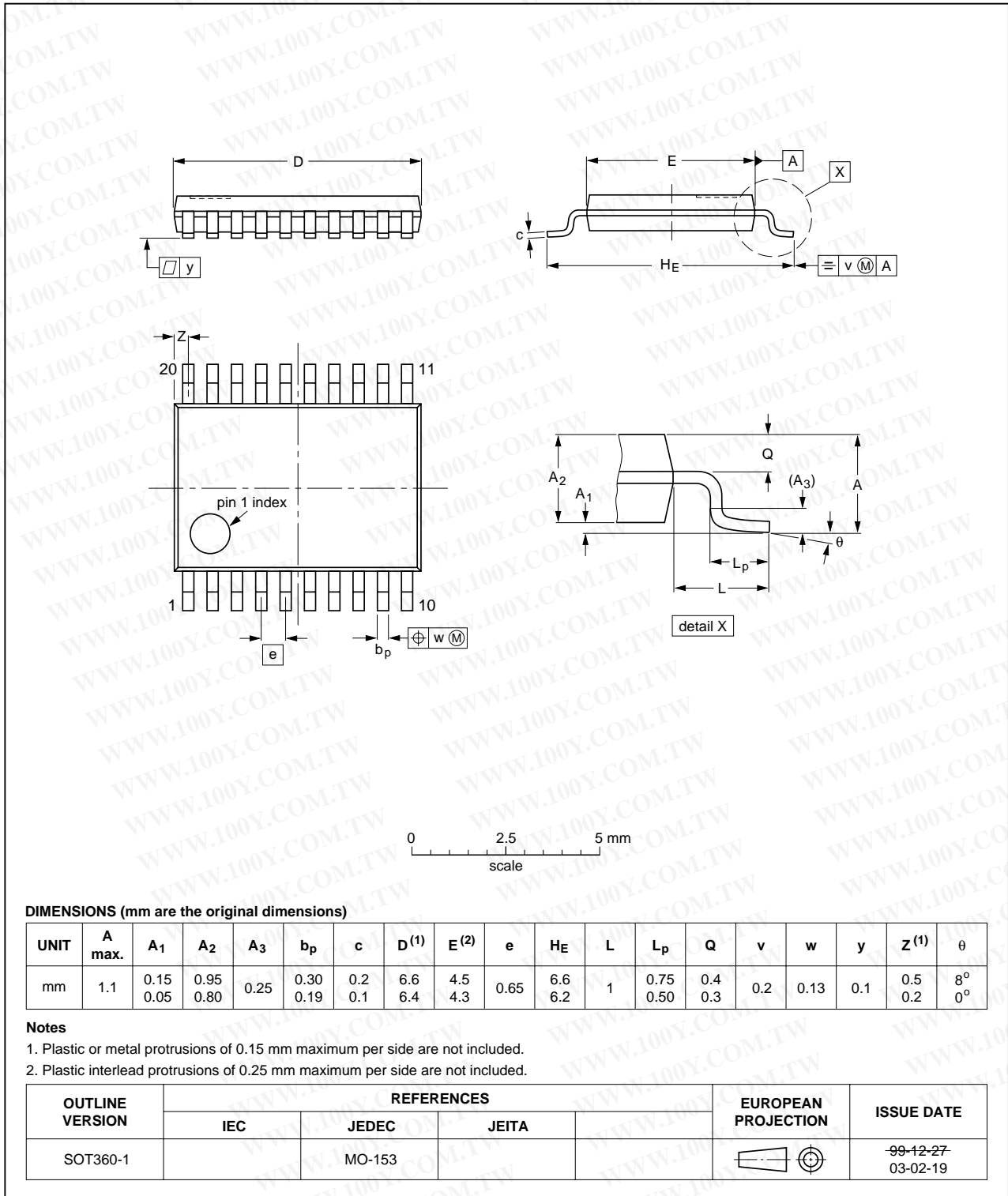

Fig 12. Package outline SOT360-1 (TSSOP20)

DHVQFN20: plastic dual in-line compatible thermal enhanced very thin quad flat package; no leads; 20 terminals; body 2.5 x 4.5 x 0.85 mm

SOT764-1

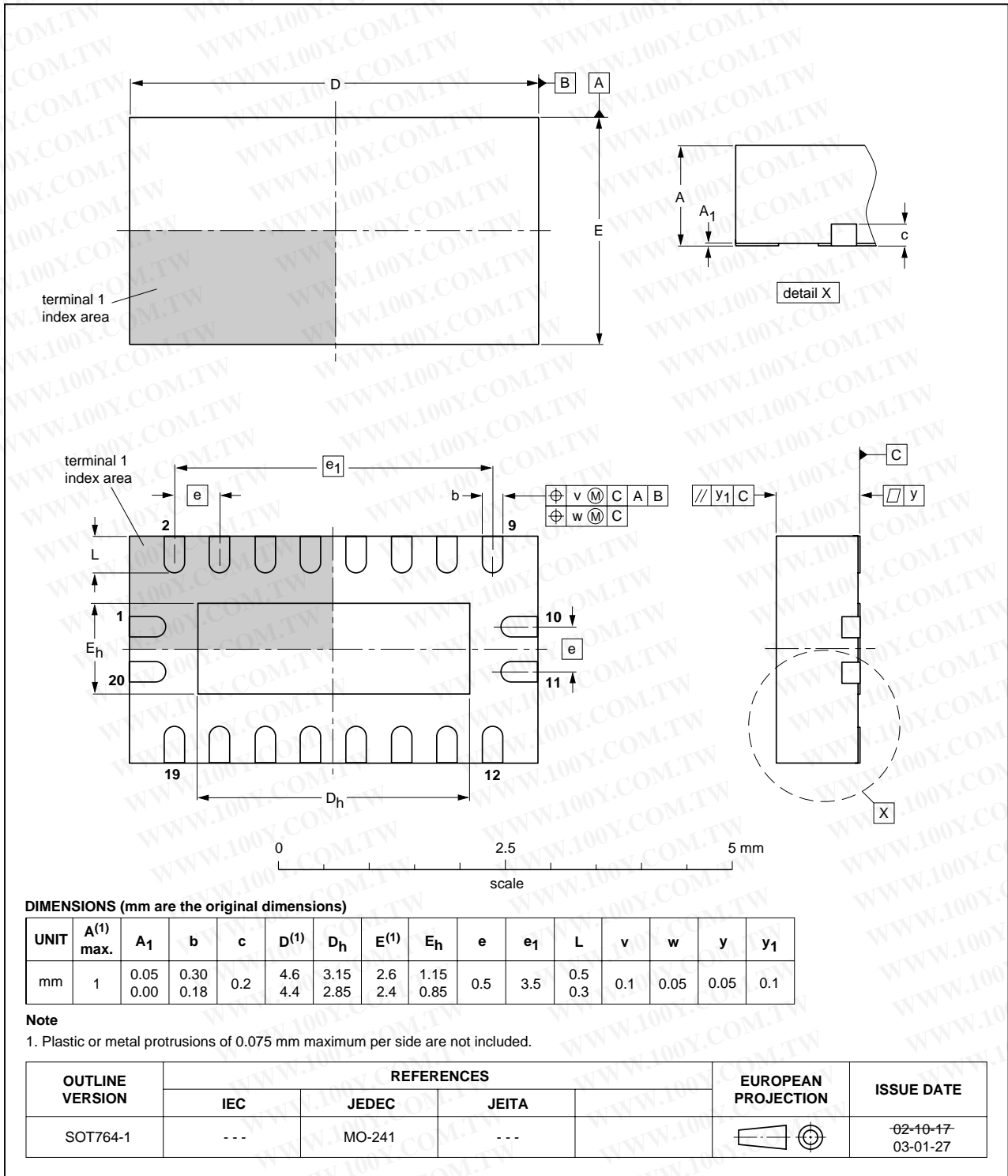

Fig 13. Package outline SOT764-1 (DHVQFN20)

14. Abbreviations

Table 13: Abbreviations

Acronym	Description
CMOS	Complementary Metal Oxide Semiconductor
DUT	Device Under Test
ESD	ElectroStatic Discharge
HBM	Human Body Model
LSTTL	Low-power Schottky Transistor-Transistor Logic
MM	Machine Model

15. Revision history

Table 14: Revision history

Document ID	Release date	Data sheet status	Change notice	Doc. number	Supersedes
74HC_HCT244_3	20051222	Product data sheet	-	-	74HC_HCT244_CNV_2
Modifications:					
					<ul style="list-style-type: none"> The format of this data sheet has been redesigned to comply with the new presentation and information standard of Philips Semiconductors. Section 4 “Ordering information”, Section 6 “Pinning information” and Section 13 “Package outline”: Added DHVQFN package information Section 10 “Static characteristics”: Added from the family specification
74HC_HCT244_CNV_2	19901201	Product specification	-	-	-

16. Data sheet status

Level	Data sheet status ^[1]	Product status ^[2] ^[3]	Definition
I	Objective data	Development	This data sheet contains data from the objective specification for product development. Philips Semiconductors reserves the right to change the specification in any manner without notice.
II	Preliminary data	Qualification	This data sheet contains data from the preliminary specification. Supplementary data will be published at a later date. Philips Semiconductors reserves the right to change the specification without notice, in order to improve the design and supply the best possible product.
III	Product data	Production	This data sheet contains data from the product specification. Philips Semiconductors reserves the right to make changes at any time in order to improve the design, manufacturing and supply. Relevant changes will be communicated via a Customer Product/Process Change Notification (CPCN).

[1] Please consult the most recently issued data sheet before initiating or completing a design.

[2] The product status of the device(s) described in this data sheet may have changed since this data sheet was published. The latest information is available on the Internet at URL <http://www.semiconductors.philips.com>.

[3] For data sheets describing multiple type numbers, the highest-level product status determines the data sheet status.

17. Definitions

Short-form specification — The data in a short-form specification is extracted from a full data sheet with the same type number and title. For detailed information see the relevant data sheet or data handbook.

Limiting values definition — Limiting values given are in accordance with the Absolute Maximum Rating System (IEC 60134). Stress above one or more of the limiting values may cause permanent damage to the device. These are stress ratings only and operation of the device at these or at any other conditions above those given in the Characteristics sections of the specification is not implied. Exposure to limiting values for extended periods may affect device reliability.

Application information — Applications that are described herein for any of these products are for illustrative purposes only. Philips Semiconductors makes no representation or warranty that such applications will be suitable for the specified use without further testing or modification.

customers using or selling these products for use in such applications do so at their own risk and agree to fully indemnify Philips Semiconductors for any damages resulting from such application.

Right to make changes — Philips Semiconductors reserves the right to make changes in the products - including circuits, standard cells, and/or software - described or contained herein in order to improve design and/or performance. When the product is in full production (status 'Production'), relevant changes will be communicated via a Customer Product/Process Change Notification (CPCN). Philips Semiconductors assumes no responsibility or liability for the use of any of these products, conveys no license or title under any patent, copyright, or mask work right to these products, and makes no representations or warranties that these products are free from patent, copyright, or mask work right infringement, unless otherwise specified.

19. Trademarks

Notice — All referenced brands, product names, service names and trademarks are the property of their respective owners.

18. Disclaimers

Life support — These products are not designed for use in life support appliances, devices, or systems where malfunction of these products can reasonably be expected to result in personal injury. Philips Semiconductors

20. Contact information

For additional information, please visit: <http://www.semiconductors.philips.com>

For sales office addresses, send an email to: sales.addresses@www.semiconductors.philips.com

21. Contents

1	General description	1
2	Features	1
3	Quick reference data	1
4	Ordering information	2
5	Functional diagram	3
6	Pinning information	4
6.1	Pinning	4
6.2	Pin description	4
7	Functional description	5
7.1	Function table	5
8	Limiting values	5
9	Recommended operating conditions	6
10	Static characteristics	6
11	Dynamic characteristics	10
12	Waveforms	12
13	Package outline	15
14	Abbreviations	20
15	Revision history	20
16	Data sheet status	21
17	Definitions	21
18	Disclaimers	21
19	Trademarks	21
20	Contact information	21

勝特力材料 886-3-5753170
 勝特力电子(上海) 86-21-34970699
 勝特力电子(深圳) 86-755-83298787
[Http://www.100y.com.tw](http://www.100y.com.tw)



© Koninklijke Philips Electronics N.V. 2005

All rights are reserved. Reproduction in whole or in part is prohibited without the prior written consent of the copyright owner. The information presented in this document does not form part of any quotation or contract, is believed to be accurate and reliable and may be changed without notice. No liability will be accepted by the publisher for any consequence of its use. Publication thereof does not convey nor imply any license under patent- or other industrial or intellectual property rights.

Date of release: 22 December 2005
Document number: 74HC_HCT244_3

Published in The Netherlands