

CD4555BMS CD4556BMS

CMOS Dual Binary to 1 of 4 Decoder/Demultiplexers

December 1992

Features

- High Voltage Type (20V Rating)
- CD4555BMS: Outputs High on Select
- CD4556BMS: Outputs Low on Select
- Expandable with Multiple Packages
- 100% Tested for Quiescent Current at 20V
- Standardized, Symmetrical Output Characteristics
- Maximum Input Current of 1 μ A at 18V Over Full Package Temperature Range; 100nA at 18V and +25°C
- Noise Margin (Over Full Package/Temperature Range)
 - 1V at VDD = 5V
 - 2V at VDD = 10V
 - 2.5V at VDD = 15V
- 5V, 10V and 15V Parametric Ratings
- Meets All Requirements of JEDEC Tentative Standard No. 13B, "Standard Specifications for Description of 'B' Series CMOS Devices"

Applications

- Decoding
- Code Conversion
- Demultiplexing (Using Enable Input as a Data Input)
- Memory Chip-Enable Selection
- Function Selection

Description

CD4555BMS and CD4556BMS are dual one-of-four decoders/demultiplexers. Each decoder has two select inputs (A and B), an Enable input (\bar{E}), and four mutually exclusive outputs. On the CD4555BMS the outputs are high on select; on the CD4556BMS the outputs are low on select.

When the Enable input is high, the outputs of the CD4555BMS remain low and the outputs of the CD4556BMS remain high regardless of the state of the select inputs A and B. The CD4555BMS and CD4556BMS are similar to types MC14555 and MC14556, respectively.

The CD4555BMS and CD4556BMS are supplied in these 16-lead outline packages:

| | | |
|------------------|---------------|------|
| Braze Seal DIP | *H46 | †H4T |
| Frit Seal DIP | H1E | |
| Ceramic Flatpack | H6W | |
| *CD4555B Only | †CD4556B Only | |

Pinouts

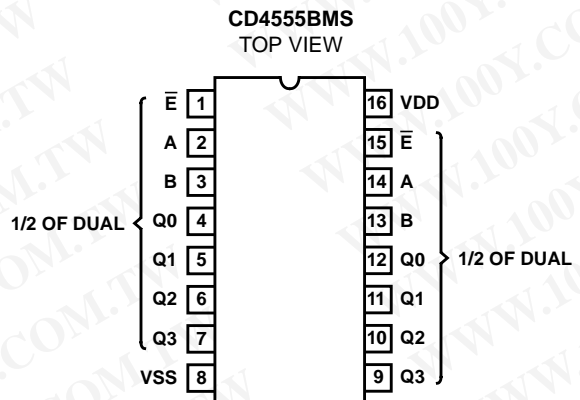
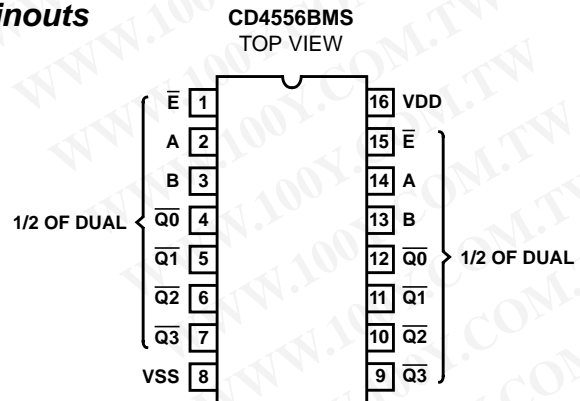

Functional Diagrams

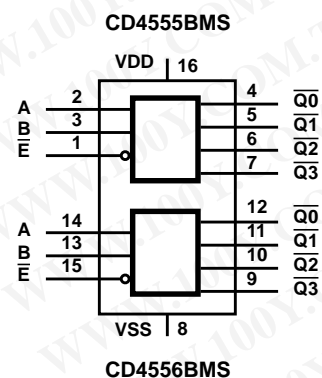
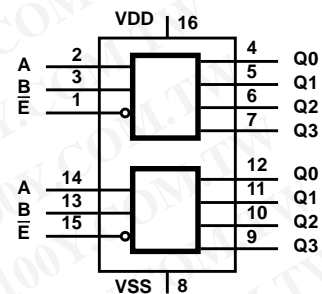

Specifications CD4555BMS, CD4556BMS

Absolute Maximum Ratings

| | |
|---|---|
| DC Supply Voltage Range, (VDD) | -0.5V to +20V (Voltage Referenced to VSS Terminals) |
| Input Voltage Range, All Inputs | -0.5V to VDD +0.5V |
| DC Input Current, Any One Input | ±10mA |
| Operating Temperature Range | -55°C to +125°C Package Types D, F, K, H |
| Storage Temperature Range (TSTG) | -65°C to +150°C |
| Lead Temperature (During Soldering) | +265°C At Distance 1/16 ± 1/32 Inch (1.59mm ± 0.79mm) from case for 10s Maximum |

Reliability Information

| | | |
|---|---|---------------|
| Thermal Resistance | θ_{ja} | θ_{jc} |
| Ceramic DIP and FRIT Package | 80°C/W | 20°C/W |
| Flatpack Package | 70°C/W | 20°C/W |
| Maximum Package Power Dissipation (PD) at +125°C | | |
| For $T_A = -55^\circ\text{C}$ to $+100^\circ\text{C}$ (Package Type D, F, K) | 500mW | |
| For $T_A = +100^\circ\text{C}$ to $+125^\circ\text{C}$ (Package Type D, F, K) | Derate Linearity at 12mW/°C to 200mW | |
| Device Dissipation per Output Transistor | 100mW | |
| For $T_A =$ Full Package Temperature Range (All Package Types) | | |
| Junction Temperature | +175°C | |

TABLE 1. DC ELECTRICAL PERFORMANCE CHARACTERISTICS

| PARAMETER | SYMBOL | CONDITIONS (NOTE 1) | | GROUP A SUBGROUPS | TEMPERATURE | LIMITS | | UNITS |
|-----------------------------|--------|------------------------------------|-----------|----------------------|----------------------|----------------|----------------|-------|
| | | | | | | MIN | MAX | |
| Supply Current | IDD | VDD = 20V, VIN = VDD or GND | | 1 | +25°C | - | 10 | μA |
| | | | | 2 | +125°C | - | 1000 | μA |
| | | VDD = 18V, VIN = VDD or GND | | 3 | -55°C | - | 10 | μA |
| Input Leakage Current | IIL | VIN = VDD or GND | VDD = 20 | 1 | +25°C | -100 | - | nA |
| | | | | 2 | +125°C | -1000 | - | nA |
| | | | VDD = 18V | 3 | -55°C | -100 | - | nA |
| Input Leakage Current | IIH | VIN = VDD or GND | VDD = 20 | 1 | +25°C | - | 100 | nA |
| | | | | 2 | +125°C | - | 1000 | nA |
| | | | VDD = 18V | 3 | -55°C | - | 100 | nA |
| Output Voltage | VOL15 | VDD = 15V, No Load | | 1, 2, 3 | +25°C, +125°C, -55°C | - | 50 | mV |
| Output Voltage | VOH15 | VDD = 15V, No Load (Note 3) | | 1, 2, 3 | +25°C, +125°C, -55°C | 14.95 | - | V |
| Output Current (Sink) | IOL5 | VDD = 5V, VOUT = 0.4V | | 1 | +25°C | 0.53 | - | mA |
| Output Current (Sink) | IOL10 | VDD = 10V, VOUT = 0.5V | | 1 | +25°C | 1.4 | - | mA |
| Output Current (Sink) | IOL15 | VDD = 15V, VOUT = 1.5V | | 1 | +25°C | 3.5 | - | mA |
| Output Current (Source) | IOH5A | VDD = 5V, VOUT = 4.6V | | 1 | +25°C | - | -0.53 | mA |
| Output Current (Source) | IOH5B | VDD = 5V, VOUT = 2.5V | | 1 | +25°C | - | -1.8 | mA |
| Output Current (Source) | IOH10 | VDD = 10V, VOUT = 9.5V | | 1 | +25°C | - | -1.4 | mA |
| Output Current (Source) | IOH15 | VDD = 15V, VOUT = 13.5V | | 1 | +25°C | - | -3.5 | mA |
| N Threshold Voltage | VNTH | VDD = 10V, ISS = -10μA | | 1 | +25°C | -2.8 | -0.7 | V |
| P Threshold Voltage | VPTH | VSS = 0V, IDD = 10μA | | 1 | +25°C | 0.7 | 2.8 | V |
| Functional | F | VDD = 2.8V, VIN = VDD or GND | | 7 | +25°C | VOH > VDD/2 | VOL < VDD/2 | V |
| | | VDD = 20V, VIN = VDD or GND | | 7 | +25°C | | | |
| | | VDD = 18V, VIN = VDD or GND | | 8A | +125°C | | | |
| | | VDD = 3V, VIN = VDD or GND | | 8B | -55°C | | | |
| Input Voltage Low (Note 2) | VIL | VDD = 5V, VOH > 4.5V, VOL < 0.5V | | 1, 2, 3 | +25°C, +125°C, -55°C | - | 1.5 | V |
| Input Voltage High (Note 2) | VIH | VDD = 5V, VOH > 4.5V, VOL < 0.5V | | 1, 2, 3 | +25°C, +125°C, -55°C | 3.5 | - | V |
| Input Voltage Low (Note 2) | VIL | VDD = 15V, VOH > 13.5V, VOL < 1.5V | | 1, 2, 3 | +25°C, +125°C, -55°C | - | 4 | V |
| Input Voltage High (Note 2) | VIH | VDD = 15V, VOH > 13.5V, VOL < 1.5V | | 1, 2, 3 | +25°C, +125°C, -55°C | 11 | - | V |

NOTES: 1. All voltages referenced to device GND, 100% testing being implemented. 2. Go/No Go test with limits applied to inputs. 3. For accuracy, voltage is measured differentially to VDD. Limit is 0.050V max.

勝特力材料 886-3-5753170
 勝特力电子(上海) 86-21-34970699
 勝特力电子(深圳) 86-755-83298787
[Http://www.100y.com.tw](http://www.100y.com.tw)

Specifications CD4555BMS, CD4556BMS

TABLE 2. AC ELECTRICAL PERFORMANCE CHARACTERISTICS

| PARAMETER | SYMBOL | CONDITIONS (NOTE 1, 2) | GROUP A SUBGROUPS | TEMPERATURE | LIMITS | | UNITS |
|---|----------------|----------------------------|----------------------|---------------|--------|-----|-------|
| | | | | | MIN | MAX | |
| Propagation Delay A or B Input to any Output | TPHL1 TPLH1 | VDD = 5V, VIN = VDD or GND | 9 | +25°C | - | 440 | ns |
| | | | 10, 11 | +125°C, -55°C | - | 594 | ns |
| Propagation Delay E to any Output | TPHL2 TPLH2 | VDD = 5V, VIN = VDD or GND | 9 | +25°C | - | 400 | ns |
| | | | 10, 11 | +125°C, -55°C | - | 540 | ns |
| Transition Time | TTHL TTLH | VDD = 5V, VIN = VDD or GND | 9 | +25°C | - | 200 | ns |
| | | | 10, 11 | +125°C, -55°C | - | 270 | ns |

NOTES:

1. CL = 50pF, RL = 200K, Input TR, TF < 20ns.
2. -55°C and +125°C limits guaranteed, 100% testing being implemented.

TABLE 3. ELECTRICAL PERFORMANCE CHARACTERISTICS

| PARAMETER | SYMBOL | CONDITIONS | NOTES | TEMPERATURE | LIMITS | | UNITS |
|-------------------------|--------|-------------------------------|-------|-------------------------|--------|-------|-------|
| | | | | | MIN | MAX | |
| Supply Current | IDD | VDD = 5V, VIN = VDD or GND | 1, 2 | -55°C, +25°C | - | 5 | μA |
| | | | | +125°C | - | 150 | μA |
| | | VDD = 10V, VIN = VDD or GND | 1, 2 | -55°C, +25°C | - | 10 | μA |
| | | | | +125°C | - | 300 | μA |
| | | VDD = 15V, VIN = VDD or GND | 1, 2 | -55°C, +25°C | - | 10 | μA |
| | | | | +125°C | - | 600 | μA |
| Output Voltage | VOL | VDD = 5V, No Load | 1, 2 | +25°C, +125°C, -55°C | - | 50 | mV |
| Output Voltage | VOL | VDD = 10V, No Load | 1, 2 | +25°C, +125°C, -55°C | - | 50 | mV |
| Output Voltage | VOH | VDD = 5V, No Load | 1, 2 | +25°C, +125°C, -55°C | 4.95 | - | V |
| Output Voltage | VOH | VDD = 10V, No Load | 1, 2 | +25°C, +125°C, -55°C | 9.95 | - | V |
| Output Current (Sink) | IOL5 | VDD = 5V, VOUT = 0.4V | 1, 2 | +125°C | 0.36 | - | mA |
| | | | | -55°C | 0.64 | - | mA |
| Output Current (Sink) | IOL10 | VDD = 10V, VOUT = 0.5V | 1, 2 | +125°C | 0.9 | - | mA |
| | | | | -55°C | 1.6 | - | mA |
| Output Current (Sink) | IOL15 | VDD = 15V, VOUT = 1.5V | 1, 2 | +125°C | 2.4 | - | mA |
| | | | | -55°C | 4.2 | - | mA |
| Output Current (Source) | IOH5A | VDD = 5V, VOUT = 4.6V | 1, 2 | +125°C | - | -0.36 | mA |
| | | | | -55°C | - | -0.64 | mA |
| Output Current (Source) | IOH5B | VDD = 5V, VOUT = 2.5V | 1, 2 | +125°C | - | -1.15 | mA |
| | | | | -55°C | - | -2.0 | mA |
| Output Current (Source) | IOH10 | VDD = 10V, VOUT = 9.5V | 1, 2 | +125°C | - | -0.9 | mA |
| | | | | -55°C | - | -1.6 | mA |
| Output Current (Source) | IOH15 | VDD = 15V, VOUT = 13.5V | 1, 2 | +125°C | - | -2.4 | mA |
| | | | | -55°C | - | -4.2 | mA |
| Input Voltage Low | VIL | VDD = 10V, VOH > 9V, VOL < 1V | 1, 2 | +25°C, +125°C, -55°C | - | 3 | V |
| Input Voltage High | VIH | VDD = 10V, VOH > 9V, VOL < 1V | 1, 2 | +25°C, +125°C, -55°C | 7 | - | V |

勝特力材料 886-3-5753170
 勝特力电子(上海) 86-21-34970699
 勝特力电子(深圳) 86-755-83298787
[Http://www.100y.com.tw](http://www.100y.com.tw)

Specifications CD4555BMS, CD4556BMS

TABLE 3. ELECTRICAL PERFORMANCE CHARACTERISTICS (Continued)

| PARAMETER | SYMBOL | CONDITIONS | NOTES | TEMPERATURE | LIMITS | | UNITS |
|---|----------------|------------|---------|-------------|--------|-----|-------|
| | | | | | MIN | MAX | |
| Propagation Delay A or B Input to any Output | TPHL1 TPLH1 | VDD = 10V | 1, 2, 3 | +25°C | - | 190 | ns |
| | | VDD = 15V | 1, 2, 3 | +25°C | - | 140 | ns |
| Propagation Delay \bar{E} to any Output | TPHL2 TPLH2 | VDD = 10V | 1, 2, 3 | +25°C | - | 170 | ns |
| | | VDD = 15V | 1, 2, 3 | +25°C | - | 130 | ns |
| Transition Time | TTHL TTLH | VDD = 10V | 1, 2, 3 | +25°C | - | 100 | ns |
| | | VDD = 15V | 1, 2, 3 | +25°C | - | 80 | ns |
| Input Capacitance | CIN | Any Input | 1, 2 | +25°C | - | 7.5 | pF |

NOTES:

- All voltages referenced to device GND.
- The parameters listed on Table 3 are controlled via design or process and are not directly tested. These parameters are characterized on initial design release and upon design changes which would affect these characteristics.
- CL = 50pF, RL = 200K, Input TR, TF < 20ns.

TABLE 4. POST IRRADIATION ELECTRICAL PERFORMANCE CHARACTERISTICS

| PARAMETER | SYMBOL | CONDITIONS | NOTES | TEMPERATURE | LIMITS | | UNITS |
|------------------------------|--------------|-----------------------------|------------|-------------|----------------|--------------------------|-------|
| | | | | | MIN | MAX | |
| Supply Current | IDD | VDD = 20V, VIN = VDD or GND | 1, 4 | +25°C | - | 25 | μA |
| N Threshold Voltage | VNTH | VDD = 10V, ISS = -10μA | 1, 4 | +25°C | -2.8 | -0.2 | V |
| N Threshold Voltage Delta | ΔVTN | VDD = 10V, ISS = -10μA | 1, 4 | +25°C | - | ±1 | V |
| P Threshold Voltage | VTP | VSS = 0V, IDD = 10μA | 1, 4 | +25°C | 0.2 | 2.8 | V |
| P Threshold Voltage Delta | ΔVTP | VSS = 0V, IDD = 10μA | 1, 4 | +25°C | - | ±1 | V |
| Functional | F | VDD = 18V, VIN = VDD or GND | 1 | +25°C | VOH > VDD/2 | VOL < VDD/2 | V |
| | | VDD = 3V, VIN = VDD or GND | | | | | |
| Propagation Delay Time | TPHL TPLH | VDD = 5V | 1, 2, 3, 4 | +25°C | - | 1.35 x +25°C Limit | ns |

- NOTES: 1. All voltages referenced to device GND. 2. CL = 50pF, RL = 200K, Input TR, TF < 20ns. 3. See Table 2 for +25°C limit. 4. Read and Record

TABLE 5. BURN-IN AND LIFE TEST DELTA PARAMETERS +25°C

| PARAMETER | SYMBOL | DELTA LIMIT |
|-------------------------|--------|--------------------------|
| Supply Current - MSI-2 | IDD | ± 1.0μA |
| Output Current (Sink) | IOL5 | ± 20% x Pre-Test Reading |
| Output Current (Source) | IOH5A | ± 20% x Pre-Test Reading |

勝特力材料 886-3-5753170
 勝特力电子(上海) 86-21-34970699
 勝特力电子(深圳) 86-755-83298787
[Http://www.100y.com.tw](http://www.100y.com.tw)

TABLE 6. APPLICABLE SUBGROUPS

| CONFORMANCE GROUP | MIL-STD-883 METHOD | GROUP A SUBGROUPS | READ AND RECORD |
|-------------------------------|-----------------------|-------------------|------------------|
| Initial Test (Pre Burn-In) | 100% 5004 | 1, 7, 9 | IDD, IOL5, IOH5A |
| Interim Test 1 (Post Burn-In) | 100% 5004 | 1, 7, 9 | IDD, IOL5, IOH5A |
| Interim Test 2 (Post Burn-In) | 100% 5004 | 1, 7, 9 | IDD, IOL5, IOH5A |
| PDA (Note 1) | 100% 5004 | 1, 7, 9, Deltas | |
| Interim Test 3 (Post Burn-In) | 100% 5004 | 1, 7, 9 | IDD, IOL5, IOH5A |
| PDA (Note 1) | 100% 5004 | 1, 7, 9, Deltas | |

Specifications CD4555BMS, CD4556BMS

TABLE 6. APPLICABLE SUBGROUPS

| CONFORMANCE GROUP | | MIL-STD-883 METHOD | GROUP A SUBGROUPS | READ AND RECORD |
|-------------------|--------------|--------------------|---------------------------------------|------------------------------|
| Final Test | | 100% 5004 | 2, 3, 8A, 8B, 10, 11 | |
| Group A | | Sample 5005 | 1, 2, 3, 7, 8A, 8B, 9, 10, 11 | |
| Group B | Subgroup B-5 | Sample 5005 | 1, 2, 3, 7, 8A, 8B, 9, 10, 11, Deltas | Subgroups 1, 2, 3, 9, 10, 11 |
| | Subgroup B-6 | Sample 5005 | 1, 7, 9 | |
| Group D | | Sample 5005 | 1, 2, 3, 8A, 8B, 9 | Subgroups 1, 2, 3 |

NOTE: 1. 5% Parametric, 3% Functional; Cumulative for Static 1 and 2.

TABLE 7. TOTAL DOSE IRRADIATION

| CONFORMANCE GROUPS | MIL-STD-883 METHOD | TEST | | READ AND RECORD | |
|--------------------|--------------------|-----------|------------|-----------------|------------|
| | | PRE-IRRAD | POST-IRRAD | PRE-IRRAD | POST-IRRAD |
| Group E Subgroup 2 | 5005 | 1, 7, 9 | Table 4 | 1, 9 | Table 4 |

TABLE 8. BURN-IN AND IRRADIATION TEST CONNECTIONS

| FUNCTION | OPEN | GROUND | VDD | 9V ± 0.5V | OSCILLATOR | |
|-----------------------------------|---------------|-------------------|----------------|---------------|------------|-------|
| | | | | | 50kHz | 25kHz |
| PART NUMBER CD4555BMS & CD4556BMS | | | | | | |
| Static Burn-In 1 Note 1 | 4 - 7, 9 - 12 | 1 - 3, 8, 13 - 15 | 16 | | | |
| Static Burn-In 2 Note 1 | 4 - 7, 9 - 12 | 8 | 1 - 3, 13 - 16 | | | |
| Dynamic Burn-In Note 1 | - | 1, 8, 15 | 16 | 4 - 7, 9 - 12 | 2, 14 | 3, 13 |
| Irradiation Note 2 | | | | | | |

NOTE:

1. Each pin except VDD and GND will have a series resistor of $10K \pm 5\%$, $VDD = 18V \pm 0.5V$
2. Each pin except VDD and GND will have a series resistor of $47K \pm 5\%$; Group E, Subgroup 2, sample size is 4 dice/wafer, 0 failures, $VDD = 10V \pm 0.5V$

Logic Diagrams

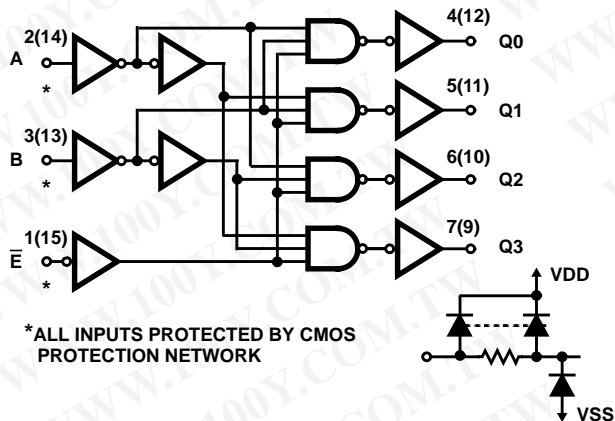

FIGURE 1. CD4555BMS LOGIC DIAGRAM (1 OF 2 IDENTICAL CIRCUITS)

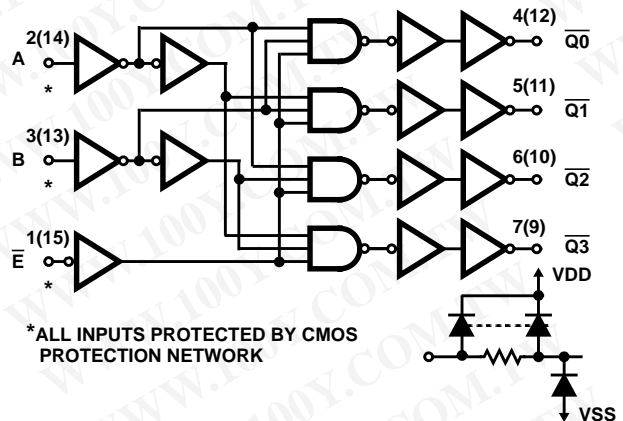

FIGURE 2. CD4556BMS LOGIC DIAGRAM (1 OF 2 IDENTICAL CIRCUITS)

勝特力材料 886-3-5753170
勝特力电子(上海) 86-21-34970699
勝特力电子(深圳) 86-755-83298787
[Http://www.100y.com.tw](http://www.100y.com.tw)

CD4555BMS, CD4556BMS

TRUTH TABLE

| INPUTS ENABLE SELECT | | | OUTPUTS CD4555BMS | | | | OUTPUTS CD4556BMS | | | |
|----------------------|---|---|-------------------|----|----|----|-------------------|----|----|----|
| E | B | A | Q3 | Q2 | Q1 | Q0 | Q3 | Q2 | Q1 | Q0 |
| 0 | 0 | 0 | 0 | 0 | 0 | 1 | 1 | 1 | 1 | 0 |
| 0 | 0 | 1 | 0 | 0 | 1 | 0 | 1 | 1 | 0 | 1 |
| 0 | 1 | 0 | 0 | 1 | 0 | 0 | 1 | 0 | 1 | 1 |
| 0 | 1 | 1 | 1 | 0 | 0 | 0 | 0 | 1 | 1 | 1 |
| 1 | X | X | 0 | 0 | 0 | 0 | 1 | 1 | 1 | 1 |

X = Don't Care

Logic 1 = High
Logic 0 = Low

Typical Performance Characteristics

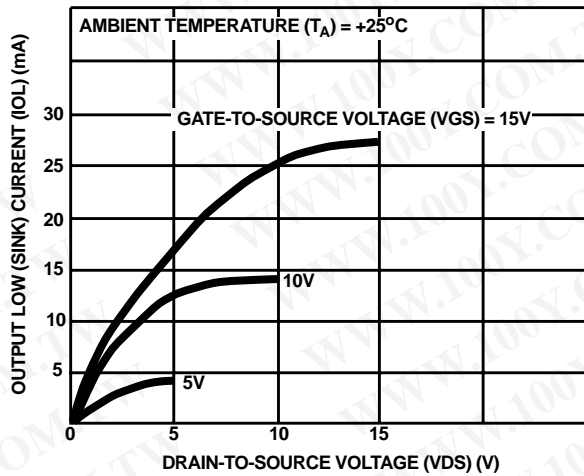

FIGURE 3. TYPICAL OUTPUT LOW (SINK) CURRENT CHARACTERISTICS

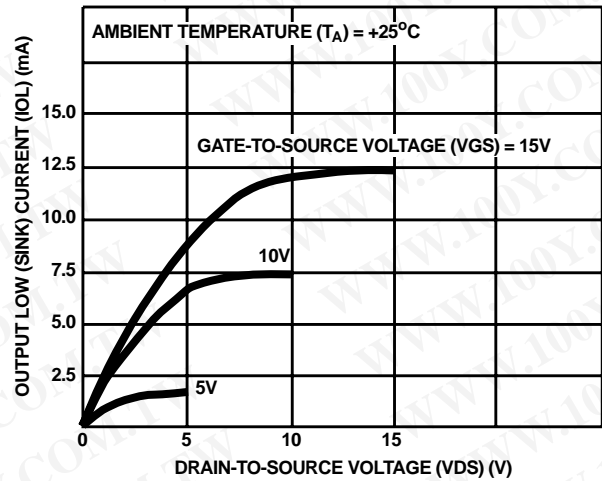

FIGURE 4. MINIMUM OUTPUT LOW (SINK) CURRENT CHARACTERISTICS

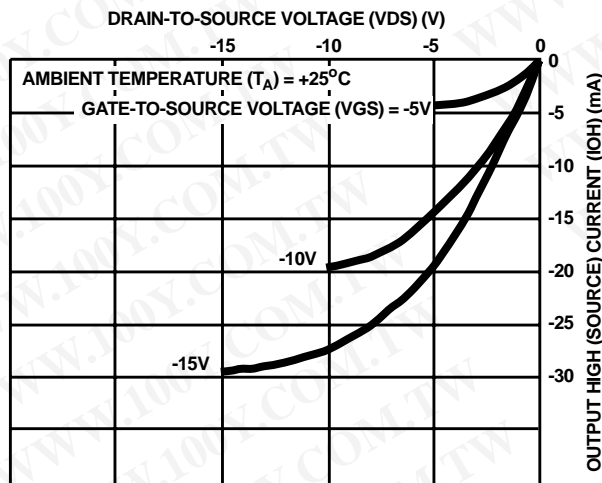

FIGURE 5. TYPICAL OUTPUT HIGH (SOURCE) CURRENT CHARACTERISTICS

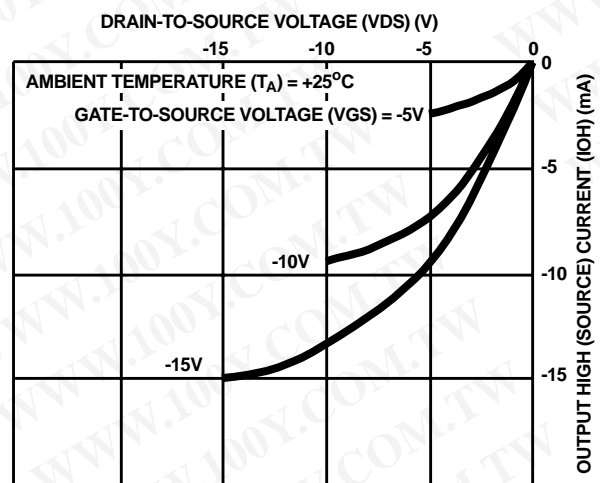

FIGURE 6. MINIMUM OUTPUT HIGH (SOURCE) CURRENT CHARACTERISTICS

勝特力材料 886-3-5753170
勝特力电子(上海) 86-21-34970699
勝特力电子(深圳) 86-755-83298787
[Http://www.100y.com.tw](http://www.100y.com.tw)

Typical Performance Characteristics (Continued)

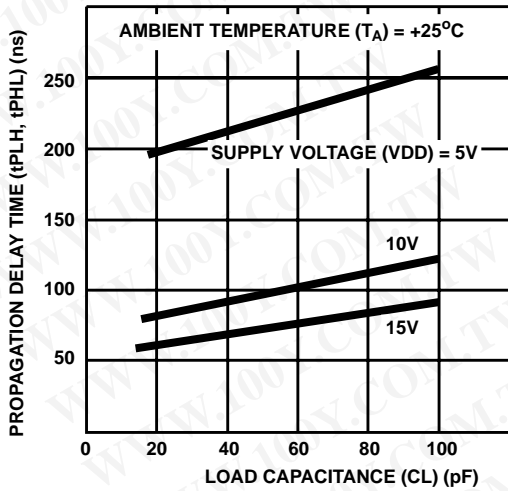

FIGURE 7. TYPICAL PROPAGATION DELAY TIME vs LOAD CAPACITANCE (A OR B INPUT TO ANY OUTPUT)

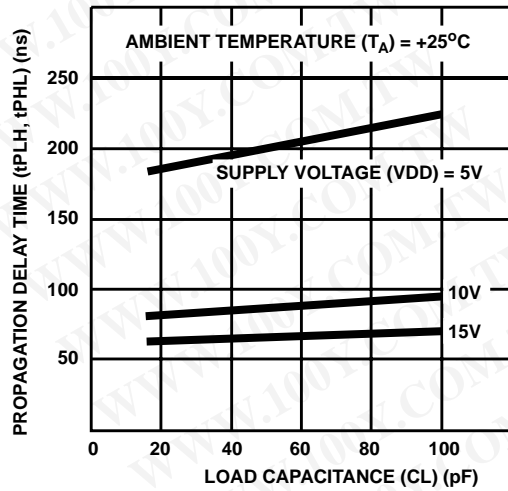

FIGURE 8. TYPICAL PROPAGATION DELAY TIME vs LOAD CAPACITANCE (E INPUTS TO ANY OUTPUT)

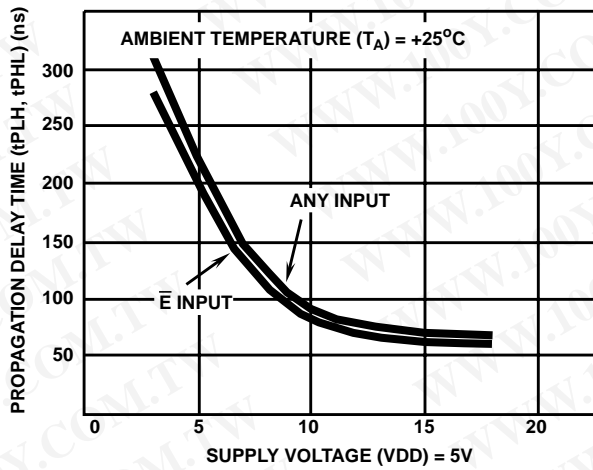

FIGURE 9. TYPICAL PROPAGATION DELAY TIME vs SUPPLY VOLTAGE

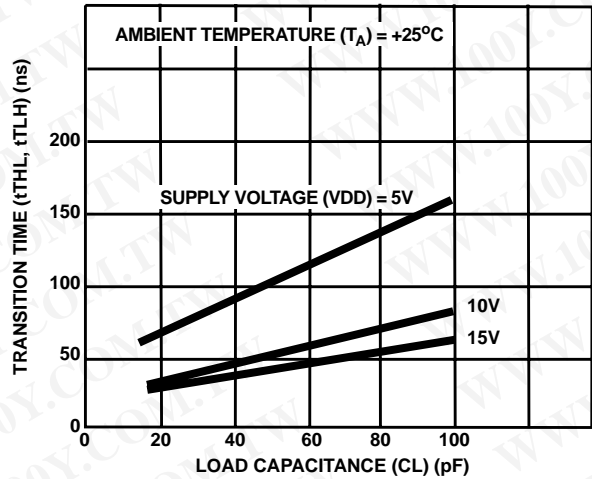

FIGURE 10. TYPICAL TRANSITION TIME vs LOAD CAPACITANCE

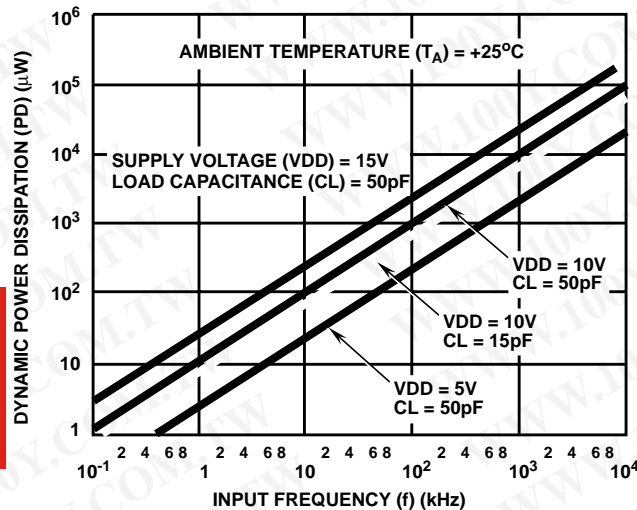

FIGURE 11. TYPICAL DYNAMIC POWER DISSIPATION vs FREQUENCY

勝特力材料 886-3-5753170
 勝特力电子(上海) 86-21-34970699
 勝特力电子(深圳) 86-755-83298787
[Http://www.100y.com.tw](http://www.100y.com.tw)

CD4555BMS, CD4556BMS

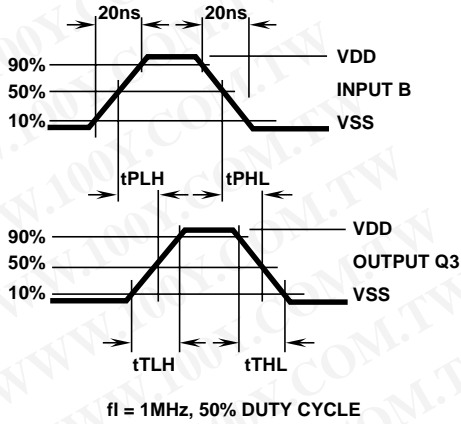

FIGURE 12. CD4555BMS B INPUT TO Q3 OUTPUT DYNAMIC SIGNAL WAVEFORMS

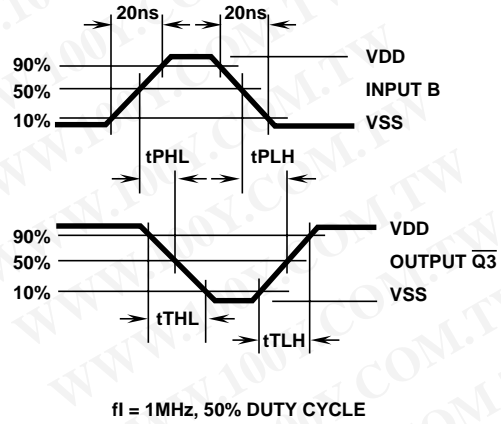

FIGURE 13. CD4556BMS B INPUT TO \bar{Q}_3 OUTPUT DYNAMIC SIGNAL WAVEFORMS

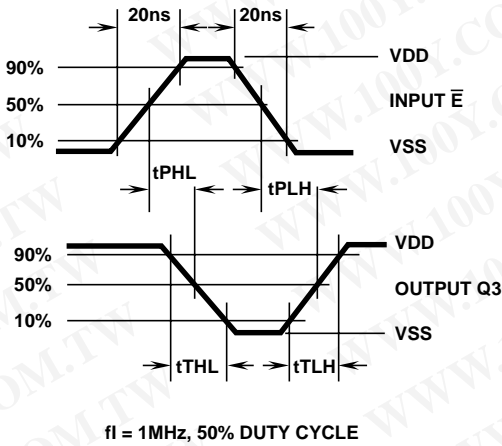

FIGURE 14. CD4555BMS \bar{E} INPUT TO Q3 OUTPUT DYNAMIC SIGNAL WAVEFORMS

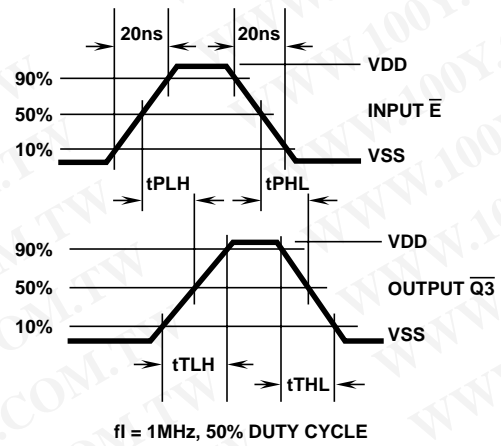

FIGURE 15. CD4556BMS \bar{E} INPUT TO \bar{Q}_3 OUTPUT DYNAMIC SIGNAL WAVEFORMS

Applications

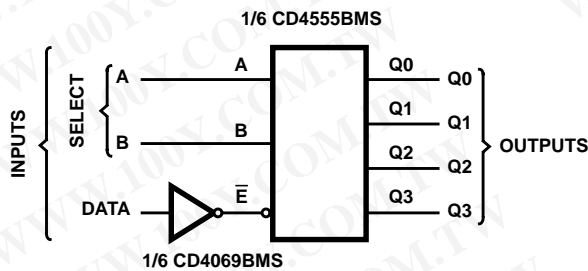

FIGURE 16. 1 OF 4 LINE DATA DEMULTIPLEXER USING CD4555BMS

TRUTH TABLE

| SELECT INPUTS | | OUTPUTS | | | |
|---------------|---|---------|------|------|------|
| B | A | Q0 | Q1 | Q2 | Q3 |
| 0 | 0 | DATA | 0 | 0 | 0 |
| 0 | 1 | 0 | DATA | 0 | 0 |
| 1 | 0 | 0 | 0 | DATA | 0 |
| 1 | 1 | 0 | 0 | 0 | DATA |

勝特力材料 886-3-5753170
 勝特力电子(上海) 86-21-34970699
 勝特力电子(深圳) 86-755-83298787
[Http://www.100y.com.tw](http://www.100y.com.tw)

CD4555BMS, CD4556BMS

Applications (Continued)

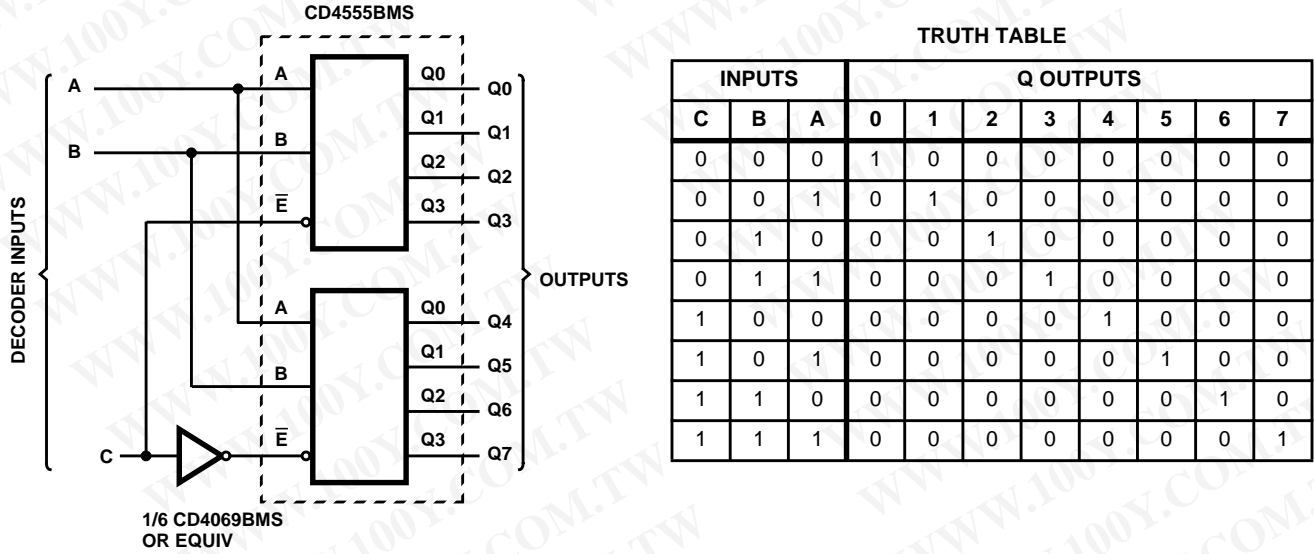

FIGURE 17. 1 OF 8 DECODER USING CD4555BMS

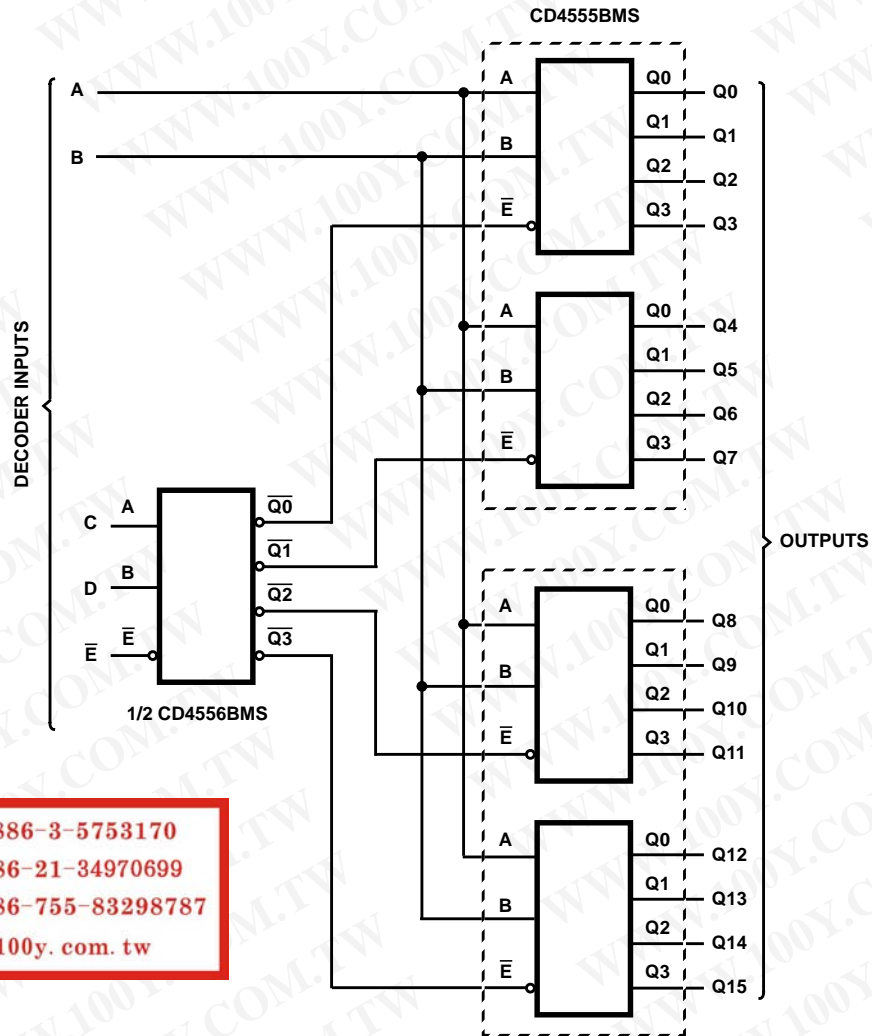

FIGURE 18. 1 OF 16 DECODER USING CD4555BMS AND CD4556BMS

勝特力材料 886-3-5753170
 勝特力电子(上海) 86-21-34970699
 勝特力电子(深圳) 86-755-83298787
[Http://www.100y.com.tw](http://www.100y.com.tw)

CD4555BMS, CD4556BMS

勝特力材料 886-3-5753170
 勝特力电子(上海) 86-21-34970699
 勝特力电子(深圳) 86-755-83298787
[Http://www.100y.com.tw](http://www.100y.com.tw)

TRUTH TABLE

| INPUTS | | | | | Q OUTPUTS | | | | | | | | | | | | | | | | |
|--------|---|---|---|---|-----------|---|---|---|---|---|---|---|---|---|----|----|----|----|----|----|---|
| E | D | C | B | A | 0 | 1 | 2 | 3 | 4 | 5 | 6 | 7 | 8 | 9 | 10 | 11 | 12 | 13 | 14 | 15 | |
| 0 | 0 | 0 | 0 | 0 | 1 | 0 | 0 | 0 | 0 | 0 | 0 | 0 | 0 | 0 | 0 | 0 | 0 | 0 | 0 | 0 | 0 |
| 0 | 0 | 0 | 0 | 1 | 0 | 1 | 0 | 0 | 0 | 0 | 0 | 0 | 0 | 0 | 0 | 0 | 0 | 0 | 0 | 0 | 0 |
| 0 | 0 | 0 | 1 | 0 | 0 | 0 | 1 | 0 | 0 | 0 | 0 | 0 | 0 | 0 | 0 | 0 | 0 | 0 | 0 | 0 | 0 |
| 0 | 0 | 0 | 1 | 1 | 0 | 0 | 0 | 1 | 0 | 0 | 0 | 0 | 0 | 0 | 0 | 0 | 0 | 0 | 0 | 0 | 0 |
| 0 | 0 | 1 | 0 | 0 | 0 | 0 | 0 | 0 | 1 | 0 | 0 | 0 | 0 | 0 | 0 | 0 | 0 | 0 | 0 | 0 | 0 |
| 0 | 0 | 1 | 0 | 1 | 0 | 0 | 0 | 0 | 0 | 1 | 0 | 0 | 0 | 0 | 0 | 0 | 0 | 0 | 0 | 0 | 0 |
| 0 | 0 | 1 | 1 | 0 | 0 | 0 | 0 | 0 | 0 | 0 | 1 | 0 | 0 | 0 | 0 | 0 | 0 | 0 | 0 | 0 | 0 |
| 0 | 0 | 1 | 1 | 1 | 0 | 0 | 0 | 0 | 0 | 0 | 0 | 1 | 0 | 0 | 0 | 0 | 0 | 0 | 0 | 0 | 0 |
| 0 | 1 | 0 | 0 | 0 | 0 | 0 | 0 | 0 | 0 | 0 | 0 | 0 | 1 | 0 | 0 | 0 | 0 | 0 | 0 | 0 | 0 |
| 0 | 1 | 0 | 0 | 1 | 0 | 0 | 0 | 0 | 0 | 0 | 0 | 0 | 0 | 1 | 0 | 0 | 0 | 0 | 0 | 0 | 0 |
| 0 | 1 | 0 | 1 | 0 | 0 | 0 | 0 | 0 | 0 | 0 | 0 | 0 | 0 | 0 | 1 | 0 | 0 | 0 | 0 | 0 | 0 |
| 0 | 1 | 0 | 1 | 1 | 0 | 0 | 0 | 0 | 0 | 0 | 0 | 0 | 0 | 0 | 0 | 1 | 0 | 0 | 0 | 0 | 0 |
| 0 | 1 | 1 | 0 | 0 | 0 | 0 | 0 | 0 | 0 | 0 | 0 | 0 | 0 | 0 | 0 | 0 | 1 | 0 | 0 | 0 | 0 |
| 0 | 1 | 1 | 0 | 1 | 0 | 0 | 0 | 0 | 0 | 0 | 0 | 0 | 0 | 0 | 0 | 0 | 0 | 1 | 0 | 0 | 0 |
| 0 | 1 | 1 | 1 | 0 | 0 | 0 | 0 | 0 | 0 | 0 | 0 | 0 | 0 | 0 | 0 | 0 | 0 | 0 | 1 | 0 | 0 |
| 0 | 1 | 1 | 1 | 1 | 0 | 0 | 0 | 0 | 0 | 0 | 0 | 0 | 0 | 0 | 0 | 0 | 0 | 0 | 0 | 1 | 0 |
| 0 | 1 | 1 | 1 | 1 | 0 | 0 | 0 | 0 | 0 | 0 | 0 | 0 | 0 | 0 | 0 | 0 | 0 | 0 | 0 | 0 | 1 |
| 1 | X | X | X | 0 | 0 | 0 | 0 | 0 | 0 | 0 | 0 | 0 | 0 | 0 | 0 | 0 | 0 | 0 | 0 | 0 | 0 |

X = Don't Care

Chip Dimensions and Pad Layouts

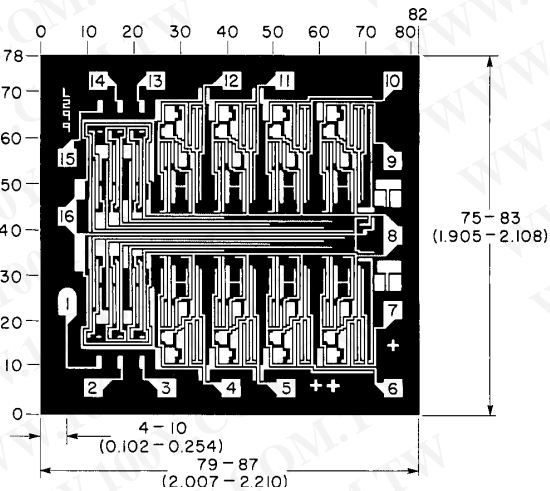

CD4555BMSH

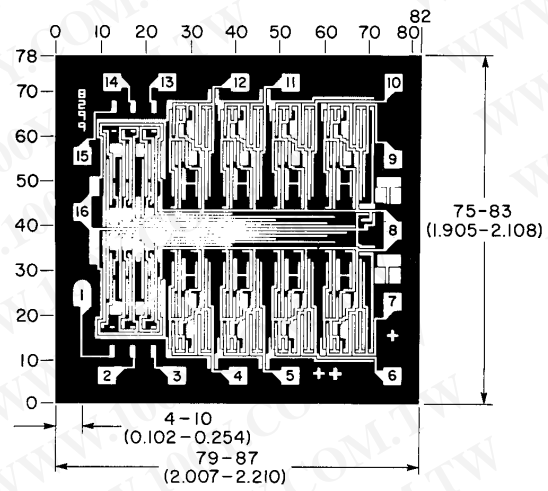

CD4556BMSH

Dimensions in parenthesis are in millimeters and are derived from the basic inch dimensions as indicated. Grid graduations are in mils (10-3 inch).

METALLIZATION: Thickness: 11kÅ - 14kÅ, AL.

PASSIVATION: 10.4kÅ - 15.6kÅ, Silane

BOND PADS: 0.004 inches X 0.004 inches MIN

DIE THICKNESS: 0.0198 inches - 0.0218 inches

CD4555BMS, CD4556BMS

勝特力材料 886-3-5753170
勝特力电子(上海) 86-21-34970699
勝特力电子(深圳) 86-755-83298787
[Http://www.100y.com.tw](http://www.100y.com.tw)

All Intersil semiconductor products are manufactured, assembled and tested under **ISO9000** quality systems certification.

Intersil products are sold by description only. Intersil Corporation reserves the right to make changes in circuit design and/or specifications at any time without notice. Accordingly, the reader is cautioned to verify that data sheets are current before placing orders. Information furnished by Intersil is believed to be accurate and reliable. However, no responsibility is assumed by Intersil or its subsidiaries for its use; nor for any infringements of patents or other rights of third parties which may result from its use. No license is granted by implication or otherwise under any patent or patent rights of Intersil or its subsidiaries.

For information regarding Intersil Corporation and its products, see web site <http://www.intersil.com>

Sales Office Headquarters

NORTH AMERICA

Intersil Corporation
P. O. Box 883, Mail Stop 53-204
Melbourne, FL 32902
TEL: (321) 724-7000
FAX: (321) 724-7240

EUROPE

Intersil SA
Mercure Center
100, Rue de la Fusee
1130 Brussels, Belgium
TEL: (32) 2.724.2111
FAX: (32) 2.724.22.05

ASIA

Intersil (Taiwan) Ltd.
Taiwan Limited
7F-6, No. 101 Fu Hsing North Road
Taipei, Taiwan
Republic of China
TEL: (886) 2 2716 9310
FAX: (886) 2 2715 3029