

256K (32K x 8-bit) UV and OTP EPROM

DESCRIPTION

The Hitachi HN27C256H is a 256-Kilobit Ultraviolet Erasable and One-Time Programmable Electrically Programmable Read Only Memory organized as 32,768 x 8-bits.

The HN27C256H features fast address access times and low power dissipation. This combination makes the HN27C256H suitable for high speed microcomputer systems. The HN27C256H also offers high speed programming.

Hitachi's HN27C256H is offered in JEDEC-Standard Byte-Wide EPROM pinouts in 28-pin Ceramic and Plastic DIP and 28-lead Plastic SOP packages.

The Ceramic DIP package is erasable by exposure to Ultraviolet light. The Plastic DIP and SOP packaged devices are One-Time Programmable and once programmed, can not be rewritten.

FEATURES

- Fast Access Times:
70 ns/85 ns/100 ns (max)
- Single Power Supply:
 $V_{CC} = 5\text{ V} \pm 10\%$
- Low Power Dissipation:
Active Mode: 30 mW/MHz (typ)
Standby Mode: 15 mA (max)
- High Speed Programming
- Programming Power Supply:
 $V_{PP} = 12.5\text{ V} \pm 0.5\text{ V}$
- Pin Arrangement:
JEDEC Standard Byte-Wide EPROM
- Packages:
28-pin Ceramic DIP
28-pin Plastic DIP
28-lead Plastic SOP

ORDERING INFORMATION

Type No.	Access Time	Package
HN27C256HG-70	70 ns	28-pin Ceramic DIP
HN27C256HG-85	85 ns	(DG-28)
HN27C256HP-85	85 ns	28-pin Plastic DIP
HN27C256HP-10	100 ns	(DP-28)
HN27C256HFP-85T	85 ns	28-lead Plastic SOP
HN27C256HFP-10T	100 ns	(FP-28DA)

勝特力材料 886-3-5753170
 勝特力电子(上海) 86-21-34970699
 勝特力电子(深圳) 86-755-83298787
[Http://www.100y.com.tw](http://www.100y.com.tw)

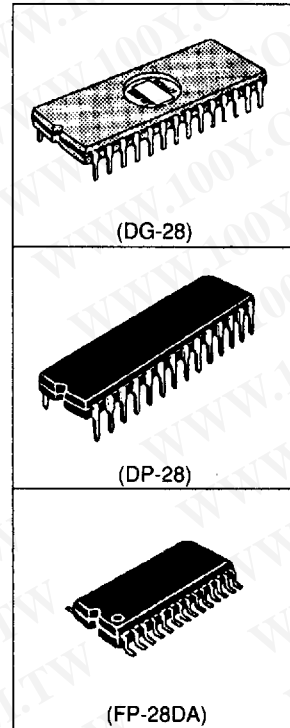

PIN ARRANGEMENT

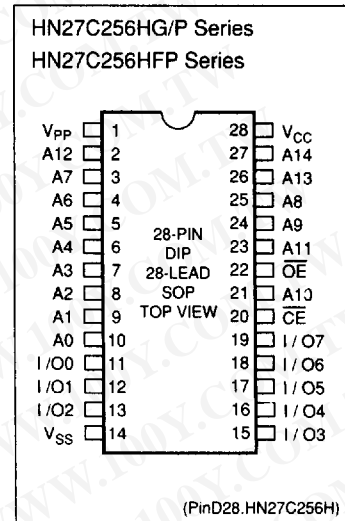

4

HN27C256H Series

PIN DESCRIPTION

Pin Name	Function
$A_0 - A_{14}$	Address
$I/O_0 - I/O_7$	Input/Output
\overline{CE}	Chip Enable
\overline{OE}	Output Enable
V_{CC}	Power Supply
V_{PP}	Programming Supply
V_{SS}	Ground

勝特力材料 886-3-5753170
 勝特力电子(上海) 86-21-34970699
 勝特力电子(深圳) 86-755-83298787
[Http://www.100y.com.tw](http://www.100y.com.tw)

BLOCK DIAGRAM

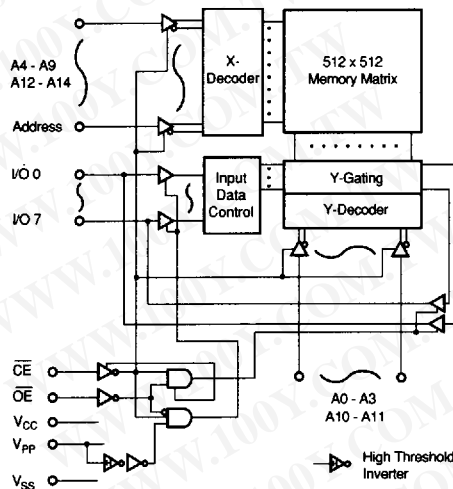

(BD.HN27C256H)

MODE SELECTION

Mode	V_{PP}	V_{CC}	\overline{CE}	\overline{OE}	A_9	I/O
Read	V_{CC}	V_{CC}	V_{IL}	V_{IL}	X ¹	D_{OUT}
Output Disable	V_{CC}	V_{CC}	V_{IL}	V_{IH}	X	High-Z
Standby	V_{CC}	V_{CC}	V_{IH}	X	X	High-Z
Program	V_{PP}	V_{CC}	V_{IL}	V_{IH}	X	D_{IN}
Program Verify	V_{PP}	V_{CC}	V_{IH}	V_{IL}	X	D_{OUT}
Optional Verify	V_{PP}	V_{CC}	V_{IL}	V_{IL}	X	D_{OUT}
Program Inhibit	V_{PP}	V_{CC}	V_{IH}	V_{IH}	X	High-Z
Identifier	V_{CC}	V_{CC}	V_{IL}	V_{IL}	V_H^2	ID

- Notes: 1. X = Don't Care.
 2. $11.5\text{ V} \leq V_H \leq 12.5\text{ V}$

■ ABSOLUTE MAXIMUM RATINGS

Item	Symbol	Value	Unit
Supply Voltage ¹	V _{CC}	-0.6 to +7.0	V
Programming Voltage ¹	V _{PP}	-0.6 to +13.5	V
All Input and Output Voltage ^{1,2}	V _{IN} , V _{OUT}	-0.6 to +7.0	V
A ₉ Input Voltage ²	V _{ID}	-0.6 to +13.5	V
Operating Temperature Range	T _{OPR}	0 to +70	°C
Storage Temperature Range	T _{STG}	-65 to +125 ³ -55 to +125 ⁴	°C
Storage Temperature Under Bias	T _{BIAS}	-10 to +80	°C

- Notes: 1. Relative to V_{SS}.
 2. V_{IN}, V_{OUT}, and V_{ID} min = -1.0V for pulse width ≤ 50 ns.
 3. HN27C256HG.
 4. HN27C256HP and HN27C256HFP.

■ CAPACITANCE (T_a = 25°C, f = 1MHz)

Item	Symbol	Typ.	Max.	Unit	Test Condition
Input Capacitance	C _{IN}	4	8	pF	V _{IN} = 0V
Output Capacitance	C _{OUT}	8	12	pF	V _{OUT} = 0V

■ DC ELECTRICAL CHARACTERISTICS FOR READ OPERATION

(V_{CC} = 5V ± 10%, V_{PP} = V_{SS} to V_{CC}, T_a = 0 to 70°C)

Item	Symbol	Min.	Typ.	Max.	Unit	Test Condition
Input Leakage Current	I _{LI}	-	-	2	μA	V _{IN} = 0 V to V _{CC}
Output Leakage Current	I _{LO}	-	-	2	μA	V _{OUT} = 0 V to V _{CC}
Operating V _{CC} Current	I _{CC1}	-	-	30	mA	I _{OUT} = 0 mA, $\overline{CE} = V_{IL}$
	I _{CC2}	-	-	40	mA	I _{OUT} = 0 mA, f = 11.8 MHz
	I _{CC3}	-	5	15	mA	I _{OUT} = 0 mA, f = 1 MHz
Standby V _{CC} Current	I _{SB}	-	-	15	mA	$\overline{CE} = V_{IH}$
V _{PP} Current	I _{PP1}	-	1	100	μA	V _{PP} = 5.5 V
Input Voltage	V _{IH}	2.2	-	V _{CC} + 1 ²	V	
	V _{IL}	-0.3 ¹	-	0.8	V	
Output Voltage	V _{OH}	2.4	-	-	V	I _{OH} = -400 μA
	V _{OL}	-	-	0.45	V	I _{OL} = 2.1 mA

- Notes: 1. V_{IL} min = -1.0 V for pulse width ≤ 50 ns.
 2. V_{IH} max = V_{CC} + 1.5 V for pulse width ≤ 20 ns.
 If V_{IH} is over the specified maximum value, Read operation can not be guaranteed.

4

勝特力材料 886-3-5753170
 勝特力电子(上海) 86-21-34970699
 勝特力电子(深圳) 86-755-83298787
 Http://www.100y.com.tw

HN27C256H Series

AC ELECTRICAL CHARACTERISTICS FOR READ OPERATION

($V_{CC} = 5V \pm 10\%$, $V_{PP} = V_{CC}$, $T_a = 0$ to 70°C)

Test Conditions

- Input pulse levels: 0.45 V / 2.4 V
- Input rise and fall times: ≤ 10 ns
- Output load: 1 TTL Gate + 100 pF (Including scope and jig)
- Reference levels for measuring timing: 1.5 V / 1.5V

Item	Symbol	-70		-85		-10		Unit	Test Condition
		Min.	Max.	Min.	Max.	Min.	Max.		
Address Access Time	t_{ACC}	-	70	-	85	-	100	ns	$\overline{CE} = \overline{OE} = V_{IL}$
Chip Enable Access Time	t_{CE}	-	70	-	85	-	100	ns	$\overline{OE} = V_{IL}$
Output Enable Access Time	t_{OE}	-	40	-	45	-	55	ns	$\overline{CE} = V_{IL}$
Output Disable to High-Z ¹	t_{DF}	0	30	0	30	0	35	ns	$\overline{CE} = V_{IL}$
Output Hold to Address Change	t_{OH}	5	-	5	-	5	-	ns	$\overline{CE} = \overline{OE} = V_{IL}$

Note: 1. t_{DF} is defined as the time at which the output becomes an open circuit and data is no longer driven.

READ TIMING WAVEFORM

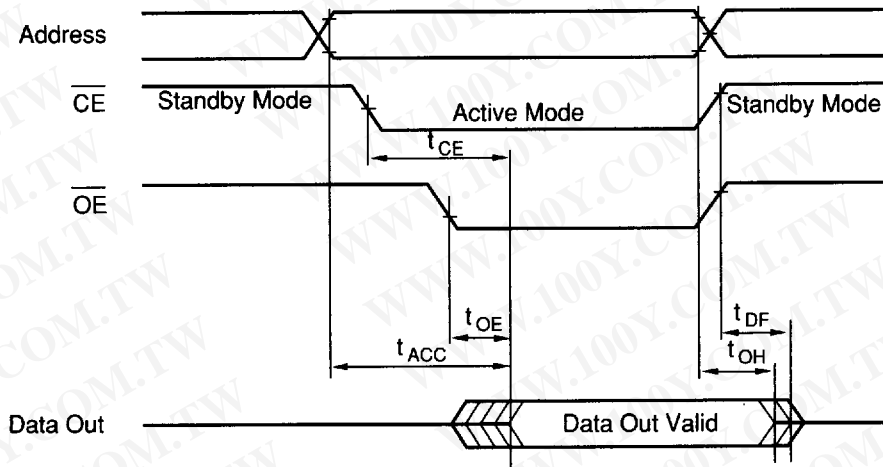

(TD.R.HN27C256H)

勝特力材料 886-3-5753170
 勝特力电子(上海) 86-21-34970699
 勝特力电子(深圳) 86-755-83298787
[Http://www.100y.com.tw](http://www.100y.com.tw)

4496203 0025369 299

HITACHI

■ DC ELECTRICAL CHARACTERISTICS FOR PROGRAMMING OPERATIONS

($V_{CC} = 6.0\text{ V} \pm 0.25\text{ V}$, $V_{PP} = 12.5\text{ V} \pm 0.5\text{ V}$, $T_a = 25\text{ }^\circ\text{C} \pm 5\text{ }^\circ\text{C}$)

Item	Symbol	Min.	Typ.	Max.	Unit	Test Condition
Input Leakage Current	I_{LI}	-	-	2	μA	$V_{IN} = 0\text{ V to } V_{CC}$
Operating V_{CC} Current	I_{CC}	-	-	30	mA	
Operating V_{PP} Current	I_{PP}	-	-	30	mA	$\overline{CE} = V_{IL}$
Input Voltage ³	V_{IH}	2.2	-	$V_{CC} + 5\text{ }^6$	V	
	V_{IL}	-0.1 ⁵	-	0.8	V	
Output Voltage	V_{OH}	2.4	-	-	V	$I_{OH} = -400\text{ }\mu\text{A}$
	V_{OL}	-	-	0.45	V	$I_{OH} = 2.1\text{ mA}$

- Notes:
- V_{CC} must be applied before V_{PP} and removed after V_{PP} .
 - V_{PP} must not exceed 13 V, including overshoot.
 - Device reliability may be adversely affected if the device is installed or removed while $V_{PP} = 12.5\text{ V}$.
 - Do not change V_{PP} from V_{IL} to 12.5 V or 12.5 V to V_{IL} when $\overline{CE} = \text{low}$.
 - V_{IL} min = -0.6 V for pulse width $\leq 20\text{ ns}$.
 - If V_{IH} is over the specified maximum value, programming operation can not be guaranteed.

■ AC ELECTRICAL CHARACTERISTICS FOR PROGRAMMING OPERATIONS

($V_{CC} = 6.0\text{ V} \pm 0.25\text{ V}$, $V_{PP} = 12.5\text{ V} \pm 0.5\text{ V}$, $T_a = 25\text{ }^\circ\text{C} \pm 5\text{ }^\circ\text{C}$)

Test Conditions

- Input pulse levels: 0.45 V / 2.4 V
- Input rise and fall times: $\leq 20\text{ ns}$
- Reference levels for measuring timing: 0.8 V / 2.0V

Item	Symbol	Min.	Typ.	Max.	Unit	Test Condition
Address Setup Time	t_{AS}	2	-	-	μs	
Address Hold Time	t_{AH}	0	-	-	μs	
Data Setup Time	t_{DS}	2	-	-	μs	
V_{PP} Setup Time	t_{VPS}	2	-	-	μs	
V_{CC} Setup Time	t_{VCS}	2	-	-	μs	
Output Enable Setup Time	t_{OES}	2	-	-	μs	
Output Disable Time	t_{DF}	0	-	130	ns	
\overline{CE} Initial Programming Pulse Width	t_{PW}	0.19	0.20	0.21	ms	
\overline{CE} Overprogramming Pulse Width	t_{OPW}	0.19	-	5.25	ms	
Data Valid from Output Enable Time	t_{OE}	0	-	150	ns	

- Note:
- t_{DF} is defined as the time at which the output becomes an open circuit and data is no longer driven.

勝特力材料 886-3-5753170
 勝特力电子(上海) 86-21-34970699
 勝特力电子(深圳) 86-755-83298787
[Http://www.100y.com.tw](http://www.100y.com.tw)

FAST HIGH-RELIABILITY PROGRAMMING FLOWCHART

The Hitachi HN27C256H can be programmed with the Fast High-Reliability Programming algorithm shown in the following flowchart. This algorithm provides a fast programming time without voltage stress to the device or deterioration in reliability of programmed data. This algorithm theoretically provides one-tenth the programming time of the conventional High Performance Programming algorithm.

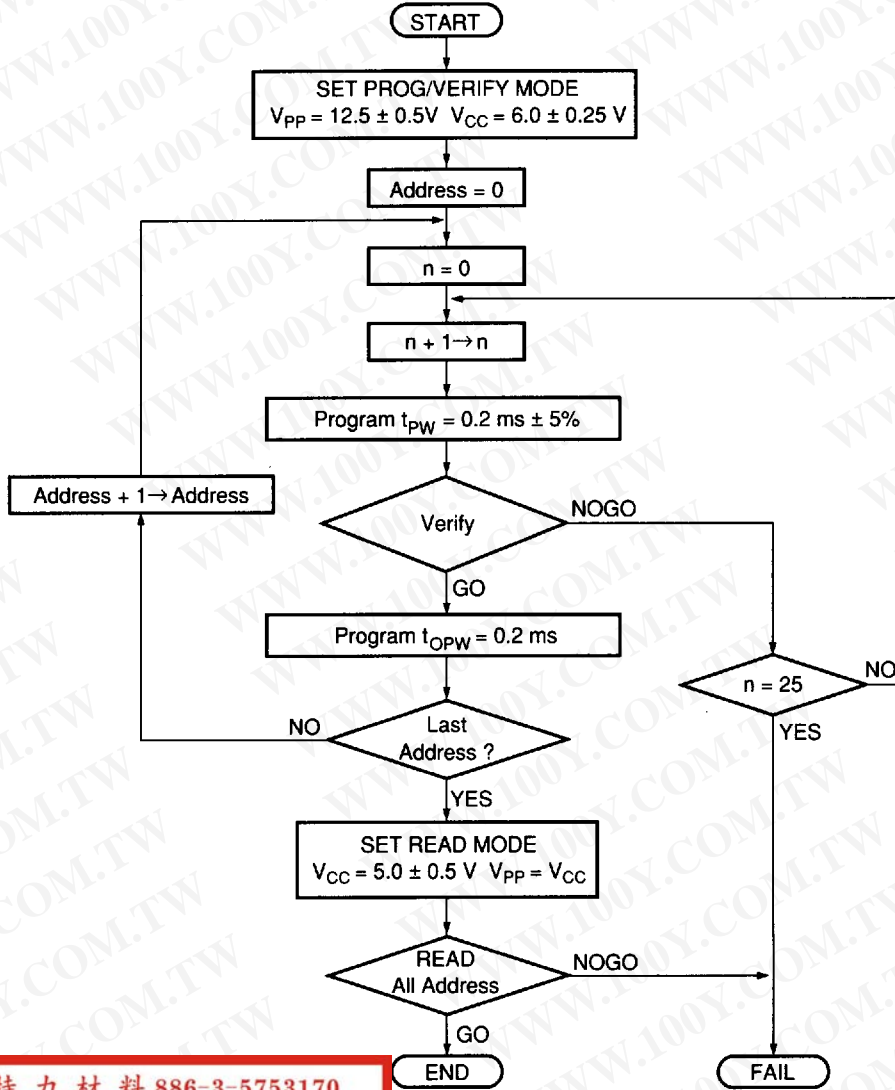

勝特力材料 886-3-5753170
 勝特力电子(上海) 86-21-34970699
 勝特力电子(深圳) 86-755-83298787
[Http://www.100y.com.tw](http://www.100y.com.tw)

(FC.P.HN27C256H)

FAST HIGH-RELIABILITY PROGRAMMING TIMING WAVEFORM

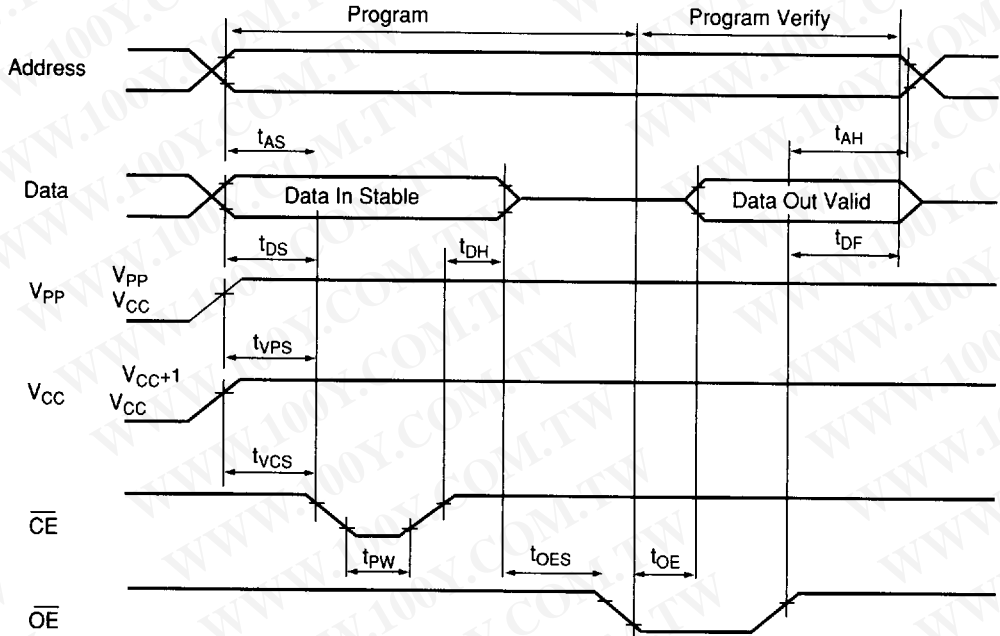

(T.D.P. HN27C256H)

勝特力材料 886-3-5753170
 勝特力电子(上海) 86-21-34970699
 勝特力电子(深圳) 86-755-83298787
[Http://www.100y.com.tw](http://www.100y.com.tw)

■ HIGH PERFORMANCE PROGRAMMING FLOWCHART

The Hitachi HN27C256H can be programmed with the High Performance Programming algorithm shown in the following flowchart. This algorithm provides a fast programming time without voltage stress to the device or deterioration in reliability of programmed data.

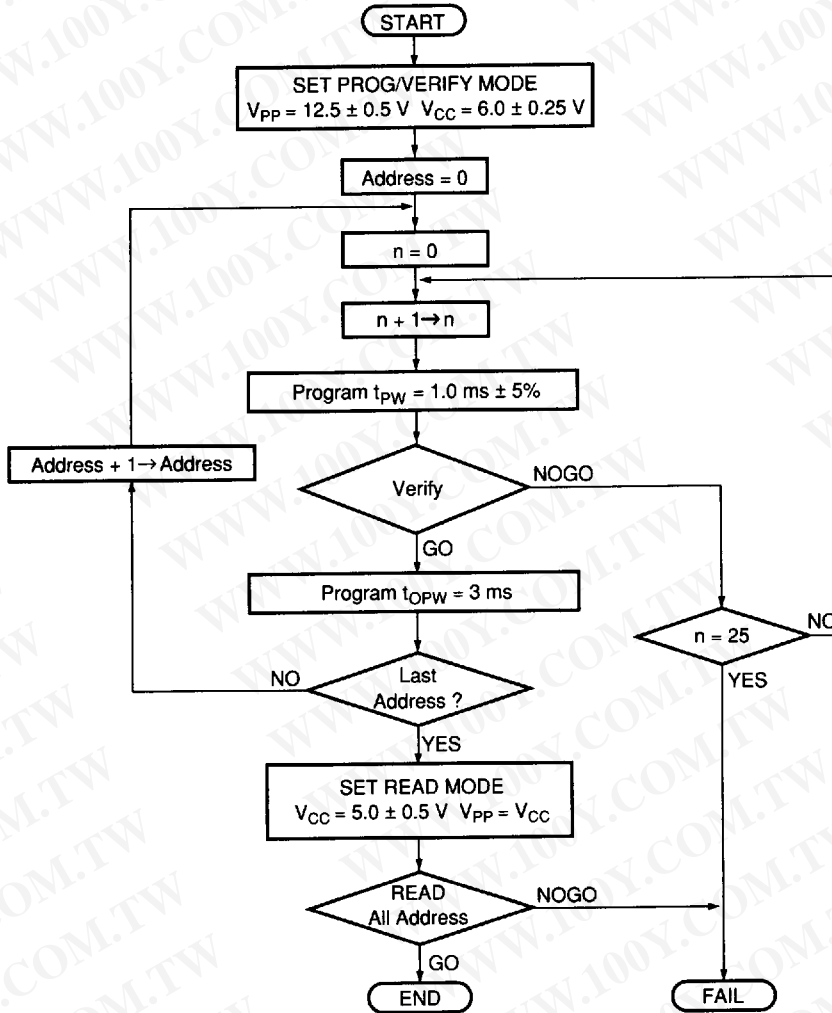

勝特力材料 886-3-5753170
 勝特力电子(上海) 86-21-34970699
 勝特力电子(深圳) 86-755-83298787
[Http://www.100y.com.tw](http://www.100y.com.tw)

(FC.PP.HN27C256H)

■ HIGH PERFORMANCE PROGRAMMING TIMING WAVEFORM

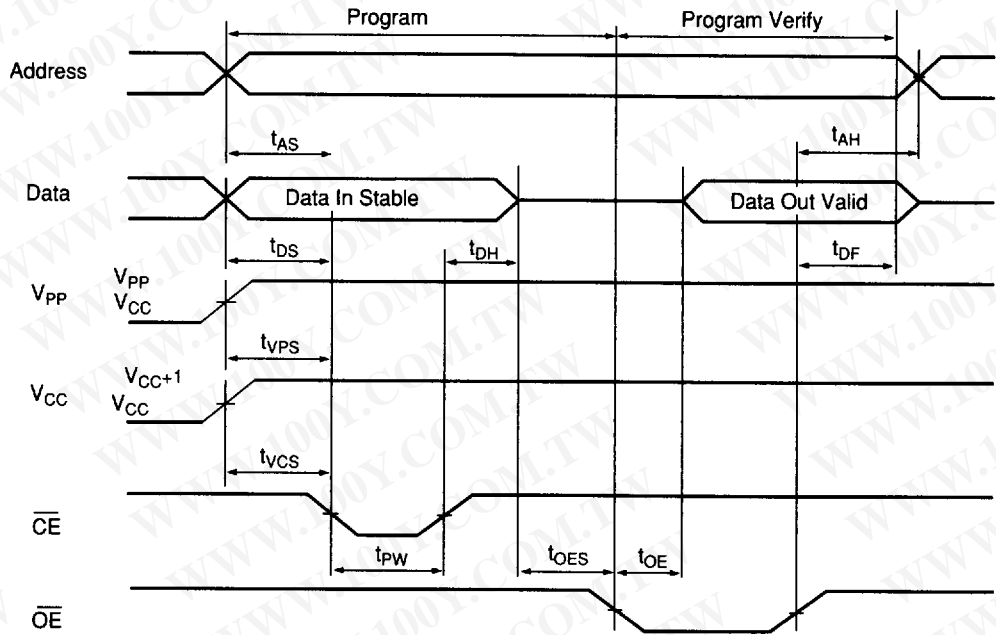

(TD.PP.HN27C256H)

勝特力材料 886-3-5753170
 勝特力电子(上海) 86-21-34970699
 勝特力电子(深圳) 86-755-83298787
[Http://www.100y.com.tw](http://www.100y.com.tw)

HN27C256H Series

■ ERASING THE HN27C256H

The Hitachi HN27C256H Ceramic DIP package allow the device to be erased by exposure to ultraviolet light of 2537Å. All of the data is changed to "1" after this erasure procedure. The minimum integrated dose (UV intensity x exposure time) for erasure is 15 W-sec/cm².

■ DEVICE IDENTIFIER MODE DESCRIPTION

The Device Identifier Mode allows binary codes to be read from the outputs that identify the manufacturer and the type of device. Using this mode with programming equipment, the device will automatically match its own erase and programming algorithm.

■ HN27C256H SERIES IDENTIFIER CODE

Identifier	A ₀	I/O ₇	I/O ₆	I/O ₅	I/O ₄	I/O ₃	I/O ₂	I/O ₁	I/O ₀	Hex Data
Manufacturer Code	V _{IL}	0	0	0	0	0	1	1	1	07
Device Code	V _{IH}	0	0	1	1	0	0	0	1	31

- Notes: 1. A₉ = 12.0 V ± 0.5V
 3. A₁-A₈, A₁₀-A₁₄, \overline{CE} , \overline{OE} = V_{IL}

■ HN27C256HP/FP RECOMMENDED SCREENING CONDITIONS

Before mounting the HN27C256H plastic packages, please make the following screening (baking without bias) shown below:

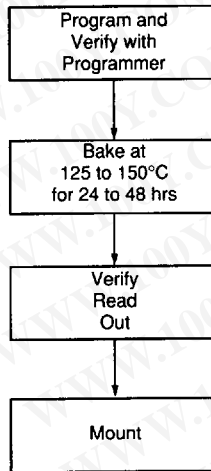

(RSC.EPROM)

勝特力材料 886-3-5753170
 勝特力电子(上海) 86-21-34970699
 勝特力电子(深圳) 86-755-83298787
[Http://www.100y.com.tw](http://www.100y.com.tw)