

MAX3221

3-V TO 5.5-V SINGLE-CHANNEL RS-232 LINE DRIVER/RECEIVER WITH ± 15 -kV ESD PROTECTION

SLLS348M – JUNE 1999 – REVISED MARCH 2004

- **RS-232 Bus-Pin ESD Protection Exceeds ± 15 kV Using Human-Body Model (HBM)**
- **Meets or Exceeds the Requirements of TIA/EIA-232-F and ITU v.28 Standards**
- **Operates With 3-V to 5.5-V V_{CC} Supply**
- **Operates Up To 250 kbit/s**
- **One Driver and One Receiver**
- **Low Standby Current . . . 1 μ A Typical**
- **External Capacitors . . . 4 \times 0.1 μ F**
- **Accepts 5-V Logic Input With 3.3-V Supply**
- **Alternative High-Speed Pin-Compatible Device (1 Mbit/s)**
 - SNx5C3221
- **Auto-Powerdown Feature Automatically Disables Drivers for Power Savings**
- **Applications**
 - Battery-Powered, Hand-Held, and Portable Equipment
 - PDAs and Palmtop PCs
 - Notebooks, Subnotebooks, and Laptops
 - Digital Cameras
 - Mobile Phones and Wireless Devices

DB OR PW PACKAGE
(TOP VIEW)

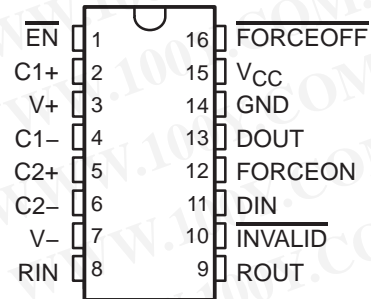

勝特力材料 886-3-5753170
 勝特力电子(上海) 86-21-34970699
 勝特力电子(深圳) 86-755-83298787
[Http://www.100y.com.tw](http://www.100y.com.tw)

description/ordering information

The MAX3221 consists of one line driver, one line receiver, and a dual charge-pump circuit with ± 15 -kV ESD protection pin to pin (serial-port connection pins, including GND). The device meets the requirements of TIA/EIA-232-F and provides the electrical interface between an asynchronous communication controller and the serial-port connector. The charge pump and four small external capacitors allow operation from a single 3-V to 5.5-V supply. These devices operate at data signaling rates up to 250 kbit/s and a maximum of 30-V/ μ s driver output slew rate.

ORDERING INFORMATION

TA	PACKAGE†	ORDERABLE PART NUMBER	TOP-SIDE MARKING
–0°C to 70°C	SSOP (DB)	Tube of 80	MAX3221CDB
		Reel of 2000	MAX3221CDBR
	TSSOP (PW)	Tube of 90	MAX3221CPW
		Reel of 2000	MAX3221CPWR
–40°C to 85°C	SSOP (DB)	Tube of 80	MAX3221IDB
		Reel of 2000	MAX3221IDBR
	TSSOP (PW)	Tube of 90	MAX3221IPW
		Reel of 2000	MAX3221IPWR

† Package drawings, standard packing quantities, thermal data, symbolization, and PCB design guidelines are available at www.ti.com/sc/package.



Please be aware that an important notice concerning availability, standard warranty, and use in critical applications of Texas Instruments semiconductor products and disclaimers thereto appears at the end of this data sheet.

PRODUCTION DATA information is current as of publication date. Products conform to specifications per the terms of Texas Instruments standard warranty. Production processing does not necessarily include testing of all parameters.



POST OFFICE BOX 655303 • DALLAS, TEXAS 75265

Copyright © 2004, Texas Instruments Incorporated

MAX3221

3-V TO 5.5-V SINGLE-CHANNEL RS-232 LINE DRIVER/RECEIVER WITH ±15-kV ESD PROTECTION

SLLS348M – JUNE 1999 – REVISED MARCH 2004

description/ordering information (continued)

Flexible control options for power management are available when the serial port is inactive. The auto-powerdown feature functions when FORCEON is low and FORCEOFF is high. During this mode of operation, if the device does not sense a valid RS-232 signal on the receiver input, the driver output is disabled. If FORCEOFF is set low and EN is high, both the driver and receiver are shut off, and the supply current is reduced to 1 µA. Disconnecting the serial port or turning off the peripheral drivers causes the auto-powerdown condition to occur. Auto-powerdown can be disabled when FORCEON and FORCEOFF are high. With auto-powerdown enabled, the device is activated automatically when a valid signal is applied to the receiver input. The INVALID output notifies the user if an RS-232 signal is present at the receiver input. INVALID is high (valid data) if the receiver input voltage is greater than 2.7 V or less than -2.7 V, or has been between -0.3 V and 0.3 V for less than 30 µs. INVALID is low (invalid data) if the receiver input voltage is between -0.3 V and 0.3 V for more than 30 µs. Refer to Figure 5 for receiver input levels.

Function Tables

EACH DRIVER

INPUTS				OUTPUT DOUT	DRIVER STATUS
DIN	FORCEON	FORCEOFF	VALID RIN RS-232 LEVEL		
X	X	L	X	Z	Powered off
L	H	H	X	H	Normal operation with auto-powerdown disabled
H	H	H	X	L	
L	L	H	Yes	H	Normal operation with auto-powerdown enabled
H	L	H	Yes	L	
L	L	H	No	Z	Powered off by auto-powerdown feature
H	L	H	No	Z	

H = high level, L = low level, X = irrelevant, Z = high impedance

EACH RECEIVER

INPUTS			OUTPUT ROUT
RIN	EN	VALID RIN RS-232 LEVEL	
L	L	X	H
H	L	X	L
X	H	X	Z
Open	L	No	H

H = high level, L = low level, X = irrelevant, Z = high impedance (off), Open = disconnected input or connected driver off

勝特力材料 886-3-5753170
勝特力电子(上海) 86-21-34970699
勝特力电子(深圳) 86-755-83298787
[Http://www.100y.com.tw](http://www.100y.com.tw)

MAX3221

3-V TO 5.5-V SINGLE-CHANNEL RS-232 LINE DRIVER/RECEIVER WITH ± 15 -kV ESD PROTECTION

SLLS348M – JUNE 1999 – REVISED MARCH 2004

logic diagram (positive logic)

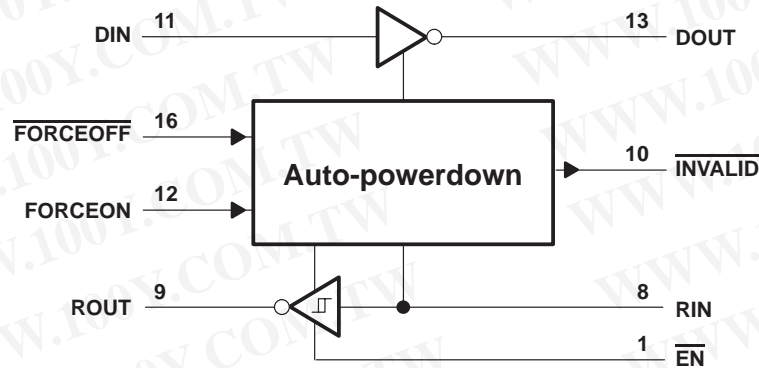

absolute maximum ratings over operating free-air temperature range (unless otherwise noted)†

Supply voltage range, V_{CC} (see Note 1)	–0.3 V to 6 V
Positive output supply voltage range, $V+$ (see Note 1)	–0.3 V to 7 V
Negative output supply voltage range, $V-$ (see Note 1)	0.3 V to –7 V
Supply voltage difference, $V+ - V-$ (see Note 1)	13 V
Input voltage range, V_I : Driver ($\overline{\text{FORCEOFF}}$, FORCEON , $\overline{\text{EN}}$)	–0.3 V to 6 V
Receiver	–25 V to 25 V
Output voltage range, V_O : Driver	–13.2 V to 13.2 V
Receiver ($\overline{\text{INVALID}}$)	–0.3 V to $V_{CC} + 0.3$ V
Package thermal impedance, θ_{JA} (see Notes 2 and 3): DB package	82°C/W
PW package	108°C/W
Operating virtual junction temperature, T_J	150°C
Storage temperature range, T_{Stg}	–65°C to 150°C

† Stresses beyond those listed under “absolute maximum ratings” may cause permanent damage to the device. These are stress ratings only, and functional operation of the device at these or any other conditions beyond those indicated under “recommended operating conditions” is not implied. Exposure to absolute-maximum-rated conditions for extended periods may affect device reliability.

NOTES: 1. All voltages are with respect to network GND.

- Maximum power dissipation is a function of $T_J(\text{max})$, θ_{JA} , and T_A . The maximum allowable power dissipation at any allowable ambient temperature is $P_D = (T_J(\text{max}) - T_A)/\theta_{JA}$. Operating at the absolute maximum T_J of 150°C can affect reliability.
- The package thermal impedance is calculated in accordance with JESD 51-7.

recommended operating conditions (see Note 4 and Figure 6)

		MIN	NOM	MAX	UNIT	
Supply voltage	$V_{CC} = 3.3$ V	3	3.3	3.6	V	
	$V_{CC} = 5$ V	4.5	5	5.5		
V_{IH} Driver and control high-level input voltage	DIN , $\overline{\text{FORCEOFF}}$, FORCEON , $\overline{\text{EN}}$	$V_{CC} = 3.3$ V		2	V	
		$V_{CC} = 5$ V		2.4		
V_{IL} Driver and control low-level input voltage	DIN , $\overline{\text{FORCEOFF}}$, FORCEON , $\overline{\text{EN}}$				0.8	V
V_I Driver and control input voltage	DIN , $\overline{\text{FORCEOFF}}$, FORCEON	0			5.5	V
V_I Receiver input voltage		–25			25	V
T_A Operating free-air temperature	MAX3221C	0		70	°C	
	MAX3221I	–40		85		

NOTE 4: Test conditions are $C1-C4 = 0.1 \mu\text{F}$ at $V_{CC} = 3.3 \text{ V} \pm 0.3 \text{ V}$; $C1 = 0.047 \mu\text{F}$, $C2-C4 = 0.33 \mu\text{F}$ at $V_{CC} = 5 \text{ V} \pm 0.5 \text{ V}$.

勝特力材料 886-3-5753170
 勝特力电子(上海) 86-21-34970699
 勝特力电子(深圳) 86-755-83298787
[Http://www.100y.com.tw](http://www.100y.com.tw)



MAX3221

3-V TO 5.5-V SINGLE-CHANNEL RS-232 LINE DRIVER/RECEIVER WITH ± 15 -kV ESD PROTECTION

SLLS348M – JUNE 1999 – REVISED MARCH 2004

electrical characteristics over recommended ranges of supply voltage and operating free-air temperature (unless otherwise noted) (see Note 4 and Figure 6)

PARAMETER		TEST CONDITIONS		MIN	TYP†	MAX	UNIT
I_I	Input leakage current	FORCEOFF, FORCEON, EN			± 0.01	± 1	μA
I_{CC}	Supply current	Auto-powerdown disabled	$V_{CC} = 3.3\text{ V or } 5\text{ V, } T_A = 25^\circ\text{C}$	No load, FORCEOFF and FORCEON at V_{CC}	0.3	1	mA
		Powered off		No load, FORCEOFF at GND	1	10	μA
		Auto-powerdown enabled		No load, FORCEOFF at V_{CC} , FORCEON at GND, All RIN are open or grounded	1	10	

† All typical values are at $V_{CC} = 3.3\text{ V}$ or $V_{CC} = 5\text{ V}$, and $T_A = 25^\circ\text{C}$.

NOTE 4: Test conditions are C_1 – $C_4 = 0.1\ \mu\text{F}$ at $V_{CC} = 3.3\text{ V} \pm 0.3\text{ V}$; $C_1 = 0.047\ \mu\text{F}$, C_2 – $C_4 = 0.33\ \mu\text{F}$ at $V_{CC} = 5\text{ V} \pm 0.5\text{ V}$.

DRIVER SECTION

electrical characteristics over recommended ranges of supply voltage and operating free-air temperature (unless otherwise noted) (see Note 4 and Figure 6)

PARAMETER		TEST CONDITIONS		MIN	TYP†	MAX	UNIT
V_{OH}	High-level output voltage	DOUT at $R_L = 3\text{ k}\Omega$ to GND,	DIN = GND	5	5.4		V
V_{OL}	Low-level output voltage	DOUT at $R_L = 3\text{ k}\Omega$ to GND,	DIN = V_{CC}	–5	–5.4		V
I_{IH}	High-level input current	$V_I = V_{CC}$		± 0.01		± 1	μA
I_{IL}	Low-level input current	V_I at GND		± 0.01		± 1	μA
I_{OS}	Short-circuit output current‡	$V_{CC} = 3.6\text{ V, } V_O = 0\text{ V}$		± 35		± 60	mA
		$V_{CC} = 5.5\text{ V, } V_O = 0\text{ V}$		± 35		± 60	
r_o	Output resistance	$V_{CC}, V_+, \text{ and } V_- = 0\text{ V, } V_O = \pm 2\text{ V}$		300	10M		Ω
I_{off}	Output leakage current	FORCEOFF = GND	$V_O = \pm 12\text{ V, } V_{CC} = 3\text{ V to } 3.6\text{ V}$			± 25	μA
			$V_O = \pm 10\text{ V, } V_{CC} = 4.5\text{ V to } 5.5\text{ V}$			± 25	

† All typical values are at $V_{CC} = 3.3\text{ V}$ or $V_{CC} = 5\text{ V}$, and $T_A = 25^\circ\text{C}$.

‡ Short-circuit durations should be controlled to prevent exceeding the device absolute power-dissipation ratings, and not more than one output should be shorted at a time.

NOTE 4: Test conditions are C_1 – $C_4 = 0.1\ \mu\text{F}$ at $V_{CC} = 3.3\text{ V} \pm 0.3\text{ V}$; $C_1 = 0.047\ \mu\text{F}$, C_2 – $C_4 = 0.33\ \mu\text{F}$ at $V_{CC} = 5\text{ V} \pm 0.5\text{ V}$.

switching characteristics over recommended ranges of supply voltage and operating free-air temperature (unless otherwise noted) (see Note 4 and Figure 6)

PARAMETER		TEST CONDITIONS		MIN	TYP†	MAX	UNIT
	Maximum data rate	$C_L = 1000\text{ pF, } R_L = 3\text{ k}\Omega,$	See Figure 1	150	250		kbit/s
$t_{sk(p)}$	Pulse skew§	$C_L = 150\text{ pF to } 2500\text{ pF, } R_L = 3\text{ k}\Omega \text{ to } 7\text{ k}\Omega,$	See Figure 2		100		ns
SR(tr)	Slew rate, transition region (see Figure 1)	$V_{CC} = 3.3\text{ V, } R_L = 3\text{ k}\Omega \text{ to } 7\text{ k}\Omega$	$C_L = 150\text{ pF to } 1000\text{ pF}$	6		30	V/ μs
			$C_L = 150\text{ pF to } 2500\text{ pF}$	4		30	

† All typical values are at $V_{CC} = 3.3\text{ V}$ or $V_{CC} = 5\text{ V}$, and $T_A = 25^\circ\text{C}$.

§ Pulse skew is defined as $|t_{pLH} - t_{pHL}|$ of each channel of the same device.

NOTE 4: Test conditions are C_1 – $C_4 = 0.1\ \mu\text{F}$ at $V_{CC} = 3.3\text{ V} \pm 0.3\text{ V}$; $C_1 = 0.047\ \mu\text{F}$, C_2 – $C_4 = 0.33\ \mu\text{F}$ at $V_{CC} = 5\text{ V} \pm 0.5\text{ V}$.

勝特力材料 886-3-5753170
 勝特力电子(上海) 86-21-34970699
 勝特力电子(深圳) 86-755-83298787
[Http://www.100y.com.tw](http://www.100y.com.tw)



MAX3221
3-V TO 5.5-V SINGLE-CHANNEL RS-232 LINE DRIVER/RECEIVER
WITH ±15-kV ESD PROTECTION

SLLS348M – JUNE 1999 – REVISED MARCH 2004

ESD protection

TERMINAL		TEST CONDITIONS	TYP	UNIT
NAME	NO.			
DOUT	13	HBM	±15	kV

RECEIVER SECTION

electrical characteristics over recommended ranges of supply voltage and operating free-air temperature (unless otherwise noted) (see Note 4 and Figure 6)

PARAMETER		TEST CONDITIONS	MIN	TYP†	MAX	UNIT
V _{OH}	High-level output voltage	I _{OH} = -1 mA	V _{CC} -0.6	V _{CC} -0.1		V
V _{OL}	Low-level output voltage	I _{OL} = 1.6 mA			0.4	V
V _{IT+}	Positive-going input threshold voltage	V _{CC} = 3.3 V		1.6	2.4	V
		V _{CC} = 5 V		1.9	2.4	
V _{IT-}	Negative-going input threshold voltage	V _{CC} = 3.3 V	0.6	1.1		V
		V _{CC} = 5 V	0.8	1.4		
V _{hys}	Input hysteresis (V _{IT+} - V _{IT-})			0.5		V
I _{off}	Output leakage current	FORCEOFF = 0 V		±0.05	±10	µA
r _i	Input resistance	V _I = ±3 V to ±25 V	3	5	7	kΩ

† All typical values are at V_{CC} = 3.3 V or V_{CC} = 5 V, and T_A = 25°C.

NOTE 4: Test conditions are C1-C4 = 0.1 µF at V_{CC} = 3.3 V ± 0.3 V; C1 = 0.047 µF, C2-C4 = 0.33 µF at V_{CC} = 5 V ± 0.5 V.

switching characteristics over recommended ranges of supply voltage and operating free-air temperature (unless otherwise noted) (see Note 4)

PARAMETER		TEST CONDITIONS	MIN	TYP†	MAX	UNIT
t _{PLH}	Propagation delay time, low- to high-level output	C _L = 150 pF, See Figure 3		150		ns
t _{PHL}	Propagation delay time, high- to low-level output	C _L = 150 pF, See Figure 3		150		ns
t _{en}	Output enable time	C _L = 150 pF, R _L = 3 kΩ, See Figure 4		200		ns
t _{dis}	Output disable time	C _L = 150 pF, R _L = 3 kΩ, See Figure 4		200		ns
t _{sk(p)}	Pulse skew‡	See Figure 3		50		ns

† All typical values are at V_{CC} = 3.3 V or V_{CC} = 5 V, and T_A = 25°C.

‡ Pulse skew is defined as |t_{PLH} - t_{PHL}| of each channel of the same device.

NOTE 4: Test conditions are C1-C4 = 0.1 µF at V_{CC} = 3.3 V ± 0.3 V; C1 = 0.047 µF, C2-C4 = 0.33 µF at V_{CC} = 5 V ± 0.5 V.

ESD protection

TERMINAL		TEST CONDITIONS	TYP	UNIT
NAME	NO.			
RIN	8	HBM	±15	kV

勝特力材料 886-3-5753170
 勝特力电子(上海) 86-21-34970699
 勝特力电子(深圳) 86-755-83298787
[Http://www.100y.com.tw](http://www.100y.com.tw)



MAX3221**3-V TO 5.5-V SINGLE-CHANNEL RS-232 LINE DRIVER/RECEIVER
WITH ± 15 -kV ESD PROTECTION**

SLLS348M – JUNE 1999 – REVISED MARCH 2004

AUTO-POWERDOWN SECTION

electrical characteristics over recommended ranges of supply voltage and operating free-air temperature (unless otherwise noted) (see Figure 5)

PARAMETER		TEST CONDITIONS	MIN	MAX	UNIT
V _{T+} (valid)	Receiver input threshold for $\overline{\text{INVALID}}$ high-level output voltage	FORCEON = GND, $\overline{\text{FORCEOFF}} = V_{CC}$		2.7	V
V _{T-} (valid)	Receiver input threshold for $\overline{\text{INVALID}}$ high-level output voltage	FORCEON = GND, $\overline{\text{FORCEOFF}} = V_{CC}$	-2.7		V
V _T (invalid)	Receiver input threshold for $\overline{\text{INVALID}}$ low-level output voltage	FORCEON = GND, $\overline{\text{FORCEOFF}} = V_{CC}$	-0.3	0.3	V
V _{OH}	$\overline{\text{INVALID}}$ high-level output voltage	I _{OH} = -1 mA, FORCEON = GND, $\overline{\text{FORCEOFF}} = V_{CC}$	V _{CC} -0.6		V
V _{OL}	$\overline{\text{INVALID}}$ low-level output voltage	I _{OL} = 1.6 mA, FORCEON = GND, $\overline{\text{FORCEOFF}} = V_{CC}$		0.4	V

switching characteristics over recommended ranges of supply voltage and operating free-air temperature (unless otherwise noted) (see Figure 5)

PARAMETER		MIN	TYP†	MAX	UNIT
t _{valid}	Propagation delay time, low- to high-level output		1		μs
t _{invalid}	Propagation delay time, high- to low-level output		30		μs
t _{en}	Supply enable time		100		μs

† All typical values are at V_{CC} = 3.3 V or V_{CC} = 5 V, and T_A = 25°C.

勝特力材料 886-3-5753170
 勝特力电子(上海) 86-21-34970699
 勝特力电子(深圳) 86-755-83298787
[Http://www.100y.com.tw](http://www.100y.com.tw)

MAX3221

3-V TO 5.5-V SINGLE-CHANNEL RS-232 LINE DRIVER/RECEIVER WITH ±15-kV ESD PROTECTION

SLLS348M – JUNE 1999 – REVISED MARCH 2004

PARAMETER MEASUREMENT INFORMATION

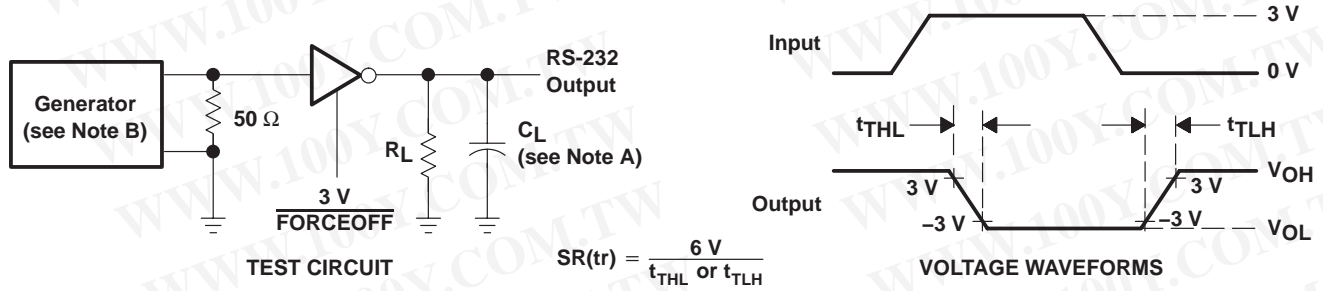

NOTES: A. C_L includes probe and jig capacitance.
B. The pulse generator has the following characteristics: PRR = 250 kbit/s, $Z_O = 50\ \Omega$, 50% duty cycle, $t_r \leq 10\text{ ns}$, $t_f \leq 10\text{ ns}$.

Figure 1. Driver Slew Rate

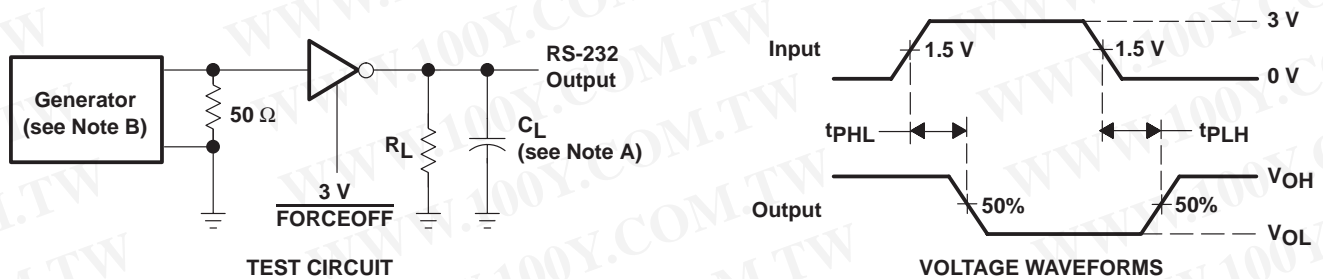

NOTES: A. C_L includes probe and jig capacitance.
B. The pulse generator has the following characteristics: PRR = 250 kbit/s, $Z_O = 50\ \Omega$, 50% duty cycle, $t_r \leq 10\text{ ns}$, $t_f \leq 10\text{ ns}$.

Figure 2. Driver Pulse Skew

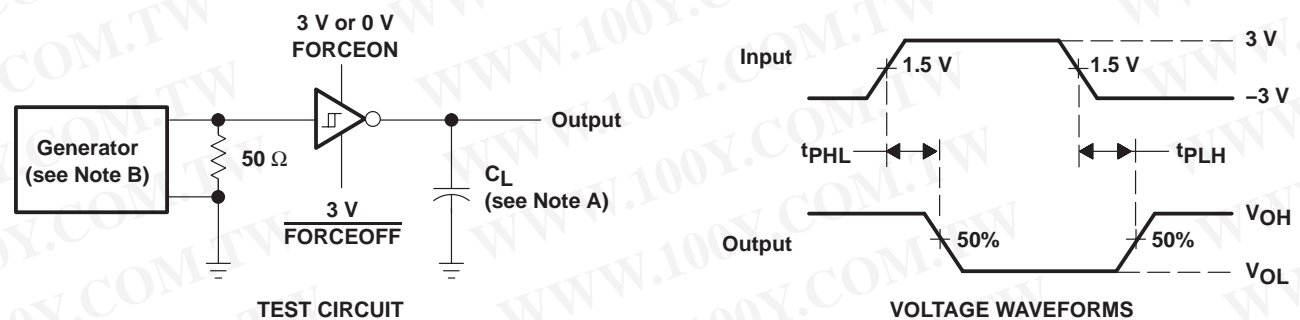

NOTES: A. C_L includes probe and jig capacitance.
B. The pulse generator has the following characteristics: $Z_O = 50\ \Omega$, 50% duty cycle, $t_r \leq 10\text{ ns}$, $t_f \leq 10\text{ ns}$.

Figure 3. Receiver Propagation Delay Times

勝特力材料 886-3-5753170
 勝特力电子(上海) 86-21-34970699
 勝特力电子(深圳) 86-755-83298787
[Http://www.100y.com.tw](http://www.100y.com.tw)

MAX3221

3-V TO 5.5-V SINGLE-CHANNEL RS-232 LINE DRIVER/RECEIVER WITH ± 15 -kV ESD PROTECTION

SLLS348M – JUNE 1999 – REVISED MARCH 2004

PARAMETER MEASUREMENT INFORMATION

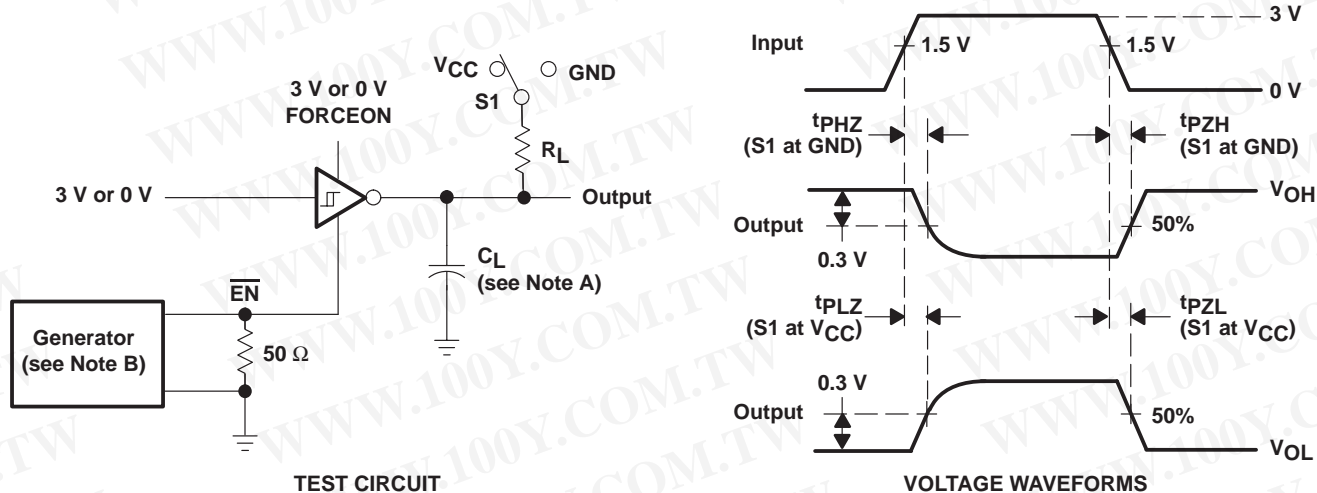

- NOTES:
- A. C_L includes probe and jig capacitance.
 - B. The pulse generator has the following characteristics: $Z_O = 50 \Omega$, 50% duty cycle, $t_r \leq 10$ ns, $t_f \leq 10$ ns.
 - C. t_{PLZ} and t_{PHZ} are the same as t_{dis} .
 - D. t_{PZL} and t_{PZH} are the same as t_{en} .

Figure 4. Receiver Enable and Disable Times

勝特力材料 886-3-5753170
勝特力电子(上海) 86-21-34970699
勝特力电子(深圳) 86-755-83298787
[Http://www.100y.com.tw](http://www.100y.com.tw)

MAX3221
3-V TO 5.5-V SINGLE-CHANNEL RS-232 LINE DRIVER/RECEIVER
WITH ± 15 -kV ESD PROTECTION

SLLS348M – JUNE 1999 – REVISED MARCH 2004

PARAMETER MEASUREMENT INFORMATION

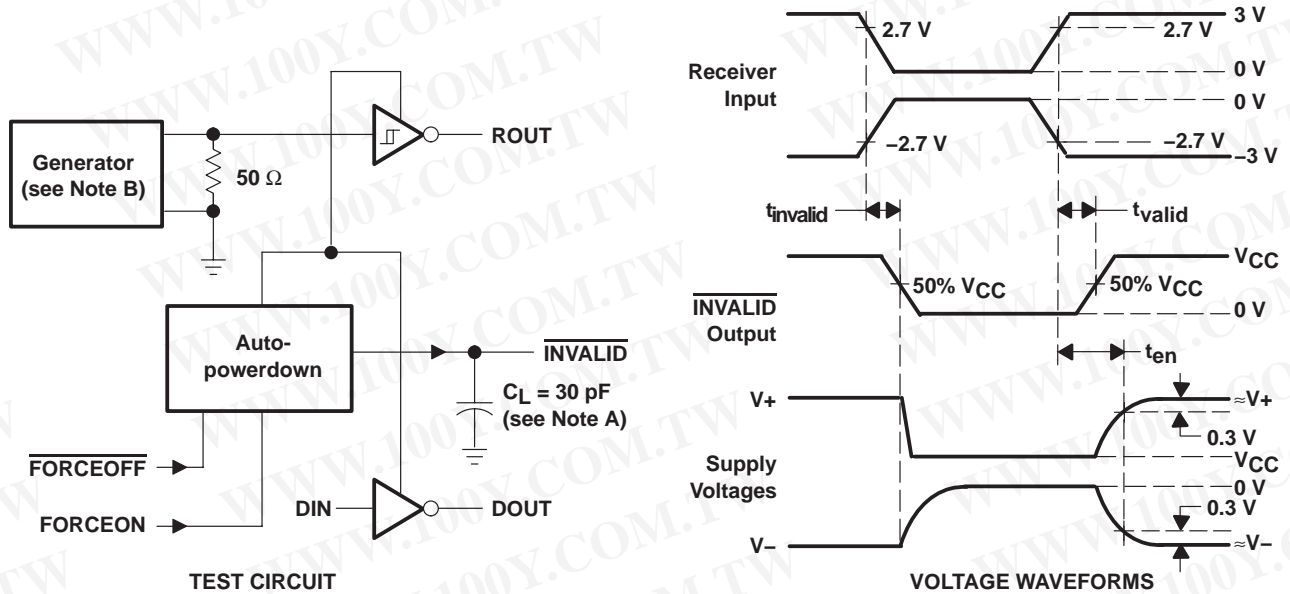

NOTES: A. C_L includes probe and jig capacitance.

B. The pulse generator has the following characteristics: PRR = 5 kbit/s, $Z_O = 50 \Omega$, 50% duty cycle, $t_r \leq 10$ ns, $t_f \leq 10$ ns.

Figure 5. $\overline{\text{INVALID}}$ Propagation Delay Times and Driver Enabling Time

勝特力材料 886-8-5753170
 勝特力电子(上海) 86-21-34970699
 勝特力电子(深圳) 86-755-83298787
[Http://www.100y.com.tw](http://www.100y.com.tw)

MAX3221

3-V TO 5.5-V SINGLE-CHANNEL RS-232 LINE DRIVER/RECEIVER WITH ±15-kV ESD PROTECTION

SLLS348M – JUNE 1999 – REVISED MARCH 2004

APPLICATION INFORMATION

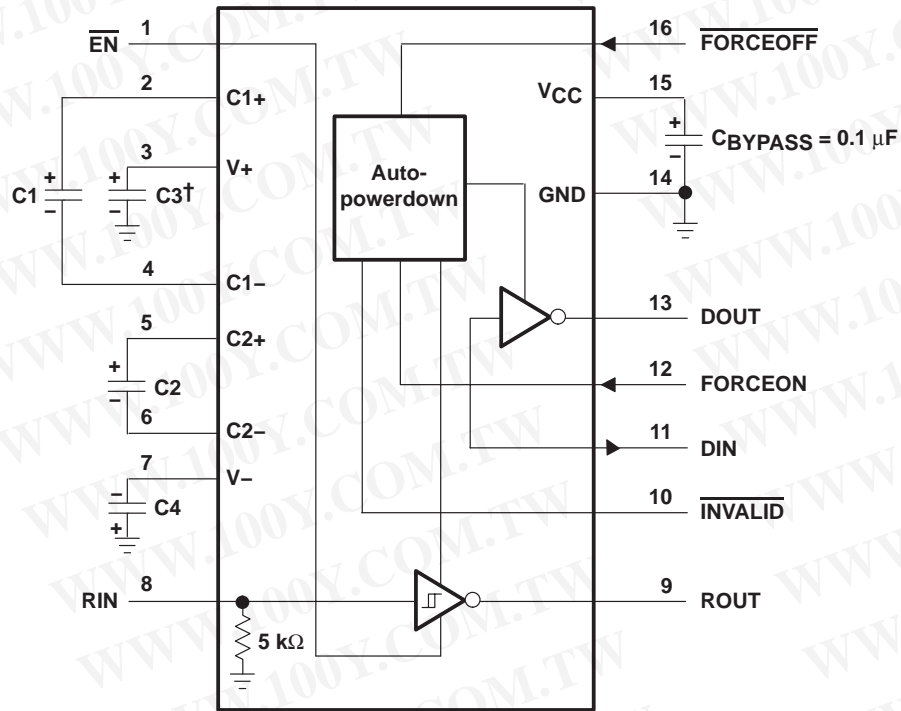

† C3 can be connected to VCC or GND.

NOTES: A. Resistor values shown are nominal.

B. Nonpolarized ceramic capacitors are acceptable. If polarized tantalum or electrolytic capacitors are used, they should be connected as shown.

VCC vs CAPACITOR VALUES

VCC	C1	C2, C3, and C4
3.3 V ± 0.3 V	0.1 μF	0.1 μF
5 V ± 0.5 V	0.047 μF	0.33 μF
3 V to 5.5 V	0.1 μF	0.47 μF

Figure 6. Typical Operating Circuit and Capacitor Values

勝特力材料 886-3-5753170
 勝特力电子(上海) 86-21-34970699
 勝特力电子(深圳) 86-755-83298787
[Http://www.100y.com.tw](http://www.100y.com.tw)

PACKAGING INFORMATION

Orderable Device	Status ⁽¹⁾	Package Type	Package Drawing	Pins	Package Qty	Eco Plan ⁽²⁾	Lead/Ball Finish	MSL Peak Temp ⁽³⁾
MAX3221CDB	ACTIVE	SSOP	DB	16	80	Green (RoHS & no Sb/Br)	CU NIPDAU	Level-1-260C-UNLIM
MAX3221CDBE4	ACTIVE	SSOP	DB	16	80	Green (RoHS & no Sb/Br)	CU NIPDAU	Level-1-260C-UNLIM
MAX3221CDBG4	ACTIVE	SSOP	DB	16	80	Green (RoHS & no Sb/Br)	CU NIPDAU	Level-1-260C-UNLIM
MAX3221CDBR	ACTIVE	SSOP	DB	16	2000	Green (RoHS & no Sb/Br)	CU NIPDAU	Level-1-260C-UNLIM
MAX3221CDBRG4	ACTIVE	SSOP	DB	16	2000	Green (RoHS & no Sb/Br)	CU NIPDAU	Level-1-260C-UNLIM
MAX3221CPW	ACTIVE	TSSOP	PW	16	90	Green (RoHS & no Sb/Br)	CU NIPDAU	Level-1-260C-UNLIM
MAX3221CPWE4	ACTIVE	TSSOP	PW	16	90	Green (RoHS & no Sb/Br)	CU NIPDAU	Level-1-260C-UNLIM
MAX3221CPWG4	ACTIVE	TSSOP	PW	16	90	Green (RoHS & no Sb/Br)	CU NIPDAU	Level-1-260C-UNLIM
MAX3221CPWR	ACTIVE	TSSOP	PW	16	2000	Green (RoHS & no Sb/Br)	CU NIPDAU	Level-1-260C-UNLIM
MAX3221CPWRE4	ACTIVE	TSSOP	PW	16	2000	Green (RoHS & no Sb/Br)	CU NIPDAU	Level-1-260C-UNLIM
MAX3221CPWRG4	ACTIVE	TSSOP	PW	16	2000	Green (RoHS & no Sb/Br)	CU NIPDAU	Level-1-260C-UNLIM
MAX3221IDB	ACTIVE	SSOP	DB	16	80	Green (RoHS & no Sb/Br)	CU NIPDAU	Level-1-260C-UNLIM
MAX3221IDBE4	ACTIVE	SSOP	DB	16	80	Green (RoHS & no Sb/Br)	CU NIPDAU	Level-1-260C-UNLIM
MAX3221IDBG4	ACTIVE	SSOP	DB	16	80	Green (RoHS & no Sb/Br)	CU NIPDAU	Level-1-260C-UNLIM
MAX3221IDBR	ACTIVE	SSOP	DB	16	2000	Green (RoHS & no Sb/Br)	CU NIPDAU	Level-1-260C-UNLIM
MAX3221IDBRE4	ACTIVE	SSOP	DB	16	2000	Green (RoHS & no Sb/Br)	CU NIPDAU	Level-1-260C-UNLIM
MAX3221IDBRG4	ACTIVE	SSOP	DB	16	2000	Green (RoHS & no Sb/Br)	CU NIPDAU	Level-1-260C-UNLIM
MAX3221IPW	ACTIVE	TSSOP	PW	16	90	Green (RoHS & no Sb/Br)	CU NIPDAU	Level-1-260C-UNLIM
MAX3221IPWE4	ACTIVE	TSSOP	PW	16	90	Green (RoHS & no Sb/Br)	CU NIPDAU	Level-1-260C-UNLIM
MAX3221IPWG4	ACTIVE	TSSOP	PW	16	90	Green (RoHS & no Sb/Br)	CU NIPDAU	Level-1-260C-UNLIM
MAX3221IPWR	ACTIVE	TSSOP	PW	16	2000	Green (RoHS & no Sb/Br)	CU NIPDAU	Level-1-260C-UNLIM
MAX3221IPWRE4	ACTIVE	TSSOP	PW	16	2000	Green (RoHS & no Sb/Br)	CU NIPDAU	Level-1-260C-UNLIM
MAX3221IPWRG4	ACTIVE	TSSOP	PW	16	2000	Green (RoHS & no Sb/Br)	CU NIPDAU	Level-1-260C-UNLIM

⁽¹⁾ The marketing status values are defined as follows:

ACTIVE: Product device recommended for new designs.

LIFEBUY: TI has announced that the device will be discontinued, and a lifetime-buy period is in effect.

NRND: Not recommended for new designs. Device is in production to support existing customers, but TI does not recommend using this part in a new design.

PREVIEW: Device has been announced but is not in production. Samples may or may not be available.

OBSELETE: TI has discontinued the production of the device.

(2) Eco Plan - The planned eco-friendly classification: Pb-Free (RoHS), Pb-Free (RoHS Exempt), or Green (RoHS & no Sb/Br) - please check <http://www.ti.com/productcontent> for the latest availability information and additional product content details.

TBD: The Pb-Free/Green conversion plan has not been defined.

Pb-Free (RoHS): TI's terms "Lead-Free" or "Pb-Free" mean semiconductor products that are compatible with the current RoHS requirements for all 6 substances, including the requirement that lead not exceed 0.1% by weight in homogeneous materials. Where designed to be soldered at high temperatures, TI Pb-Free products are suitable for use in specified lead-free processes.

Pb-Free (RoHS Exempt): This component has a RoHS exemption for either 1) lead-based flip-chip solder bumps used between the die and package, or 2) lead-based die adhesive used between the die and leadframe. The component is otherwise considered Pb-Free (RoHS compatible) as defined above.

Green (RoHS & no Sb/Br): TI defines "Green" to mean Pb-Free (RoHS compatible), and free of Bromine (Br) and Antimony (Sb) based flame retardants (Br or Sb do not exceed 0.1% by weight in homogeneous material)

(3) MSL, Peak Temp. -- The Moisture Sensitivity Level rating according to the JEDEC industry standard classifications, and peak solder temperature.

Important Information and Disclaimer:The information provided on this page represents TI's knowledge and belief as of the date that it is provided. TI bases its knowledge and belief on information provided by third parties, and makes no representation or warranty as to the accuracy of such information. Efforts are underway to better integrate information from third parties. TI has taken and continues to take reasonable steps to provide representative and accurate information but may not have conducted destructive testing or chemical analysis on incoming materials and chemicals. TI and TI suppliers consider certain information to be proprietary, and thus CAS numbers and other limited information may not be available for release.

In no event shall TI's liability arising out of such information exceed the total purchase price of the TI part(s) at issue in this document sold by TI to Customer on an annual basis.

OTHER QUALIFIED VERSIONS OF MAX3221 :

- Enhanced Product: [MAX3221-EP](#)

NOTE: Qualified Version Definitions:

- Enhanced Product - Supports Defense, Aerospace and Medical Applications

勝特力材料 886-3-5753170
勝特力电子(上海) 86-21-34970699
勝特力电子(深圳) 86-755-83298787
[Http://www.100y.com.tw](http://www.100y.com.tw)

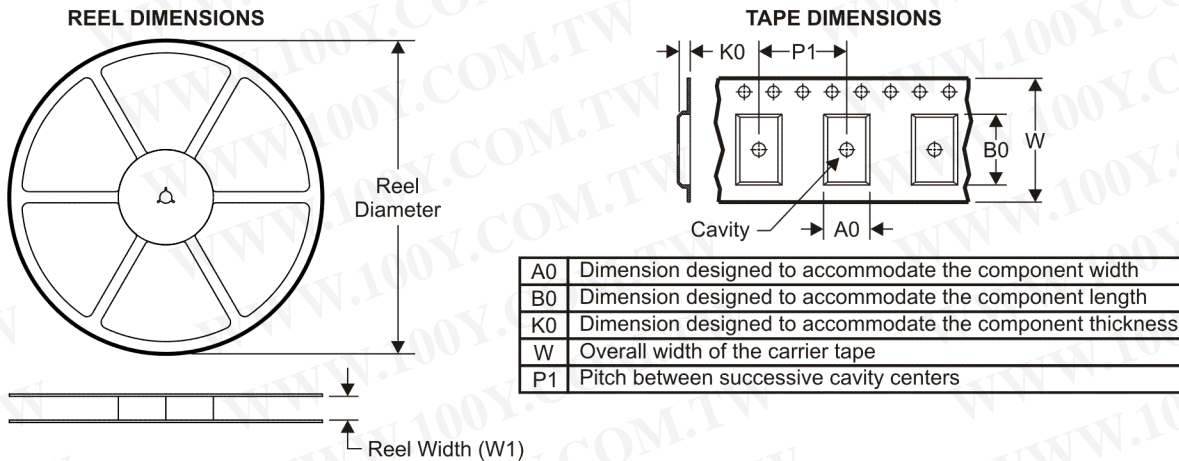
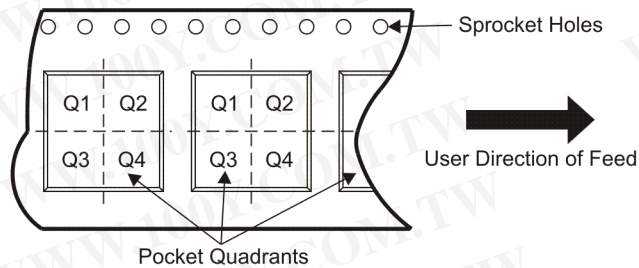
TAPE AND REEL INFORMATION

QUADRANT ASSIGNMENTS FOR PIN 1 ORIENTATION IN TAPE

*All dimensions are nominal

Device	Package Type	Package Drawing	Pins	SPQ	Reel Diameter (mm)	Reel Width W1 (mm)	A0 (mm)	B0 (mm)	K0 (mm)	P1 (mm)	W (mm)	Pin1 Quadrant
MAX3221CDBR	SSOP	DB	16	2000	330.0	16.4	8.2	6.6	2.5	12.0	16.0	Q1
MAX3221CPWR	TSSOP	PW	16	2000	330.0	12.4	6.9	5.6	1.6	8.0	12.0	Q1
MAX3221IDBR	SSOP	DB	16	2000	330.0	16.4	8.2	6.6	2.5	12.0	16.0	Q1
MAX3221IPWR	TSSOP	PW	16	2000	330.0	12.4	6.9	5.6	1.6	8.0	12.0	Q1

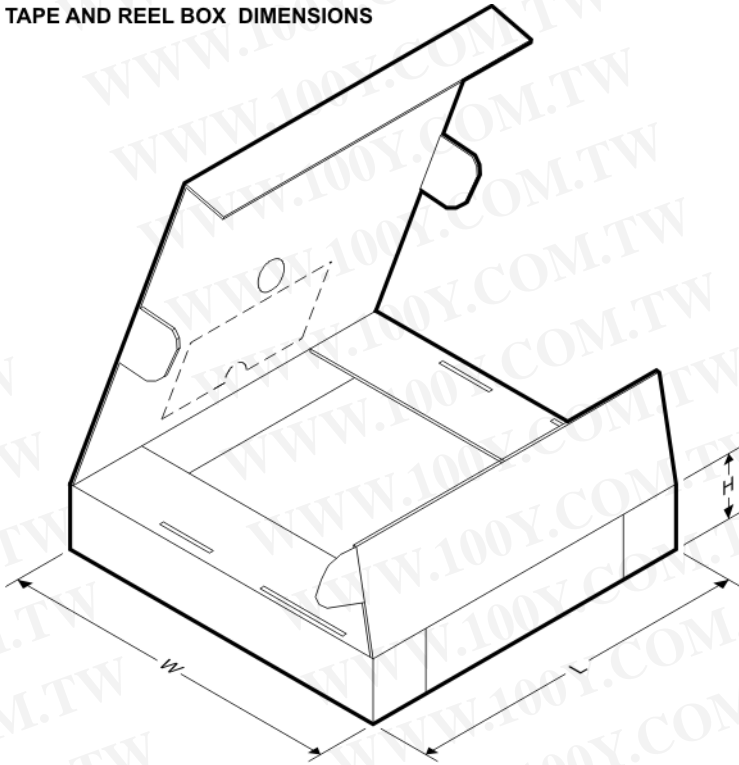
勝特力材料 886-3-5753170
 勝特力电子(上海) 86-21-34970699
 勝特力电子(深圳) 86-755-83298787
[Http://www.100y.com.tw](http://www.100y.com.tw)

TAPE AND REEL BOX DIMENSIONS

*All dimensions are nominal

Device	Package Type	Package Drawing	Pins	SPQ	Length (mm)	Width (mm)	Height (mm)
MAX3221CDBR	SSOP	DB	16	2000	346.0	346.0	33.0
MAX3221CPWR	TSSOP	PW	16	2000	346.0	346.0	29.0
MAX3221IDBR	SSOP	DB	16	2000	346.0	346.0	33.0
MAX3221IPWR	TSSOP	PW	16	2000	346.0	346.0	29.0

勝特力材料 886-8-5753170
勝特力电子(上海) 86-21-34970699
勝特力电子(深圳) 86-755-83298787
[Http://www.100y.com.tw](http://www.100y.com.tw)

MECHANICAL DATA

PW (R-PDSO-G16)

PLASTIC SMALL OUTLINE

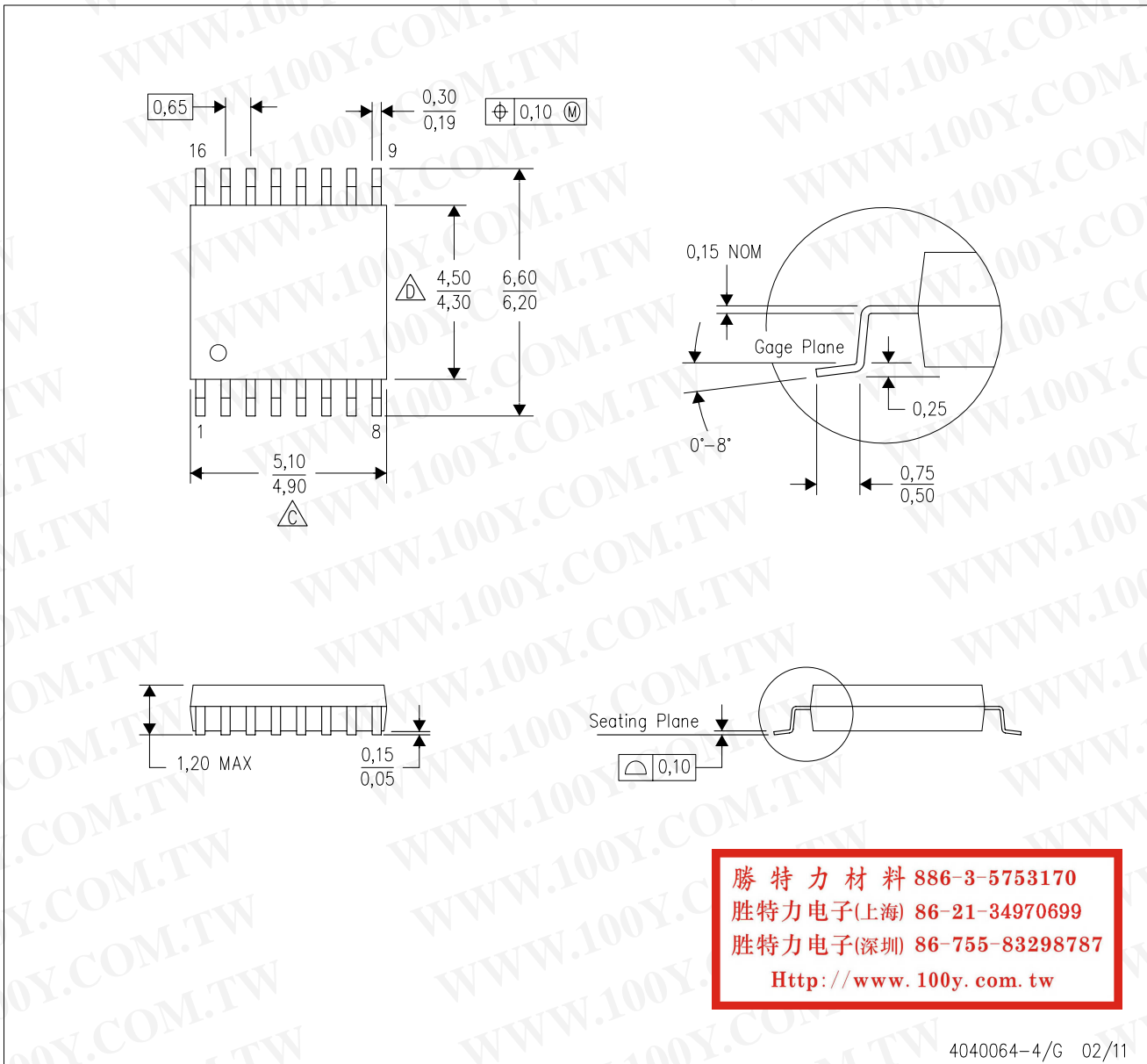

- NOTES:
- A. All linear dimensions are in millimeters. Dimensioning and tolerancing per ASME Y14.5M-1994.
 - B. This drawing is subject to change without notice.
 - C. Body length does not include mold flash, protrusions, or gate burrs. Mold flash, protrusions, or gate burrs shall not exceed 0,15 each side.
 - D. Body width does not include interlead flash. Interlead flash shall not exceed 0,25 each side.
 - E. Falls within JEDEC MO-153

PW (R-PDSO-G16)

PLASTIC SMALL OUTLINE

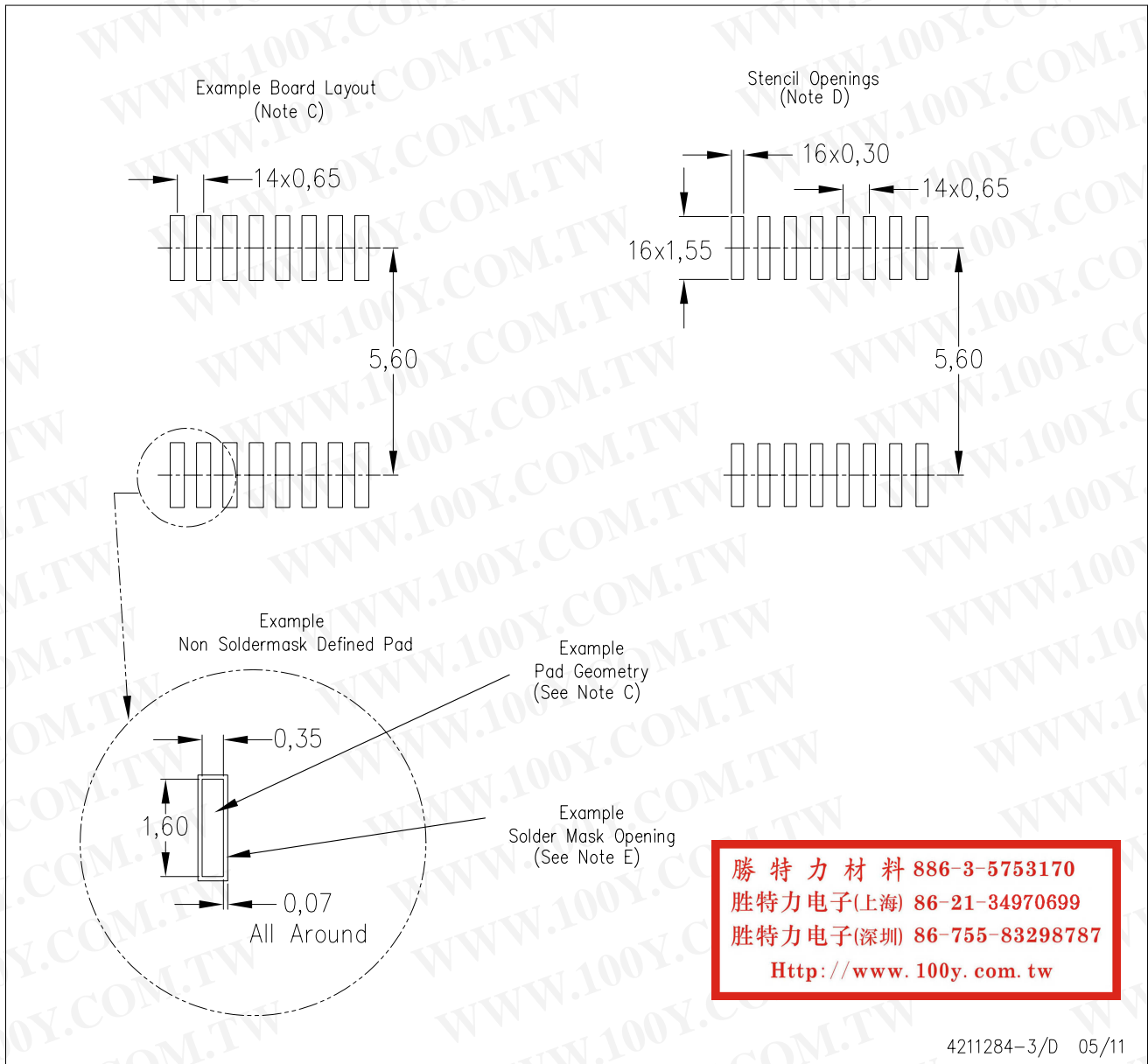

- NOTES:
- All linear dimensions are in millimeters.
 - This drawing is subject to change without notice.
 - Publication IPC-7351 is recommended for alternate designs.
 - Laser cutting apertures with trapezoidal walls and also rounding corners will offer better paste release. Customers should contact their board assembly site for stencil design recommendations. Refer to IPC-7525 for other stencil recommendations.
 - Customers should contact their board fabrication site for solder mask tolerances between and around signal pads.

DB (R-PDSO-G**)

PLASTIC SMALL-OUTLINE

28 PINS SHOWN

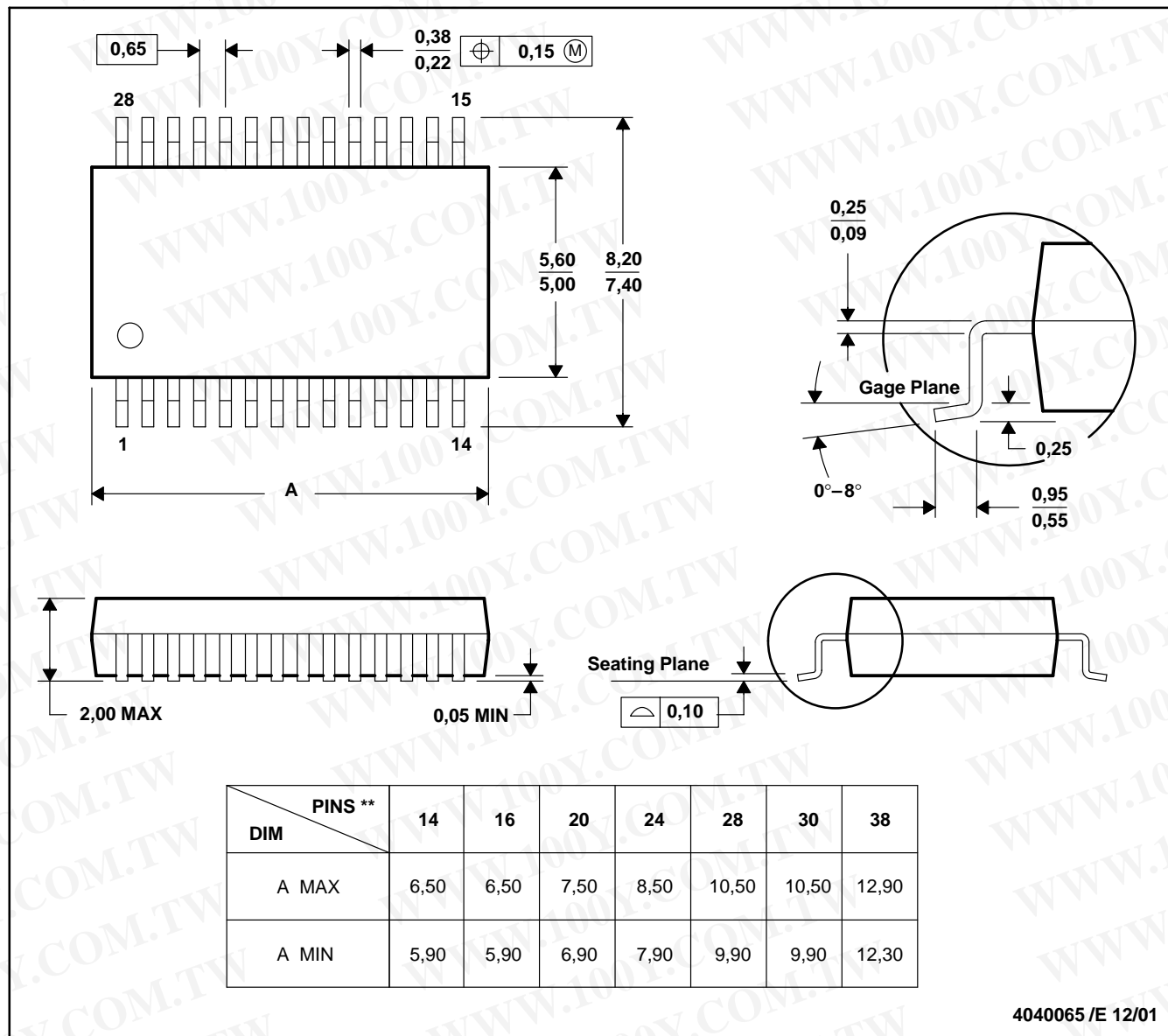

- NOTES: A. All linear dimensions are in millimeters.
 B. This drawing is subject to change without notice.
 C. Body dimensions do not include mold flash or protrusion not to exceed 0,15.
 D. Falls within JEDEC MO-150

勝特力材料 886-3-5753170
 勝特力电子(上海) 86-21-34970699
 勝特力电子(深圳) 86-755-83298787
[Http://www.100y.com.tw](http://www.100y.com.tw)

IMPORTANT NOTICE

Texas Instruments Incorporated and its subsidiaries (TI) reserve the right to make corrections, modifications, enhancements, improvements, and other changes to its products and services at any time and to discontinue any product or service without notice. Customers should obtain the latest relevant information before placing orders and should verify that such information is current and complete. All products are sold subject to TI's terms and conditions of sale supplied at the time of order acknowledgment.

TI warrants performance of its hardware products to the specifications applicable at the time of sale in accordance with TI's standard warranty. Testing and other quality control techniques are used to the extent TI deems necessary to support this warranty. Except where mandated by government requirements, testing of all parameters of each product is not necessarily performed.

TI assumes no liability for applications assistance or customer product design. Customers are responsible for their products and applications using TI components. To minimize the risks associated with customer products and applications, customers should provide adequate design and operating safeguards.

TI does not warrant or represent that any license, either express or implied, is granted under any TI patent right, copyright, mask work right, or other TI intellectual property right relating to any combination, machine, or process in which TI products or services are used. Information published by TI regarding third-party products or services does not constitute a license from TI to use such products or services or a warranty or endorsement thereof. Use of such information may require a license from a third party under the patents or other intellectual property of the third party, or a license from TI under the patents or other intellectual property of TI.

Reproduction of TI information in TI data books or data sheets is permissible only if reproduction is without alteration and is accompanied by all associated warranties, conditions, limitations, and notices. Reproduction of this information with alteration is an unfair and deceptive business practice. TI is not responsible or liable for such altered documentation. Information of third parties may be subject to additional restrictions.

Resale of TI products or services with statements different from or beyond the parameters stated by TI for that product or service voids all express and any implied warranties for the associated TI product or service and is an unfair and deceptive business practice. TI is not responsible or liable for any such statements.

TI products are not authorized for use in safety-critical applications (such as life support) where a failure of the TI product would reasonably be expected to cause severe personal injury or death, unless officers of the parties have executed an agreement specifically governing such use. Buyers represent that they have all necessary expertise in the safety and regulatory ramifications of their applications, and acknowledge and agree that they are solely responsible for all legal, regulatory and safety-related requirements concerning their products and any use of TI products in such safety-critical applications, notwithstanding any applications-related information or support that may be provided by TI. Further, Buyers must fully indemnify TI and its representatives against any damages arising out of the use of TI products in such safety-critical applications.

TI products are neither designed nor intended for use in military/aerospace applications or environments unless the TI products are specifically designated by TI as military-grade or "enhanced plastic." Only products designated by TI as military-grade meet military specifications. Buyers acknowledge and agree that any such use of TI products which TI has not designated as military-grade is solely at the Buyer's risk, and that they are solely responsible for compliance with all legal and regulatory requirements in connection with such use.

TI products are neither designed nor intended for use in automotive applications or environments unless the specific TI products are designated by TI as compliant with ISO/TS 16949 requirements. Buyers acknowledge and agree that, if they use any non-designated products in automotive applications, TI will not be responsible for any failure to meet such requirements.

Following are URLs where you can obtain information on other Texas Instruments products and application solutions:

Products

Audio	www.ti.com/audio
Amplifiers	amplifier.ti.com
Data Converters	dataconverter.ti.com
DLP® Products	www.dlp.com
DSP	dsp.ti.com
Clocks and Timers	www.ti.com/clocks
Interface	interface.ti.com
Logic	logic.ti.com
Power Mgmt	power.ti.com
Microcontrollers	microcontroller.ti.com
RFID	www.ti-rfid.com
RF/IF and ZigBee® Solutions	www.ti.com/lprf

Applications

Communications and Telecom	www.ti.com/communications
Computers and Peripherals	www.ti.com/computers
Consumer Electronics	www.ti.com/consumer-apps
Energy and Lighting	www.ti.com/energy
Industrial	www.ti.com/industrial
Medical	www.ti.com/medical
Security	www.ti.com/security
Space, Avionics and Defense	www.ti.com/space-avionics-defense
Transportation and Automotive	www.ti.com/automotive
Video and Imaging	www.ti.com/video
Wireless	www.ti.com/wireless-apps

TI E2E Community Home Page

e2e.ti.com

Mailing Address: Texas Instruments, Post Office Box 655303, Dallas, Texas 75265
Copyright © 2011, Texas Instruments Incorporated

勝特力材料 886-3-5753170
勝特力电子(上海) 86-21-34970699
勝特力电子(深圳) 86-755-83298787
[Http://www.100y.com.tw](http://www.100y.com.tw)