

## High voltage high and low-side driver

Datasheet - production data

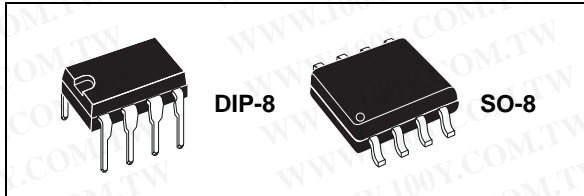

### Features

- High voltage rail up to 600 V
- $dV/dt$  immunity  $\pm 50$  V/nsec in full temperature range
- Driver current capability
  - 400 mA source
  - 650 mA sink
- Switching times 50/30 nsec rise/fall with 1 nF load
- CMOS/TTL Schmitt trigger inputs with hysteresis and pull-down
- Internal bootstrap diode
- Outputs in phase with inputs
- Interlocking function

### Applications

- Home appliances
- Motor drivers
  - DC, AC, PMDC and PMAC motors
- Lighting applications
- Industrial applications and drives
- Induction heating
- HVAC
- Factory automation
- Power supply systems

### Description

The L6387E is a simple and compact high voltage gate driver, manufactured with the BCD™ “offline” technology, and able to drive a half-bridge of power MOS or IGBT devices. The high-side (floating) section is enabled to work with voltage rail up to 600 V. Both device outputs can independently sink and source 650 mA and 400 mA respectively and cannot be simultaneously driven high thanks to an integrated interlocking function.

The L6387E device provides two input pins and two output pins and guarantees the outputs toggle in phase with inputs. The logic inputs are CMOS/TTL compatible to ease the interfacing with controlling devices.

The L6387E features the UVLO protection on the  $V_{CC}$  supply voltage and integrates the bootstrap diode, allowing a more compact and reliable solution.

The device is available in a DIP-8 tube and SO-8 tube and tape and reel packaging options.

Table 1. Device summary

Part number	Package	Packaging
L6387E	DIP-8	Tube
L6387ED	SO-8	Tube
L6387ED013TR	SO-8	Tape and reel

# Contents

<b>1</b>	<b>Block diagram</b> .....	<b>3</b>
<b>2</b>	<b>Electrical data</b> .....	<b>4</b>
2.1	Absolute maximum ratings .....	4
2.2	Thermal data .....	4
2.3	Recommended operating conditions .....	4
<b>3</b>	<b>Pin connection</b> .....	<b>5</b>
<b>4</b>	<b>Electrical characteristics</b> .....	<b>6</b>
4.1	AC operation .....	6
4.2	DC operation .....	6
<b>5</b>	<b>Input logic</b> .....	<b>8</b>
<b>6</b>	<b>Bootstrap driver</b> .....	<b>9</b>
	C <sub>BOOT</sub> selection and charging .....	9
<b>7</b>	<b>Typical characteristic</b> .....	<b>11</b>
<b>8</b>	<b>Package information</b> .....	<b>12</b>
<b>9</b>	<b>Revision history</b> .....	<b>14</b>

勝特力材料 886-3-5753170  
勝特力电子(上海) 86-21-34970699  
勝特力电子(深圳) 86-755-83298787  
[Http://www.100y.com.tw](http://www.100y.com.tw)

# 1 Block diagram

Figure 1. Block diagram

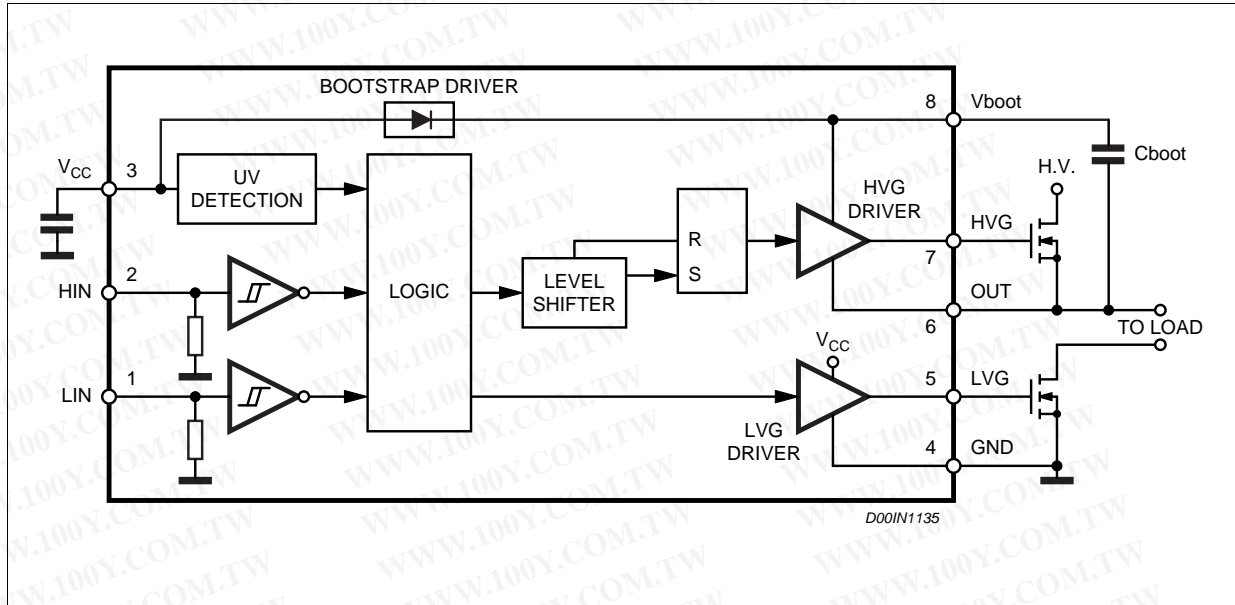

勝特力材料 886-3-5753170  
勝特力电子(上海) 86-21-34970699  
勝特力电子(深圳) 86-755-83298787  
[Http://www.100y.com.tw](http://www.100y.com.tw)

## 2 Electrical data

### 2.1 Absolute maximum ratings

Table 2. Absolute maximum ratings

Symbol	Parameter	Value	Unit
$V_{out}$	Output voltage	-3 to $V_{boot} - 18$	V
$V_{cc}$	Supply voltage	- 0.3 to +18	V
$V_{boot}$	Floating supply voltage	-1 to 618	V
$V_{hvg}$	High-side gate output voltage	-1 to $V_{boot}$	V
$V_{lvg}$	Low-side gate output voltage	-0.3 to $V_{cc} + 0.3$	V
$V_i$	Logic input voltage	-0.3 to $V_{cc} + 0.3$	V
$dV_{out}/dt$	Allowed output slew rate	50	V/ns
$P_{tot}$	Total power dissipation ( $T_J = 85\text{ °C}$ )	750	mW
$T_j$	Junction temperature	150	°C
$T_s$	Storage temperature	-50 to 150	°C

### 2.2 Thermal data

Table 3. Thermal data

Symbol	Parameter	SO-8	DIP-8	Unit
$R_{th(JA)}$	Thermal resistance junction to ambient	150	100	°C/W

### 2.3 Recommended operating conditions

Table 4. Recommended operating conditions

Symbol	Pin	Parameter	Test condition	Min.	Typ.	Max.	Unit
$V_{out}$	6	Output voltage		(1)		580	V
$V_{BS}^{(2)}$	8	Floating supply voltage		(1)		17	V
$f_{sw}$		Switching frequency	HVG, LVG load $C_L = 1\text{ nF}$			400	kHz
$V_{cc}$	3	Supply voltage				17	V
$T_J$		Junction temperature		-45		125	°C

1. If the condition  $V_{boot} - V_{out} < 18\text{ V}$  is guaranteed,  $V_{out}$  can range from -3 to 580 V.

2.  $V_{BS} = V_{boot} - V_{out}$ .

### 3 Pin connection

Figure 2. Pin connection (top view)

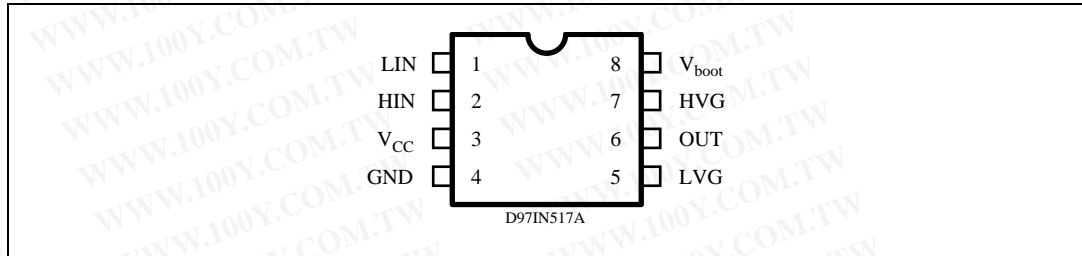

Table 5. Pin description

No.	Pin	Type	Function
1	LIN	I	Low-side driver logic input
2	HIN	I	High-side driver logic input
3	V <sub>CC</sub>	P	Low voltage power supply
4	GND	P	Ground
5	LVG <sup>(1)</sup>	O	Low-side driver output
6	OUT	P	High-side driver floating reference
7	HVG <sup>(1)</sup>	O	High-side driver output
8	V <sub>boot</sub>	P	Bootstrap supply voltage

1. The circuit guarantees 0.3 V maximum on the pin (at I<sub>sink</sub> = 10 mA). This allows to omit the “bleeder” resistor connected between the gate and the source of the external MOSFET normally used to hold the pin low.

勝特力材料 886-3-5753170  
 勝特力电子(上海) 86-21-34970699  
 勝特力电子(深圳) 86-755-83298787  
[Http://www.100y.com.tw](http://www.100y.com.tw)

## 4 Electrical characteristics

### 4.1 AC operation

Table 6. AC operation electrical characteristics ( $V_{CC} = 15\text{ V}$ ;  $T_J = 25\text{ °C}$ )

Symbol	Pin	Parameter	Test condition	Min.	Typ.	Max.	Unit
$t_{on}$	1 vs. 5 2 vs. 7	High/low-side driver turn-on propagation delay	$V_{out} = 0\text{ V}$		110		ns
$t_{off}$	1 vs. 5 2 vs. 7	High/low-side driver turn-off propagation delay	$V_{out} = 0\text{ V}$		105		ns
$t_r$	5, 7	Rise time	$C_L = 1000\text{ pF}$		50		ns
$t_f$	5, 7	Fall time	$C_L = 1000\text{ pF}$		30		ns

### 4.2 DC operation

Table 7. DC operation electrical characteristics ( $V_{CC} = 15\text{ V}$ ;  $T_J = 25\text{ °C}$ )

Symbol	Pin	Parameter	Test condition	Min.	Typ.	Max.	Unit
<b>Low supply voltage section</b>							
$V_{CC}$	3	Supply voltage				17	V
$V_{ccth1}$		$V_{CC}$ UV turn-on threshold		5.5	6	6.5	V
$V_{ccth2}$		$V_{CC}$ UV turn-off threshold		5	5.5	6	V
$V_{cchys}$		$V_{CC}$ UV hysteresis			0.5		V
$I_{qccu}$		Undervoltage quiescent supply current	$V_{CC} \leq 5\text{ V}$		150	220	$\mu\text{A}$
$I_{qcc}$		Quiescent current	$V_{CC} = 15\text{ V}$		250	320	$\mu\text{A}$
$R_{dson}$		Bootstrap driver on-resistance <sup>(1)</sup>	$V_{CC} \geq 12.5\text{ V}$		125		$\Omega$
<b>Bootstrapped supply voltage section</b>							
$V_{BS}$	8	Bootstrap supply voltage				17	V
$I_{QBS}$		$V_{BS}$ quiescent current	HVG ON			100	$\mu\text{A}$
$I_{LK}$		High voltage leakage current	$V_{hvg} = V_{out} =$ $V_{boot} = 600\text{ V}$			10	$\mu\text{A}$
<b>High/low-side driver</b>							
$I_{so}$	5, 7	Source short-circuit current	$V_{IN} = V_{ih}$ ( $t_p < 10\text{ }\mu\text{s}$ )	300	400		mA
$I_{si}$		Sink short-circuit current	$V_{IN} = V_{il}$ ( $t_p < 10\text{ }\mu\text{s}$ )	450	650		mA

Table 7. DC operation electrical characteristics (continued) ( $V_{CC} = 15\text{ V}$ ;  $T_J = 25\text{ }^\circ\text{C}$ )

Symbol	Pin	Parameter	Test condition	Min.	Typ.	Max.	Unit
<b>Logic inputs</b>							
$V_{il}$	1, 2	Low level logic threshold voltage				1.5	V
$V_{ih}$		High level logic threshold voltage		3.6			V
$I_{ih}$		High level logic input current	$V_{IN} = 15\text{ V}$		50	70	$\mu\text{A}$
$I_{il}$		Low level logic input current	$V_{IN} = 0\text{ V}$			1	$\mu\text{A}$

1.  $R_{DS(on)}$  is tested in the following way:

$$R_{DS(on)} = \frac{(V_{CC} - V_{CBOOT1}) - (V_{CC} - V_{CBOOT2})}{I_1(V_{CC}, V_{CBOOT1}) - I_2(V_{CC}, V_{CBOOT2})}$$

where  $I_1$  is the pin 8 current when  $V_{CBOOT} = V_{CBOOT1}$ ,  $I_2$  when  $V_{CBOOT} = V_{CBOOT2}$ .

## 5 Input logic

L6387E input logic is  $V_{CC}$  (17 V) compatible. An interlocking feature is offered (see [Table 8](#)) to avoid undesired simultaneous turn-ON of both power switches driven.

**Table 8. Input logic**

Input		Output	
HIN	LIN	HVG	LVG
0	0	0	0
0	1	0	1
1	0	1	0
1	1	0	0

勝特力材料 886-3-5753170  
 勝特力电子(上海) 86-21-34970699  
 勝特力电子(深圳) 86-755-83298787  
[Http://www.100y.com.tw](http://www.100y.com.tw)

## 6 Bootstrap driver

A bootstrap circuitry is needed to supply the high voltage section. This function is normally accomplished by a high voltage fast recovery diode (*Figure 3 a*). In the L6387E device a patented integrated structure replaces the external diode. It is realized by a high voltage DMOS, driven synchronously with the low-side driver (LVG), with a diode in series, as shown in *Figure 3 b*. An internal charge pump (*Figure 3 b*) provides the DMOS driving voltage. The diode connected in series to the DMOS has been added to avoid undesirable turn-on.

### C<sub>BOOT</sub> selection and charging

To choose the proper C<sub>BOOT</sub> value, the external MOS can be seen as an equivalent capacitor. This capacitor C<sub>EXT</sub> is related to the MOS total gate charge:

#### Equation 1

$$C_{EXT} = \frac{Q_{gate}}{V_{gate}}$$

The ratio between the C<sub>EXT</sub> and C<sub>BOOT</sub> capacitors is proportional to the cyclical voltage loss. It has to be:

$$C_{BOOT} \gg C_{EXT}$$

E.g.: if Q<sub>gate</sub> is 30 nC and V<sub>gate</sub> is 10 V, C<sub>EXT</sub> is 3 nF. With C<sub>BOOT</sub> = 100 nF the drop would be 300 mV.

If HVG has to be supplied for a long time, the C<sub>BOOT</sub> selection has to take into account also the leakage losses.

E.g.: HVG steady state consumption is lower than 100 μA, so if HVG T<sub>ON</sub> is 5 ms, C<sub>BOOT</sub> has to supply a maximum of 0.5 μC to C<sub>EXT</sub>. This charge on a 1 μF capacitor means a voltage drop of 0.5 V.

The internal bootstrap driver gives great advantages: the external fast recovery diode can be avoided (it usually has a great leakage current).

This structure can work only if V<sub>OUT</sub> is close to GND (or lower) and in the meanwhile the LVG is on. The charging time (T<sub>charge</sub>) of the C<sub>BOOT</sub> is the time in which both conditions are fulfilled and it has to be long enough to charge the capacitor.

The bootstrap driver introduces a voltage drop due to the DMOS R<sub>DSON</sub> (typical value: 125 Ω). At low frequency this drop can be neglected. Anyway increasing the frequency it must be taken into account.

The following equation is useful to compute the drop on the bootstrap DMOS:

#### Equation 2

$$V_{drop} = I_{charge} R_{dson} \rightarrow V_{drop} = \frac{Q_{gate}}{T_{charge}} R_{dson}$$

where Q<sub>gate</sub> is the gate charge of the external power MOS, R<sub>dson</sub> is the on-resistance of the bootstrap DMOS, and T<sub>charge</sub> is the charging time of the bootstrap capacitor.

For example: using a power MOS with a total gate charge of 30 nC the drop on the bootstrap DMOS is about 1 V, if the  $T_{charge}$  is 5 $\mu$ s. In fact:

**Equation 3**

$$V_{drop} = \frac{30nC}{5\mu s} \cdot 125\Omega \sim 0.8V$$

$V_{drop}$  has to be taken into account when the voltage drop on  $C_{BOOT}$  is calculated: if this drop is too high, or the circuit topology doesn't allow a sufficient charging time, an external diode can be used.

**Figure 3. Bootstrap driver**

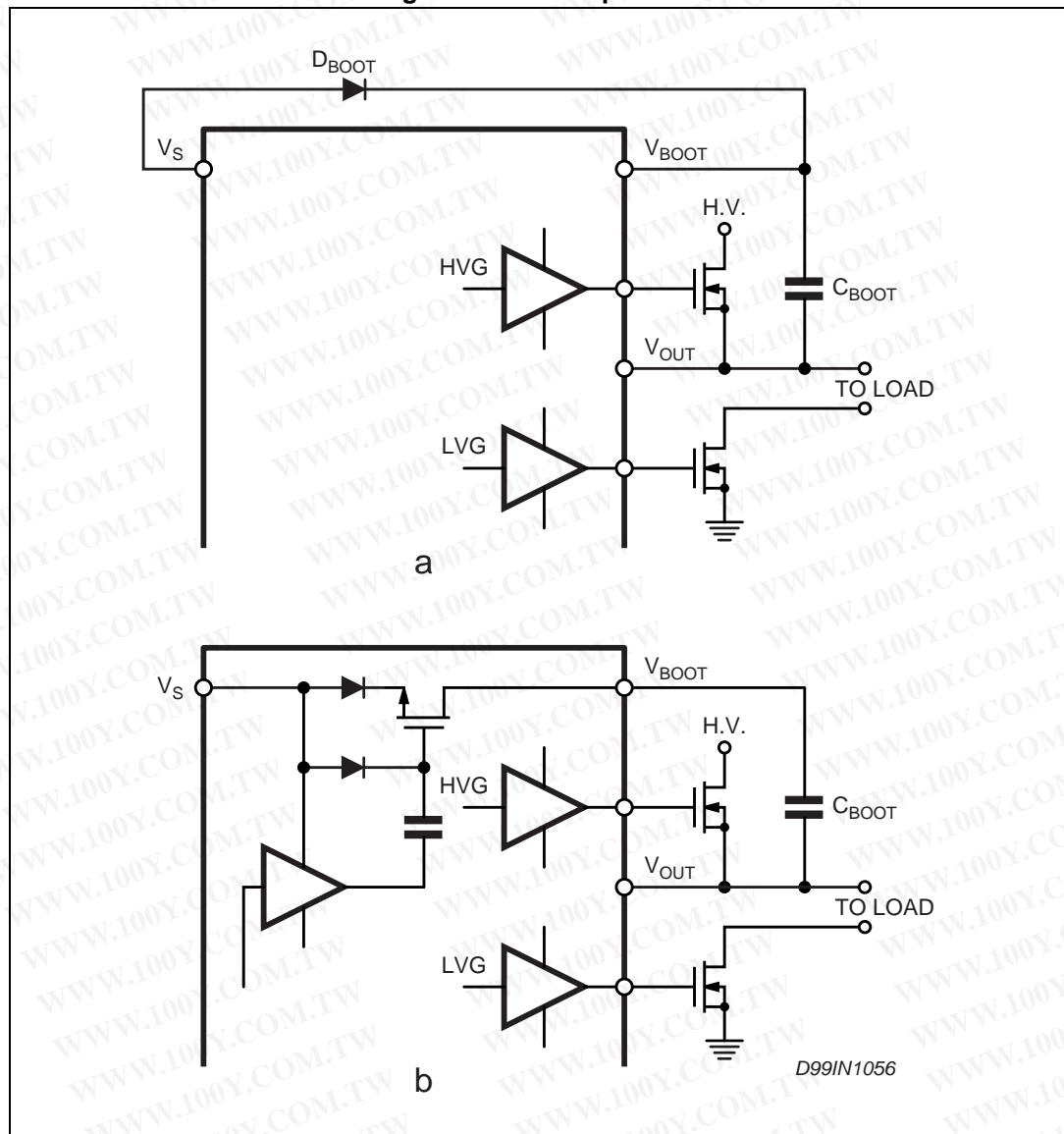

# 7 Typical characteristic

**Figure 4. Typical rise and fall times vs. load capacitance**

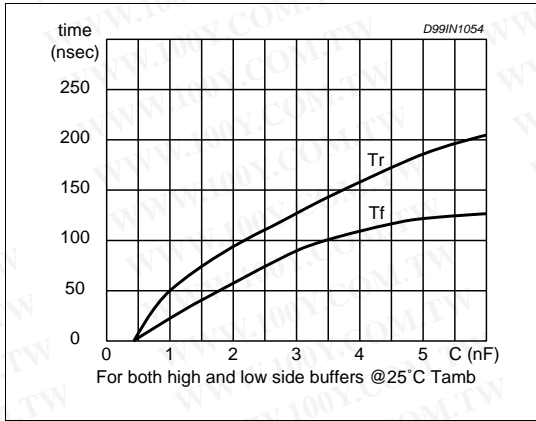

**Figure 5. Quiescent current vs. supply voltage**

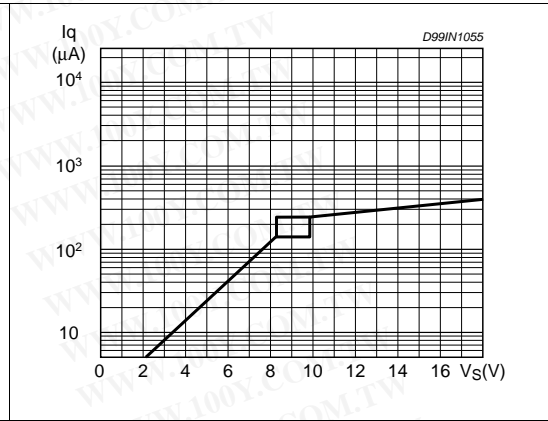

**Figure 6. Turn-on time vs. temperature**

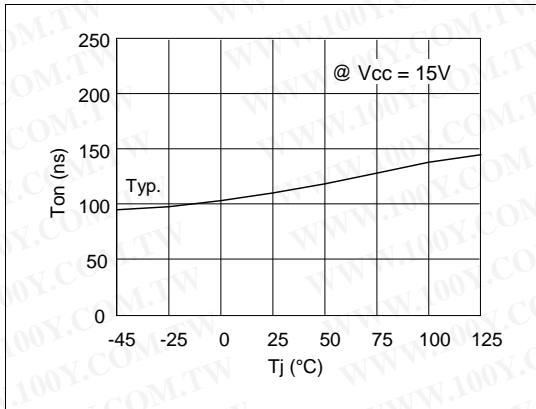

**Figure 7. Turn-off time vs. temperature**

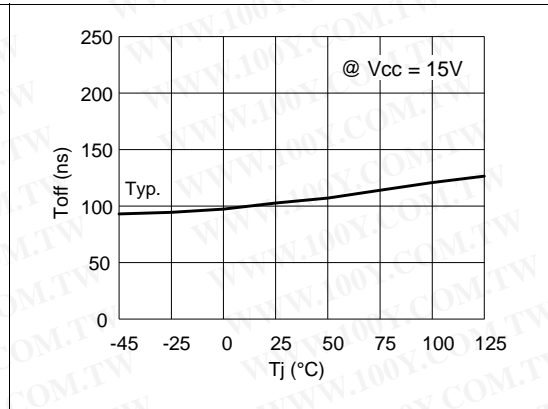

**Figure 8. Output source current vs. temperature**

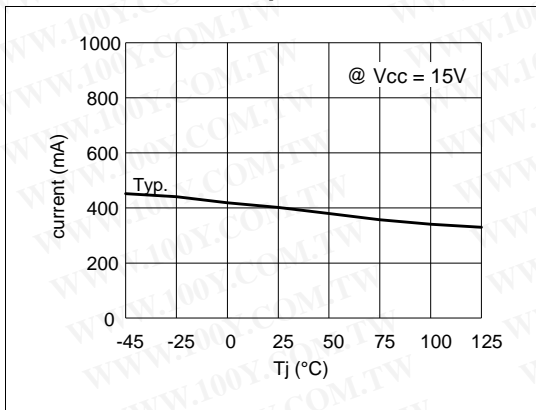

**Figure 9. Output sink current vs. temperature**

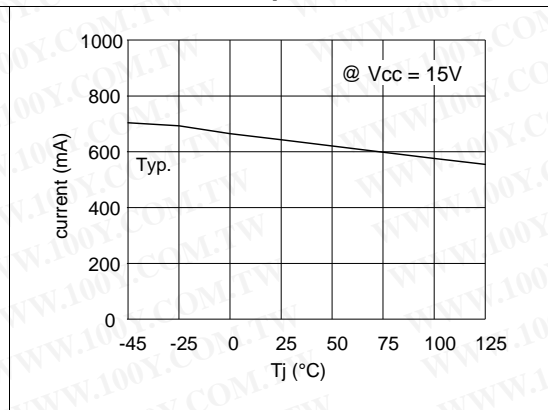

## 8 Package information

In order to meet environmental requirements, ST offers these devices in different grades of ECOPACK® packages, depending on their level of environmental compliance. ECOPACK specifications, grade definitions and product status are available at: [www.st.com](http://www.st.com). ECOPACK is an ST trademark.

Figure 10. DIP-8 package outline

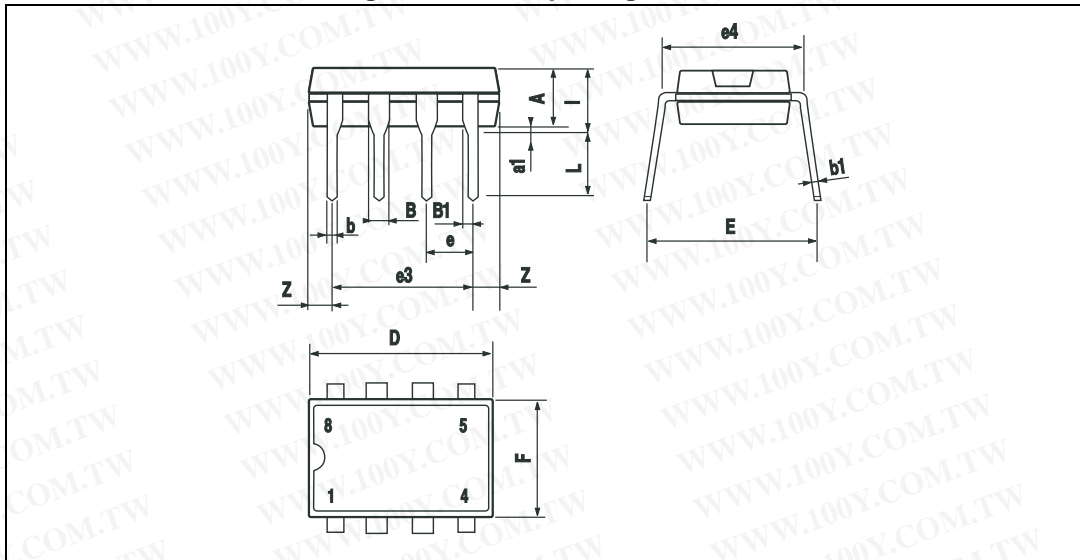

Table 9. DIP-8 package mechanical data

Symbol	Dimensions (mm)			Dimensions (inch)		
	Min.	Typ.	Max.	Min.	Typ.	Max.
A		3.32			0.131	
a1	0.51			0.020		
B	1.15		1.65	0.045		0.065
b	0.356		0.55	0.014		0.022
b1	0.204		0.304	0.008		0.012
D			10.92			0.430
E	7.95		9.75	0.313		0.384
e		2.54			0.100	
e3		7.62			0.300	
e4		7.62			0.300	
F			6.6			0.260
I			5.08			0.200
L	3.18		3.81	0.125		0.150
Z			1.52			0.060

Figure 11. SO-8 package outline

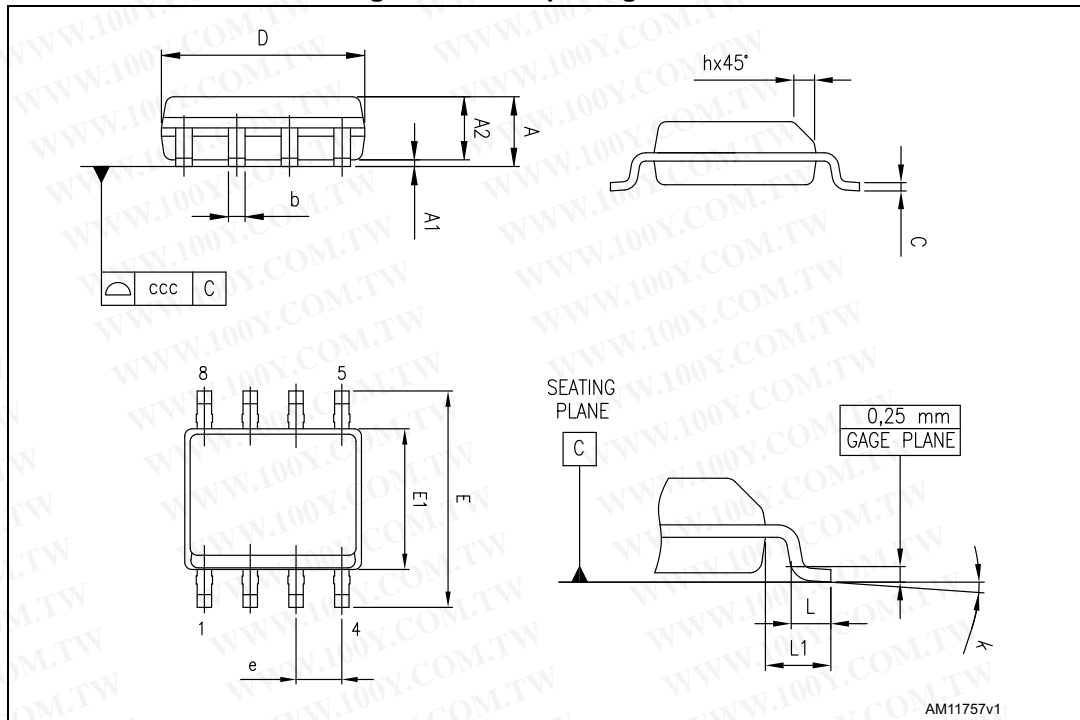

Table 10. SO-8 package mechanical data

Symbol	Dimensions (mm)			Dimensions (inch)		
	Min.	Typ.	Max.	Min.	Typ.	Max.
A			1.750			0.0689
A1	0.100		0.250	0.0039		0.0098
A2	1.250			0.0492		
b	0.280		0.480	0.0110		0.0189
c	0.170		0.230	0.0067		0.0091
D <sup>(1)</sup>	4.800	4.900	5.000	0.1890	0.1929	0.1969
E	5.800	6.000	6.200	0.2283	0.2362	0.2441
E1 <sup>(2)</sup>	3.800	3.900	4.000	0.1496	0.1535	0.1575
e		1.270			0.0500	
h	0.250		0.500	0.0098		0.0197
L	0.400		1.270	0.0157		0.0500
L1		1.040			0.0409	
k	0°		8°	0°		8°
ccc			0.10			0.0039

1. Dimension "D" does not include mold flash, protrusions or gate burrs. Mold flash, protrusions or gate burrs shall not exceed 0.15 mm in total (both sides).
2. Dimension "E1" does not include interlead flash or protrusions. Interlead flash or protrusions shall not exceed 0.25 mm per side.

## 9 Revision history

**Table 11. Document revision history**

Date	Revision	Changes
11-Oct-2007	1	First release
19-Sep-2008	2	Minor text changes on <a href="#">Table 7</a>
19-Jun-2014	3	<p>Added <a href="#">Section : Applications on page 1</a>.</p> <p>Updated <a href="#">Section : Description on page 1</a> (replaced by new description).</p> <p>Updated <a href="#">Table 1: Device summary on page 1</a> (moved from page 15, updated title).</p> <p>Updated <a href="#">Figure 1: Block diagram on page 3</a> (moved from page 1 to page 3, added title to <a href="#">Section 1: Block diagram on page 3</a>).</p> <p>Updated <a href="#">Section 2.1: Absolute maximum ratings on page 4</a> (removed note below <a href="#">Table 2: Absolute maximum ratings</a>).</p> <p>Updated <a href="#">Table 5: Pin description on page 5</a> (updated "Pin" and "Types").</p> <p>Added cross-references in <a href="#">Section 5: Input logic on page 8</a>.</p> <p>Updated <a href="#">Section 6: Bootstrap driver on page 9</a> (updated values of "E.g.: HVG").</p> <p>Numbered <a href="#">Equation 1 on page 9</a>, <a href="#">Equation 2 on page 9</a> and <a href="#">Equation 3 on page 10</a>.</p> <p>Updated <a href="#">Section 8: Package information on page 12</a> [updated/added titles, reversed order of <a href="#">Figure 10</a> and <a href="#">Table 9</a>, <a href="#">Figure 11</a> and <a href="#">Table 10</a> (numbered tables), removed 3D package figures, minor modifications].</p> <p>Minor modifications throughout document.</p>

勝特力材料 886-3-5753170  
 勝特力电子(上海) 86-21-34970699  
 勝特力电子(深圳) 86-755-83298787  
[Http://www.100y.com.tw](http://www.100y.com.tw)

**Please Read Carefully:**

Information in this document is provided solely in connection with ST products. STMicroelectronics NV and its subsidiaries ("ST") reserve the right to make changes, corrections, modifications or improvements, to this document, and the products and services described herein at any time, without notice.

All ST products are sold pursuant to ST's terms and conditions of sale.

Purchasers are solely responsible for the choice, selection and use of the ST products and services described herein, and ST assumes no liability whatsoever relating to the choice, selection or use of the ST products and services described herein.

No license, express or implied, by estoppel or otherwise, to any intellectual property rights is granted under this document. If any part of this document refers to any third party products or services it shall not be deemed a license grant by ST for the use of such third party products or services, or any intellectual property contained therein or considered as a warranty covering the use in any manner whatsoever of such third party products or services or any intellectual property contained therein.

**UNLESS OTHERWISE SET FORTH IN ST'S TERMS AND CONDITIONS OF SALE ST DISCLAIMS ANY EXPRESS OR IMPLIED WARRANTY WITH RESPECT TO THE USE AND/OR SALE OF ST PRODUCTS INCLUDING WITHOUT LIMITATION IMPLIED WARRANTIES OF MERCHANTABILITY, FITNESS FOR A PARTICULAR PURPOSE (AND THEIR EQUIVALENTS UNDER THE LAWS OF ANY JURISDICTION), OR INFRINGEMENT OF ANY PATENT, COPYRIGHT OR OTHER INTELLECTUAL PROPERTY RIGHT.**

**ST PRODUCTS ARE NOT DESIGNED OR AUTHORIZED FOR USE IN: (A) SAFETY CRITICAL APPLICATIONS SUCH AS LIFE SUPPORTING, ACTIVE IMPLANTED DEVICES OR SYSTEMS WITH PRODUCT FUNCTIONAL SAFETY REQUIREMENTS; (B) AERONAUTIC APPLICATIONS; (C) AUTOMOTIVE APPLICATIONS OR ENVIRONMENTS, AND/OR (D) AEROSPACE APPLICATIONS OR ENVIRONMENTS. WHERE ST PRODUCTS ARE NOT DESIGNED FOR SUCH USE, THE PURCHASER SHALL USE PRODUCTS AT PURCHASER'S SOLE RISK, EVEN IF ST HAS BEEN INFORMED IN WRITING OF SUCH USAGE, UNLESS A PRODUCT IS EXPRESSLY DESIGNATED BY ST AS BEING INTENDED FOR "AUTOMOTIVE, AUTOMOTIVE SAFETY OR MEDICAL" INDUSTRY DOMAINS ACCORDING TO ST PRODUCT DESIGN SPECIFICATIONS. PRODUCTS FORMALLY ESCC, QML OR JAN QUALIFIED ARE DEEMED SUITABLE FOR USE IN AEROSPACE BY THE CORRESPONDING GOVERNMENTAL AGENCY.**

Resale of ST products with provisions different from the statements and/or technical features set forth in this document shall immediately void any warranty granted by ST for the ST product or service described herein and shall not create or extend in any manner whatsoever, any liability of ST.

ST and the ST logo are trademarks or registered trademarks of ST in various countries.

Information in this document supersedes and replaces all information previously supplied.

The ST logo is a registered trademark of STMicroelectronics. All other names are the property of their respective owners.

© 2014 STMicroelectronics - All rights reserved

STMicroelectronics group of companies

Australia - Belgium - Brazil - Canada - China - Czech Republic - Finland - France - Germany - Hong Kong - India - Israel - Italy - Japan - Malaysia - Malta - Morocco - Philippines - Singapore - Spain - Sweden - Switzerland - United Kingdom - United States of America

[www.st.com](http://www.st.com)

