

SLA707xM Series

February, 2006

■General Description

Combining low-power CMOS logic with high-current, high-voltage power FET outputs, the Series SLA707xM translator/drivers provide complete control and drive for a two-phase unipolar stepper motor with internal fixed off time and pulse-width modulation (PWM) control of the output current in a power multi-chip module (PMCM™).

There are no phase-sequence tables, high-frequency control lines, or complex interfaces to program. The CMOS logic section provides the sequencing logic, direction, control, synchronous/asynchronous PWM operation, and a "sleep" function. The minimum CLOCK input is an ideal fit for applications where a complex μ P is unavailable or overburdened. TTL or LSTTL may require the use of appropriate pull-up resistors to ensure a proper input-logic high. For PWM current control, the maximum output current is determined by the user's selection of a reference voltage and sensing resistor. The NMOS outputs are capable of sinking up to 1, 1.5, 2, or 3 A (depending on device) and withstanding 46 V in the off state.

Clamp diodes provide protection against inductive transients. Special power-up sequencing is not required.

Full- and Half-step operation are externally selectable for the SLA7070/71/72/73MR. Full-, Half-, quarter-, and eighth-, and sixteenth-step operation are externally selectable for the SLA7075/76/77/78MR.

Half-step excitation alternates between the one-phase and two-phase modes (A-AB-B-AB-A-AB-BAB), providing an eight-step sequence.

■Applications

- PPC
- Printer
- OA Equipment

■Features

- To 3 A Output Rating
- Internal Sequencer for Microstepping Operation
- PWM Constant-Current Motor Drive
- Cost-Effective, Multi-Chip Solution
- 100 V, Avalanche-Rated NMOS Outputs
- Low RDS(on) NMOS Outputs (150 milliohms typical)
- Advanced, Improved Body Diodes
- Inputs Compatible with 3.3 V or 5 V Control Signals
- Sleep Mode
- Internal Clamp Diodes

■Package—SLA23Pin



勝特力材料 886-3-5753170
 勝特力电子(上海) 86-21-34970699
 勝特力电子(深圳) 86-755-83298787
[Http://www.100y.com.tw](http://www.100y.com.tw)

■Key Specifications

- Motor Supply Voltage (VM): 44V max
- Load Supply Voltage (Vs): 10V to 44V
- Logic Supply Voltage (Vcc): 3V to 5.5V
- Output Current (Io): 1A(SLA7070MxRxx, SLA7075MxRxx)
 1.5A(SLA7071MxRxx, SLA7076MxRxx)
 2A(SLA7072MxRxx, SLA7077MxRxx)
 3A(SLA7073MxRxx, SLA7078MxRxx)

The x represents P, W, or R according to the functions (See App Note).

- Output Maximum Voltage (V_{DSS}): 100V min

Typical Connection

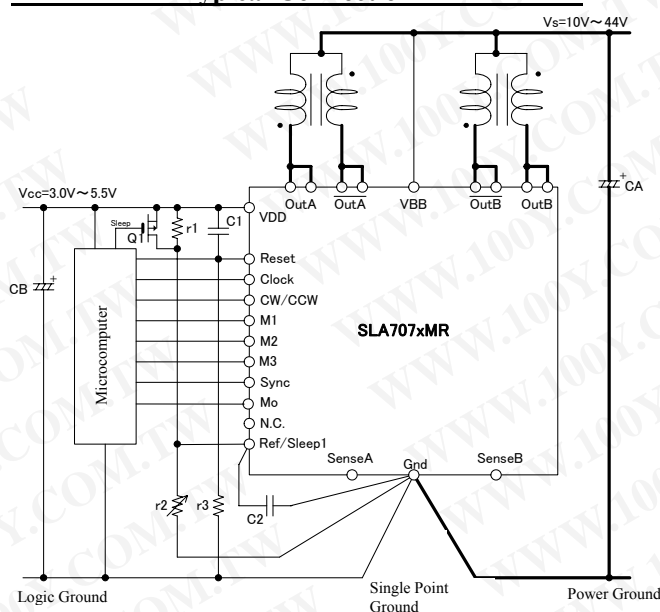

SLA707xM Series

February, 2006

Scope

The present specifications shall apply to a micro-stepping capable 2-phase unipolar stepper motor driver IC, SLA7077MR and shall apply to the devices compliant with RoHS Directive.

Lead part solder: Pb free. Inner solder: Containing Pb > 85%.

* Please refer to the electric characteristics in the application note for other devices of the series.

Outline

Type	Hybrid integrated circuit
Structure	Plastic molded (transfer mold)
Applications	To drive a 2-phase stepper motor. (Micro-Stepping Capable. PWM Constant-Current Control.)

Absolute maximum ratings

Parameter	Symbol	Ratings	Unit	Remarks
Load Supply Voltage	V_M	46	V	
Main Power Supply Voltage	V_{BB}	46	V	
Logic Supply Voltage	V_{DD}	7	V	
Output Current	I_O	2.0*	A	$V_{ref}=0.4V$, Mode F
Logic Input Voltage	V_{IN}	-0.3 to $V_{DD}+0.3$	V	
REF Input Voltage	V_{REF}	-0.3 to $V_{DD}+0.3$	V	
Sense Voltage	VRS	± 2	V	Except for $t_w < 1\mu s$
Power Dissipation	PD	4.7	W	At $T_a=25^\circ C$
		17	W	At $T_c=25^\circ C$
Junction Temperature	T_j	150	$^\circ C$	
Operating Temperature Range	T_a	-20 to 85	$^\circ C$	
Storage Temperature Range	T_{stg}	-30 to 150	$^\circ C$	

*Output current rating may be limited by duty cycle, ambient temperature, and heat sinking.

Under any conditions, do not exceed the specified junction temperature(T_j).

SLA707xM Series

February, 2006

Electrical characteristics

Recommendable Operating Range

Parameter	Symbol	Ratings		Unit	Remarks
		MIN	MAX		
Load Supply Voltage	V_M		44	V	
Main Power Supply Voltage Range	V_{BB}	10	44	V	
Logic Supply Voltage Range	V_{DD}	3.0	5.5	V	Please adjust the Vcc surge voltage to 0.5V or less.
REF Input Voltage Range	V_{REF}	0.04	0.4	V	The control current accuracy decreases in 0.1V or less.
Case Temperature	T_C		90	°C	12Pin temperature (With no Fin)

Electrical Characteristic ($T_a=25^\circ\text{C}$, $V_{BB}=24\text{V}$, $V_{DD}=5\text{V}$ Unless Otherwise Noted.)

Parameter	Symbol	Limits			Unit	Test Condition
		Min.	Typ.	Max.		
Main Power Supply Current	I_{BB}			15	mA	Regularity
	I_{BBS}			100	μA	at SLEEP operation
Logic Supply Current	I_{DD}			5	mA	
Drain-Source Breakdown	$V_{(BR)DS}$	100			V	$V_{BB}=44\text{V}$ $I_D=1\text{mA}$
Output On Resistance	$R_{DS(on)}$		0.25	0.4	Ω	$I_o=2\text{A}$
Body Diode Forward Voltage	V_F		0.95	1.2	V	$I_o=2\text{A}$
Maximum Clock Frequency	f_{clk}	250*			kHz	duty=50%
Logic Input Voltage	V_{LIL}			$0.25 V_{DD}$	V	
	V_{LIH}	$0.75 V_{DD}$			V	
Logic Input Current	I_{LIL}		± 1		μA	
	I_{LIH}		± 1		μA	
REF Input Voltage Range	V_{REF}	0		0.45	V	Stationary current control
	V_{REFS}	2.0		V_{DD}	V	at SLEEP operation

*Operation at a step frequency greater than the specified minimum value is possible but not warranted.

Note.

Negative current is defined as the outflowing current from the specified pin.

SLA707xM Series

February, 2006

REF Input Current	I_{REF}		± 10		μA	$V_{REF}=0$ to V_{DD}
Logic Output Voltage	V_{LOL}			1.25	V	$I_{LOL}=1.25mA$
	V_{LOH}	$V_{DD}-1.25$			V	$I_{LOH}=-1.25mA$
Logic Output Current	I_{LOL}			1.25	mA	
	I_{LOH}	-1.25			mA	

Operation at a step frequency greater than the specified minimum value is possible but not warranted.

Note.

Negative current is defined as the outflowing current from the specified pin.

Electrical Characteristic(continued) ($T_a=25^{\circ}C, V_{BB}=24V, V_{DD}=5V$ Unless Otherwise Noted.)

Characteristic	Symbol	Limits			Unit	Test Condition
		Min.	Typ.	Max.		
Sense Voltage	V_{SENSE}		0.3		V	$V_{REF}=0.3V$ Mode F
Current detection Resistance	R_s	0.199	0.205	0.211	Ω	
Step Reference Current Ratio	Mode F		100		%	$V_{REF}=0.04V$ to 0.4V
	Mode E		98.1		%	
	Mode D		95.7		%	
	Mode C		92.4		%	
	Mode B		88.2		%	
	Mode A		83.1		%	
	Mode 9		77.3		%	
	Mode 8		70.7		%	
	Mode 7		63.4		%	
	Mode 6		55.5		%	
	Mode 5		47.1		%	
	Mode 4		38.2		%	
	Mode 3		29.0		%	
Mode 2		19.5		%		
Mode 1		9.8		%		
Wake-Up time	t_{SE}	100			μs	Sleep1 & Sleep2
Switching Time	t_{pdon}		2.0		μs	Clock→Out ON
	t_{pdoff}		1.5		μs	Clock→Out OFF
PWM Minimum On Time	$t_{ON(min)}$		1.7		μs	
PWM OFF Time	t_{OFF1}		12		μs	Mode 8 to F
	t_{OFF2}		9		μs	Mode 4 to 7
	t_{OFF3}		7		μs	Mode 1 to 3

Note.

- Negative current is defined as coming out of the specified pin.

SLA707xM Series

February, 2006

Thermal Design Data

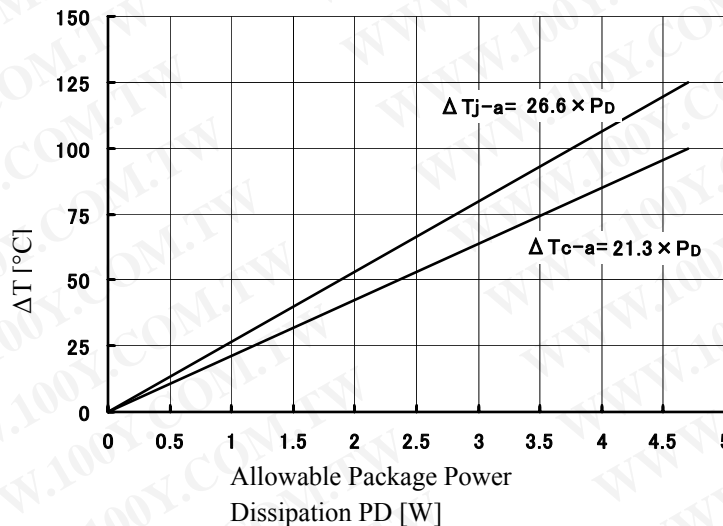

Truth Table

• Input Pin

Name	Low Level	High Level	Clock
Reset	Run	Logic Reset	-
CW/CCW	Forward (CW)	Reverse (CCW)	
M1 M2 M3	Micro-Stepping Operation Mode Setting		
Ref		Sleep Mode 1*	
Sync	Asynchronous PWM Operation	Synchronous PWM Operation	-

* With a setup of a sleep mode 1, the operation is "Output Disable" and "Sequencer Enable"

SLA707xM Series

February, 2006

Micro-Stepping Operation Mode Setting

Operation Mode	M1	M2	M3	Remarks
2 Phase(1 Step)	L	L	L	Mode 8 only
2Phase(1 Step)	H	L	L	Mode F only
1-2 Phase(1/2 Step)	L	H	L	Mode 8, F
1-2 Phase(1/2 Step)	H	H	L	Mode F
W1-2 Phase(1/4 Step)	L	L	H	Mode 4,8,C,F
W1-2 Phase(1/8 Step)	H	L	H	Mode 2,4,6,8,A,C,E,F
4W1-2 Phase(1/16 Step)	L	H	H	Mode 1 to F
Sleep Mode 2*	H	H	H	

* With a setup of a sleep mode 2, the operation is "Output Disable" and "Sequencer Hold".
Sleep mode 2 operates without depending on the Clock.

Output Pin

Pin Name	High Level	Low Level
Mo	Half-Step Position (Mode 8)	-

Logic Input Timing Requirements

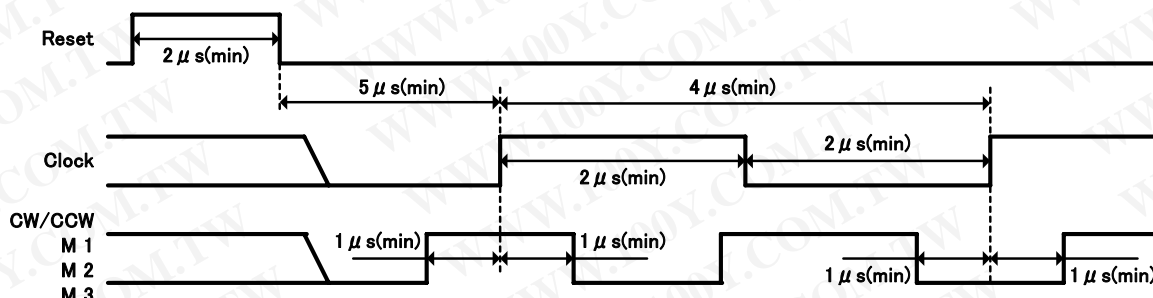

SLA707xM Series

February, 2006

Step Sequencing Chart

2Phase

Mode: 8 M1: L, M2: L, M3: L

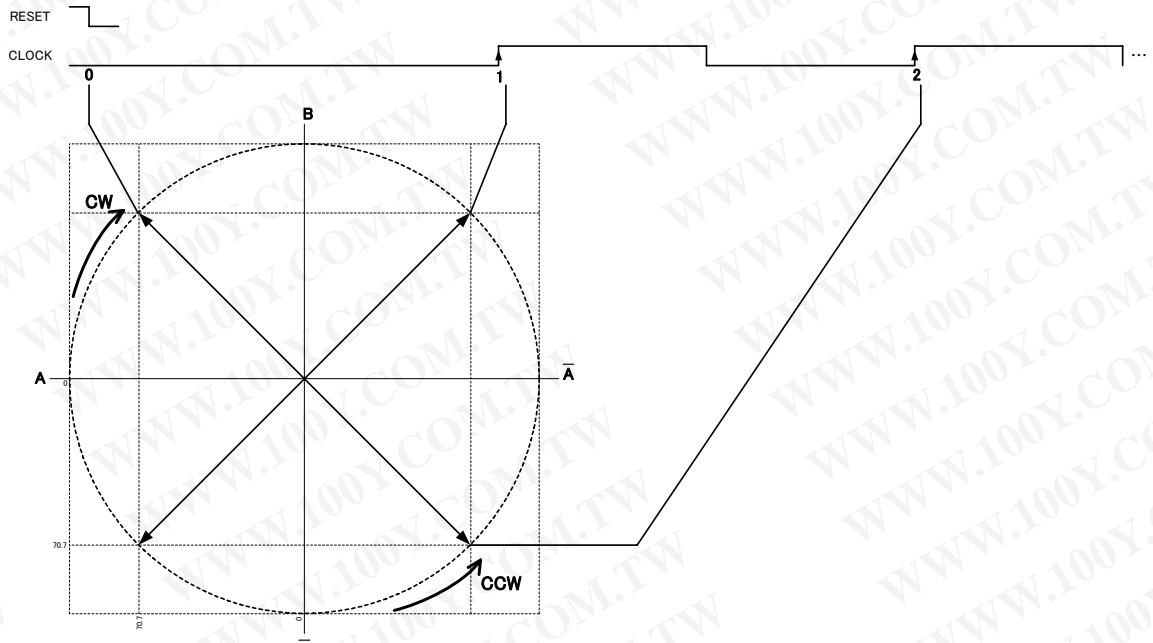

Mode: F M1: H, M2: L, M3: L

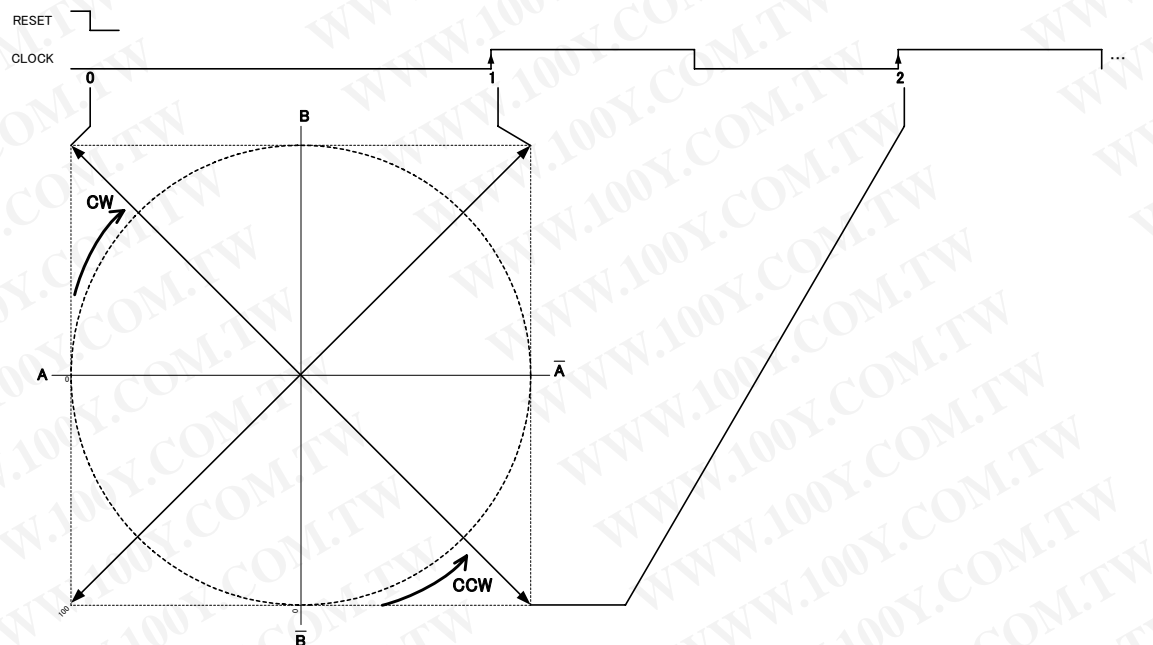

SLA707xM Series

February, 2006

1-2Phase

Mode: 8 \Leftrightarrow F M1: L, M2: H, M3: L

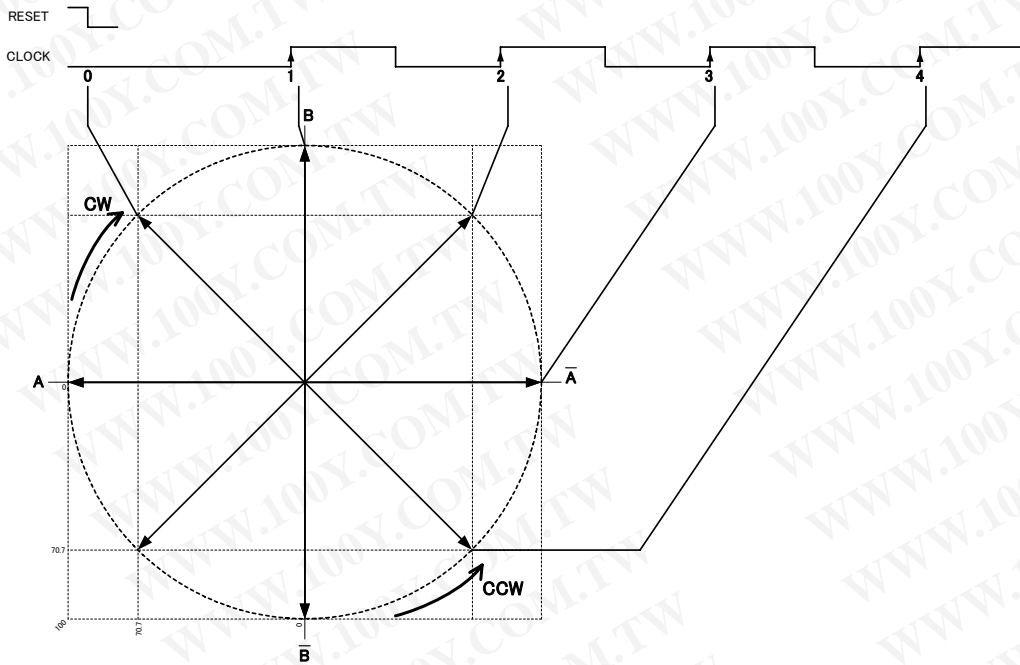

Mode: F M1:H, M2: H, M3: L

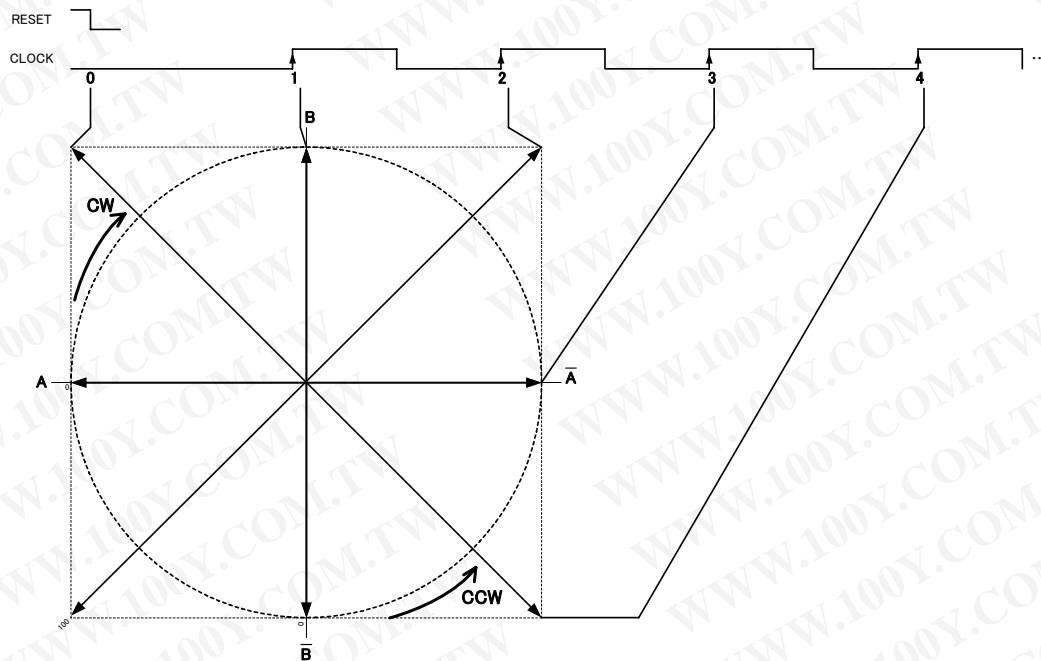

SLA707xM Series

February, 2006

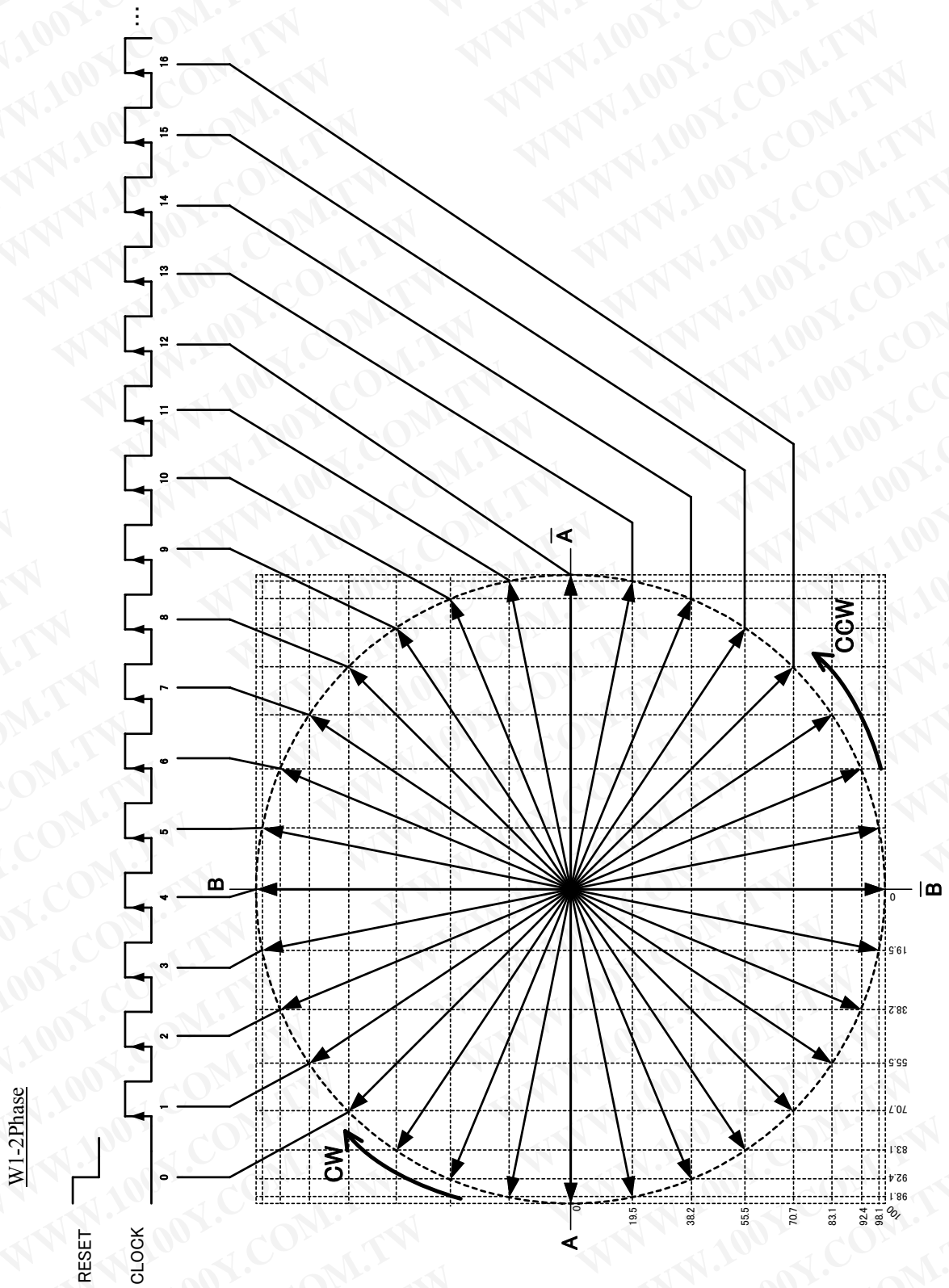

SLA707xM Series

February, 2006

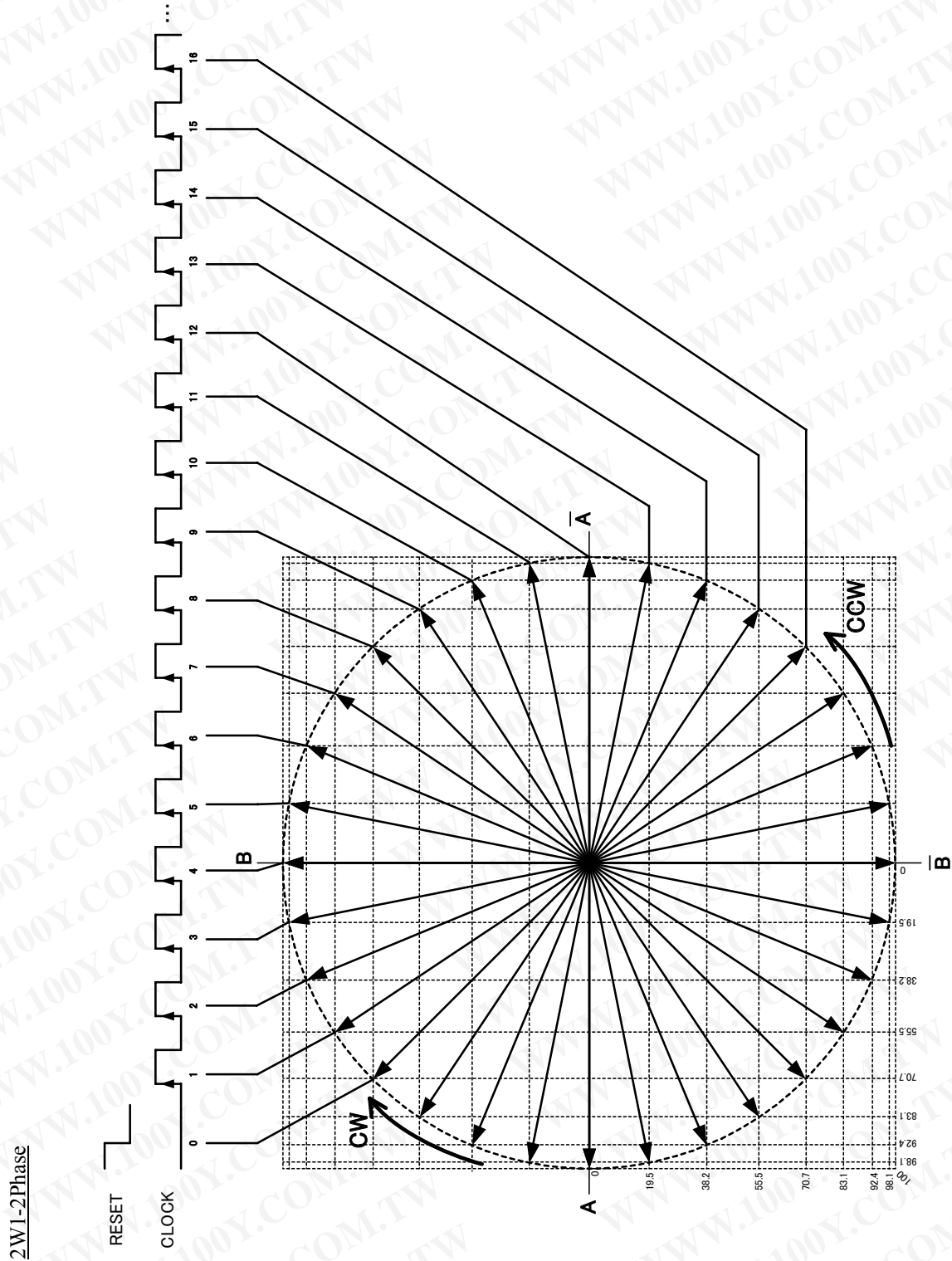

SLA707xM Series

February, 2006

4W1-2Phase

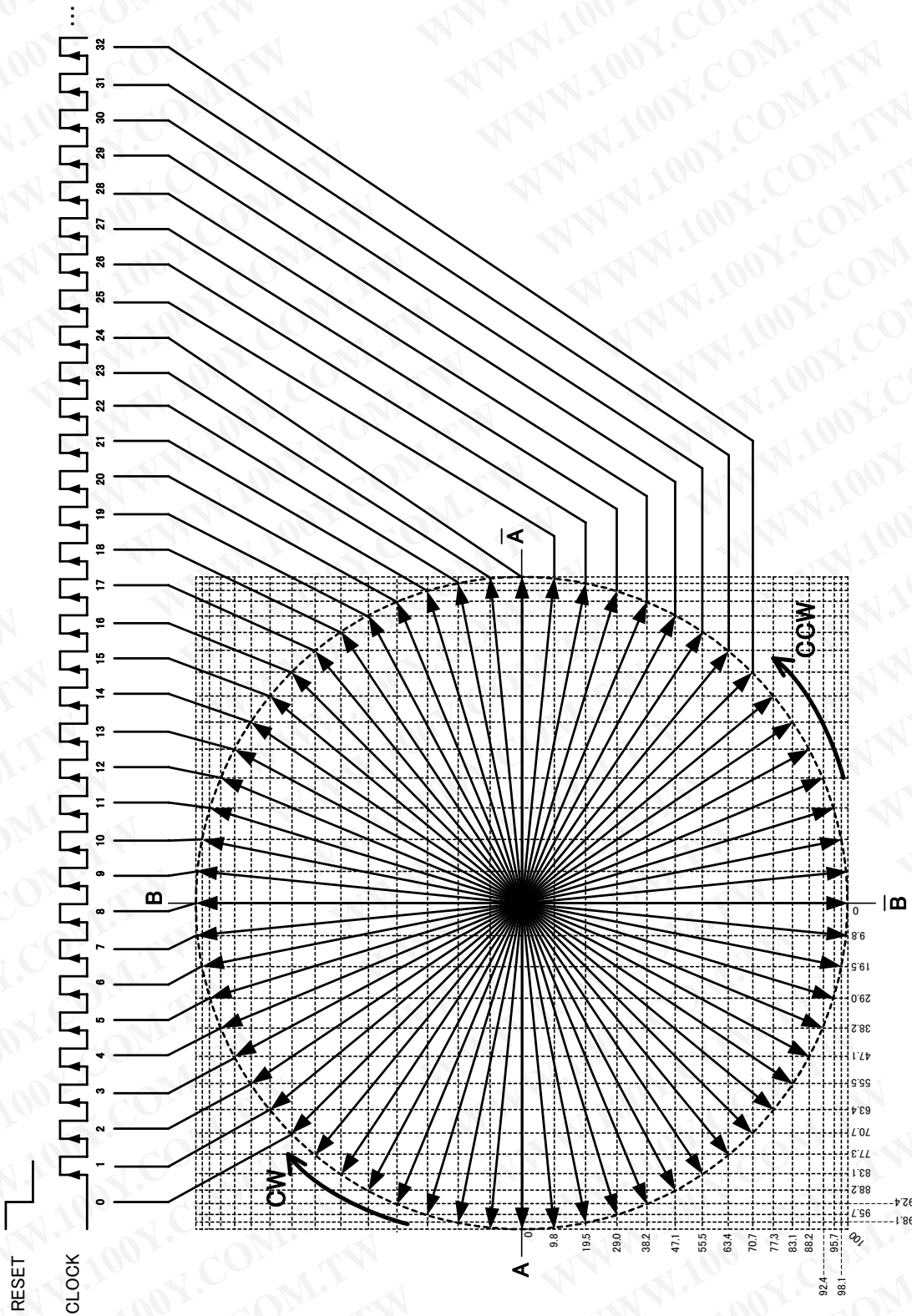

SLA707xM Series

Block diagram (Connection diagram)

Internal functional block diagram

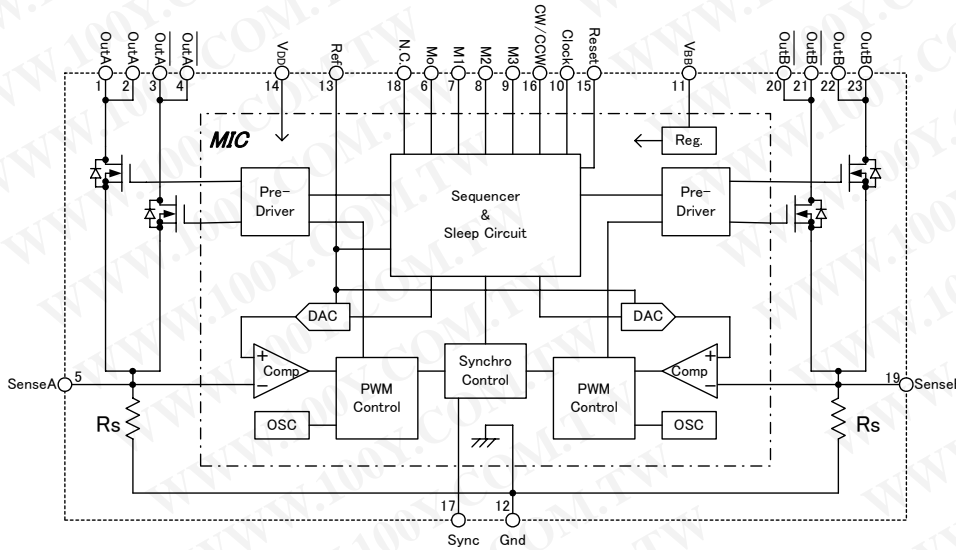

Pin Assignment (Terminal Functions)

Pin No.	Symbol	Function
1, 2	Out A	Phase A Output
3, 4	Out A/	Phase A/ Output
5	Sense A	Phase A Current Sense
6	Mo	Position Monitoring Output
7	M1	Micro-Stepping Operation Mode and Sleep Mode 2 Setting Input
8	M2	
9	M3	
10	Clock	Step Clock Input
11	V _{BB}	Main Power Supply (For Motor)
12	Gnd	GND
13	Ref	Control Current and Sleep Mode 1 Setting Input.
14	V _{DD}	Logic Supply
15	Reset	Reset Input for Logic Circuit
16	CW/CCW	Forward / Reverse Switch Input
17	Sync	PWM Chopping Function Select Input
18	N.C.	Non Connection
19	Sense B	Phase B Current Sense
20, 21	Out B/	Phase B/ Output
22, 23	Out B	Phase B Output

SLA707xM Series

February, 2006

Example application circuit

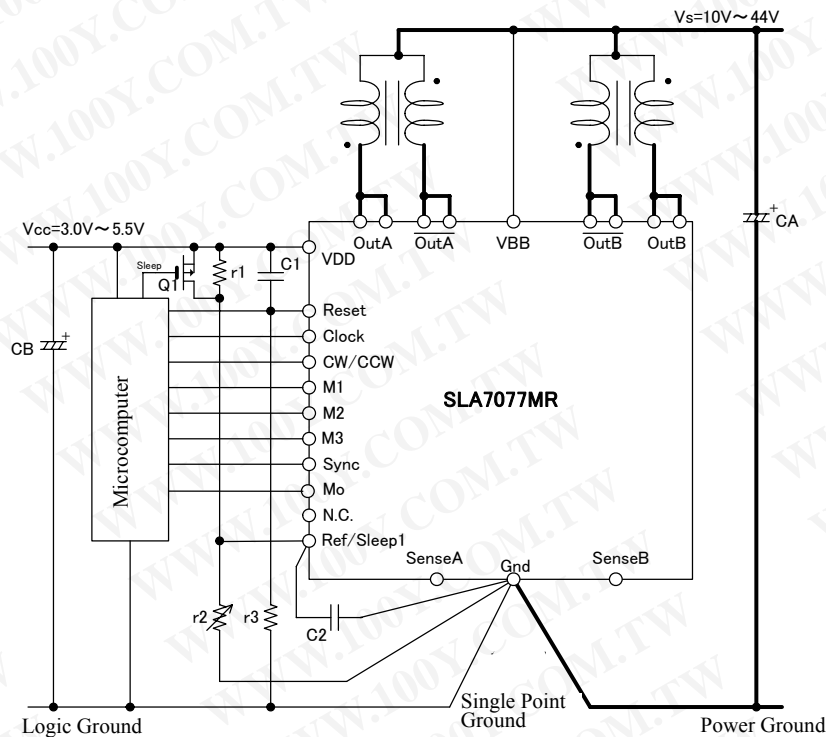

Reference constant

$$R_1 = 10\text{k}\Omega$$

$$R_2 = 5.1\text{k}\Omega(\text{VR})$$

$$R_3 = 10\text{k}\Omega$$

$$C_A = 100\mu\text{F}/50\text{V}$$

$$C_B = 10\mu\text{F}/10\text{V}$$

$$C_1 = 0.1\mu\text{F}$$

- Take precautions to avoid noise on the V_{DD} line:
Switching noise from PCB traces, where high current flows, to the V_{DD} line should be minimized because the noise level more than 0.5V on the V_{DD} line may cause malfunctioning operation.
The tip for avoiding such problem is to separate the logic GND (S-GND) and the power GND (P-GND) on the PCB, and then connect them together at IC GND pin (pin 12).

SLA707xM Series

February, 2006

Package information

Package type, physical dimensions and Material

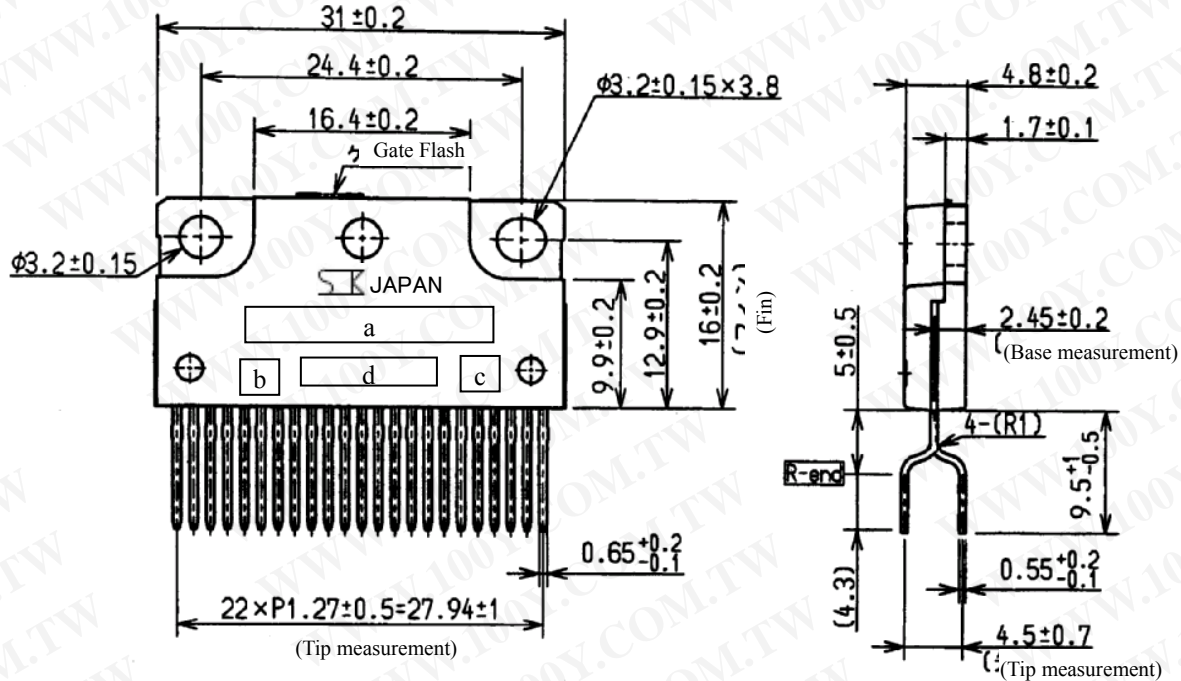

- a. Part Number (1) SLA707xMR*
- b. Part Number (2) W B (Marked per functions.)*
- c. Part Number (3) P (Marked per functions.)*
- d. Lot Number
 - 1st letter The last digit of year
 - 2nd letter Month
 - 1 to 9 : Arabic Numerals for Jan. to Sep.
 - October : O
 - November : N
 - December : D
 - 3rd & 4th letter Day
 - 01 to 31 : Arabic Numerals

Dimensions in millimeters

Material of terminal : Cu

Treatment of terminal : Ni plating + solder dip (Pb Free)

Appearance

The body shall be clean and shall not bear any stain, rust or flaw.

Marking

The part number and lot number shall be clearly marked in white.

* The letter x in Part Number (1) represents one number from 0 to 3 and 5 to 8 according to the combination of the current rating and sequencer.

The letter P, R, W, B represent the functions built-in. (No marking for non built-in functions.)

SLA707xM Series

February, 2006

Packing specifications

1

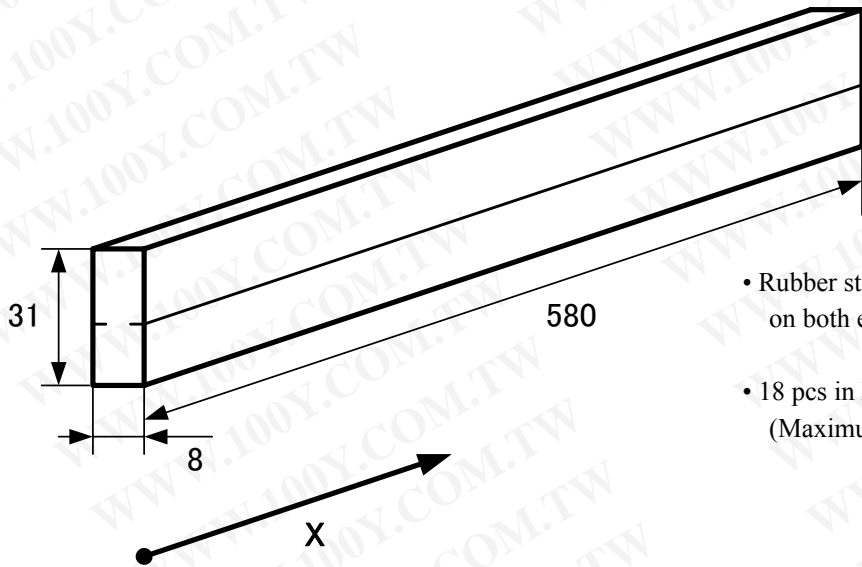

- Rubber stoppers are provided on both ends of a stick.
- 18 pcs in X direction (Maximum: 18 pcs per stick)

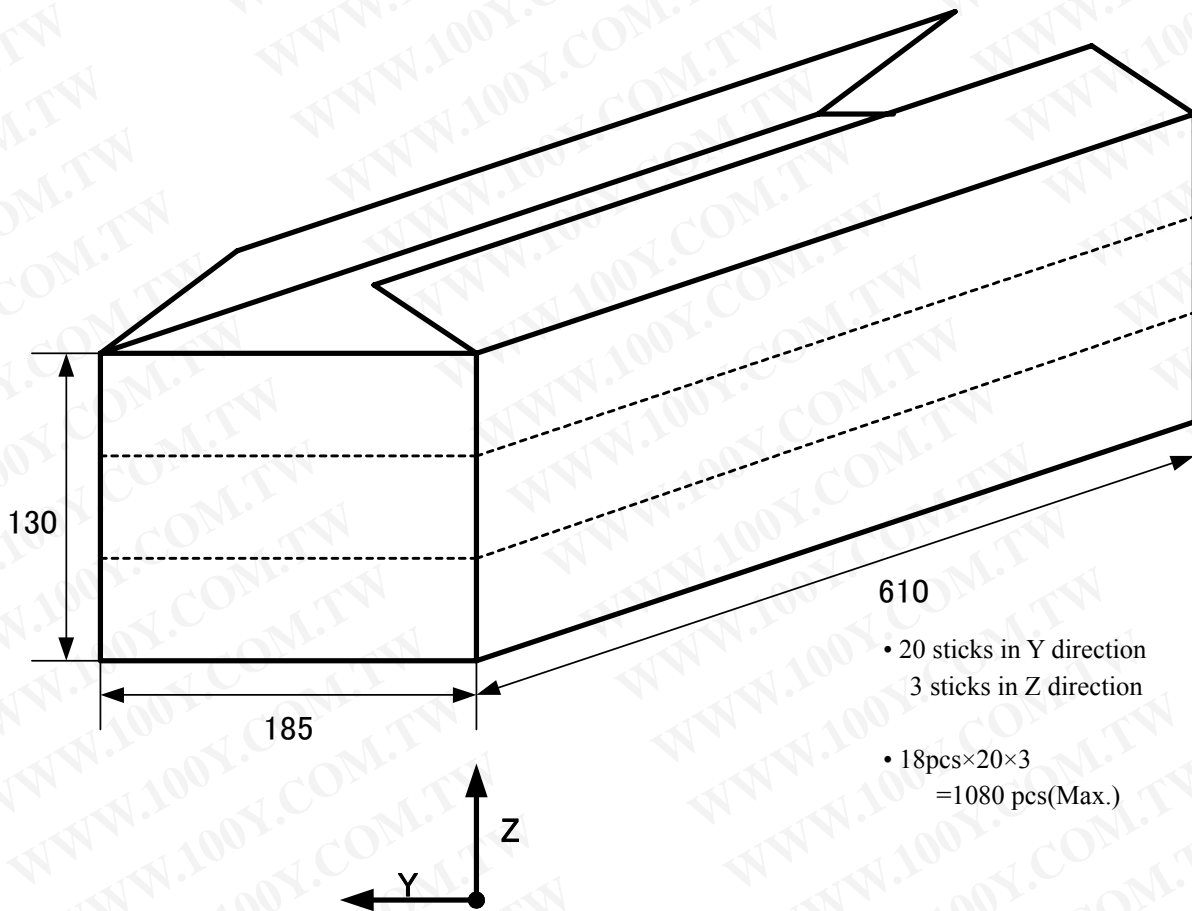

- 610
- 20 sticks in Y direction
3 sticks in Z direction
 - 18pcs×20×3
=1080 pcs(Max.)

Dimensions in millimeters

SLA707xM Series

February, 2006

Cautions and warnings

The calculation of control current

SLA707xMR control current I_o (at Mode F) is calculated as follows:

$$I_o = \frac{V_{REF}}{R_s}$$

Setting the REF voltage more than 2V activates the sleep mode 1 (all outputs are in OFF state).

Even in this case, the internal logic circuit is alive.

Logic input/output (RESET, CLOCK, CW/CCW, M1, M2, M3, SYNC, Mo)

- The timing shown below shall comply with the "Logic input timing".
- The rising edge timing of CW/CCW, M1, M2, M3 and CLOCK input
- The RESET release timing (=the falling edge on RESET input) and the rising edge timing of CLOCK input
- *In case the above does not comply with the "Logic input timing", the device may operate with an unexpected sequence.
- Be sure not to leave the logic inputs (RESET, CLOCK, CW/CCW, M1, M2, M3, SYNC) open.
Be sure to connect the unused logic inputs to VDD or GND.
- *In case any of the logic inputs are left "OPEN", malfunction may occur due to external noises.
- When the logic output (Mo) is not used, be sure to keep it "OPEN".
- *In case it is connected to VDD or GND, it may cause the device's deterioration or/and breakdown.

Mounting on a heat sink

1) Recommended Mounting Torque (on an External Heat sink) 0.490 to 0.822N•m

2) Recommended Silicone

G746	{SHIN-ETSU CHEMICAL}
YG6260	{TOSHIBA SILICONE}
SC102	{DOW CORNING TORAY SILICONE}

SLA707xM Series

February, 2006

Notice

This device has C-MOS inputs. Please note the following contents.

- When a static electricity is liable to be troublesome, especially in winter, be sure to control the room humidity properly.
- Be sure to take some proper measures for wirings from the IC input pins and for assembly processes in order not to apply static charges to IC leads. PC board pins should be shorted together to keep them in the same potential to avoid this kind of trouble.

SLA707xM Series

February, 2006

<Worldwide Contacts>

Asia Pacific

China

Sanken Electric Hong Kong Co., Ltd.

Suite 1026 Ocean Centre, Canton Road, Tsimshatsui, Kowloon, Hong Kong

Tel: 852-2735-5262

Fax: 852-2735-5494

Sanken Electric (Shanghai) Co., Ltd.

Room3202, Maxdo Centre, Xingyi Road 8, Changning district, Shanghai, China

Tel: 86-21-5208-1177

Fax: 86-21-5208-1757

Taiwan Sanken Electric Co., Ltd.

Room 1801, 18th Floor, 88 Jung Shiau East Road, Sec. 2, Taipei 100, Taiwan R.O.C.

Tel: 886-2-2356-8161

Fax: 886-2-2356-8261

India

Saket Devices Pvt. Ltd.

Office No.13, First Floor, Bandal - Dhankude Plaza, Near PMT Depot, Paud Road, Kothrud, Pune - 411 038, India

Tel: 91-20-5621-2340

91-20-2528-5449

Fax: 91-20-2528-5459

Japan

Sanken Electric Co., Ltd. Overseas Sales Headquarters

Metropolitan Plaza Bldg. 1-11-1 Nishi-Ikebukuro, Toshima-ku, Tokyo 171-0021, Japan

Tel: 81-3-3986-6164

Fax: 81-3-3986-8637

Korea

Sanken Electric Korea Co., Ltd.

Mirae Asset Life Bldg. 6F, 168 Kongduk-dong, Mapo-ku, Seoul, 121-705, Korea

Tel: 82-2-714-3700

Fax: 82-2-3272-2145

Singapore

Sanken Electric Singapore Pte. Ltd.

150 Beach Road, #14-03 The Gateway West, Singapore 189720

Tel: 65-6291-4755

Fax: 65-6297-1744

SLA707xM Series

February, 2006

Europe

United Kingdom

SanKen Power Systems (UK) Limited

Pencoed Technology Park, Pencoed, Bridgend CF35 5HY. UK

Tel: 44-1656-869-100

Fax: 44-1656-869-162

North America

United States

Allegro MicroSystems, Inc.

115 Northeast Cutoff, Worcester, Massachusetts 01606, U.S.A.

Tel: 1-508-853-5000

Fax: 1-508-853-3353

Allegro MicroSystems, Inc. (Southern California)

14 Hughes Street, Suite B105, Irvine, CA 92618

Tel: 1-949-460-2003

Fax: 1-949-460-7837

SLA707xM Series

February, 2006

CAUTION / WARNING

- The information in this publication has been carefully checked and is believed to be accurate; however, no responsibility is assumed for inaccuracies.
- SanKen reserves the right to make changes without further notice to any products herein in the interest of improvements in the performance, reliability, or manufacturability of its products.

Before placing an order, SanKen advises its customers to obtain the latest version of the relevant information to verify that the information being relied upon is current.

- Application and operation examples described in this catalog are quoted for the sole purpose of reference for the use of the products herein and SanKen can assume no responsibility for any infringement of industrial property rights, intellectual property rights or any other rights of SanKen or any third party which may result from its use.
- When using the products herein, the applicability and suitability of such products for the intended purpose or object shall be reviewed at the users' responsibility.
- Although SanKen undertakes to enhance the quality and reliability of its products, the occurrence of failure and defect of semiconductor products at a certain rate is inevitable. Users of SanKen products are requested to take, at their own risk, preventative measures including safety design of the equipment or systems against any possible injury, death, fires or damages to the society due to device failure or malfunction.
- SanKen products listed in this catalog are designed and intended for the use as components in general purpose electronic equipment or apparatus (home appliances, office equipment, telecommunication equipment, measuring equipment, etc.). Before placing an order, the user's written consent to the specifications is requested.

When considering the use of SanKen products in the applications where higher reliability is required (transportation equipment and its control systems, traffic signal control systems or equipment, fire/crime alarm systems, various safety devices, etc.), please contact your nearest SanKen sales representative to discuss and obtain written confirmation of your specifications. The use of SanKen products without the written consent of SanKen in the applications where extremely high reliability is required (aerospace equipment, nuclear power control systems, life support systems, etc.) is strictly prohibited.

- Anti radioactive ray design is not considered for the products listed herein.
- This publication shall not be reproduced in whole or in part without prior written approval from SanKen.
- This is notification that you, as purchaser of the products/technology, are not allowed to perform any of the following:
 1. Resell or retransfer these products/technology to any party intending to disturb international peace and security.
 2. Use these products/technology yourself for activities disturbing international peace and security.
 3. Allow any other party to use these products/technology for activities disturbing international peace and security.

Also, as purchaser of these products/technology, you agree to follow the procedures for the export or transfer of these products/technology, under the Foreign Exchange and Foreign Trade Law, when you export or transfer the products/technology abroad.