

2-Phase Stepper Motor Unipolar Driver ICs

■Absolute Maximum Ratings

(Ta=25°C)

Parameter	Symbol	Ratings			Units
		SLA7027MU	SLA7024M	SLA7026M	
Motor supply voltage	V _{CC}	46			V
FET Drain-Source voltage	V _{DSS}	100			V
Control supply voltage	V _S	46			V
TTL input voltage	V _{IN}	7			V
Reference voltage	V _{REF}	2			V
Output current	I _O	1	1.5	3	A
Power dissipation	P _{D1}	4.5 (Without Heatsink)			W
	P _{D2}	35 (T _C =25°C)			W
Channel temperature	T _{ch}	+150			°C
Storage temperature	T _{stg}	-40 to +150			°C

■Electrical Characteristics

Parameter	Symbol	Ratings									Units
		SLA7027MU			SLA7024M			SLA7026M			
		min	typ	max	min	typ	max	min	typ	max	
Control supply current	I _S		10	15		10	15		10	15	mA
	Condition	V _S =44V			V _S =44V			V _S =44V			
Control supply voltage	V _S	10	24	44	10	24	44	10	24	44	V
FET Drain-Source voltage	V _{DSS}	100			100			100			V
	Condition	V _S =44V, I _{DSS} =250μA			V _S =44V, I _{DSS} =250μA			V _S =44V, I _{DSS} =250μA			
FET ON voltage	V _{DS}			0.85			0.6			0.85	V
	Condition	I _D =1A, AV _S =14V			I _D =1A, V _S =14V			I _D =3A, V _S =14V			
FET drain leakage current	I _{DSS}			4			4			4	mA
	Condition	V _{DSS} =100V, V _S =44V			V _{DSS} =100V, V _S =44V			V _{DSS} =100V, V _S =44V			
FET diode forward voltage	V _{SD}			1.2			1.1			2.3	V
	Condition	I _D =1A			I _D =1A			I _D =3A			
TTL input current	I _{IH}			40			40			40	μA
	Condition	V _{IH} =2.4V, V _S =44V			V _{IH} =2.4V, V _S =44V			V _{IH} =2.4V, V _S =44V			
	I _{IL}			-0.8			-0.8			-0.8	mA
	Condition	V _{IL} =0.4V, V _S =44V			V _{IL} =0.4V, V _S =44V			V _{IL} =0.4V, V _S =44V			
TTL input voltage (Active High)	V _{IH}	2			2			2			V
	Condition	I _D =1A			I _D =1A			I _D =3A			
	V _{IL}			0.8			0.8			0.8	
	Condition	V _{DSS} =100V			V _{DSS} =100V			V _{DSS} =100V			
TTL input voltage (Active Low)	V _{IH}	2			2			2			V
	Condition	V _{DSS} =100V			V _{DSS} =100V			V _{DSS} =100V			
	V _{IL}			0.8			0.8			0.8	
	Condition	I _D =1A			I _D =1A			I _D =3A			
Switching time	T _r		0.5			0.5			0.5		μs
	Condition	V _S =24V, I _D =0.8A			V _S =24V, I _D =1A			V _S =24V, I _D =1A			
	T _{stg}		0.7			0.7			0.7		
	Condition	V _S =24V, I _D =0.8A			V _S =24V, I _D =1A			V _S =24V, I _D =1A			
	T _f		0.1			0.1			0.1		
	Condition	V _S =24V, I _D =0.8A			V _S =24V, I _D =1A			V _S =24V, I _D =1A			

勝特力材料 886-3-5753170
 勝特力电子(上海) 86-21-34970699
 勝特力电子(深圳) 86-755-83298787
[Http://www.100y.com.tw](http://www.100y.com.tw)

勝特力材料 886-3-5753170
 勝特力电子(上海) 86-21-34970699
 勝特力电子(深圳) 86-755-83298787
[Http://www.100y.com.tw](http://www.100y.com.tw)

Internal Block Diagram

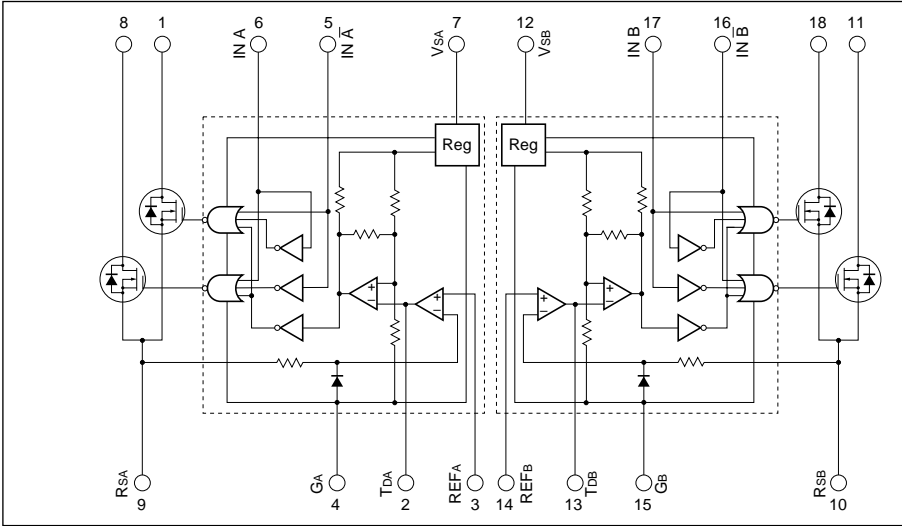

1, 8, 11, 18pin
Description of pins

	Excitation input	
	Active H	Active L
Pin 1	OUT _A	OUT _A
Pin 8	OUT _A	OUT _A
Pin 11	OUT _B	OUT _B
Pin 18	OUT _B	OUT _B

Diagram of Standard External Circuit(Recommended Circuit Constants)

Active High

Excitation signal time chart

2-phase excitation

clock	0	1	2	3	0	1
IN _A	H	L	L	H	H	L
IN _A	L	H	H	L	L	H
IN _B	H	H	L	L	H	H
IN _B	L	L	H	H	L	L

Active Low

Excitation signal time chart

2-phase excitation

clock	0	1	2	3	0	1
IN _A	L	H	H	L	L	H
IN _A	H	L	L	H	H	L
IN _B	L	L	H	H	L	L
IN _B	H	H	L	L	H	H

1-2 phase excitation

clock	0	1	2	3	4	5	6	7	0	1	2	3
IN _A	H	H	L	L	L	L	L	H	H	H	L	L
IN _A	L	L	L	H	H	H	L	L	L	L	L	H
IN _B	L	H	H	H	L	L	L	L	L	H	H	H
IN _B	L	L	L	L	L	H	H	H	L	L	L	L

1-2 phase excitation

clock	0	1	2	3	4	5	6	7	0	1	2	3
IN _A	L	L	H	H	H	H	H	L	L	L	H	H
IN _A	H	H	H	L	L	L	H	H	H	H	L	L
IN _B	H	L	L	L	H	H	H	H	H	L	L	L
IN _B	H	H	H	H	L	L	L	L	H	H	H	H

r₁ : 510Ω
 r₂ : 100Ω (VR)
 r₃ : 47kΩ
 r₄ : 47kΩ
 r₅ : 2.4kΩ
 r₆ : 2.4kΩ
 C₁ : 470pF
 C₂ : 470pF
 C₃ : 2200pF
 C₄ : 2200pF
 R_s : 1Ω typ(7024M)
 (1 to 2W) 0.68Ω typ(7026M)
 1.8Ω typ(7027MU)

External Dimensions

(Unit: mm)

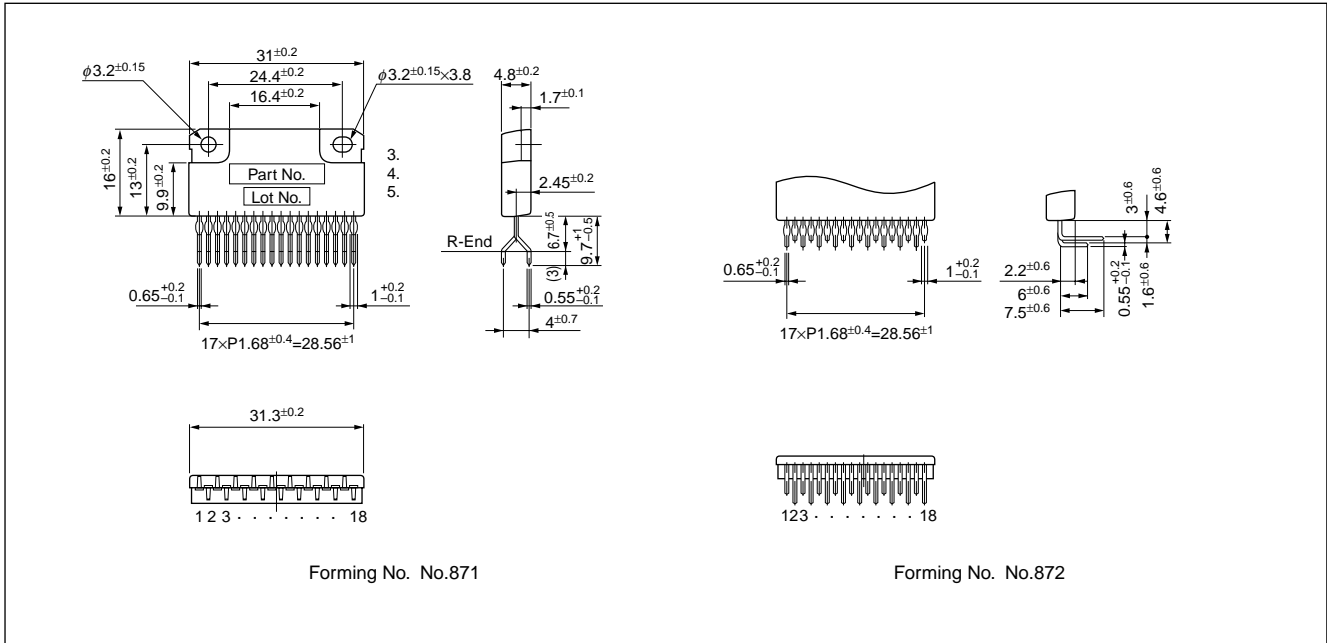

勝特力材料 886-3-5753170
 勝特力电子(上海) 86-21-34970699
 勝特力电子(深圳) 86-755-83298787
[Http://www.100y.com.tw](http://www.100y.com.tw)

Application Notes

■Determining the Output Current

Fig. 1 shows the waveform of the output current (motor coil current). The method of determining the peak value of the output current (I_o) based on this waveform is shown below.

(Parameters for determining the output current I_o)

V_b : Reference supply voltage

r_1, r_2 : Voltage-divider resistors for the reference supply voltage

R_s : Current sense resistor

(1) Normal rotation mode

I_o is determined as follows when current flows at the maximum level during motor rotation. (See Fig.2.)

$$I_o \cong \frac{r_2}{r_1+r_2} \cdot \frac{V_b}{R_s} \dots\dots\dots (1)$$

(2) Power down mode

The circuit in Fig.3 (r_x and T_r) is added in order to decrease the coil current. I_o is then determined as follows.

$$I_{OPD} \cong \frac{1}{1 + \frac{r_1(r_2+r_x)}{r_2 \cdot r_x}} \cdot \frac{V_b}{R_s} \dots\dots\dots (2)$$

Equation (2) can be modified to obtain equation to determine r_x .

$$r_x = \frac{1}{\frac{1}{r_1} \left(\frac{V_b}{R_s \cdot I_{OPD}} - 1 \right) - \frac{1}{r_2}}$$

Fig. 4 and 5 show the graphs of equations (1) and (2) respectively.

勝特力材料 886-3-5753170
勝特力电子(上海) 86-21-34970699
勝特力电子(深圳) 86-755-83298787
[Http://www.100y.com.tw](http://www.100y.com.tw)

Fig. 1 Waveform of coil current (Phase A excitation ON)

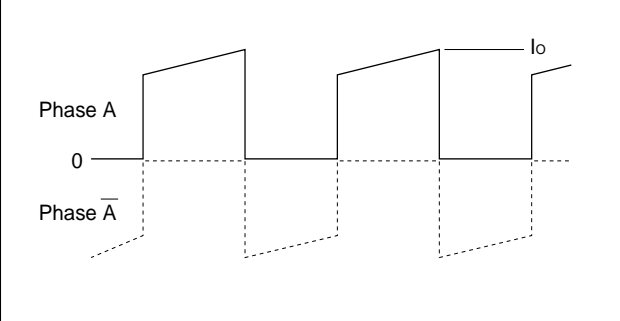

Fig. 2 Normal mode

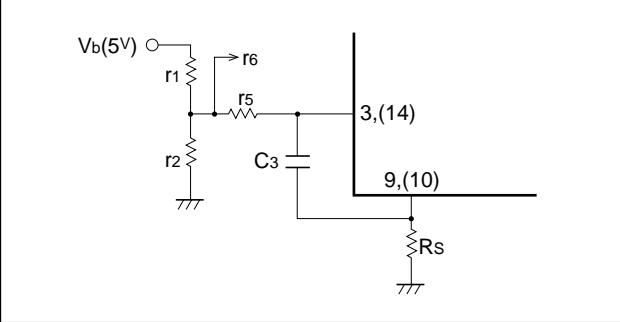

Fig. 3 Power down mode

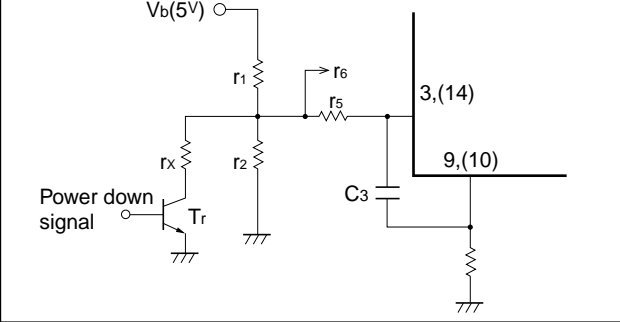

Fig. 4 Output current I_o vs. Current sense resistor R_s

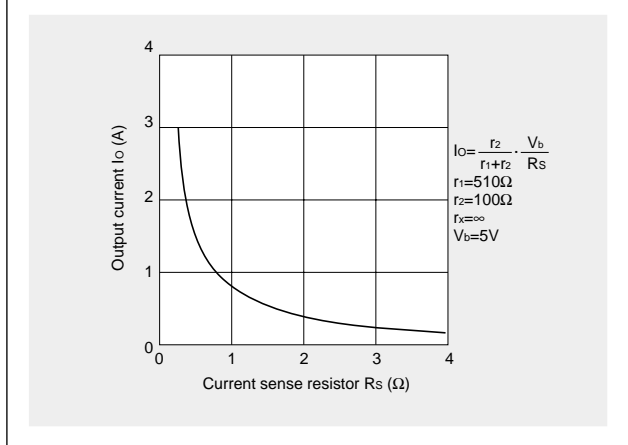
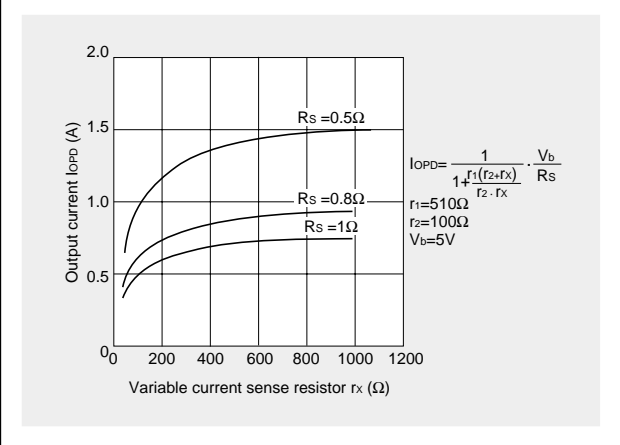

Fig. 5 Output current I_{OPD} vs. Variable current sense resistor r_x



(NOTE)

Ringing noise is produced in the current sense resistor R_s when the MOSFET is switched ON and OFF by chopping. This noise is also generated in feedback signals from R_s which may therefore cause the comparator to malfunction. To prevent chopping malfunctions, $r_5(r_6)$ and $C_3(C_4)$ are added to act as a noise filter.

However, when the values of these constants are increased, the response from R_s to the comparator becomes slow. Hence the value of the output current I_o is somewhat higher than the calculated value.

Determining the chopper frequency

Determining T_{OFF}

The SLA7000M series are self-excited choppers. The chopping OFF time T_{OFF} is fixed by r_3/C_1 and r_4/C_2 connected to terminal Td.

T_{OFF} can be calculated using the following formula:

$$T_{OFF} \approx -r_3 \cdot C_1 \ln \left(1 - \frac{2}{V_b}\right) = -r_4 \cdot C_2 \ln \left(1 - \frac{2}{V_b}\right)$$

The circuit constants and the T_{OFF} value shown below are recommended.

$$T_{OFF} = 12\mu s \text{ at } r_3=47k\Omega, C_1=500pF, V_b=5V$$

Fig. 6 Chopper frequency vs. Motor coil resistance

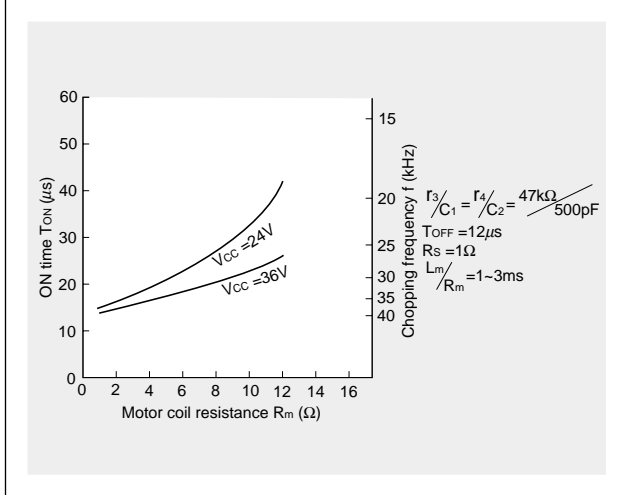

Chopper frequency vs. Supply voltage

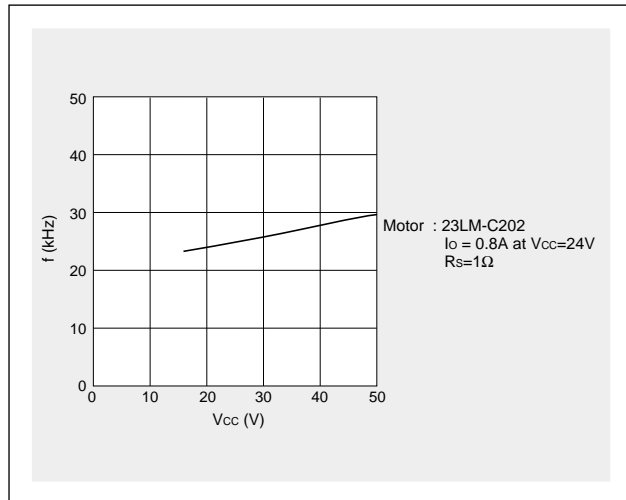

Chopper frequency vs. Output current

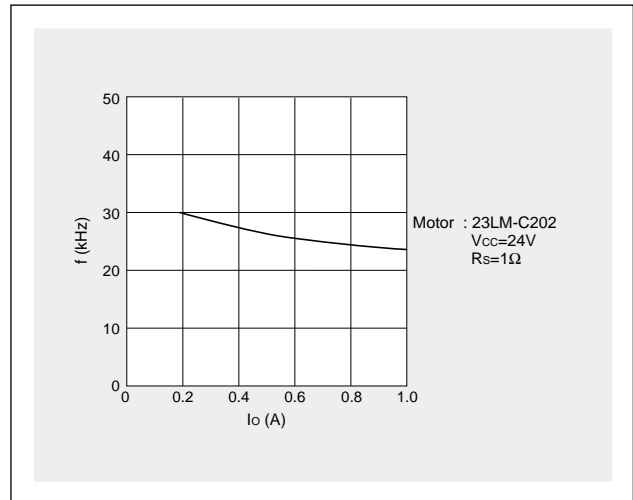

勝特力材料 886-3-5753170
 勝特力电子(上海) 86-21-34970699
 勝特力电子(深圳) 86-755-83298787
[Http://www.100y.com.tw](http://www.100y.com.tw)

Thermal Design

An outline of the method for calculating heat dissipation is shown below.

(1) Obtain the value of P_H that corresponds to the motor coil current I_o from Fig. 7 "Heat dissipation per phase P_H vs. Output current I_o ."

(2) The power dissipation P_{diss} is obtained using the following formula.

2-phase excitation: $P_{diss} \cong 2P_H + 0.015 \times V_s$ (W)

1-2 phase excitation: $P_{diss} \cong \frac{3}{2} P_H + 0.015 \times V_s$ (W)

(3) Obtain the temperature rise that corresponds to the calculated value of P_{diss} from Fig. 8 "Temperature rise."

Fig. 7 Heat dissipation per phase P_H vs. Output current I_o

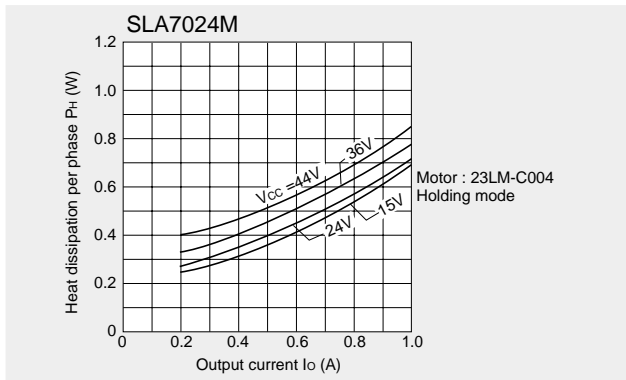
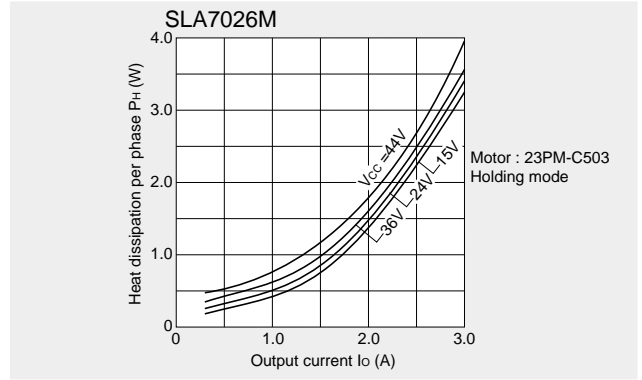
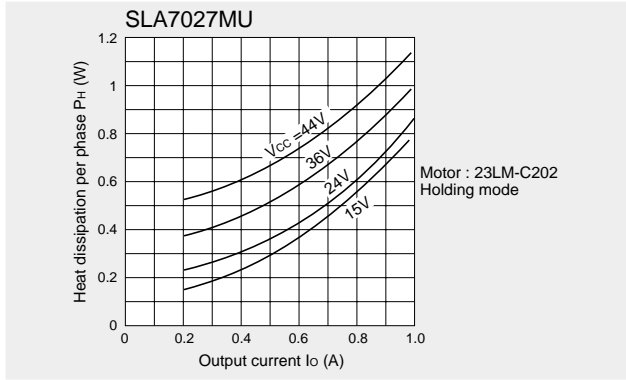
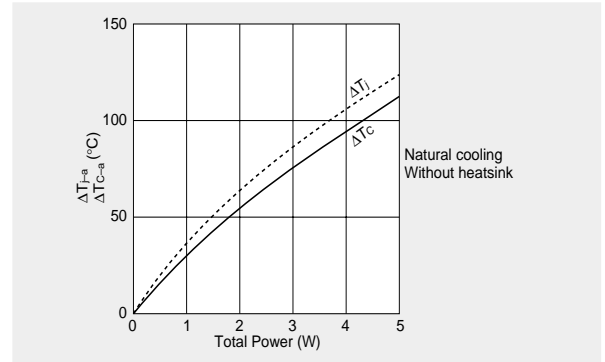
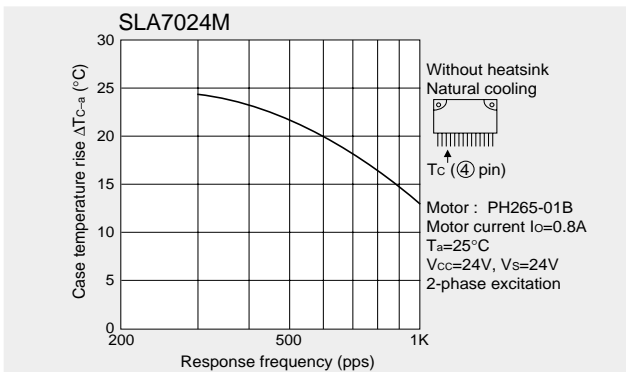
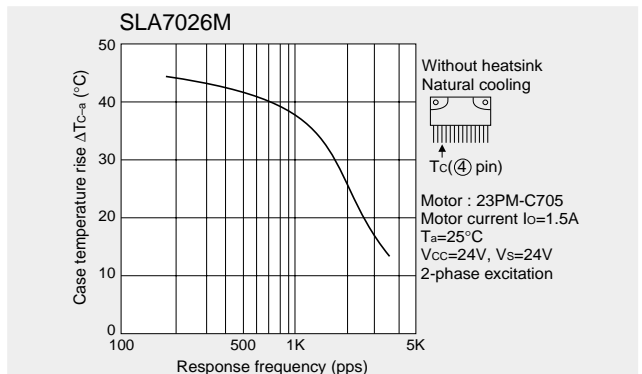
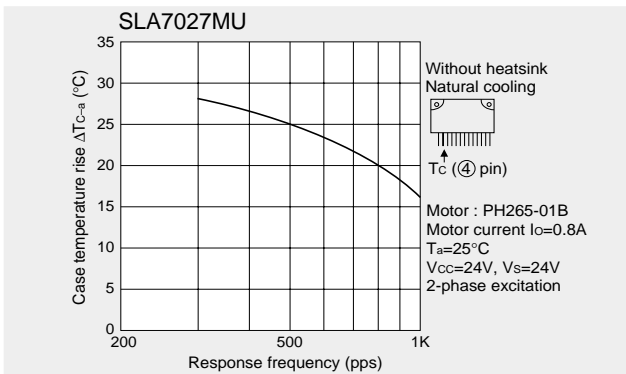

Fig. 8 Temperature rise



Thermal characteristics



勝特力材料 886-3-5753170
 勝特力电子(上海) 86-21-34970699
 勝特力电子(深圳) 86-755-83298787
[Http://www.100y.com.tw](http://www.100y.com.tw)

Supply Voltage V_{CC} vs. Supply Current I_{CC}

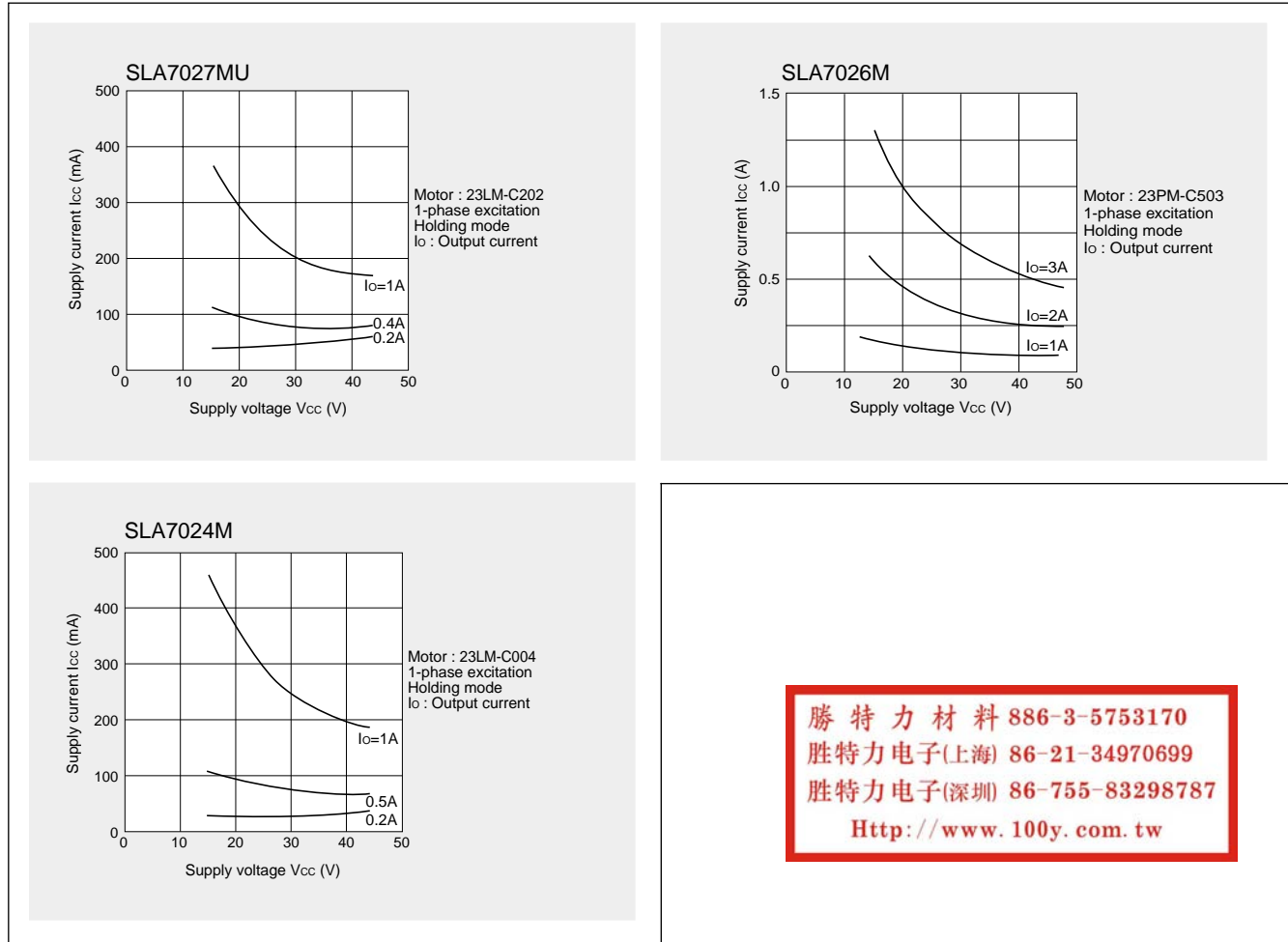

勝特力材料 886-3-5753170
 勝特力电子(上海) 86-21-34970699
 勝特力电子(深圳) 86-755-83298787
[Http://www.100y.com.tw](http://www.100y.com.tw)

Note

The excitation input signals of the SLA7027MU, SLA7024M and SLA7026M can be used as either Active High or Active Low. Note, however, that the corresponding output (OUT) changes depending on the input (IN).

Active High

Input	Corresponding output
IN_A (pin6)	OUT_A (pin1)
$IN_{\bar{A}}$ (pin5)	$OUT_{\bar{A}}$ (pin8)
IN_B (pin17)	OUT_B (pin11)
$IN_{\bar{B}}$ (pin16)	$OUT_{\bar{B}}$ (pin18)

Active Low

Input	Corresponding output
IN_A (pin6)	OUT_A (pin8)
$IN_{\bar{A}}$ (pin5)	$OUT_{\bar{A}}$ (pin1)
IN_B (pin17)	OUT_B (pin18)
$IN_{\bar{B}}$ (pin16)	$OUT_{\bar{B}}$ (pin11)