

1.5A High-Speed 30V MOSFET Drivers

Features

- High Peak Output Current – 1.5A
- Wide Input Supply Voltage Operating Range:
 - 4.5V to 30V
- High Capacitive Load Drive Capability:
 - 1000 pF in 25 nsec
- Short Delay Times – <78 nsec Typ.
- Low Supply Current:
 - With Logic '1' Input – 2.5 mA
 - With Logic '0' Input – 300 μ A
- Low Output Impedance – 7 Ω
- Latch-Up Protected: Will Withstand >300 mA Reverse Current
- ESD Protected – 4 kV

Applications

- Small Motor Drive
- Power MOSFET Driver
- Driving Bipolar Transistors

Package Types

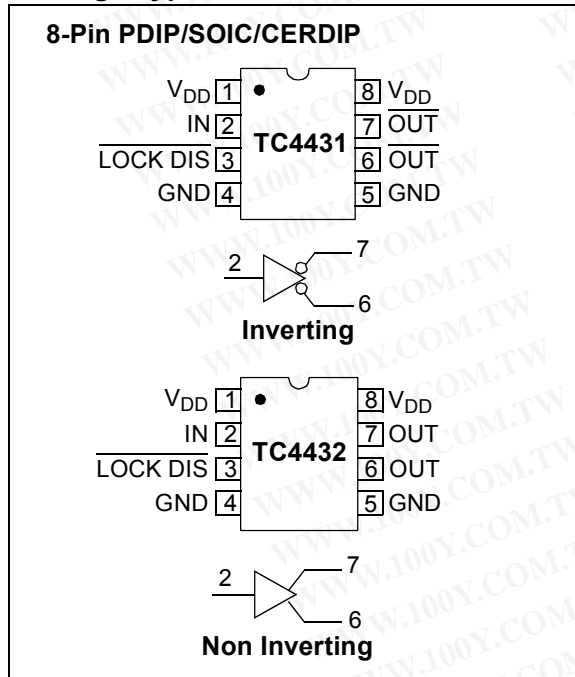

General Description

The TC4431/TC4432 are 30V CMOS buffer/drivers suitable for use in high-side driver applications. They will not latch-up under any conditions within their power and voltage ratings. They can accept, without damage or logic upset, up to 300 mA of reverse current (of either polarity) being forced back into their outputs. All terminals are fully protected against up to 4 kV of electrostatic discharge.

Undervoltage lockout circuitry forces the output to a 'low' state when the input supply voltage drops below 7V. For operation at lower voltages, disable the lockout and start-up circuit by grounding pin 3 (LOCK DIS); for all other situations, pin 3 should be left floating. The under-voltage lockout and start-up circuit gives brown-out protection when driving MOSFETS.

勝特力材料 886-3-5753170
 勝特力电子(上海) 86-21-34970699
 勝特力电子(深圳) 86-755-83298787
[Http://www.100y.com.tw](http://www.100y.com.tw)

TC4431/TC4432

Functional Block Diagram

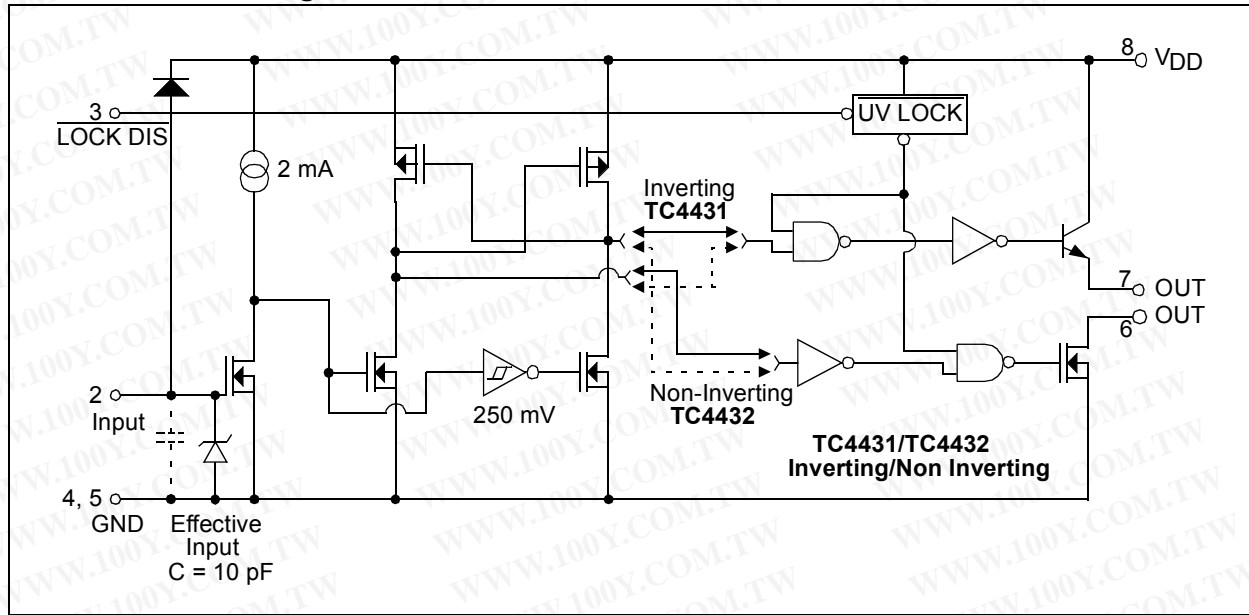

1.0 ELECTRICAL CHARACTERISTICS

Absolute Maximum Ratings†

Supply Voltage	36V
Input Voltage (Note 1).....	$V_{DD} + 0.3V$ to GND
Package Power Dissipation ($T_A \leq 70^\circ C$)	
PDIP	730 mW
CERDIP	800 mW
SOIC.....	470 mW
Maximum Junction Temperature, T_J	+150°C
Storage Temperature Range.....	-65°C to +150°C

† Stresses above those listed under "Absolute Maximum Ratings" may cause permanent damage to the device. These are stress ratings only and functional operation of the device at these or any other conditions above those indicated in the operation sections of the specifications is not implied. Exposure to Absolute Maximum Rating conditions for extended periods may affect device reliability.

DC CHARACTERISTICS

Electrical Specifications: Unless otherwise noted, $T_A = +25^\circ C$ with $4.5V \leq V_{DD} \leq 30V$.

Parameters	Sym	Min	Typ	Max	Units	Conditions
Input						
Logic '1', High Input Voltage	V_{IH}	2.4	—	—	V	
Logic '0', Low Input Voltage	V_{IL}	—	—	0.8	V	
Input Current (Note 1)	I_{IN}	-1	—	1	μA	$0V \leq V_{IN} \leq 12V$
Output						
High Output Voltage	V_{OH}	$V_{DD} - 1.0$	$V_{DD} - 0.8$	—	V	$I_{OUT} = 100$ mA
Low Output Voltage	V_{OL}	—	—	0.025	V	
Output Resistance	R_O	—	7	10	Ω	$I_{OUT} = 10$ mA, $V_{DD} = 30V$
Peak Output Current	I_{PK}	—	3.0	—	A	Source: $V_{DD} = 30V$ Sink: $V_{DD} = 30V$
Latch-Up Protection Withstand Reverse Current	I_{REV}	—	0.3	—	A	Duty cycle $\leq 2\%$, $t \leq 300$ μsec
Switching Time (Note 2)						
Rise Time	t_R	—	25	40	nsec	Figure 4-1
Fall Time	t_F	—	33	50	nsec	Figure 4-1
Delay Time	t_{D1}	—	62	80	nsec	Figure 4-1
Delay Time	t_{D2}	—	78	90	nsec	Figure 4-1
Power Supply						
Power Supply Current	I_S	—	2.5	4	mA	$V_{IN} = 3V$ $V_{IN} = 0V$
Start-up Threshold	V_S	—	8.4	10	V	
Drop-out Threshold	V_{DO}	7	7.7	—	V	Note 3

Note 1: For inputs $>12V$, add a 1 k Ω resistor in series with the input. See "Typical Characteristics" graph for input current.

2: Switching times are ensured by design.

3: For operation below 7V, pin 3 (LOCK DIS) should be tied to ground to disable the lockout and start-up circuit, otherwise, pin 3 **must** be left floating.

TC4431/TC4432

DC CHARACTERISTICS (Continued)

Electrical Specifications: Unless otherwise noted, Over operating temperature range with $4.5V \leq V_{DD} \leq 30V$.						
Parameters	Sym	Min	Typ	Max	Units	Conditions
Input						
Logic '1', High Input Voltage	V_{IH}	2.4	—	—	V	
Logic '0', Low Input Voltage	V_{IL}	—	—	0.8	V	
Input Current (Note 1)	I_{IN}	-10	—	10	μA	$0V \leq V_{IN} \leq 12V$
Output						
High Output Voltage	V_{OH}	$V_{DD} - 1.2$	—	—	V	$I_{OUT} = 100 \text{ mA}$
Low Output Voltage	V_{OL}	—	—	0.025	V	
Output Resistance	R_O	—	—	12	Ω	$I_{OUT} = 10 \text{ mA}, V_{DD} = 30V$
Switching Time (Note 2)						
Rise Time	t_R	—	—	60	nsec	Figure 4-1
Fall Time	t_F	—	—	70	nsec	Figure 4-1
Delay Time	t_{D1}	—	—	100	nsec	Figure 4-1
Delay Time	t_{D2}	—	—	110	nsec	Figure 4-1
Power Supply						
Power Supply Current	I_S	—	—	6 0.7	mA	$V_{IN} = 3V$ $V_{IN} = 0V$
Start-up Threshold	V_S	—	8.4	10	V	
Drop-out Threshold	V_{DO}	7	7.7	—	V	Note 3

Note 1: For inputs >12V, add a 1 k Ω resistor in series with the input. See "Typical Characteristics" graph for input current.

2: Switching times are ensured by design.

3: For operation below 7V, pin 3 (LOCK DIS) should be tied to ground to disable the lockout and start-up circuit, otherwise, pin 3 **must** be left floating.

TEMPERATURE CHARACTERISTICS

Electrical Specifications: Unless otherwise noted, all parameters apply with $4.5V \leq V_{DD} \leq 30V$.						
Parameters	Sym	Min	Typ	Max	Units	Conditions
Temperature Ranges						
Specified Temperature Range (C)	T_A	0	—	+70	$^{\circ}C$	
Specified Temperature Range (E)	T_A	-40	—	+85	$^{\circ}C$	
Maximum Junction Temperature	T_J	—	—	+150	$^{\circ}C$	
Storage Temperature Range	T_A	-65	—	+150	$^{\circ}C$	
Package Thermal Resistances						
Thermal Resistance, 8L-SOIC	θ_{JA}	—	155	—	$^{\circ}C/W$	
Thermal Resistance, 8L-PDIP	θ_{JA}	—	125	—	$^{\circ}C/W$	
Thermal Resistance, 8L-CERDIP	θ_{JA}	—	150	—	$^{\circ}C/W$	

2.0 TYPICAL PERFORMANCE CURVES

Note: The graphs and tables provided following this note are a statistical summary based on a limited number of samples and are provided for informational purposes only. The performance characteristics listed herein are not tested or guaranteed. In some graphs or tables, the data presented may be outside the specified operating range (e.g., outside specified power supply range) and therefore outside the warranted range.

Note: Unless otherwise indicated, $T_A = +25^\circ\text{C}$ with $4.5\text{V} \leq V_{DD} \leq 30\text{V}$.

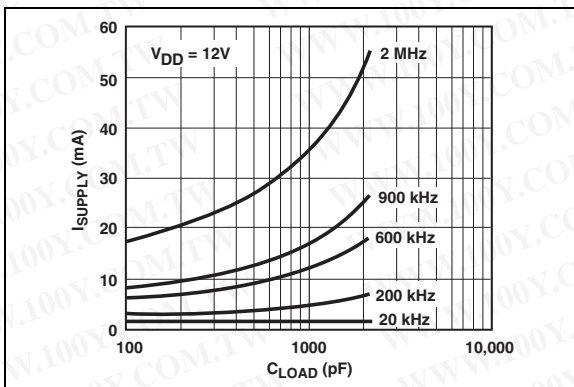

FIGURE 2-1: Supply Current vs. Capacitive Load.

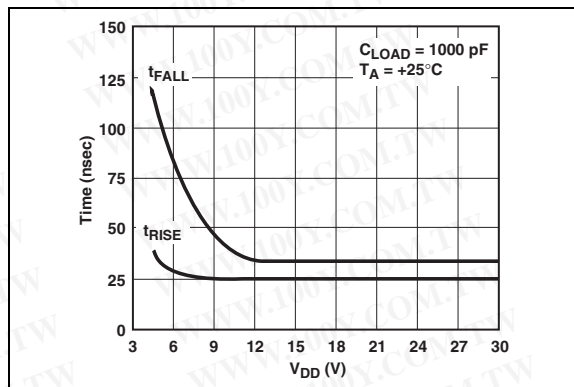

FIGURE 2-3: Rise/Fall Time vs. V_{DD} .

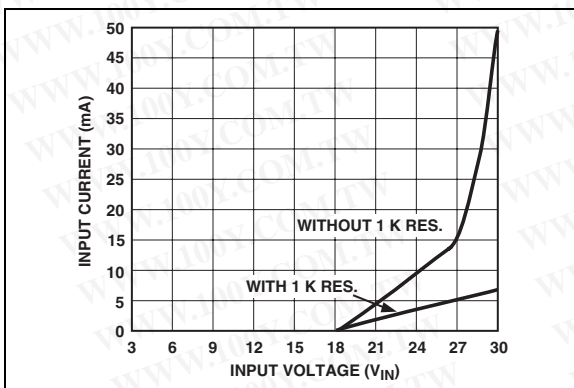

FIGURE 2-2: Input Current vs. Input Voltage.

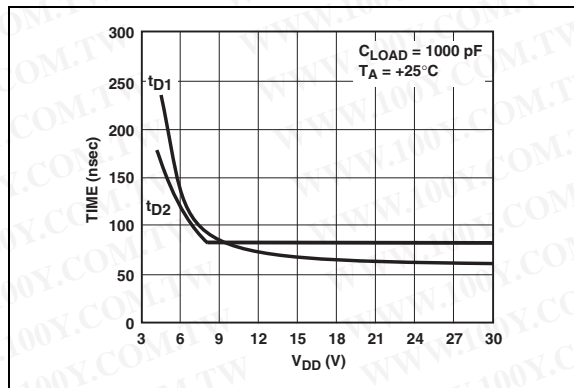

FIGURE 2-4: t_{D1} and t_{D2} Delay vs. V_{DD} .

TC4431/TC4432

3.0 PIN DESCRIPTIONS

The descriptions of the pins are listed in Table 3-1.

TABLE 3-1: PIN FUNCTION TABLE

Pin No.	Symbol	Description
1	V_{DD}	Supply Input, 4.5V to 30V
2	IN	TTL/CMOS Compatible Input
3	$\overline{\text{LOCK DIS}}$	Input Pin, Enable/Disable for UV Lockout
4	GND	Ground
5	GND	Ground
6	OUT	Drive Output, Pull Down
7	OUT	Drive Output, Pull Up
8	V_{DD}	Supply Input, 4.5V to 30V

3.1 Supply Input (V_{DD})

The V_{DD} input is the bias supply input for the MOSFET driver and is rated for 4.5V to 30V with respect to the ground pins. The V_{DD} input should be bypassed to ground with a local ceramic capacitor. The value of this capacitor should be chosen based on the capacitive load that is being driven.

3.2 Control Input (IN)

The MOSFET driver input is a TTL/CMOS compatible input with 250 mV of hysteresis between the high and low threshold voltages. If an input signal level of greater than 12V is applied to the device, a series current limiting resistor is recommended.

3.3 Lockout Disable ($\overline{\text{LOCK DIS}}$)

The lockout pin enables/disables the undervoltage lock-out feature of the device. If undervoltage lockout is desired (output is not enabled until the bias voltage reaches 8.4V (typical) on the rising edge and is disabled when the bias voltage reaches 7.7V (typical) on the falling edge), the lockout pin should be left floating. If operation below 7V is desired, the lockout pin should be tied to ground.

3.4 Ground (GND)

The ground pins are the return path for the bias current and for the high peak currents which discharge the load capacitor. Both ground pins should be used to ensure proper operation. The ground pins should be tied into a ground plane or have short traces to the bias supply source return.

3.5 Drive Output (OUT)

The TC4431/TC4432 devices have individual source and sink output pins. This feature can be used to adjust the rise and fall time independently by adding separate charge and discharge resistors external to the device. Pin 7 (source output) can source 3A peak currents into capacitive loads and pin 6 (sink output) can sink 1.5A peak currents from a capacitive load.

4.0 APPLICATIONS INFORMATION

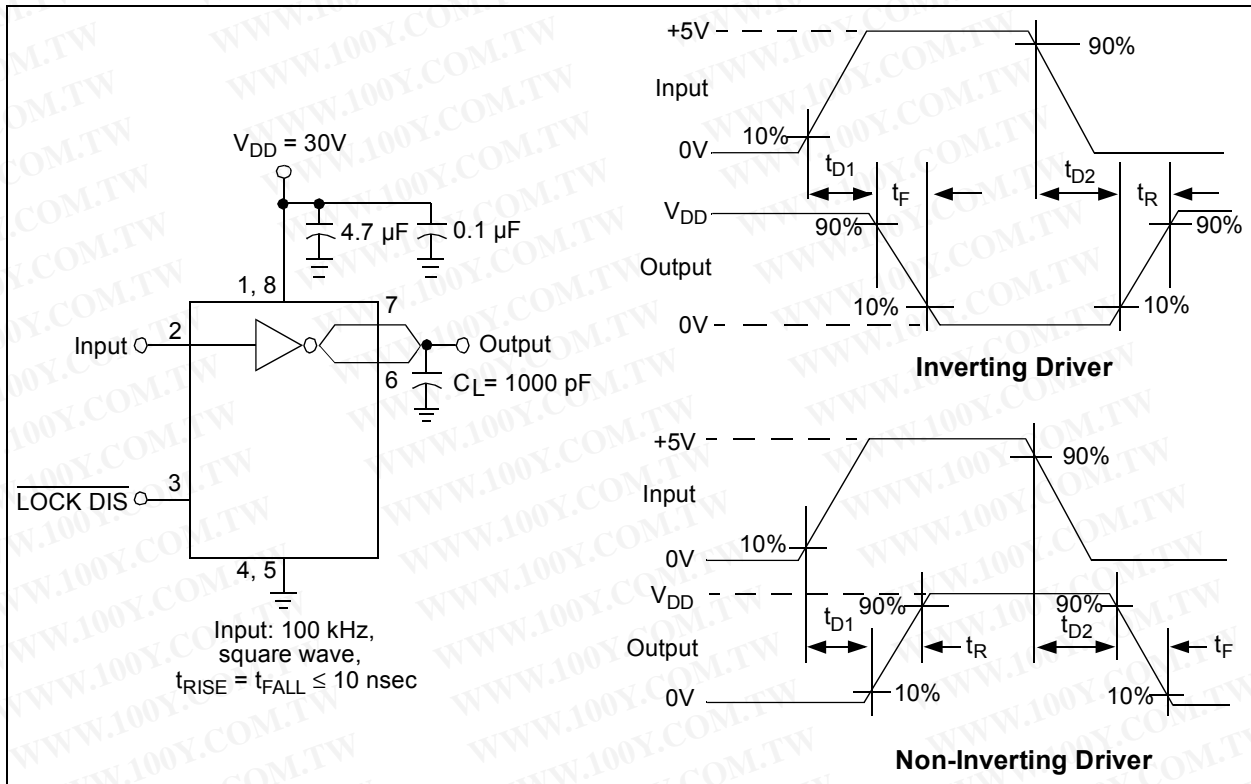

FIGURE 4-1: Switching Time Test Circuit.

TC4431/TC4432

5.0 PACKAGING INFORMATION

5.1 Package Marking Information

8-Lead PDIP (300 mil)

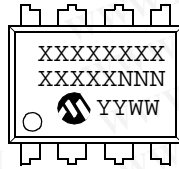

Example:

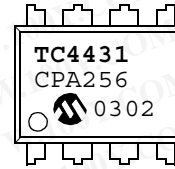

8-Lead SOIC (150 mil)

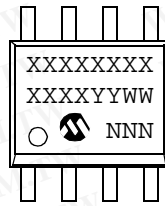

Example:

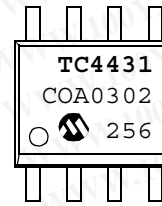

8-Lead CERDIP (300 mil)

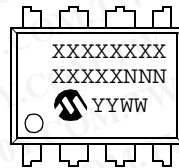

Example:

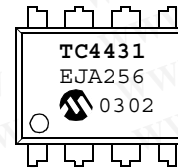

Legend:	XX...X	Customer specific information*
	YY	Year code (last 2 digits of calendar year)
	WW	Week code (week of January 1 is week '01')
	NNN	Alphanumeric traceability code

Note: In the event the full Microchip part number cannot be marked on one line, it will be carried over to the next line thus limiting the number of available characters for customer specific information.

* Standard OTP marking consists of Microchip part number, year code, week code, and traceability code.

TC4431/TC4432

8-Lead Plastic Dual In-line (P) – 300 mil (PDIP)

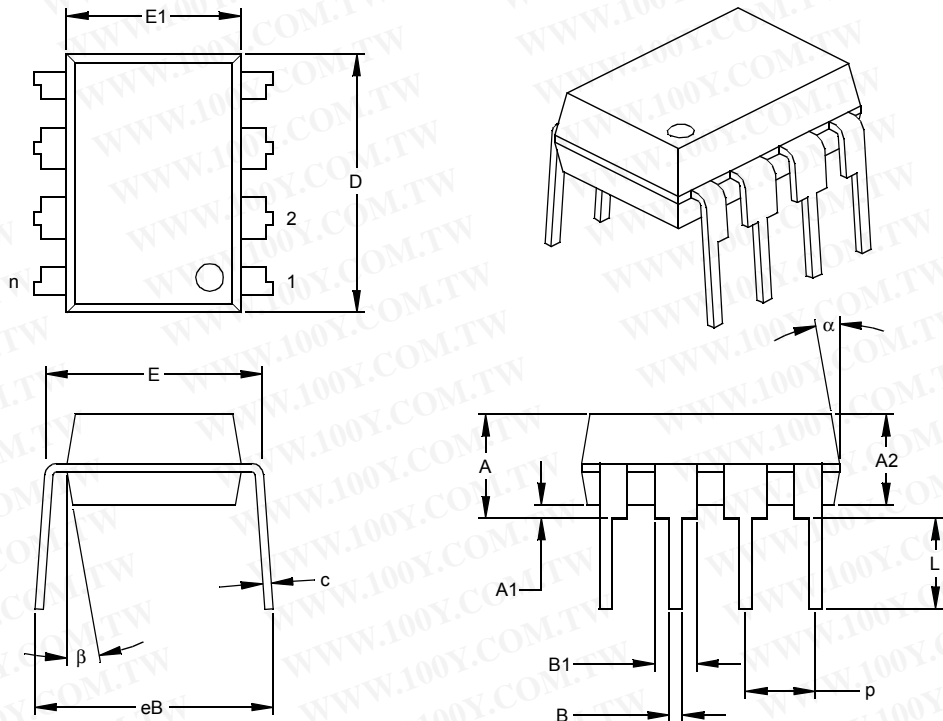

Dimension Limits	Units	INCHES*			MILLIMETERS		
		MIN	NOM	MAX	MIN	NOM	MAX
Number of Pins	n		8			8	
Pitch	p		.100			2.54	
Top to Seating Plane	A	.140	.155	.170	3.56	3.94	4.32
Molded Package Thickness	A2	.115	.130	.145	2.92	3.30	3.68
Base to Seating Plane	A1	.015			0.38		
Shoulder to Shoulder Width	E	.300	.313	.325	7.62	7.94	8.26
Molded Package Width	E1	.240	.250	.260	6.10	6.35	6.60
Overall Length	D	.360	.373	.385	9.14	9.46	9.78
Tip to Seating Plane	L	.125	.130	.135	3.18	3.30	3.43
Lead Thickness	c	.008	.012	.015	0.20	0.29	0.38
Upper Lead Width	B1	.045	.058	.070	1.14	1.46	1.78
Lower Lead Width	B	.014	.018	.022	0.36	0.46	0.56
Overall Row Spacing	§ eB	.310	.370	.430	7.87	9.40	10.92
Mold Draft Angle Top	α	5	10	15	5	10	15
Mold Draft Angle Bottom	β	5	10	15	5	10	15

* Controlling Parameter
 § Significant Characteristic

Notes:
 Dimensions D and E1 do not include mold flash or protrusions. Mold flash or protrusions shall not exceed .010" (0.254mm) per side.
 JEDEC Equivalent: MS-001
 Drawing No. C04-018

TC4431/TC4432

8-Lead Ceramic Dual In-line (JA) – 300 mil (CERDIP)

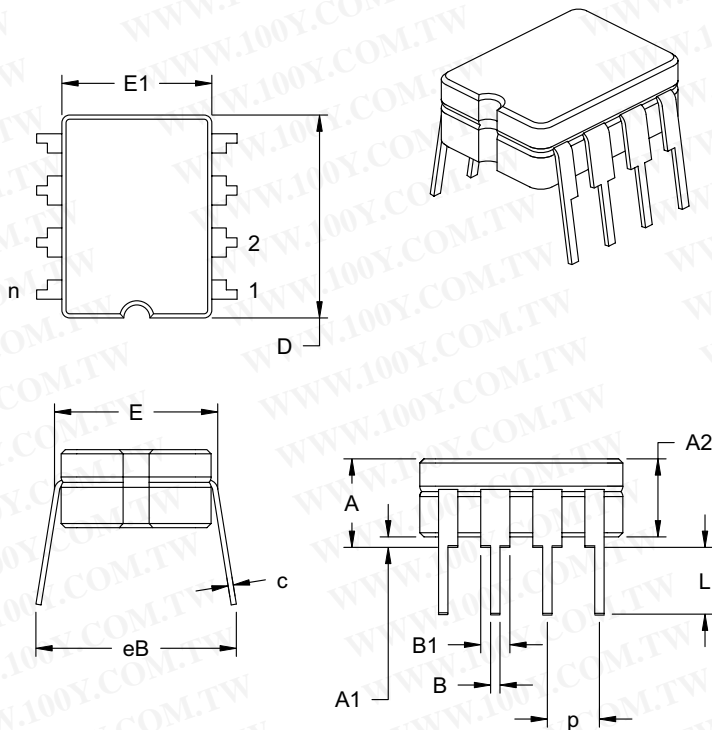

Dimension	Units Limits	INCHES*			MILLIMETERS		
		MIN	NOM	MAX	MIN	NOM	MAX
Number of Pins	n		8			8	
Pitch	p		.100			2.54	
Top to Seating Plane	A	.160	.180	.200	4.06	4.57	5.08
Standoff §	A1	.020	.030	.040	0.51	0.77	1.02
Shoulder to Shoulder Width	E	.290	.305	.320	7.37	7.75	8.13
Ceramic Pkg. Width	E1	.230	.265	.300	5.84	6.73	7.62
Overall Length	D	.370	.385	.400	9.40	9.78	10.16
Tip to Seating Plane	L	.125	.163	.200	3.18	4.13	5.08
Lead Thickness	c	.008	.012	.015	0.20	0.29	0.38
Upper Lead Width	B1	.045	.055	.065	1.14	1.40	1.65
Lower Lead Width	B	.016	.018	.020	0.41	0.46	0.51
Overall Row Spacing	eB	.320	.360	.400	8.13	9.15	10.16

*Controlling Parameter

JEDEC Equivalent: MS-030

Drawing No. C04-010

TC4431/TC4432

8-Lead Plastic Small Outline (SN) – Narrow, 150 mil (SOIC)

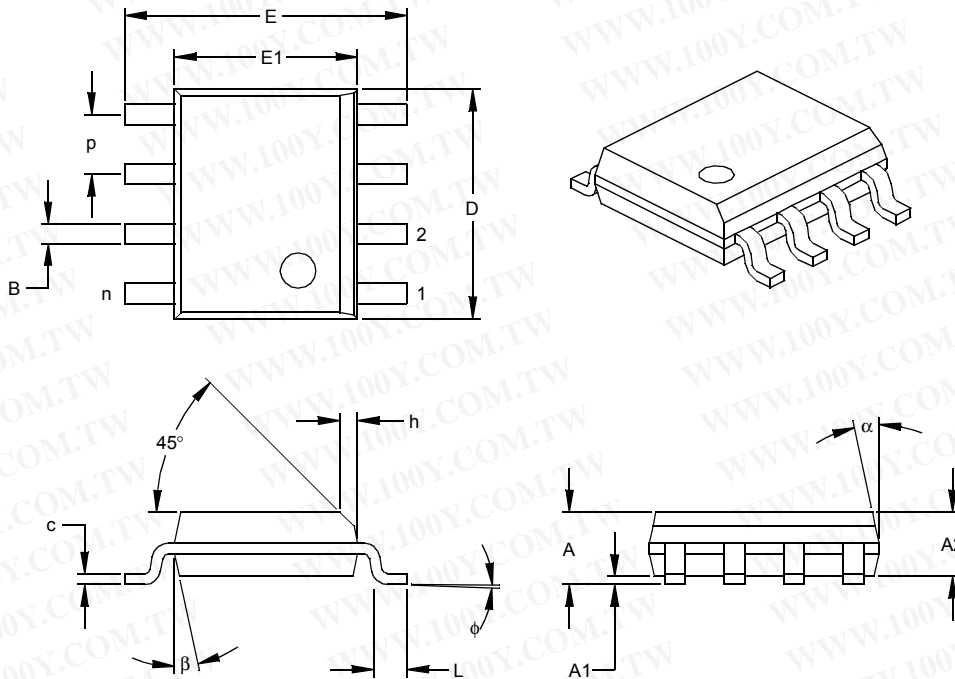

Units		INCHES*			MILLIMETERS		
Dimension	Limits	MIN	NOM	MAX	MIN	NOM	MAX
Number of Pins	n		8			8	
Pitch	p		.050			1.27	
Overall Height	A	.053	.061	.069	1.35	1.55	1.75
Molded Package Thickness	A2	.052	.056	.061	1.32	1.42	1.55
Standoff §	A1	.004	.007	.010	0.10	0.18	0.25
Overall Width	E	.228	.237	.244	5.79	6.02	6.20
Molded Package Width	E1	.146	.154	.157	3.71	3.91	3.99
Overall Length	D	.189	.193	.197	4.80	4.90	5.00
Chamfer Distance	h	.010	.015	.020	0.25	0.38	0.51
Foot Length	L	.019	.025	.030	0.48	0.62	0.76
Foot Angle	ϕ	0	4	8	0	4	8
Lead Thickness	c	.008	.009	.010	0.20	0.23	0.25
Lead Width	B	.013	.017	.020	0.33	0.42	0.51
Mold Draft Angle Top	α	0	12	15	0	12	15
Mold Draft Angle Bottom	β	0	12	15	0	12	15

* Controlling Parameter
 § Significant Characteristic

Notes:

Dimensions D and E1 do not include mold flash or protrusions. Mold flash or protrusions shall not exceed .010" (0.254mm) per side.

JEDEC Equivalent: MS-012

Drawing No. C04-057

TC4431/TC4432

NOTES:

PRODUCT IDENTIFICATION SYSTEM

To order or obtain information, e.g., on pricing or delivery, refer to the factory or the listed sales office.

<u>PART NO.</u>	<u>X</u>	<u>/XX</u>	Examples:
Device	Temperature Range	Package	
Device:	TC4431:	1.5A High-Speed 30V MOSFET Driver, Inverting	a) TC4431COA: 1.5A MOSFET driver, SOIC package, 0°C to +70°C.
	TC4432:	1.5A High-Speed 30V MOSFET Driver, Non Inverting	b) TC4431EJA: 1.5A MOSFET driver, CERDIP package, -40°C to +85°C.
Temperature Range:	C =	0°C to +70°C	a) TC4432CPA: 1.5A MOSFET driver, PDIP package, 0°C to +70°C.
	E =	-40°C to +85°C	b) TC4432EPA: 1.5A MOSFET driver, PDIP package, -40°C to +85°C.
Package:	JA =	Ceramic Dual In-line (300 mil Body), 8-lead *	
	OA =	Plastic SOIC, (150 mil Body), 8-lead	
	OA713 =	Plastic SOIC, (150 mil Body), 8-lead (Tape and Reel)	
	PA =	Plastic DIP (300 mil Body), 8-lead	
	* Offered in E-temp range only.		

Sales and Support

Data Sheets

Products supported by a preliminary Data Sheet may have an errata sheet describing minor operational differences and recommended workarounds. To determine if an errata sheet exists for a particular device, please contact one of the following:

1. Your local Microchip sales office
2. The Microchip Corporate Literature Center U.S. FAX: (480) 792-7277
3. The Microchip Worldwide Site (www.microchip.com)

Please specify which device, revision of silicon and Data Sheet (include Literature #) you are using.

Customer Notification System

Register on our web site (www.microchip.com/cn) to receive the most current information on our products.

TC4431/TC4432

NOTES:

Note the following details of the code protection feature on Microchip devices:

- Microchip products meet the specification contained in their particular Microchip Data Sheet.
- Microchip believes that its family of products is one of the most secure families of its kind on the market today, when used in the intended manner and under normal conditions.
- There are dishonest and possibly illegal methods used to breach the code protection feature. All of these methods, to our knowledge, require using the Microchip products in a manner outside the operating specifications contained in Microchip's Data Sheets. Most likely, the person doing so is engaged in theft of intellectual property.
- Microchip is willing to work with the customer who is concerned about the integrity of their code.
- Neither Microchip nor any other semiconductor manufacturer can guarantee the security of their code. Code protection does not mean that we are guaranteeing the product as "unbreakable."

Code protection is constantly evolving. We at Microchip are committed to continuously improving the code protection features of our products. Attempts to break microchip's code protection feature may be a violation of the Digital Millennium Copyright Act. If such acts allow unauthorized access to your software or other copyrighted work, you may have a right to sue for relief under that Act.

Information contained in this publication regarding device applications and the like is intended through suggestion only and may be superseded by updates. It is your responsibility to ensure that your application meets with your specifications. No representation or warranty is given and no liability is assumed by Microchip Technology Incorporated with respect to the accuracy or use of such information, or infringement of patents or other intellectual property rights arising from such use or otherwise. Use of Microchip's products as critical components in life support systems is not authorized except with express written approval by Microchip. No licenses are conveyed, implicitly or otherwise, under any intellectual property rights.

勝特力材料 886-3-5753170
勝特力电子(上海) 86-21-34970699
勝特力电子(深圳) 86-755-83298787
[Http://www.100y.com.tw](http://www.100y.com.tw)

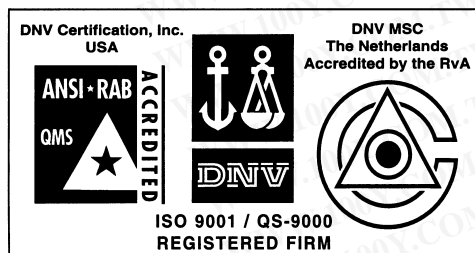

Trademarks

The Microchip name and logo, the Microchip logo, KEELOQ, MPLAB, PIC, PICmicro, PICSTART, PRO MATE and PowerSmart are registered trademarks of Microchip Technology Incorporated in the U.S.A. and other countries.

FilterLab, microID, MXDEV, MXLAB, PICMASTER, SEEVAL and The Embedded Control Solutions Company are registered trademarks of Microchip Technology Incorporated in the U.S.A.

Accuron, Application Maestro, dsPIC, dsPICDEM, dsPICDEM.net, ECONOMONITOR, FanSense, FlexROM, fuzzyLAB, In-Circuit Serial Programming, ICSP, ICEPIC, microPort, Migratable Memory, MPASM, MPLIB, MPLINK, MPSIM, PICC, PICkit, PICDEM, PICDEM.net, PowerCal, PowerInfo, PowerMate, PowerTool, rLAB, rPIC, Select Mode, SmartSensor, SmartShunt, SmartTel and Total Endurance are trademarks of Microchip Technology Incorporated in the U.S.A. and other countries.

Serialized Quick Turn Programming (SQTP) is a service mark of Microchip Technology Incorporated in the U.S.A.

All other trademarks mentioned herein are property of their respective companies.

© 2003, Microchip Technology Incorporated, Printed in the U.S.A., All Rights Reserved.

Printed on recycled paper.

Microchip received QS-9000 quality system certification for its worldwide headquarters, design and wafer fabrication facilities in Chandler and Tempe, Arizona in July 1999 and Mountain View, California in March 2002. The Company's quality system processes and procedures are QS-9000 compliant for its PICmicro® 8-bit MCUs, KEELOQ® code hopping devices, Serial EEPROMs, microperipherals, non-volatile memory and analog products. In addition, Microchip's quality system for the design and manufacture of development systems is ISO 9001 certified.