

IRS20957S Protected Digital Audio Driver

Features

- Floating PWM input enables easy half bridge implementation
- Programmable bidirectional over-current protection with self-reset function
- Programmable preset dead-time for improved THD performances
- High noise immunity
- $\pm 100V$ ratings deliver up to 500W in output power
- 3.3 V/ 5 V logic compatible input
- Operates up to 800kHz

Typical Applications

- Home theatre systems
- Mini component stereo systems
- Powered speaker systems
- General purpose audio power amplifiers

勝特力材料 886-3-5753170
 勝特力电子(上海) 86-21-34970699
 勝特力电子(深圳) 86-755-83298787
[Http://www.100y.com.tw](http://www.100y.com.tw)

Product Summary

Topology	Half-Bridge
$V_{\text{OFFSET (max)}}$	+/- 100 V
$I_{\text{O+}} & I_{\text{O-}}$ (typical)	1.0 A & 1.2 A
Selectable deadtime	15/25/35/80ns
Ton & toff (typical)	95ns & 80ns
OC protection delay	500ns (max)
Shutdown propagation delay	250ns (max)

Package



Typical Connection Diagram

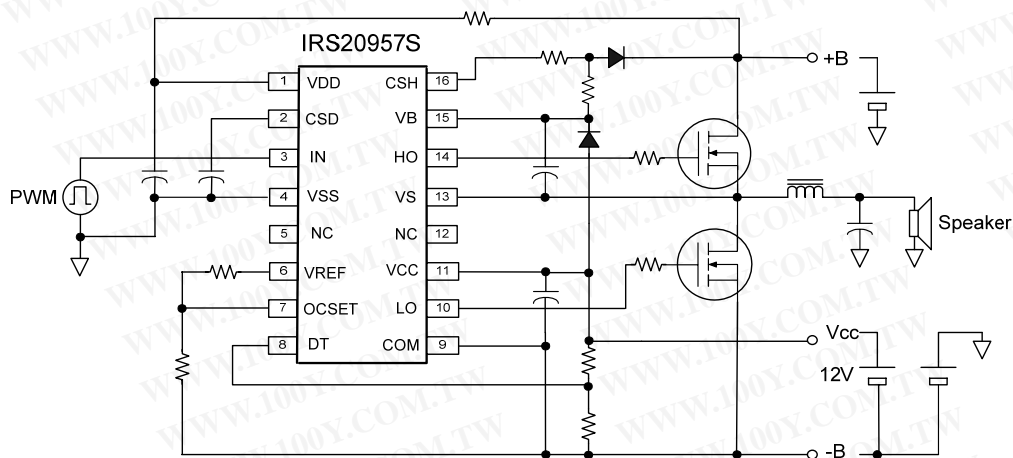

Note: Please refer to Lead Assignments for correct pin configuration. This diagram shows electrical connections only.

Table of Contents	Page
Description	3
Qualification Information	4
Absolute Maximum Ratings	5
Recommended Operating Conditions	6
Electrical Characteristics	7
Functional Block Diagram	9
Input/Output Pin Equivalent Circuit Diagram	10
Lead Definitions	11
Lead Assignments	11
Waveform definitions	12
Application information and additional information	12
Package Details	13
Tape and Reel Details	14
Part Marking Information	15
Ordering Information	16

Description

The IRS20957S is a high voltage, high speed MOSFET driver with a floating PWM input designed for Class D audio amplifier applications.

Bi-directional current sensing detects over current conditions during positive and negative load currents without any external shunt resistors. A built-in protection control block provides a secure protection sequence against over-current conditions and a programmable reset timer.

The internal dead-time generation block enables accurate gate switching and optimum dead-time setting for better audio performance, such as lower THD and lower audio noise floor.

Qualification Information[†]

Qualification Level		Industrial ^{††}	
		Comments: This family of ICs has passed JEDEC's Industrial qualification. IR's Consumer qualification level is granted by extension of the higher Industrial level.	
Moisture Sensitivity Level		SOIC16N	MSL2 ^{†††} 260°C (per IPC/JEDEC J-STD-020)
ESD	Machine Model	Class B (per JEDEC standard EIA/JESD22-A115)	
	Human Body Model	Class 2 (per EIA/JEDEC standard JESD22-A114)	
IC Latch-Up Test		Class I, Level A (per JESD78)	
RoHS Compliant		Yes	

† Qualification standards can be found at International Rectifier's web site <http://www.irf.com/>

†† Higher qualification ratings may be available should the user have such requirements. Please contact your International Rectifier sales representative for further information.

††† Higher MSL ratings may be available for the specific package types listed here. Please contact your International Rectifier sales representative for further information.

Absolute Maximum Ratings

Absolute Maximum Ratings indicate sustained limits beyond which damage to the device may occur. All voltage parameters are absolute voltages referenced to V_{SS} ; all currents are defined positive into any lead. The Thermal Resistance and Power Dissipation ratings are measured under board mounted and still air conditions.

Symbol	Definition	Min.	Max.	Units
V_B	High side floating supply voltage	-0.3	215	V
V_S	High side floating supply voltage [†]	V_B-15	$V_B+0.3$	
V_{HO}	High side floating output voltage	$V_S-0.3$	$V_B+0.3$	
V_{CSH}	CSH pin input voltage	$V_S-0.3$	$V_B+0.3$	
V_{CC}	Low side fixed supply voltage [†]	-0.3	20	
V_{LO}	Low side output voltage	-0.3	$V_{CC} +0.3$	
V_{DD}	Floating input supply voltage	-0.3	210	
V_{SS}	Floating input supply voltage [†]	(See I_{DDZ})	$V_{DD}+0.3$	
V_{IN}	PWM input voltage	$V_{SS} -0.3$	$V_{DD}+0.3$	
V_{CSD}	CSD pin input voltage	$V_{SS} -0.3$	$V_{DD}+0.3$	
V_{DT}	DT pin input voltage	-0.3	$V_{CC} +0.3$	
V_{OCSET}	OCSET pin input voltage	-0.3	$V_{CC} +0.3$	
V_{REF}	VREF pin voltage	-0.3	$V_{CC} +0.3$	
I_{DDZ}	Floating input supply zener clamp current [†]	-	10	
I_{CCZ}	Low side supply zener clamp current [†]	-	10	
I_{BSZ}	Floating supply zener clamp current [†]	-	10	
I_{OREF}	Reference output current	-	5	
$d V_S /dt$	Allowable V_S voltage slew rate	-	50	V/ns
$d V_{SS} /dt$	Allowable V_{SS} voltage slew rate ^{††}	-	50	
$d V_{SS} /dt$	Allowable V_{SS} voltage slew rate upon power-up ^{†††}	-	50	V/ms
P_d	Maximum power dissipation	-	1.0	W
R_{thJA}	Thermal resistance, Junction to ambient	-	115	°C/W
T_J	Junction Temperature	-	150	°C
T_S	Storage Temperature	-55	150	
T_L	Lead temperature (Soldering, 10 seconds)	-	300	

† $V_{DD} - V_{SS}$, $V_{CC} -COM$ and $V_B - V_S$ contain internal shunt zener diodes. Please note that the voltage ratings of these can be limited by the clamping current.

†† For the rising and falling edges of step signal of 10V. $V_{SS}=15V$ to 200V.

††† V_{SS} ramps up from 0V to 200V.

Recommended Operating Conditions

For proper operation, the device should be used within the recommended conditions below. The V_S and COM offset ratings are tested with supplies biased at $I_{DD}=5\text{mA}$, $V_{CC}=12\text{V}$ and $V_B-V_S=12\text{V}$.

Symbol	Definition	Min.	Max.	Units
V_B	High side floating supply absolute voltage	V_S+10	V_S+14	V
V_S	High side floating supply offset voltage	†	200	
I_{DDZ}	Floating input supply zener clamp current	1	5	mA
V_{SS}	Floating input supply absolute voltage	0	100	V
V_{HO}	High side floating output voltage	V_S	V_B	
V_{CC}	Low side fixed supply voltage	10	15	
V_{LO}	Low side output voltage	0	V_{CC}	
V_{IN}	PWM input voltage	V_{SS}	V_{DD}	
V_{CSD}	CSD pin input voltage	V_{SS}	V_{DD}	
V_{DT}	DT pin input voltage	0	V_{CC}	
I_{OREF}	Reference output current to COM†	0.3	0.8	mA
V_{OCSET}	OCSET pin input voltage	0.5	5	V
T_A	Ambient Temperature	-40	125	°C

† Logic operational for V_S equal to -5V to $+200\text{V}$. Logic state held for V_S equal to -5V to $-V_{BS}$.

†† Nominal voltage for V_{REF} is 5V. I_{OREF} of 0.3 – 0.8mA dictates total external resistor value on V_{REF} to be 6.3k to 16.7k Ω .

Electrical Characteristics

$V_{CC}, V_{BS} = 12\text{ V}$, $I_{DD} = 5\text{ mA}$, $V_{SS} = 20\text{ V}$, $V_S = 0\text{ V}$, $C_L = 1\text{ nF}$ and $T_A = 25^\circ\text{C}$ unless otherwise specified.

Symbol	Description	Min	Typ	Max	Units	Test Conditions
Low Side Supply						
UV_{CC+}	V_{CC} supply UVLO positive threshold	8.4	8.9	9.4	V	
UV_{CC-}	V_{CC} supply UVLO negative threshold	8.2	8.7	9.2		
I_{QCC}	Low side quiescent current	-	-	3	mA	$V_{DT} = V_{CC}$
V_{CLAMPL}	Low side zener diode clamp voltage	19.6	20.4	21.6	V	$I_{CC} = 5\text{ mA}$
High Side Floating Supply						
UV_{BS+}	High side well UVLO positive threshold	8.0	8.5	9.0	V	
UV_{BS-}	High side well UVLO negative threshold	7.8	8.3	8.8		
I_{QBS}	High side quiescent current	-	-	1	mA	
I_{LKH}	High to Low side leakage current	-	-	50	μA	$V_B = V_S = 200\text{ V}$
V_{CLAMPH}	High side zener diode clamp voltage	14.7	15.3	16.2	V	$I_{BS} = 5\text{ mA}$
Floating Input Supply						
UV_{DD+}	V_{DD}, V_{SS} floating supply UVLO positive threshold	8.2	8.7	9.2	V	$V_{SS} = 0\text{ V}$
UV_{DD-}	V_{DD}, V_{SS} floating supply UVLO negative threshold	7.7	8.2	8.7		$V_{SS} = 0\text{ V}$
I_{QDD}	Floating Input quiescent current	-	-	1	mA	$V_{DD} = 9.5\text{ V} + V_{SS}$
V_{CLAMPM}	Floating Input zener diode clamp voltage	9.8	10.2	10.8	V	$I_{DD} = 5\text{ mA}$
I_{LKM}	Floating input side to Low side leakage current	-	-	50	μA	$V_{DD} = V_{SS} = 200\text{ V}$
Floating PWM Input						
V_{IH}	Logic high input threshold voltage	2.3	1.9	-	V	
V_{IL}	Logic low input threshold voltage	-	1.9	1.5		
I_{IN+}	Logic "1" input bias current	-	-	40	μA	$V_{IN} = 3.3\text{ V}$
I_{IN-}	Logic "0" input bias current	-	-	1		$V_{IN} = V_{SS}$
Protection						
V_{REF}	Reference output voltage	4.8	5.1	5.4	V	$I_{OREF} = 0.5\text{ mA}$
V_{thOCL}	Low side OC threshold in V_S	1.1	1.2	1.3		OCSET=1.2V, Figure 3
V_{thOCH}	High side OC threshold in V_{CSH}	$1.1 + V_S$	$1.2 + V_S$	$1.3 + V_S$		$V_S = 200\text{ V}$, Figure 4
V_{th1}	CSD pin shutdown release threshold	$0.62 \times V_{DD}$	$0.70 \times V_{DD}$	$0.78 \times V_{DD}$		$V_{SS} = 0\text{ V}$
V_{th2}	CSD pin self reset threshold	$0.26 \times V_{DD}$	$0.30 \times V_{DD}$	$0.34 \times V_{DD}$		$V_{SS} = 0\text{ V}$
I_{CSD+}	CSD pin discharge current	70	100	130	μA	$V_{SD} = V_{SS} + 5\text{ V}$
I_{CSD-}	CSD pin charge current	70	100	130		$V_{SD} = V_{SS} + 5\text{ V}$

Protection (continued)							
Symbol	Description	Min	Typ	Max	Units	Test Conditions	
t_{SD}	Shutdown propagation delay from $V_{CSD} > V_{SS} + V_{th_{OCH}}$ to Shutdown	-	-	250	ns	Figure 2	
t_{OCH}	Propagation delay time from $V_{CSH} > V_{th_{OCH}}$ to Shutdown	-	-	500		Figure 4	
t_{OCL}	Propagation delay time from $V_S > V_{th_{OCL}}$ to Shutdown	-	-	500		Figure 3	
Gate Driver							
I_{o+}	Output high short circuit current (Source)	-	1.0	-	A	$V_o=0V$, $PW \leq 10\mu S$	
I_{o-}	Output low short circuit current (Sink)	-	1.2	-		$V_o=12V$, $PW \leq 10\mu S$	
V_{OL}	Low level out put voltage LO – COM, HO – VS	-	-	0.1	V	$I_o=0A$	
V_{OH}	High level out put voltage VCC – LO, VB – HO	-	-	1.4		$I_o=0A$	
t_r	Turn-on rise time	-	15	-	ns		
t_f	Turn-off fall time	-	10	-			
Ton_1	High and low side turn-on propagation delay, floating inputs	-	95	-		$V_{DT} = V_{CC}$, $V_S = 100V$, $V_{SS} = 100V$	
Toff_1	High and low side turn-off propagation delay, floating inputs	-	80	-		$V_{DT} = V_{CC}$, $V_S = 100V$, $V_{SS} = 100V$	
Ton_2	High and low side turn-on propagation delay, non-floating inputs	-	95	-		$V_{DT} = V_{CC}$, $V_S = 100V$, $V_{SS} = COM$	
Toff_2	High and low side turn-off propagation delay, non-floating inputs	-	80	-		$V_{DT} = V_{CC}$, $V_S = 100V$, $V_{SS} = COM$	
DT1	Deadtime: LO turn-off to HO turn-on (DT_{LO-HO}) & HO turn-off to LO turn-on (DT_{HO-LO})	8	15	22		$V_{DT} > V_{DT1}$, $V_{SS} = COM$	
DT2	Deadtime: LO turn-off to HO turn-on (DT_{LO-HO}) & HO turn-off to LO turn-on (DT_{HO-LO})	15	25	35		$V_{DT1} > V_{DT} > V_{DT2}$, $V_{SS} = COM$	
DT3	Deadtime: LO turn-off to HO turn-on (DT_{LO-HO}) & HO turn-off to LO turn-on (DT_{HO-LO})	20	35	50		$V_{DT2} > V_{DT} > V_{DT3}$, $V_{SS} = COM$	
DT4	Deadtime: LO turn-off to HO turn-on (DT_{LO-HO}) & HO turn-off to LO turn-on (DT_{HO-LO}) $V_{DT} = V_{DT4}$	50	80	110		$V_{DT3} > V_{DT}$, $V_{SS} = COM$	
V_{DT1}	DT mode select threshold 1	$0.51 \times V_{CC}$	$0.57 \times V_{CC}$	$0.63 \times V_{CC}$		V	
V_{DT2}	DT mode select threshold 2	$0.32 \times V_{CC}$	$0.36 \times V_{CC}$	$0.40 \times V_{CC}$			
V_{DT3}	DT mode select threshold 3	$0.21 \times V_{CC}$	$0.23 \times V_{CC}$	$0.25 \times V_{CC}$			

Functional Block Diagram

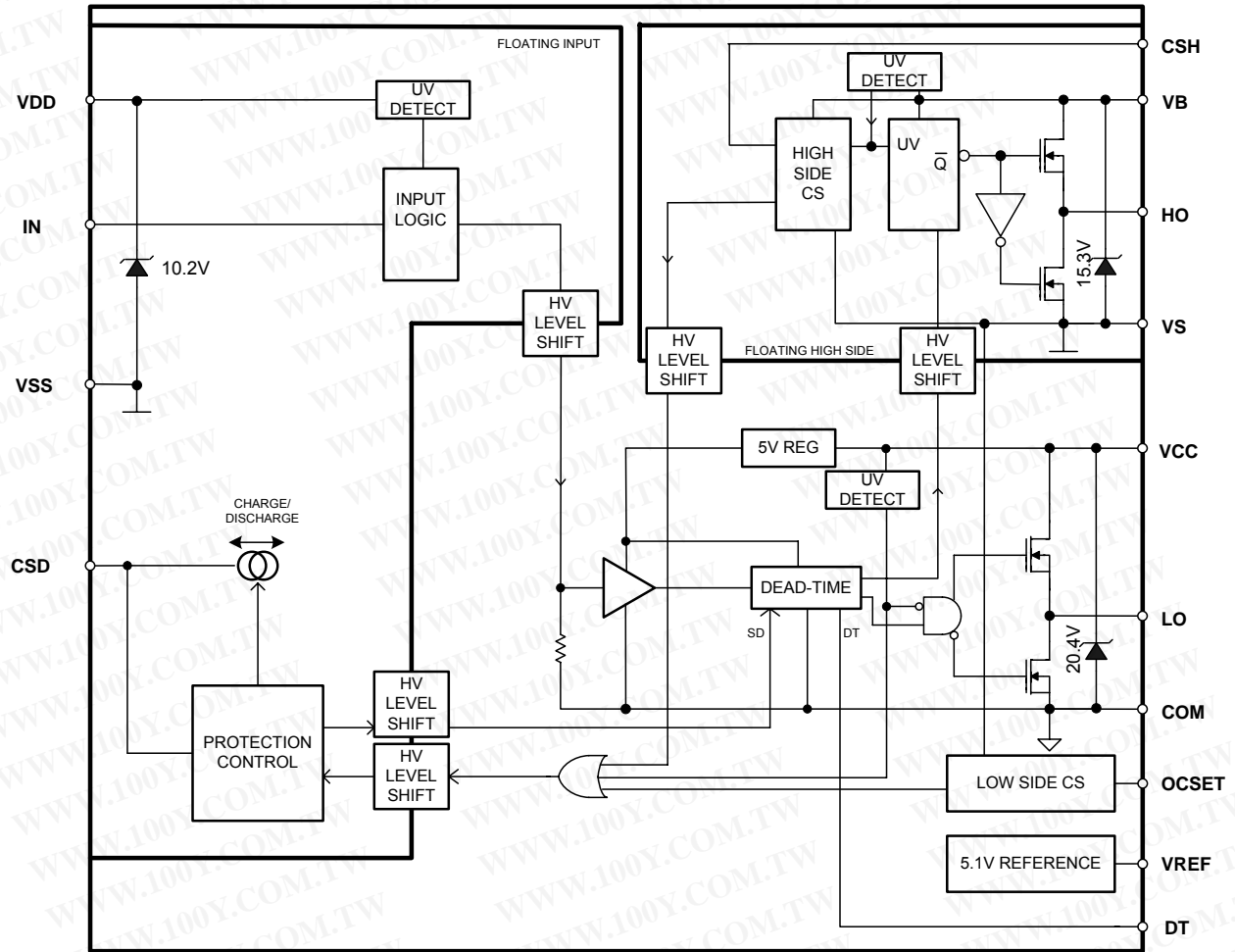

I/O Pin Equivalent Circuit Diagrams

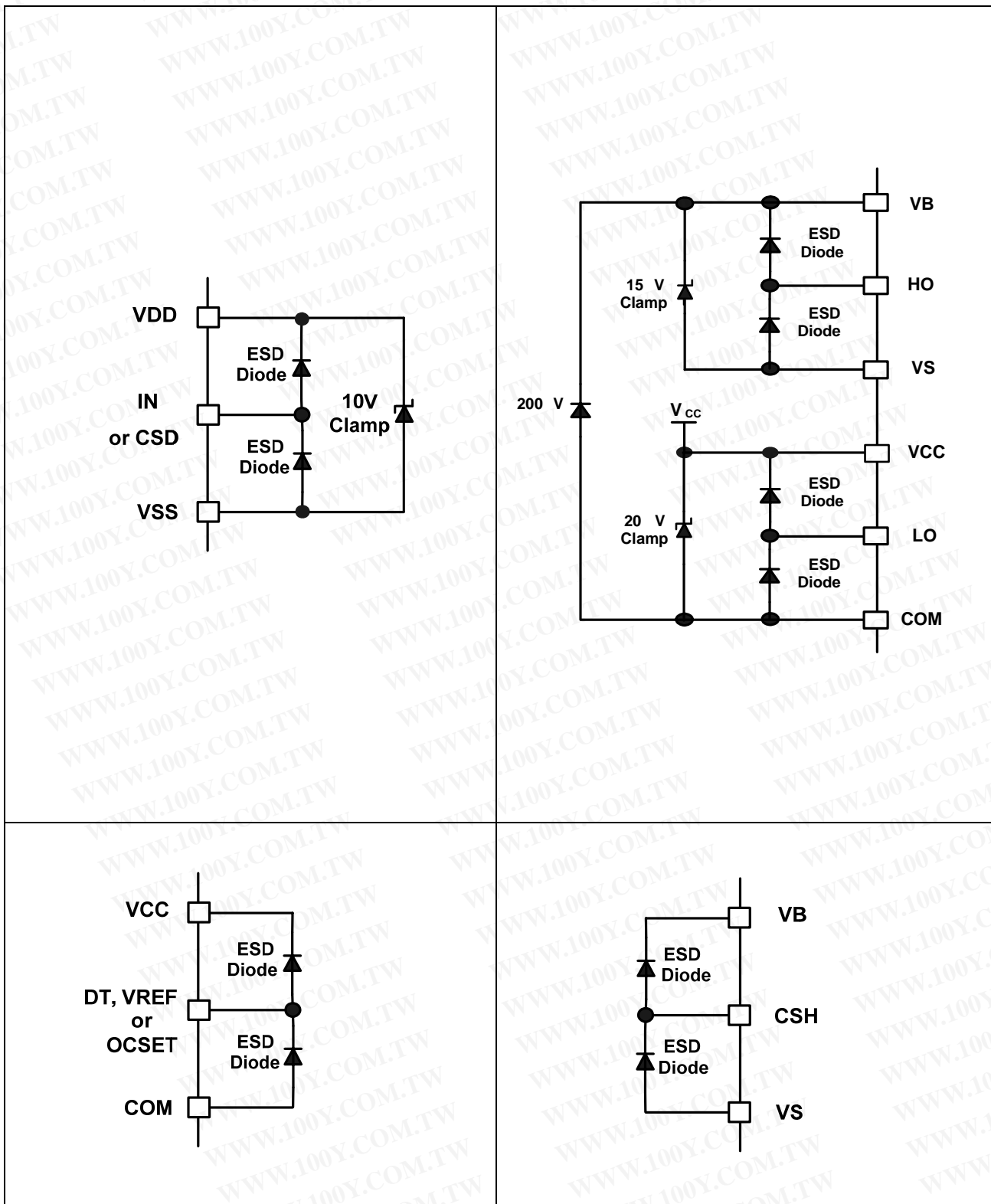

Waveform definitions

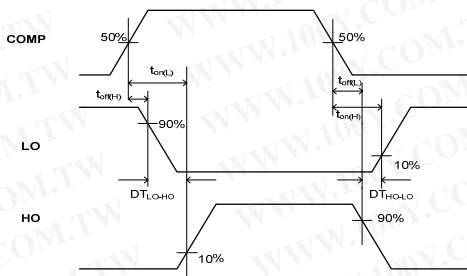

Figure 1: Switching Time Waveform Definitions

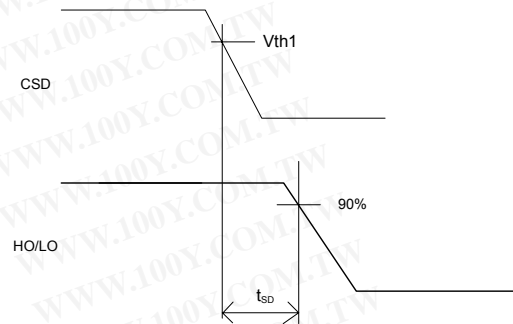

Figure 2: CSD to Shutdown Waveform Definitions

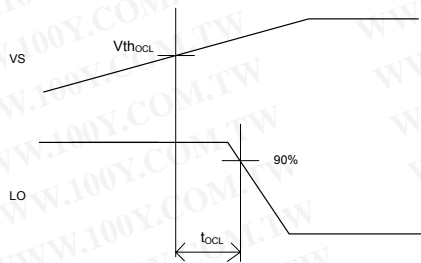

Figure 3: $V_s > V_{th_{oCL}}$ to Shutdown Waveform

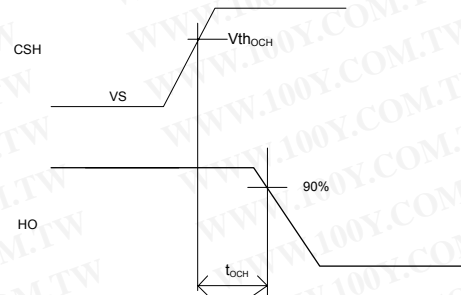
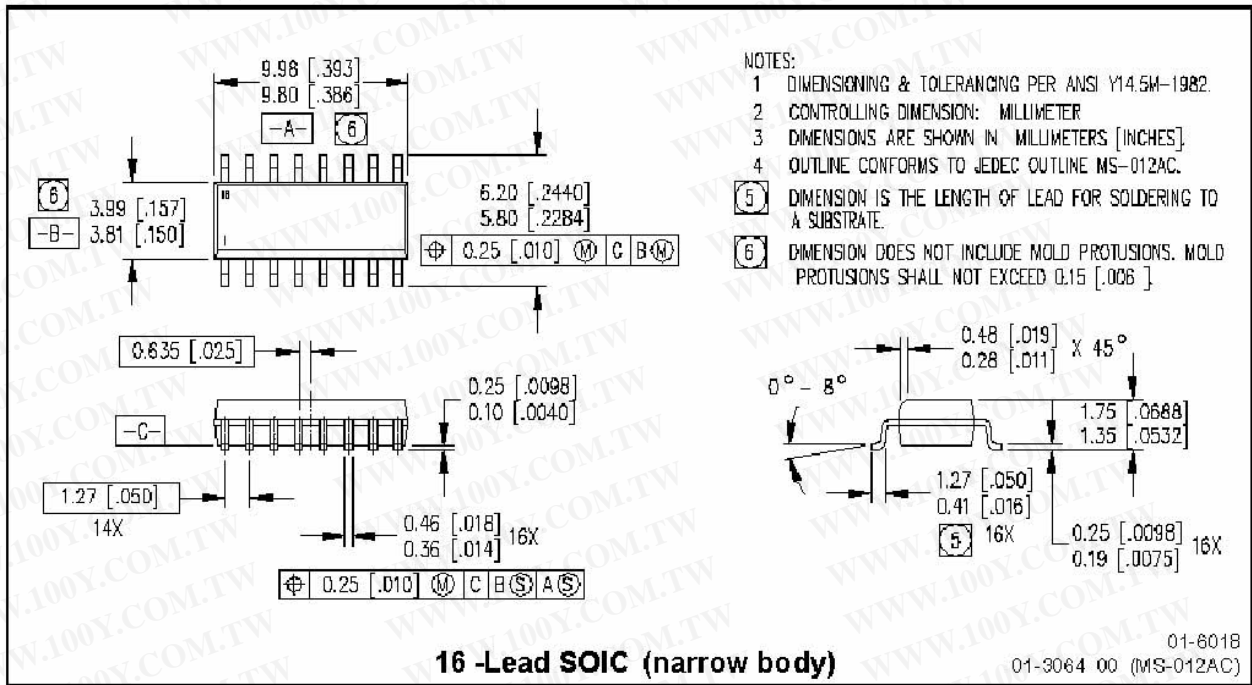

Figure 4: $V_{CSH} > V_{th_{oCH}}$ to Shutdown Waveform

Application information and additional information

Please refer to AN-1144 for IRS20957 functional description.

Package Details: SOIC16N



Package Details: SOIC16N, Tape and Reel

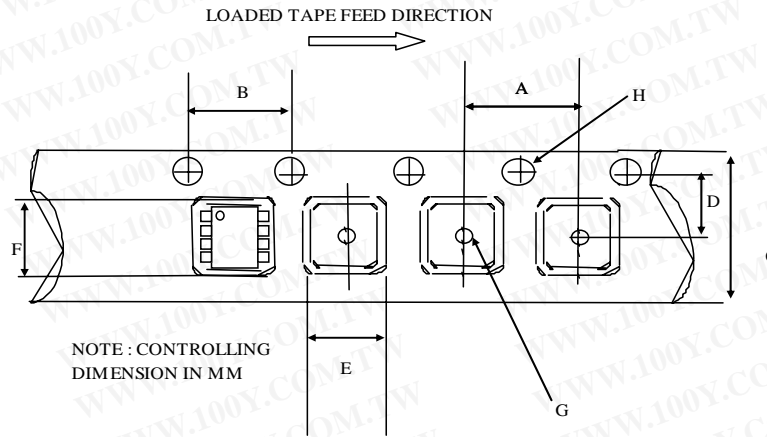

CARRIER TAPE DIMENSION FOR 16SOICN

Code	Metric		Imperial	
	Min	Max	Min	Max
A	7.90	8.10	0.311	0.318
B	3.90	4.10	0.153	0.161
C	15.70	16.30	0.618	0.641
D	7.40	7.60	0.291	0.299
E	6.40	6.60	0.252	0.260
F	10.20	10.40	0.402	0.409
G	1.50	n/a	0.059	n/a
H	1.50	1.60	0.059	0.062

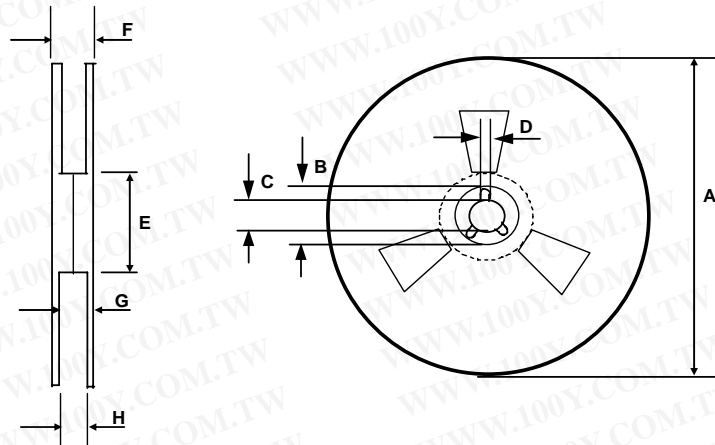

REEL DIMENSIONS FOR 16SOICN

Code	Metric		Imperial	
	Min	Max	Min	Max
A	329.60	330.25	12.976	13.001
B	20.95	21.45	0.824	0.844
C	12.80	13.20	0.503	0.519
D	1.95	2.45	0.767	0.096
E	98.00	102.00	3.858	4.015
F	n/a	22.40	n/a	0.881
G	18.50	21.10	0.728	0.830
H	16.40	18.40	0.645	0.724

Part Marking Information

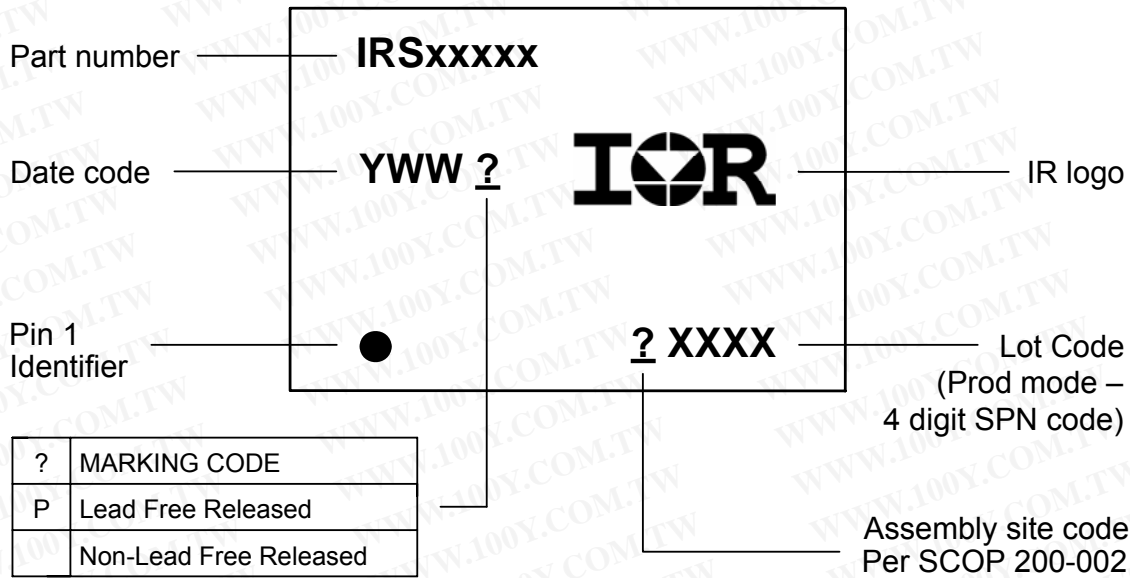

Ordering Information

Base Part Number	Package Type	Standard Pack		Complete Part Number
		Form	Quantity	
IRS20957S	SOIC16N	Tube/Bulk	45	IRS20957SPBF
		Tape and Reel	2500	IRS20957STRPBF

勝特力材料 886-3-5753170
 勝特力电子(上海) 86-21-34970699
 勝特力电子(深圳) 86-755-83298787
 Http://www.100y.com.tw

The information provided in this document is believed to be accurate and reliable. However, International Rectifier assumes no responsibility for the consequences of the use of this information. International Rectifier assumes no responsibility for any infringement of patents or of other rights of third parties which may result from the use of this information. No license is granted by implication or otherwise under any patent or patent rights of International Rectifier. The specifications mentioned in this document are subject to change without notice. This document supersedes and replaces all information previously supplied.

For technical support, please contact IR's Technical Assistance Center
<http://www.irf.com/technical-info/>

WORLD HEADQUARTERS:
 233 Kansas St., El Segundo, California 90245
 Tel: (310) 252-7105