

General Purpose PIR Controller

Features

- Operating voltage: 2.7V ~ 5.5V
- Standby current typical 17 μ A
- CDS input
- High noise immunity
- 40 second power-on delay
- 10 second high speed warm-up for test mode
- 1~3783 second adjustable PIR turn on time.
- Output drive for Relay, TRIAC and LED
- Output drive buzzer alarm
- Low voltage detector
- Override function
- 16-pin DIP/NSOP packages

Applications

- PIR light control
- Motion detectors
- Alarm system
- Auto door bells

General Description

The HT7612 is PIR controller specifically designed to interface to PIR sensors to implement motion sensing application products such as intruder alarms. The controller has the features of PIR sensitivity adjustment

and a CDS can be connected to the controller for automatic detection. The HT7612 is available in low profile NSOP & DIP packages.

Block Diagram

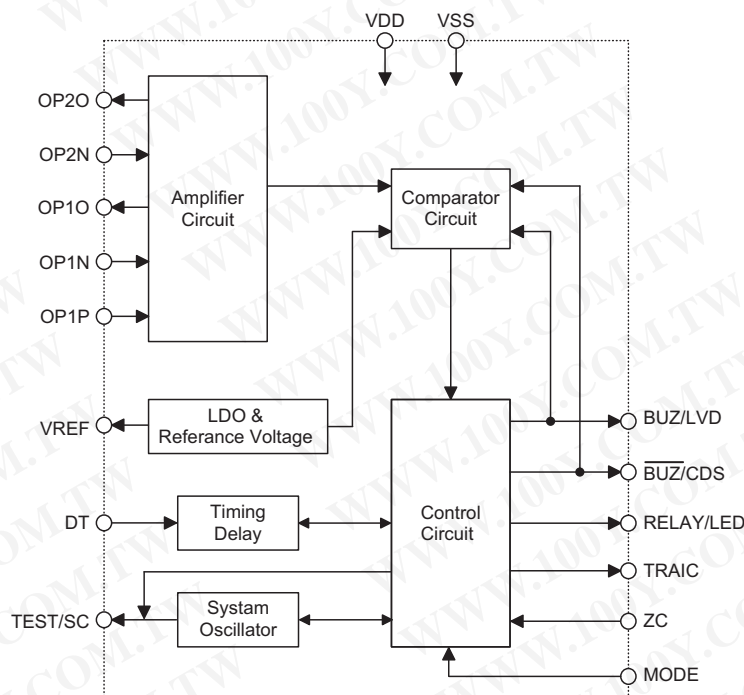

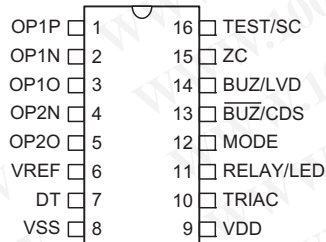
Pin Assignment

HT7612
16 DIP-A/NSOP-A

勝特力材料 886-3-5753170
勝特力电子(上海) 86-21-34970699
勝特力电子(深圳) 86-755-83298787
[Http://www.100y.com.tw](http://www.100y.com.tw)

Pin Description

Pin Name	I/O	Mask Option	Description
OP1P	I	PMOS	OP1 Non-inverting Input
OP1N	I	PMOS	OP1 Inverting Input
OP1O	O	CMOS	OP1 Output
OP2N	I	PMOS	OP2 Inverting Input
OP2O	O	CMOS	OP2 Output
Vref	O	NMOS	Reference Voltage
DT	I	PMOS	Delay time oscillator input. Connected to an external RC to adjust the output duration.
TEST/SC	O	CMOS	TEST and SC share the same pin. TEST is used to test the 32 KHz system frequency. SC is used to detect LVD and CDS.
VSS	—	—	Negative power supply, ground
VDD	—	—	Positive power supply
RELAY/LED	O	CMOS	RELAY and LED share the same pin. Active high - a RELAY is driven through an external NPN transistor.
BUZ/CDS	I/O	CMOS	BUZ and CDS share the same pin. The BUZ output can drive a piezo buzzer. CDS is connected to a CDS voltage divider for daytime/night auto-detection. A low input to this pin can disable the PIR input. CDS is connected to the input of a internal comparator with a 15~20second debounce time.
BUZ/LVD	I/O	CMOS	BUZ and LVD share the same pin. The BUZ output can drive a piezo buzzer. LVD is used as an input low voltage detector.
ZC	I	—	AC zero crossing detector input.
TRIAC	O	CMOS	TRIAC output drive. The output is a pulse output when active.
MODE	I	CMOS	Operating mode selection input. VDD: Output is always ON VSS: Output is always OFF Open: Auto detection Test Mode Input.

Absolute Maximum Ratings

Supply Voltage.....	$V_{SS}-0.3V$ to $V_{SS}+6.0V$	Storage Temperature.....	$-50^{\circ}C$ to $125^{\circ}C$
Input Voltage.....	$V_{SS}-0.3V$ to $V_{DD}+0.3V$	Operating Temperature.....	$-40^{\circ}C$ to $85^{\circ}C$
Zero Crossing Current.....	Max. $300\mu A$		

Note: These are stress ratings only. Stresses exceeding the range specified under "Absolute Maximum Ratings" may cause substantial damage to the device. Functional operation of this device at other conditions beyond those listed in the specification is not implied and prolonged exposure to extreme conditions may affect device reliability.

Electrical Characteristics

 $T_a=25^{\circ}C$

Symbol	Parameter	Test Conditions		Min.	Typ.	Max.	Unit
		V_{DD}	Conditions				
V_{DD}	Operating Voltage	—	—	2.7	4.0	5.5	V
V_{REF}	Reference Voltage - see Note	5V	$C_f=1\mu F$	3.201	3.300	3.399	V
I_{REF}	Driving Current	5V	—	200	—	—	μA
I_{STB}	Standby Current	5V	DT off, OPAMP off	—	17	23	μA
I_{OH1}	TRIAC Source Current	5V	$V_{OH}=4.5V$	-20	-40	—	mA
I_{OL1}	TRIAC Sink Current	5V	$V_{OL}=0.5V$	20	40	—	mA
I_{OH2}	BUZ & \overline{BUZ} Source Current	5V	$V_{OH}=4.5V$	-5	-10	—	mA
I_{OL2}	BUZ & \overline{BUZ} Sink Current	5V	$V_{OL}=0.5V$	10	20	—	mA
I_{OH3}	RELAY/LED Source Current	5V	$V_{OH}=4.5V$	-5	-10	—	mA
I_{OL3}	RELAY/LED Sink Current	5V	$V_{OL}=0.5V$	10	20	—	mA
V_{IH}	MODE High Input Voltage	—	—	$0.7V_{DD}$	—	—	V
V_{IL}	MODE Low Input Voltage	—	—	—	—	$0.3V_{DD}$	V
V_{TH1}	ZC High Transfer Voltage	—	—	$0.7V_{DD}$	—	—	V
V_{TL1}	ZC Low Transfer Voltage	—	—	—	—	$0.3V_{DD}$	V
V_{OS}	OP Amp Input Offset Voltage	5V	$C_L=10pF$	—	10	—	mV
V_{LVD}	Low Voltage Detector Voltage	—	—	0.99	1.10	1.21	V
f_{SYS}	System Oscillator Frequency - IRC	5V	—	28.8	32.0	35.2	kHz
f_{DT}	Delay Time Frequency - ERC	—	$V_{REF}, R_{DT}=30k\Omega,$ $C_{DT}=3000pF$	15.2	16.0	16.8	kHz
AVO	OP Amp Open Loop Gain	5V	$R_L=510k\Omega$ to V_{SS}	60	80	—	dB
GBW	OP Amp Gain Band Bandwidth	5V	$R_L=510k\Omega, C_L=100pF$	2.5	5.0	—	kHz
V_H	High Level Comparator Window	5V	$1/2 V_{REF} + 1/6 V_{REF}$	1.98	2.20	2.42	V
V_L	Low Level Comparator Window	5V	$1/2 V_{REF} - 1/6 V_{REF}$	0.99	1.10	1.21	V

Note: When V_{DD} is less than 3.4V, then the V_{REF} voltage will be equal to V_{DD} . If the V_{REF} voltage is less than the PIR working voltage, then the PIR sensor will not work normally.

Functional Description

The following gives a description of the functional pins on the device.

TEST

The TEST pin is an output which is used to test the 32 KHz system frequency. Note that the pin is a shared TEST/SC pin. The TEST output pin can be used within 1 second after power-on.

SC

The SC pin is an output pin which is used to for LVD and CDS detection. Note the pin is a shared TEST/SC pin. The SC pin can be used 1 second after power-on.

DT

The DT pin is a delay time oscillator input pin. It is connected to an external RC to obtain the desired output turn-on duration. Variable output turn-on durations can be achieved by selecting various values of RC or using a variable resistor. The DT structure is shown in Fig.1.

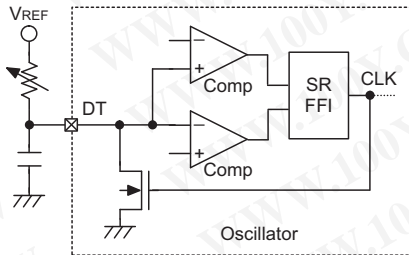

Fig.1 DT Oscillator Structure

BUZ/ $\overline{\text{BUZ}}$

The BUZ & $\overline{\text{BUZ}}$ pins are both CMOS output structures. They will output 4 beep sounds within 1second to indicate that the warm-up time has completed. These differential output pins can be used to drive a piezo buzzer. The BUZ/ $\overline{\text{BUZ}}$ structure are shown in Fig.2.

RELAY

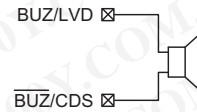

Fig.2 Buzzer Pin Drive Buzzer

The RELAY pin is a CMOS output structure which is normally low and active high. The high duration is controlled by the delay time oscillator and the MODE pin. The RELAY pin structure is shown in Fig.3.

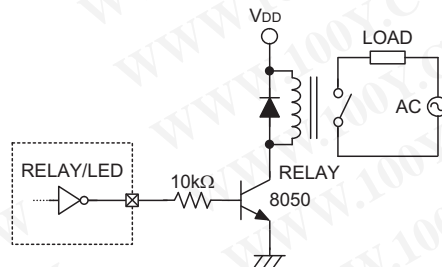

Fig.3 RELAY Pin Drive RELAY

TRIAC

The TRIAC pin is a CMOS output structure which will output a series of pulses when active. The pulse train is synchronised by the ZC (zero crossing) input. The active duration is controlled by the delay time oscillator and the MODE pin. The TRIAC structure is shown in Fig.4.

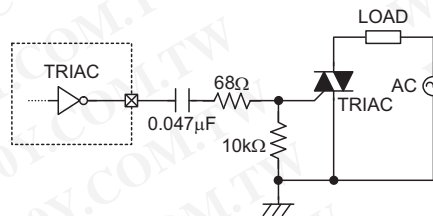

Fig.4 TRIAC Pin Drive TRIAC

MODE

The MODE pin is a tristate input which is used to select the desired device operating mode.

MODE pin Status	Operating Mode	Description
VDD	ON	Output is always ON: RELAY output high for RELAY driving. TRIAC pulse train output is synchronised by ZC for TRIAC driving.
VSS	OFF	Output is always OFF: RELAY output low for RELAY driving. TRIAC output low for TRIAC driving.
OPEN	AUTO	Outputs remain in the OFF state until activated by a valid PIR input trigger signal. When working in the AUTO mode, the devices allows for an override control by switching the ZC signal.

The device also provides an additional test function on the MODE pin. If the MODE pin is presented with a high pulse, of greater than 400ms duration, within 1 second after power-on, the device will be forced into its test mode. When the device enters the test mode the power-on delay time will be changed from its normal operating value of 40 seconds to 10 seconds.

ZC

The ZC pin is a CMOS Schmitt trigger input pin. Using suitable ZC signal switching, the device can provide the following functions:

- Override control

When the device is operating in the AUTO mode, which is when the MODE pin is open, the output will be activated by a valid PIR trigger signal and the output active duration will be controlled by a DT oscillating period. The mode can be switched from the AUTO mode to the "ON" mode by either connecting the MODE pin to VDD or switching the ZC signal with an OFF/ON operation of the power switch. The term "override" refers to the change of operating mode by switching the power switch. The device can be toggled from ON to AUTO by an override operation. If the

device is overridden to ON and there is no further override operations, it will automatically return to the AUTO mode after 8 hours. It will flash 3 times at a 1Hz rate when returning to the AUTO mode. But if the AUTO mode is changed by switching the MODE switch, it will not flash, as shown in Fig.5.

In Fig.6, an external pull-high resistor is required for normal applications.

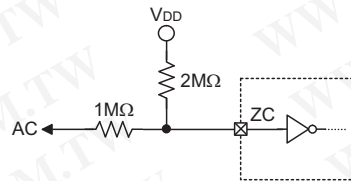

Fig.6 ZC Application Example

Note: Regarding the priority of the MODE pin and the ZC switching, note that when the MODE pin is connected to VDD or VSS, the MODE state will be determined by the MODE pin. When the MODE pin is OPEN, the MODE state will be determined by the ZC switching.

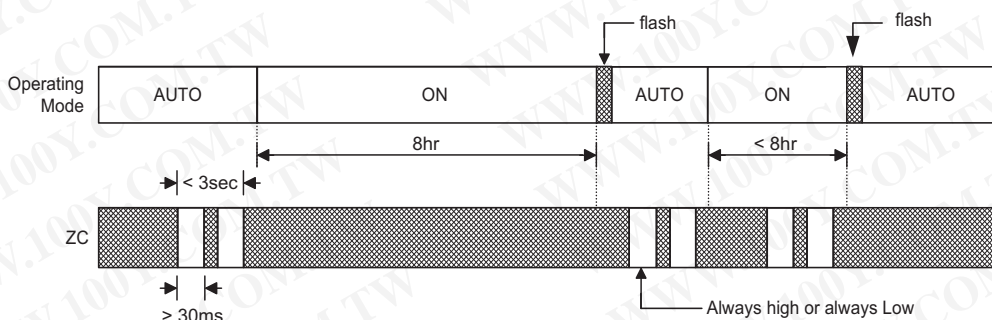

Fig.5 ZC Override Timing

CDS

The CDS pin is connected to an internal comparator input. It is used to allow the device to distinguish between day and night conditions. When the CDS input voltage is lower than V_L , the PIR amplifier circuit will be disabled and the TRIAC and RELAY output pins will be inactive. When the input voltage of the CDS is higher than V_L , the outputs are both active. The debounce time for the CDS pin for switching the outputs from an inactive to an active state is about 15~20 seconds. Connect this pin to VDD when this function is not used. The CDS timing is shown in Fig.7

CDS	Status	Output
Low	Day Time	Disabled
High	Night	Enabled

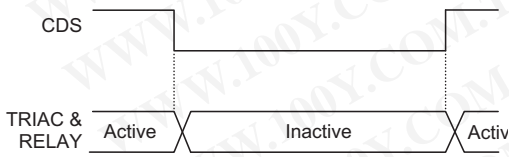

Fig.7 CDS Timing

In Fig.8, R_{CDS} and R_y can be adjusted to obtain the desired daytime detection level.

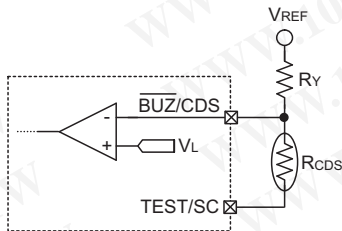

Fig.8 CDS Application Example

LED

The LED pin is a CMOS output pin which is used as a valid trigger indicator. When the TRIAC/RELAY is activated, this pin will be active until the TRIAC/RELAY has is switched OFF. The LED pin structure is shown in Fig.9.

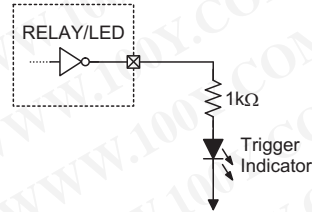

Fig. 9 LED Pin Drive LED

LVD

LVD is a low voltage detector. When the detected voltage is lower than 1.1V, the LED flicker and the buzzer will emit a tone.

In Fig10, assume R_x , R_{LVD} can be adjusted to obtain the desired voltage detection level.

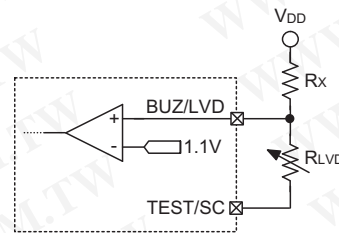
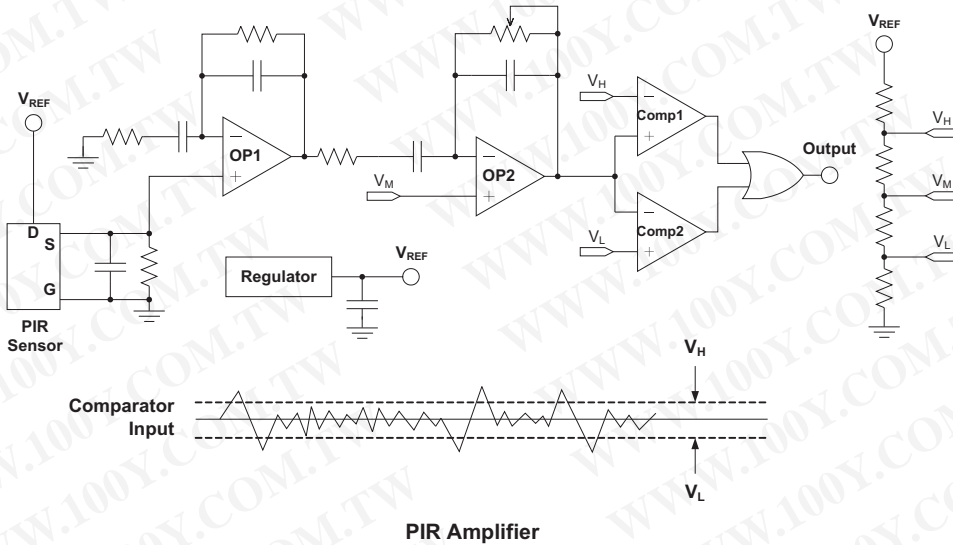

Fig.10 LVD Application Example



PIR Amplifier

Effective Trigger Timing

The effective input trigger signal width should be $\geq 24\text{ms}$. The output is valid either with (1) trigger signal width ≥ 0.5 seconds or (2) more than 2 effective trigger inputs within 2 seconds (separation of 2 triggers $\geq 0.5\text{s}$). The separation time between two TRIAC(RELAY) turn-on time must be more than 1 sec. The trigger timing is shown in Fig.11.

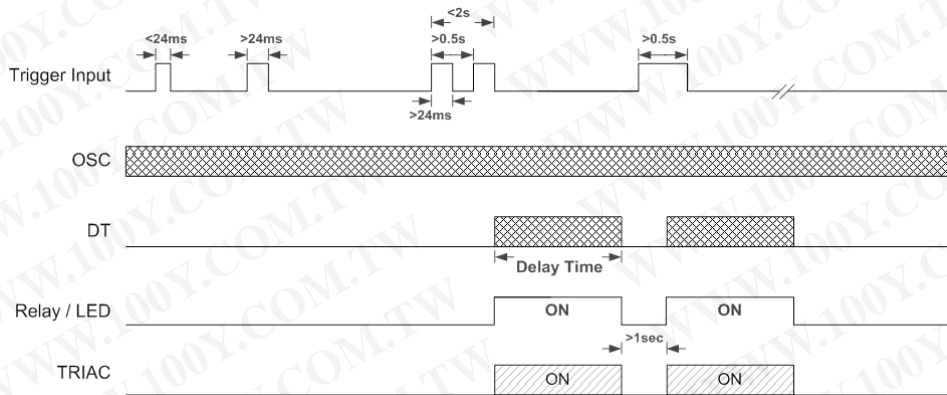

Fig.11 Trigger Timing

Retrigger

When the output of the comparator is a valid signal, the RELAY/TRIAC will be activated and the active duration is controlled by the DT oscillating period. If the previous "Delay Time t_D " has not been exceeded and the next valid signal occurs again, the active duration of the RELAY/TRIAC will be restarted. The timing is shown in Fig.12.

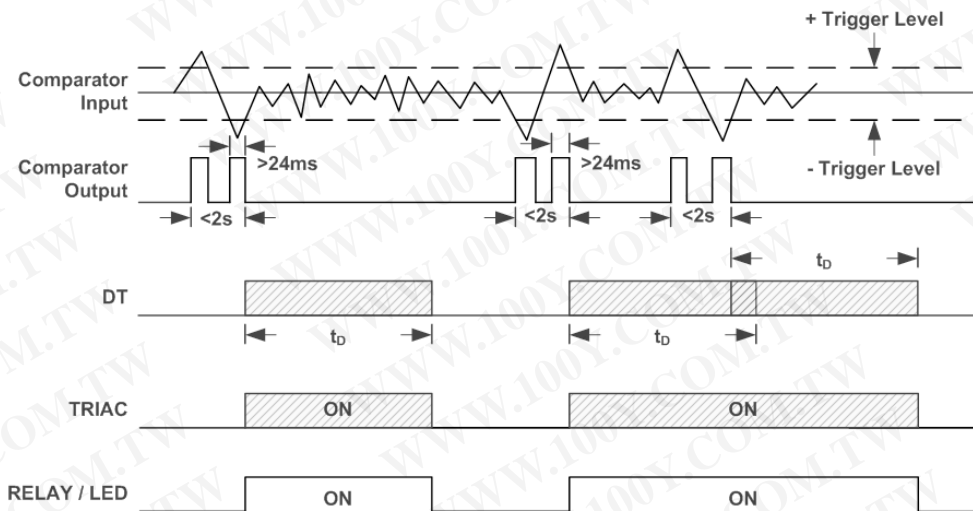

Fig.12 Retrigger

LVD & CDS Detecting Circuit

The external and internal detecting circuits for LVD and CDS are shown in Fig.13. When the input voltage V_{LVD} is lower than 1.1V, the comparator outputs a low level which means that V_{DD} is lower than the minimum operating voltage (V_{min}). When V_{CDS} is lower than V_L , the comparator outputs a high level which means that it is daytime, otherwise it is night.

Where

$$V_{LVD} = \frac{R_{LVD}}{R_{LVD} + R_X} V_{DD}$$

$$V_{CDS} = \frac{R_{CDS}}{R_{CDS} + R_Y} V_{REF}$$

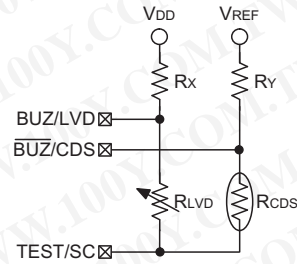

Fig.13 External Application Circuit

Note: When the CDS input voltage is lower than V_L , it means that a daytime condition exists for the PIR circuit.

The Criterion of LVD and CDS

The LVD and CDS trigger timing are shown in Fig.14 and Fig.15 respectively. In Fig.14, When an LVD condition occurs, the LED will flicker and the buzzer will emit a tone. In Fig.15, When the CDS changes from high to low, the output of the PIR is high after 10sec, and when the CDS changes from low to high, will be low.

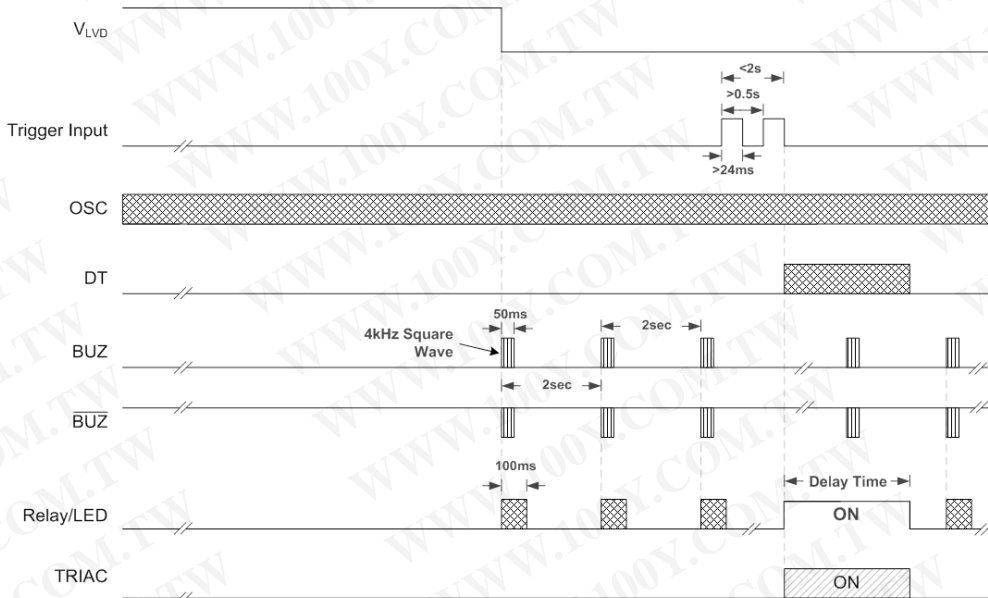

Fig.14 Trigger Timing of LVD

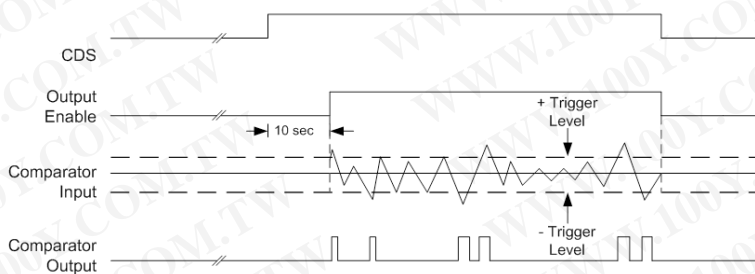
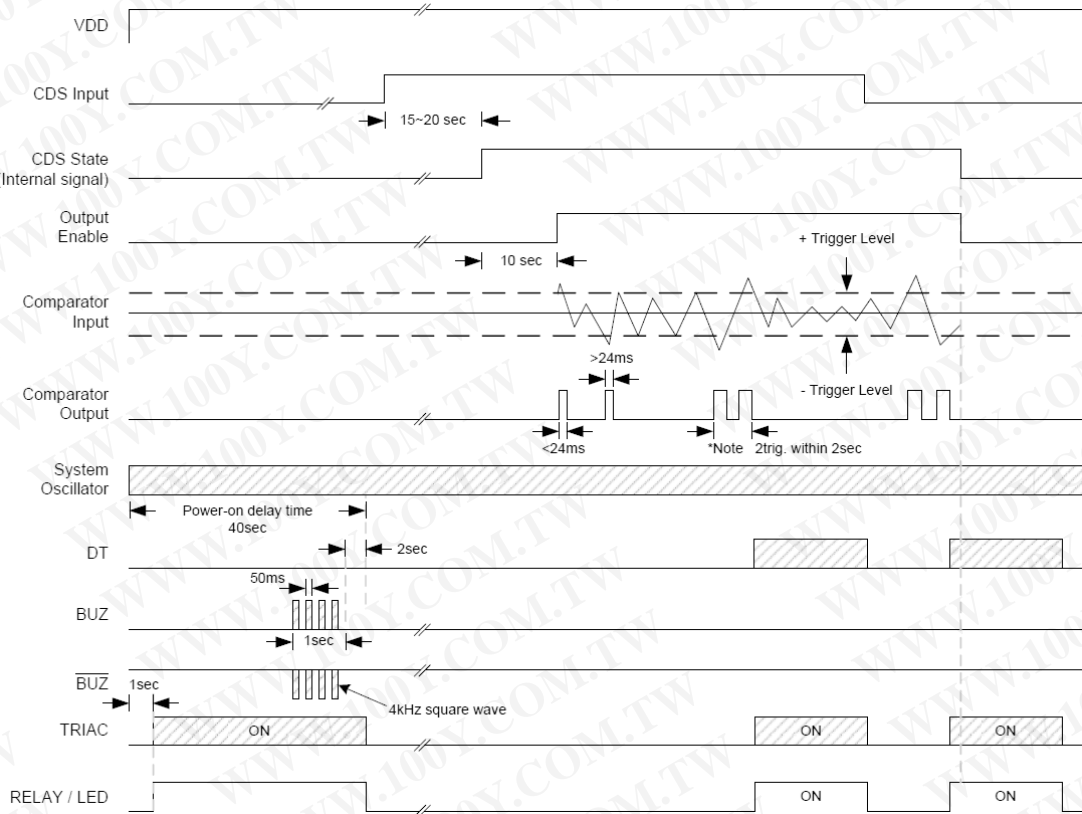

Fig.15 Trigger Timing of CDS

Trigger Timing



Note: The output is activated if the trigger signal conforms to the following criteria:

1. Two triggers occur within 2 seconds and separation time between two triggers is more than 0.5sec.

勝特力材料 886-3-5753170
勝特力电子(上海) 86-21-34970699
勝特力电子(深圳) 86-755-83298787
Http://www.100y.com.tw

Application Circuit

AC Power Application

- TRIAC

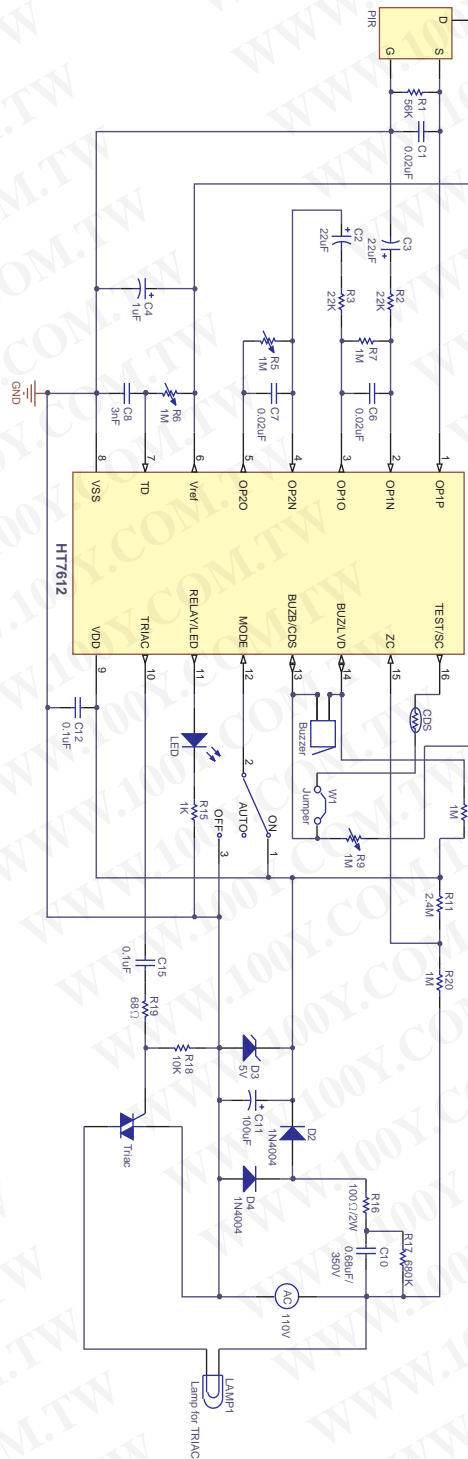

勝特力材料 886-3-5753170
 勝特力电子(上海) 86-21-34970699
 勝特力电子(深圳) 86-755-83298787
[Http://www.100y.com.tw](http://www.100y.com.tw)

Note: Adjust R9 to fit various CDS.
 Adjust R6 to obtain the desired output duration.
 Adjust R5 to change PIR sensitivity.
 Change the value of C10 to 0.33 μ F/600V for AC 220V application.

• RELAY

勝特力材料 886-3-5753170
 勝特力电子(上海) 86-21-34970699
 勝特力电子(深圳) 86-755-83298787
 Http://www.100y.com.tw

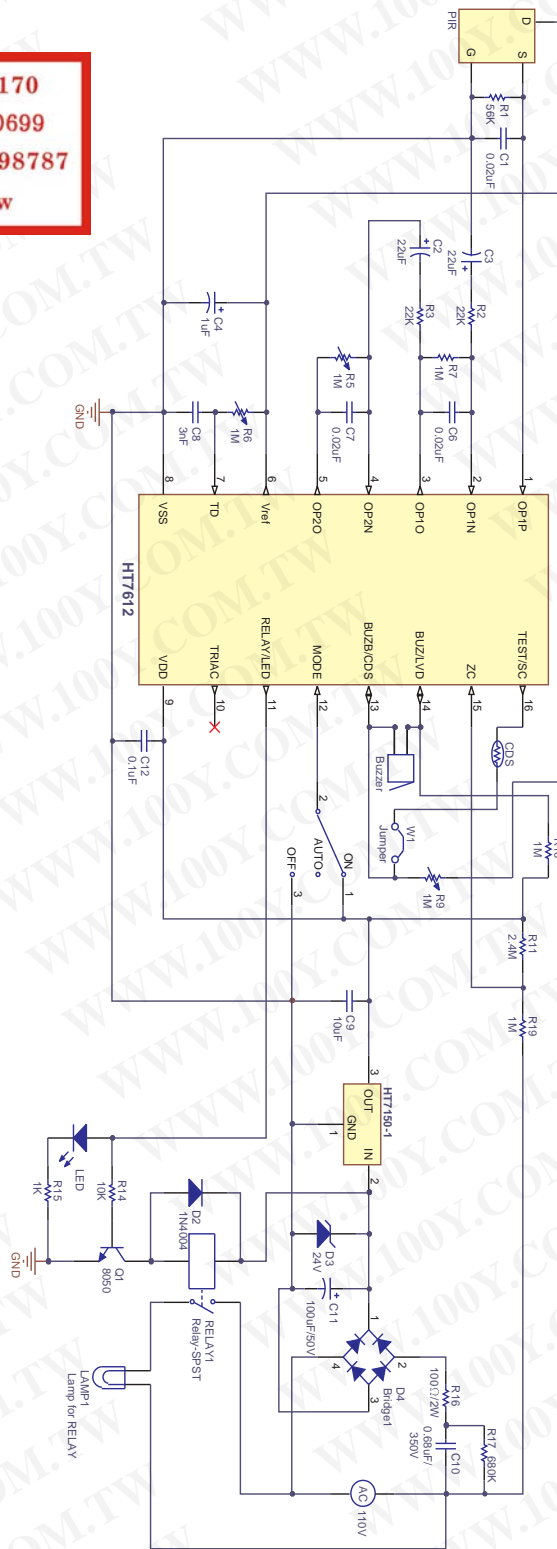

Note: Adjust R9 to fit various CDS.
 Adjust R6 to obtain the desired output duration.
 Adjust R5 to change PIR sensitivity.
 Change the value of C10 to 0.33 μ F/600V for AC 220V application.

Photo-transistor Application Circuit

勝特力材料 886-3-5753170
 勝特力电子(上海) 86-21-34970699
 勝特力电子(深圳) 86-755-83298787
 Http://www.100y.com.tw

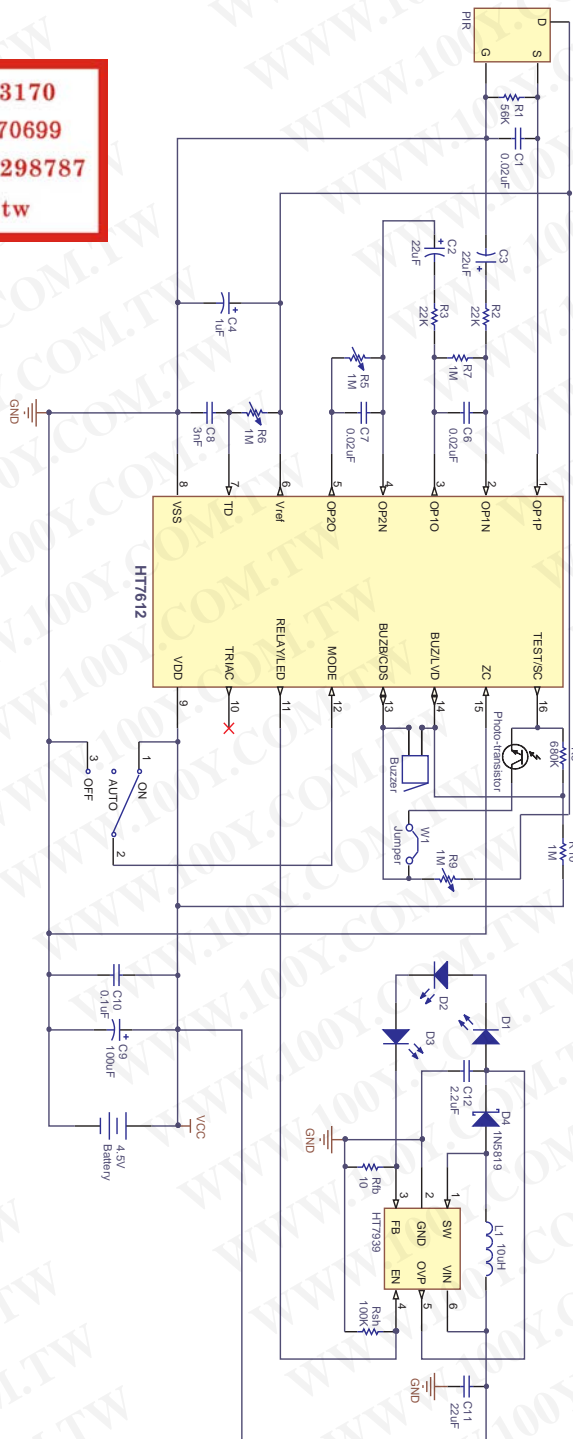

Note: Adjust R9 to fit various CDS.
 Adjust R6 to obtain the desired output duration.
 Adjust R5 to change PIR sensitivity.
 Use a Photo-transistor instead of a CDS to meet European RoHS standards.

Package Information

16-pin DIP (300mil) Outline Dimensions

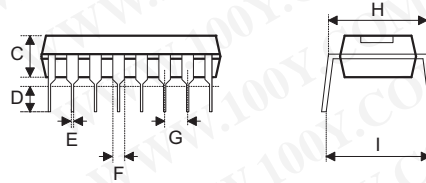
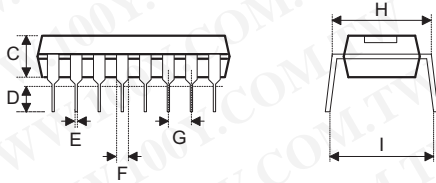
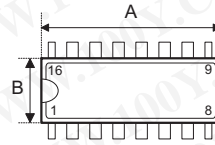
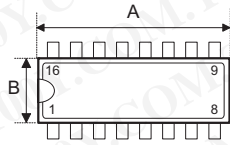

Fig1. Full Lead Packages

Fig2. 1/2 Lead Packages

- MS-001d (see fig1)

Symbol	Dimensions in inch		
	Min.	Nom.	Max.
A	0.780	—	0.880
B	0.240	—	0.280
C	0.115	—	0.195
D	0.115	—	0.150
E	0.014	—	0.022
F	0.045	—	0.070
G	—	0.100	—
H	0.300	—	0.325
I	—	—	0.430

Symbol	Dimensions in mm		
	Min.	Nom.	Max.
A	19.81	—	22.35
B	6.10	—	7.11
C	2.92	—	4.95
D	2.92	—	3.81
E	0.36	—	0.56
F	1.14	—	1.78
G	—	2.54	—
H	7.62	—	8.26
I	—	—	10.92

- MS-001d (see fig2)

Symbol	Dimensions in inch		
	Min.	Nom.	Max.
A	0.735	—	0.775
B	0.240	—	0.280
C	0.115	—	0.195
D	0.115	—	0.150
E	0.014	—	0.022
F	0.045	—	0.070
G	—	0.100	—
H	0.300	—	0.325
I	—	—	0.430

Symbol	Dimensions in mm		
	Min.	Nom.	Max.
A	18.67	—	19.69
B	6.10	—	7.11
C	2.92	—	4.95
D	2.92	—	3.81
E	0.36	—	0.56
F	1.14	—	1.78
G	—	2.54	—
H	7.62	—	8.26
I	—	—	10.92

勝特力材料 886-3-5753170
 勝特力电子(上海) 86-21-34970699
 勝特力电子(深圳) 86-755-83298787
[Http://www.100y.com.tw](http://www.100y.com.tw)

- MO-095a (see fig2)

Symbol	Dimensions in inch		
	Min.	Nom.	Max.
A	0.745	—	0.785
B	0.275	—	0.295
C	0.120	—	0.150
D	0.110	—	0.150
E	0.014	—	0.022
F	0.045	—	0.060
G	—	0.100	—
H	0.300	—	0.325
I	—	—	0.430

Symbol	Dimensions in mm		
	Min.	Nom.	Max.
A	18.92	—	19.94
B	6.99	—	7.49
C	3.05	—	3.81
D	2.79	—	3.81
E	0.36	—	0.56
F	1.14	—	1.52
G	—	2.54	—
H	7.62	—	8.26
I	—	—	10.92

勝特力材料 886-3-5753170
 勝特力电子(上海) 86-21-34970699
 勝特力电子(深圳) 86-755-83298787
[Http://www.100y.com.tw](http://www.100y.com.tw)

16-pin NSOP (150mil) Outline Dimensions

勝特力材料 886-3-5753170
 勝特力电子(上海) 86-21-34970699
 勝特力电子(深圳) 86-755-83298787
[Http://www.100y.com.tw](http://www.100y.com.tw)

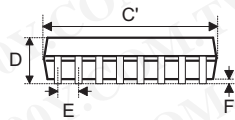
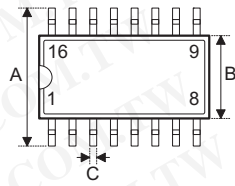

• MS-012

Symbol	Dimensions in inch		
	Min.	Nom.	Max.
A	0.228	—	0.244
B	0.150	—	0.157
C	0.012	—	0.020
C'	0.386	—	0.402
D	—	—	0.069
E	—	0.050	—
F	0.004	—	0.010
G	0.016	—	0.050
H	0.007	—	0.010
α	0°	—	8°

Symbol	Dimensions in mm		
	Min.	Nom.	Max.
A	5.79	—	6.20
B	3.81	—	3.99
C	0.30	—	0.51
C'	9.80	—	10.21
D	—	—	1.75
E	—	1.27	—
F	0.10	—	0.25
G	0.41	—	1.27
H	0.18	—	0.25
α	0°	—	8°

Product Tape and Reel Specifications

Reel Dimensions

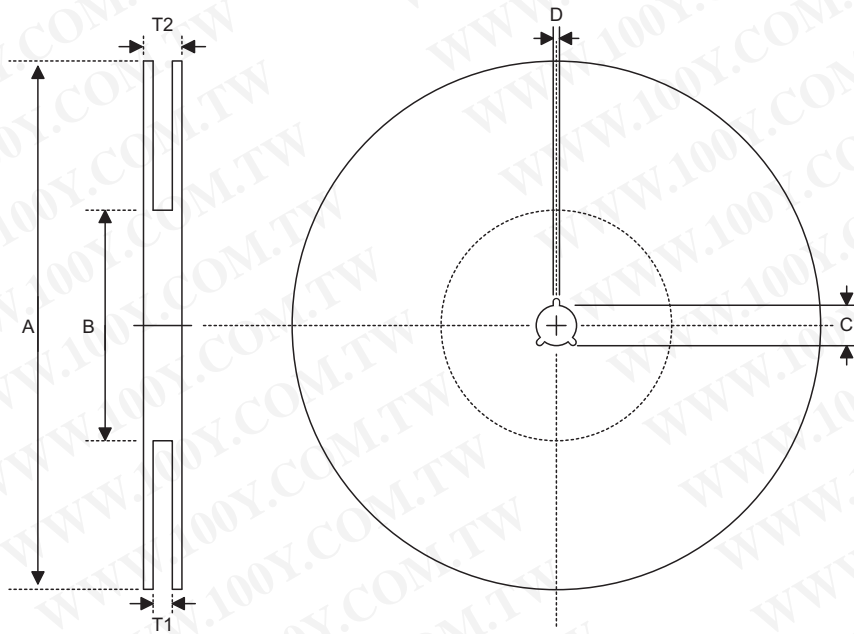

SOP 16N (150mil)

Symbol	Description	Dimensions in mm
A	Reel Outer Diameter	330.0±1.0
B	Reel Inner Diameter	100.0±1.5
C	Spindle Hole Diameter	13.0 ^{+0.5/-0.2}
D	Key Slit Width	2.0±0.5
T1	Space Between Flange	16.8 ^{+0.3/-0.2}
T2	Reel Thickness	22.2±0.2

勝特力材料 886-3-5753170
勝特力电子(上海) 86-21-34970699
勝特力电子(深圳) 86-755-83298787
Http://www.100y.com.tw

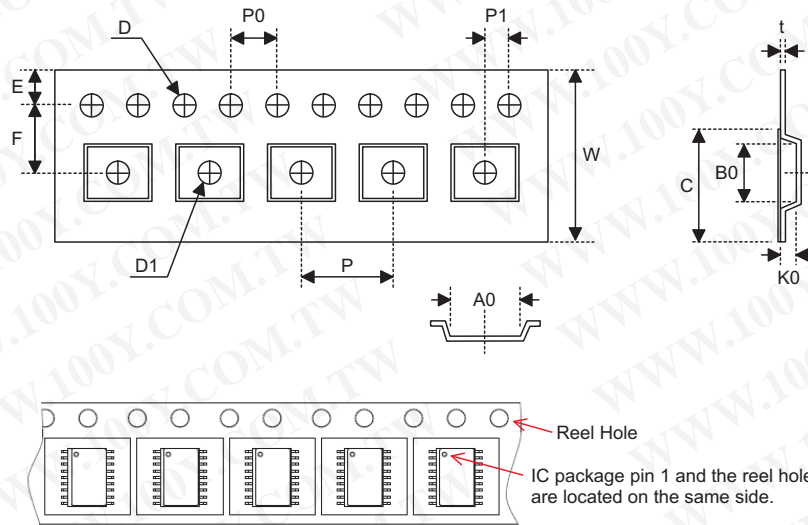
Carrier Tape Dimensions

SOP 16N (150mil)

Symbol	Description	Dimensions in mm
W	Carrier Tape Width	16.0±0.3
P	Cavity Pitch	8.0±0.1
E	Perforation Position	1.75±0.1
F	Cavity to Perforation (Width Direction)	7.5±0.1
D	Perforation Diameter	1.55 ^{+0.10/-0.00}
D1	Cavity Hole Diameter	1.50 ^{+0.25/-0.00}
P0	Perforation Pitch	4.0±0.1
P1	Cavity to Perforation (Length Direction)	2.0±0.1
A0	Cavity Length	6.5±0.1
B0	Cavity Width	10.3±0.1
K0	Cavity Depth	2.1±0.1
t	Carrier Tape Thickness	0.30±0.05
C	Cover Tape Width	13.3±0.1

勝特力材料 886-3-5753170
勝特力电子(上海) 86-21-34970699
勝特力电子(深圳) 86-755-83298787
[Http://www.100y.com.tw](http://www.100y.com.tw)