

# MOS INTEGRATED CIRCUIT

# $\mu$ PD78C10A, 78C11A, 78C12A

## 8-BIT SINGLE-CHIP MICROCOMPUTER (WITH A/D CONVERTER)

### DESCRIPTION

The  $\mu$ PD78C11A is a CMOS 8-bit microprocessor which can integrate 16-bit ALU, ROM, RAM, an A/D converter, a multi-function timer/event counter, and a general-purpose serial interface into a single chip, then expand the memory (ROM/RAM) up to 60K bytes externally. The  $\mu$ PD78C10A is a ROM-less product of the  $\mu$ PD78C11A, and can directly address the external memory up to 64k bytes. The  $\mu$ PD78C12A is a product which has more built-in ROM capacity than the  $\mu$ PD78C11A, and its memory (ROM/RAM) can be externally extended up to 56K bytes. The  $\mu$ PD78C10A,  $\mu$ PD78C11A, and  $\mu$ PD78C12A operated at low power consumption, because they have a CMOS construction. Also, they can hold data with low power consumption by using standby function.

On-chip PROM products,  $\mu$ PD78CP14 and  $\mu$ PD78CP18 which are ideal for evaluation or preproduction use during system development, early start-up and short-run multiple-device production of application sets, are available.

### FEATURES

- Abundant 159 types of instructions : 87AD series instruction set, multiplication/division instructions, 16-bit operation instructions
- Instruction cycle : 0.8  $\mu$ s (at 15 MHz operation)
- On-chip ROM : 4096W  $\times$  8 ( $\mu$ PD78C11A), 8192W  $\times$  8 ( $\mu$ PD78C12A)  
Non ( $\mu$ PD78C10A)
- On-chip RAM : 256W  $\times$  8
- High-precision 8-bit A/D converter : 8 analog inputs
- General-purpose serial interface : Asynchronous, synchronous, I/O interface mode
- Multi-function 16-bit timer/event counter
- Two 8-bit timers
- I/O lines : 32 ( $\mu$ PD78C10A), 44 ( $\mu$ PD78C11A, 78C12A)
- Interrupt function (external - 3, internal - 8) : Non-maskable interrupt  $\times$  1, maskable interrupt  $\times$  10
- Standby function : HALT mode, hardware/software STOP mode
- Zero-cross detection function : (2 inputs)
- On-chip pull-up resistor (port A, B, C:  $\mu$ PD78C11A, 78C12A only) by mask option

**Caution** The  $\mu$ PD78C10A does not have a mask option.

勝特力材料 886-3-5753170  
 勝特力电子(上海) 86-21-34970699  
 勝特力电子(深圳) 86-755-83298787  
[Http://www.100y.com.tw](http://www.100y.com.tw)

The information in this document is subject to change without notice.

**ORDERING INFORMATION**

Ordering Code	Package	On-Chip ROM
μPD78C10ACW	64-pin plastic shrink DIP (750 mil)	None
μPD78C10AGF-3BE	64-pin plastic QFP (14 × 20 mm)	None
μPD78C10AGQ-36	64-pin plastic QUIP	None
μPD78C10AL	68-pin plastic QFJ (□ 950 mil)	None
μPD78C11ACW-xxx	64-pin plastic shirink DIP (750 mil)	Mask ROM
μPD78C11AGF-xxx-3BE	64-pin plastic QFP (14 × 20 mm)	Mask ROM
μPD78C11AGQ-xxx-36	64-pin plastic QUIP	Mask ROM
μPD78C11AGQ-xxx-37	64-pin plastic QUIP straight	Mask ROM
μPD78C11AL-xxx	68-pin plastic QFJ (□ 950 mil)	Mask ROM
μPD78C12ACW-xxx	64-pin plastic shrink DIP (750 mil)	Mask ROM
μPD78C12AGF-xxx-3BE	64-pin plastic QFP (14 × 20 mm)	Mask ROM
μPD78C12AGQ-xxx-36	64-pin plastic QUIP	Mask ROM
μPD78C12AGQ-xxx-37	64-pin plastic QUIP straight	Mask ROM
μPD78C12AL-xxx	68-pin plastic QFJ (□ 950 mil)	Mask ROM

**PIN CONFIGURATION (TOP VIEW)**

- For μPD78C10ACW, μPD78C10AGQ-36, μPD78C11ACW-xxx, μPD78C11AGQ-xxx-36/37, μPD78C12ACW-xxx, μPD78C12AGQ-xxx-36/37.

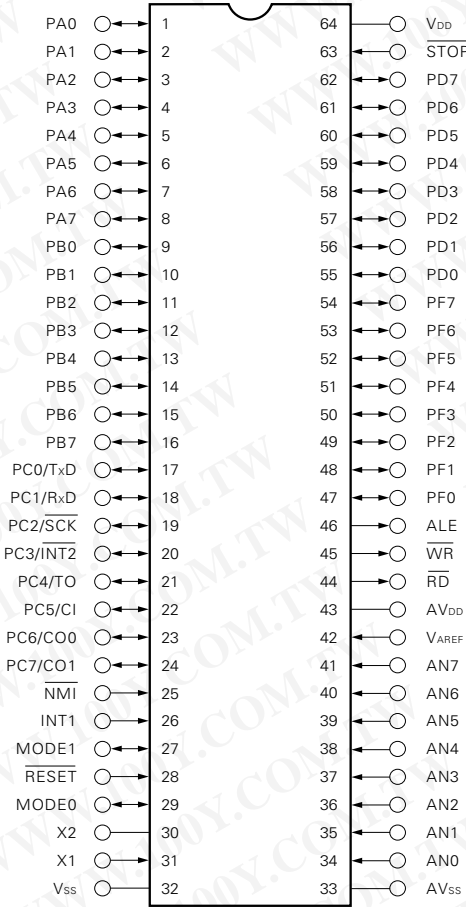

- For μPD78C10AGF-3BE, μPD78C11AGF-xxx-3BE, μPD78C12AGF-xxx-3BE

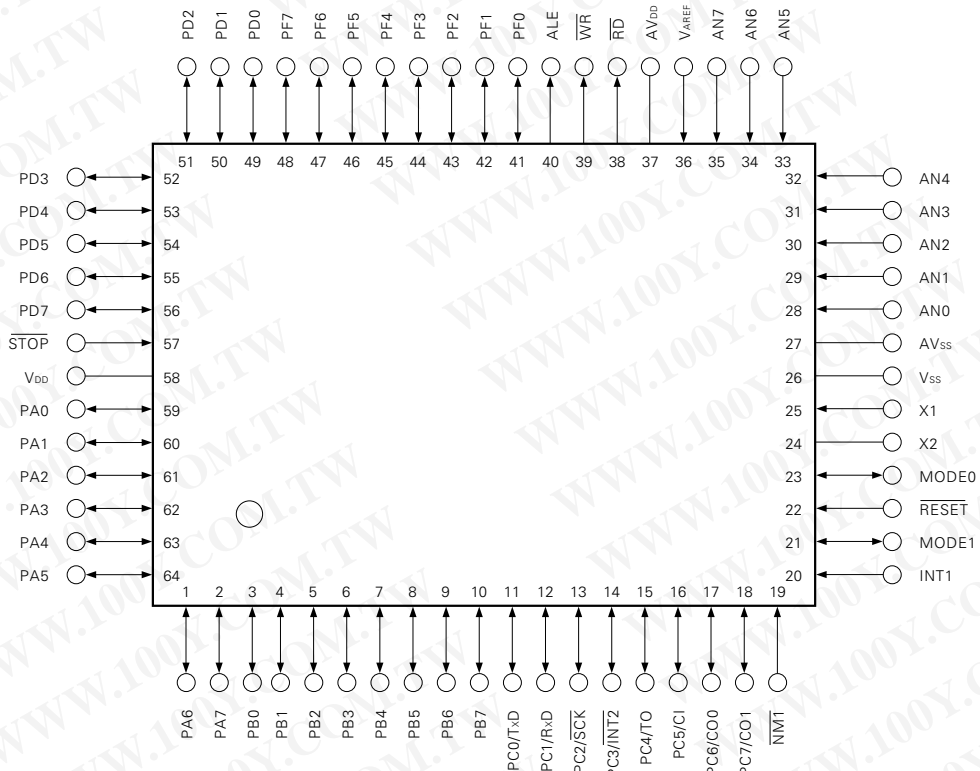

- For μPD78C10AL, μPD78C11AL-xxx, μPD78C12AL-xxx

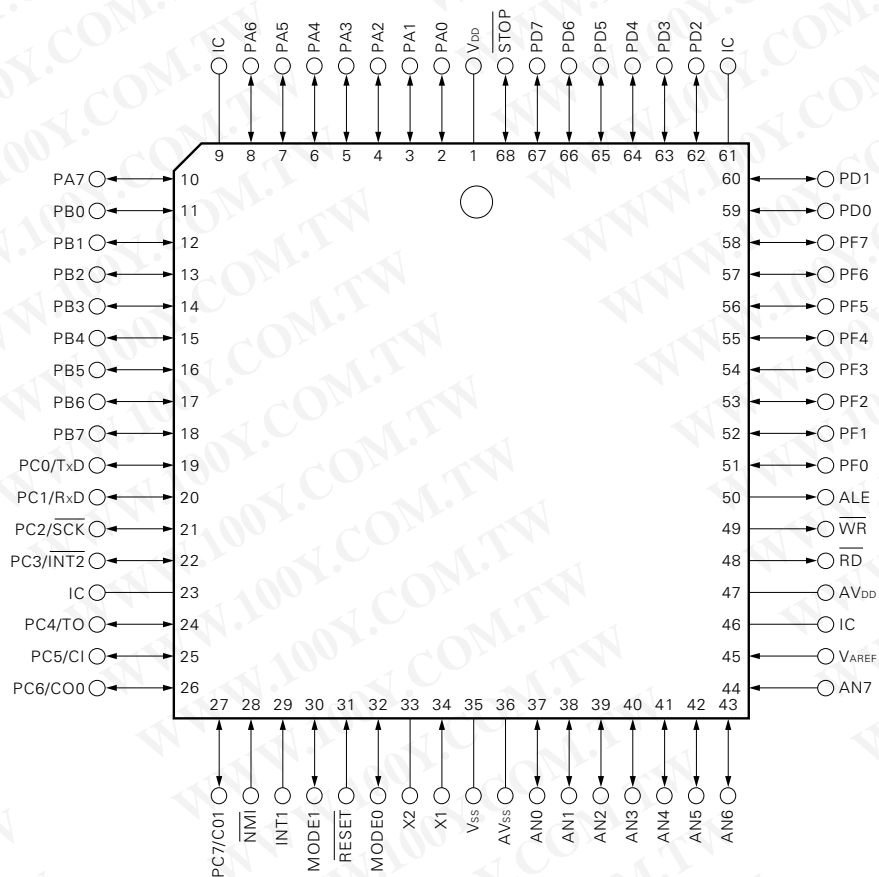

BLOCK DIAGRAM

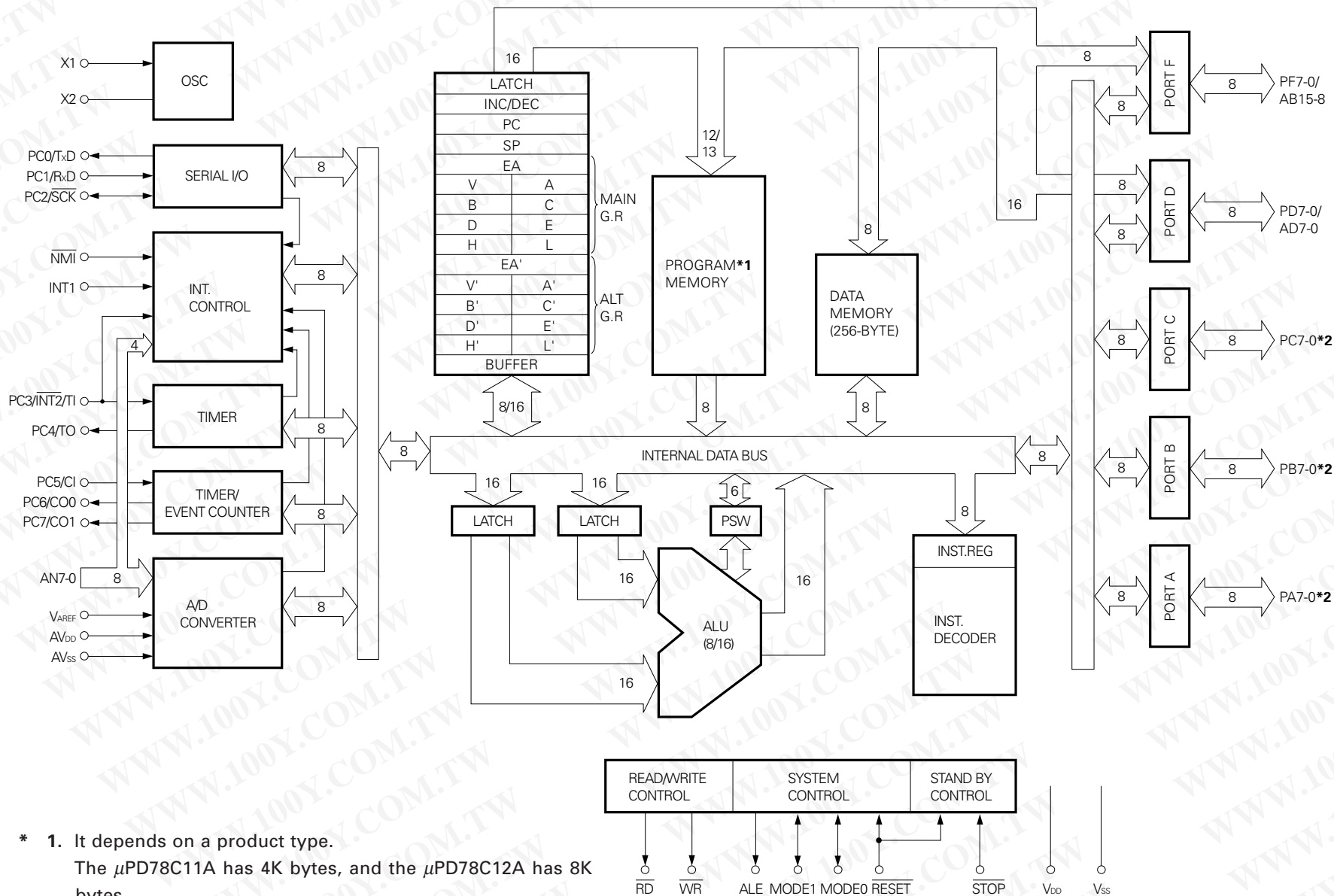

- \* 1. It depends on a product type.  
 The μPD78C11A has 4K bytes, and the μPD78C12A has 8K bytes.  
 The μPD78C10A does not incorporate a program memory.
2. An on-chip pull-up resistor is available by mask option (μPD78C11A, 78C12A only).

**CONTENTS**

**1. PIN FUNCTIONS ..... 7**

**1.1 LIST OF PIN FUNCTION ..... 7**

**1.2 PIN INPUT/OUTPUT CIRCUITS ..... 9**

**1.3 PIN MASK OPTIONS ..... 14**

**1.4 RECOMMENDED CONNECTION OF UNUSED PINS ..... 14**

**2. DIFFERENCES BETWEEN μPD78C10A AND μPD78C11A, 78C12A ..... 15**

**3. RESET OPERATIONS ..... 17**

**4. INSTRUCTION SET ..... 20**

**4.1 IDENTIFIER/DESCRIPTION OF OPERAND ..... 20**

**4.2 SYMBOL DESCRIPTION OF OPERATION CODE ..... 21**

**4.3 INSTRUCTION EXECUTION TIME ..... 22**

**5. LIST OF MODE REGISTERS ..... 34**

**6. ELECTRICAL SPECIFICATIONS ..... 35**

**7. CHARACTERISTIC CURVES (REFERENCE VALUES) ..... 47**

**8. DIFFERENCES IN 87AD SERIES PRODUCTS ..... 50**

**9. PACKAGE INFORMATION ..... 54**

**10. RECOMMENDED SOLDERING CONDITIONS ..... 60**

**APPENDIX DEVELOPMENT TOOLS ..... 62**

1. PIN FUNCTIONS

1.1 LIST OF PIN FUNCTION (1/2)

Pin Name	I/O	Function	
PA7 to PA0 (Port A)	Input/Output	8-bit input-output port, which can specify input/output bit-wise.	
PB7 to PB0 (Port B)	Input/Output	8-bit input-output port, which can specify input/output bit-wise.	
PC0/TxD	Input-output/ Output	Port C 8-bit input-output port, which can specify input/ output bit-wise.	Transmit Data Output pin for serial data.
PC1/RxD	Input-output/ Input		Receive Data Input pin for serial data.
PC2/SCK	Input-output/ Input-output		Serial Clock Input-output pin for serial clock. It becomes output clock for the internal clock use, and input for the external.
PC3/INT2/TI	Input-output/ Input/Input		Interrupt Request/Timer Input Maskable interrut input pin of the edge trigger (falling edge), or an external clock input pin for a timer. Also, it can be used as a zero-cross detection pin for AC input.
PC4/TO	Input-output/ Output		Timer Output Square wave defining one cycle of internal clock or timer counter time as half cycle is output.
PC5/CI	Input-output/ Input		Counter Input External pulse input pin to timer/event counter.
PC6/CO0 PC7/CO1	Input-output/ Output		Counter Output 0, 1 Programmable rectangle wave output by timer/event counter.
PD7 to PD0/ AD7 to AD0	Input-output/ Input-output		Port D 8-bit input-output port, which can specify input-output in byte units (μPD78C11A).
PF7 to PF0/ AB15 to AB8	Input-output/ Output	Port F 8-bit input-output port, which can specify input-output bit-wise.	Address Bus When external memory is used, it be- comes address bus.
$\overline{WR}$ (Write Strobe)	Output	Strobe signal which is output for write operation of external memory. It becomes high in any cycle other than the data write machine cycle of external memory. When RESET signal is either low or in the hardware STOP mode, this signal becomes output high-impedance.	
$\overline{RD}$ (Read Strobe)	Output	Strobe signal which is output for read operation of external memory. It becomes high in any cycle other than the read machine cycle of external memory. When RESET signal is either low or in the hardware STOP mode, this signal becomes output high-impedance.	
ALE (Address Latch Enable)	Output	Strobe signal to latch externally the lower address information which is output to PD7 to PD0 pins to access external memory. When RESET signal is either low or in the hardware STOP mode, this signal becomes output high-impedance.	

1.1 LIST OF PIN FUNCTION (2/2)

Pin Name	I/O	Function												
MODE0 MODE1 (Mode)	Input-output	<p>μPD78C11A and 78C12A sets MODE0 pin to "0" (low level), and MODE1 pin to "1" (high level*)</p> <p>μPD78C10A allows you to set MODE0, MODE1 pins to select 4K, 16K, or 64K bytes for the size of the memory which is installed externally.</p> <table border="1" style="margin-left: auto; margin-right: auto;"> <thead> <tr> <th>MODE0</th> <th>MODE1</th> <th>External Memory</th> </tr> </thead> <tbody> <tr> <td>0</td> <td>0</td> <td>4K bytes</td> </tr> <tr> <td>1</td> <td>0</td> <td>16K bytes</td> </tr> <tr> <td>1</td> <td>1</td> <td>64K bytes</td> </tr> </tbody> </table> <p>Also, when each of MODE0 and MODE1 pins is set to "1"*, it is synchronized to ALE to output a control signal.</p>	MODE0	MODE1	External Memory	0	0	4K bytes	1	0	16K bytes	1	1	64K bytes
MODE0	MODE1	External Memory												
0	0	4K bytes												
1	0	16K bytes												
1	1	64K bytes												
NMI (Non-Maskable Interrupt)	Input	Non-maskable interrupt input pin of the edge trigger (falling edge)												
INT1 (Interrupt Request)	Input	A maskable interrupt input pin of the edge trigger (rising edge). Also, it can be used as a zero-cross detection pin for AC input.												
AN7 to AN0 (Analog Input)	Input	8 pins of analog input to A/D converter. AN7 to AN4 can be used as edge detection (falling edge) input.												
V <sub>AREF</sub> (Reference Voltage)	Input	A common pin serving both as a standard voltage input pin for A/D converter and as a control pin for A/D converter operation.												
A <sub>VDD</sub> (Analog V <sub>DD</sub> )		Power supply pin for A/D converter.												
A <sub>VSS</sub> (Analog V <sub>SS</sub> )		GND pin for A/D converter.												
X1, X2 (Crystal)		Crystal connection pins for system clock oscillation. X1 should be input when a clock is supplied from outside. Input the clock of the reverse phase of X1 to X2.												
RESET (Reset)	Input	Low-level active system reset input.												
STOP (Stop)		Control signal input pin in hardware STOP mode. The oscillation stops when a clock is supplied from outside.												
V <sub>DD</sub>		Positive power supply pin.												
V <sub>SS</sub>		GND pin.												

\* Pull-up. Pull-up resistor R is  $4 [k\Omega] \leq R \leq 0.4 t_{cyc} [k\Omega]$  ( $t_{cyc}$  is ns unit).

**Remarks** The μPD78C11A and μPD78C12A are pull-up resistor incorporation specifiable by mask option at ports A, B and C.

1.2 PIN INPUT/OUTPUT CIRCUITS

Tables 1-1 and 1-2, and figures (1) to (15) show input- output circuits of each pin in a partially simplified form.

Table 1-1 Pin Type No. (μPD78C10A)

Pin Name	Type No.	Pin Name	Type No.
PA7 to PA0	5	$\overline{\text{RESET}}$	2
PB7 to PB0	5	$\overline{\text{RD}}$	4
PC1 to PC0	5	$\overline{\text{WR}}$	4
PC2/ $\overline{\text{SCK}}$	8	ALE	4
PC3/ $\overline{\text{INT2}}$	10	$\overline{\text{STOP}}$	2
PC7 to PC4	5	MODE0	11
PD7 to PD0	5	MODE1	11
PF7 to PF0	5	AN3 to AN0	7
$\overline{\text{NMI}}$	5	AN7 to AN4	12
INT1	2	V <sub>AREF</sub>	13

Table 1-2 Pin Type No. (μPD78C11A and 78C12A)

Pin Name	Type No.	Pin Name	Type No.
PA7 to PA0	5-A	$\overline{\text{RESET}}$	2
PB7 to PB0	5-A	$\overline{\text{RD}}$	4
PC1 to PC0	5-A	$\overline{\text{WR}}$	4
PC2/ $\overline{\text{SCK}}$	8-A	ALE	4
PC3/ $\overline{\text{INT2}}$	10-A	$\overline{\text{STOP}}$	2
PC7 to PC4	5-A	MODE0	11
PD7 to PD0	5	MODE1	11
PF7 to PF0	5	AN3 to AN0	7
$\overline{\text{NMI}}$	2	AN7 to AN4	12
INT1	9	V <sub>AREF</sub>	13

(1) Type 1

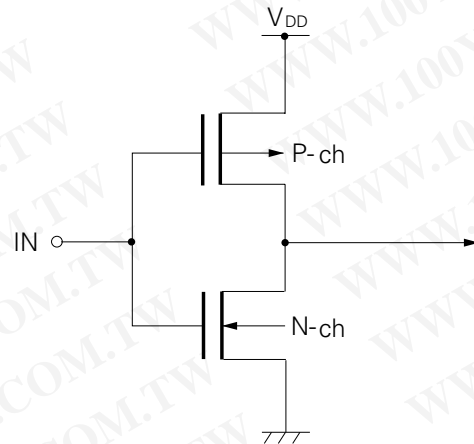

(2) Type 2

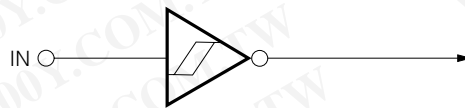

(3) Type 4

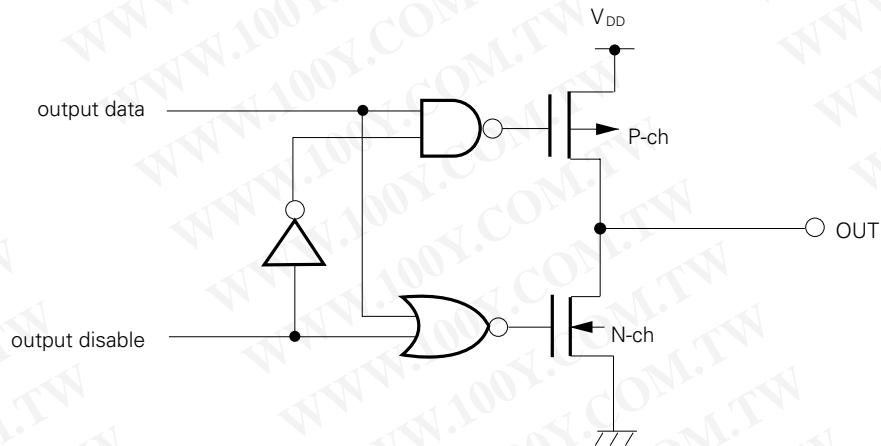

(4) Type 4-A

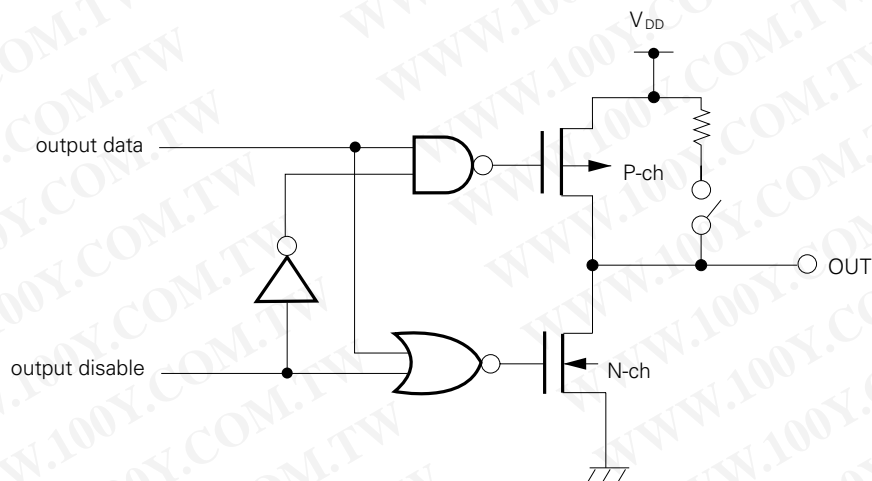

(5) Type 5

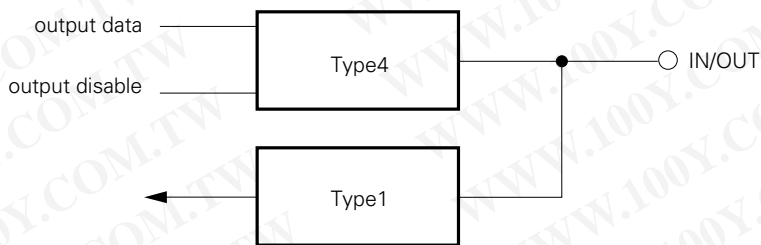

(6) Type 5-A

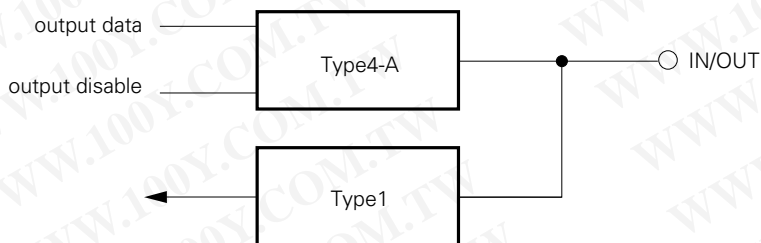

(7) Type 7

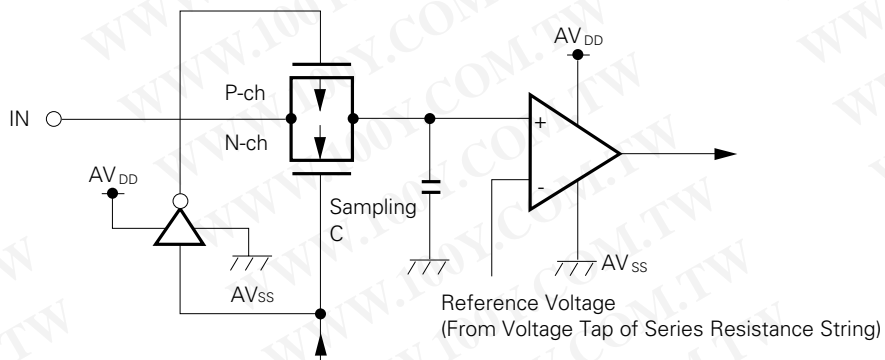

(8) Type 8

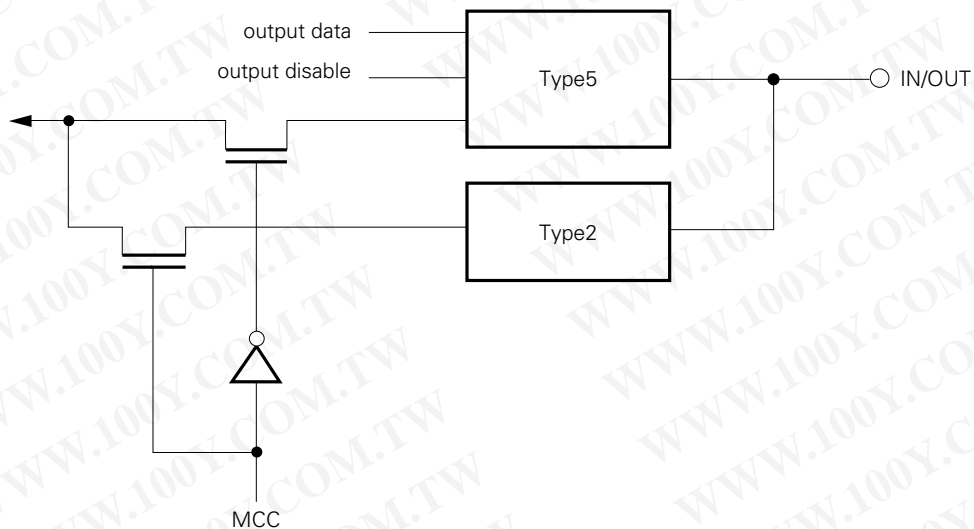

(9) Type 8-A

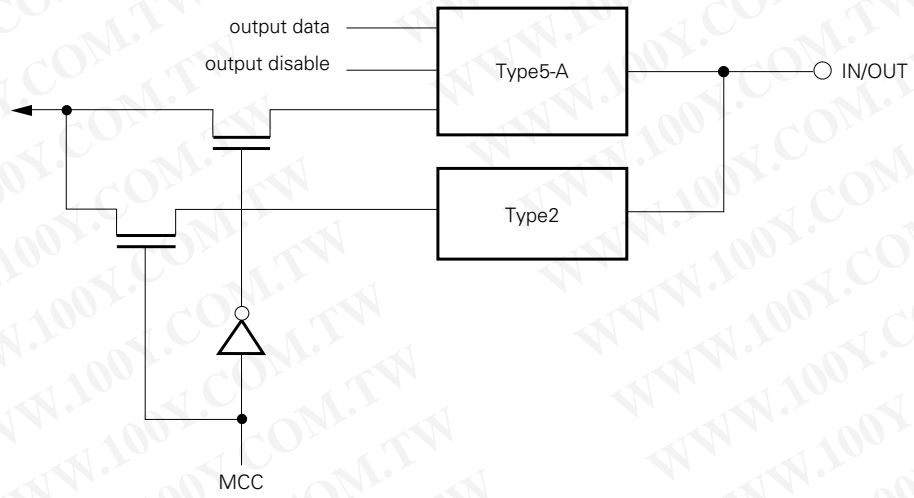

(10) Type 9

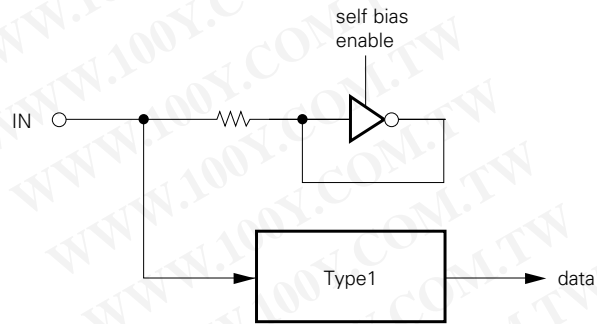

(11) Type 10

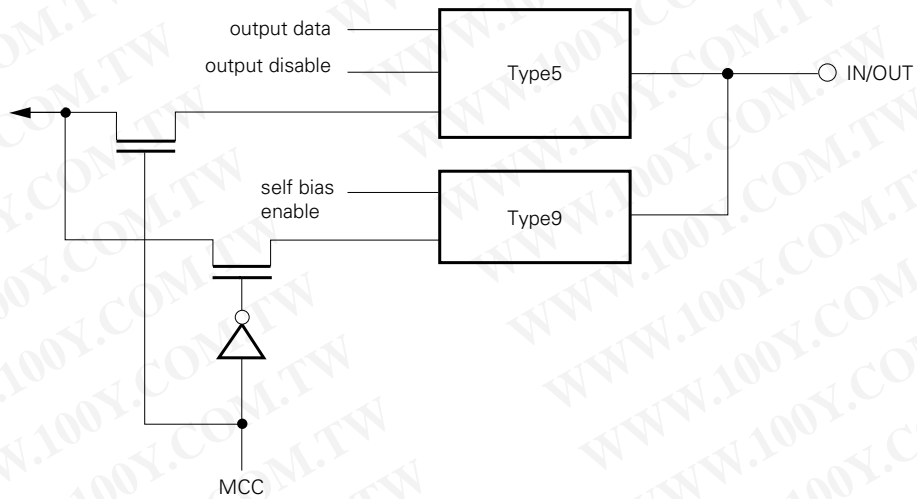

(12) Type 10-A

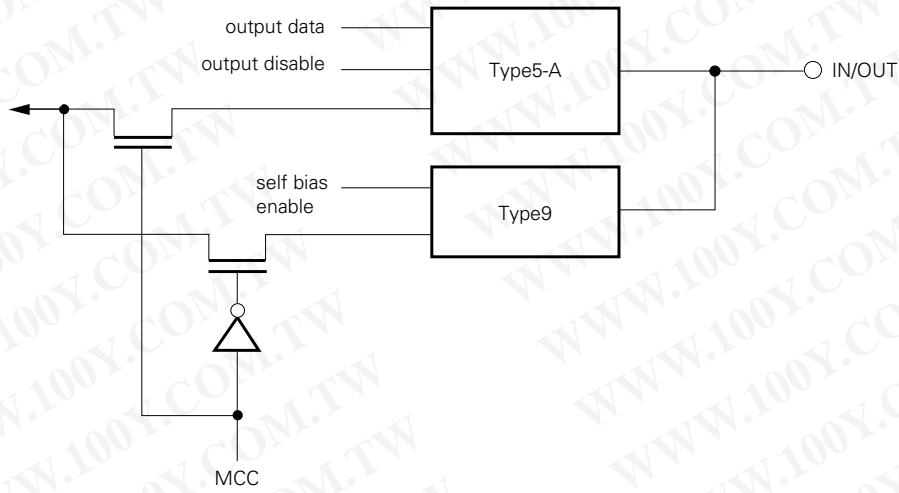

(13) Type 11

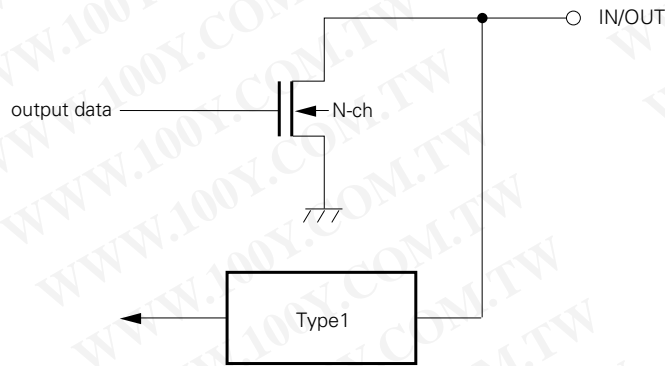

(14) Type 12

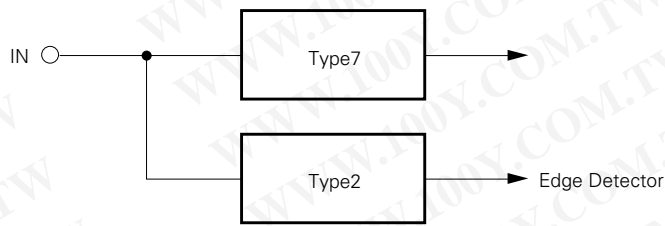

(15) Type 13

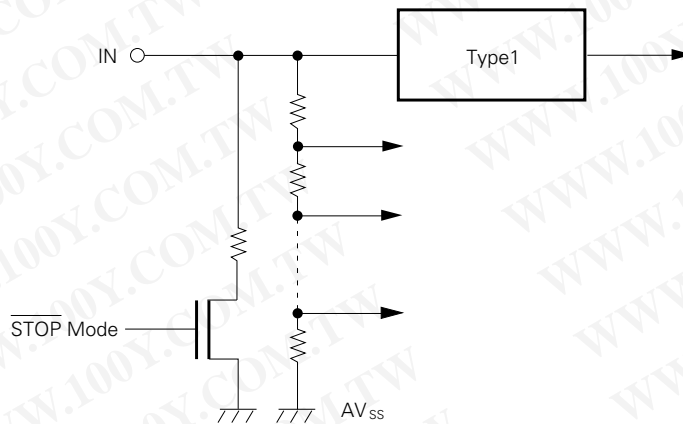

**1.3 PIN MASK OPTIONS**

μPD78C11A and 78C12A has the following mask options, which can be selected bit-wise according to the application.

Pin Name	Mask Options
PA7 to PA0	① Pull-up resistor incorporated ② Pull-up resistor not incorporated
PB7 to PB0	
PC7 to PC0	

- Cautions**
1. Zero-cross function can not be operated normally if pull-up resistor is incorporated in PC3.
  2. μPD78C10A has no mask option.

**1.4 RECOMMENDED CONNECTION OF UNUSED PINS**

Pin	Recommended Connection
PA7 to PA0	Connect to V <sub>SS</sub> or V <sub>DD</sub> via resistor
PB7 to PB0	
PC7 to PC0	
PD7 to PD0	
PF7 to PF0	
R <sub>D</sub>	Leave open
W <sub>R</sub>	
ALE	
STOP	Connect to V <sub>DD</sub>
INT1, NMI	Connect to V <sub>SS</sub> or V <sub>DD</sub>
AV <sub>DD</sub>	Connect to V <sub>DD</sub>
AV <sub>AREF</sub>	Connect to V <sub>SS</sub>
AV <sub>SS</sub>	
AN7 to AN0	Connect to AV <sub>SS</sub> or AV <sub>DD</sub>

**2. DIFFERENCES BETWEEN μPD78C10A AND μPD78C11A, 78C12A**

The difference between the μPD78C10A and μPD78C11A, 78C12A is whether or not there is an on-chip mask programmable ROM. The memory map differs accordingly as described below.

(1) μPD78C10A

Since the μPD78C10A does not have an on-chip ROM, all memory, except the on-chip RAM area (addresses FF00H to FFFFH) can be installed outside. The size of this external memory can be selected from among 4K bytes (0000H to 0FFFH), 16K bytes (0000H to 3FFFH), and 64K bytes (0000H to FEFFH) by MODE0 and MODE1 pin setting as shown in the following table and Fig. 2-1.

Operation Mode	Control Pin		External Memory	On-Chip RAM
	MODE1	MODE0		
4K bytes access	0	0	4K bytes (address 0000H to 0FFFH)	Address FF00H to FFFFH
16K bytes access	0	1	16K bytes (address 0000H to 3FFFH)	Address FF00H to FFFFH
64K bytes access	1	1	64K bytes (address 0000H to FEFFH)	Address FF00H to FFFFH

External memory is accessed by using PD7 to PD0 (multiplexed address/data bus), PF7 to PF0 (address bus), and the RD, WR, and ALE signals. When 4K-byte or 16K-byte external memory is accessed PF7 to PF0 not used as address lines can be used as general purpose input/output ports.

The size of external memory can be specified by MODE0 and MODE1 pin setting. Preset each bit of MEMORY MAPPING registers MM2, MM1, and MM0 to "0".

(2) μPD78C11A and 78C12A

The μPD78C11A has an on-chip mask programmable ROM at addresses 0000H to 0FFFH and RAM at addresses FF00H to FFFFH. Externally, memory can be extended up to 60K bytes (addresses 1000H to FEFFH) in steps. The μPD78C12A has an on-chip mask programmable ROM at address 0000H to 1FFFH and RAM at address FF00H to FFFFH. Externally, memory can be extended up to 56K bytes (address 2000H to FEFFH) in steps. The size of the external extension memory can be selected from among no external memory, 256 bytes, 4K bytes, 16K bytes, and 56K/60K bytes\* by MEMORY MAPPING register setting. External memory can be accessed by using PD7 to PD0 (multiplexed address/data bus), PF7 to PF0 (address bus), and the RD, WR, and ALE signals. Programs and data can be stored in external memory. PF7 to PF0 become address lines corresponding to the size of external memory. The remaining pins can be used as general purpose input/output ports.

PF7	PF6	PF5	PF4	PF3	PF2	PF1	PF0	External Memory
Port	Port	Port	Port	Port	Port	Port	Port	Maximum 256 bytes
Port	Port	Port	Port	AB11	AB10	AB9	AB8	Maximum 4K bytes
Port	Port	AB13	AB12	AB11	AB10	AB9	AB8	Maximum 16K bytes
AB15	AB14	AB13	AB12	AB11	AB10	AB9	AB8	Maximum 56K/60K bytes*

\* μPD78C11A: 60K bytes, μPD78C12A: 56K bytes

Fig. 2-1 μPD78C10A Memory Map

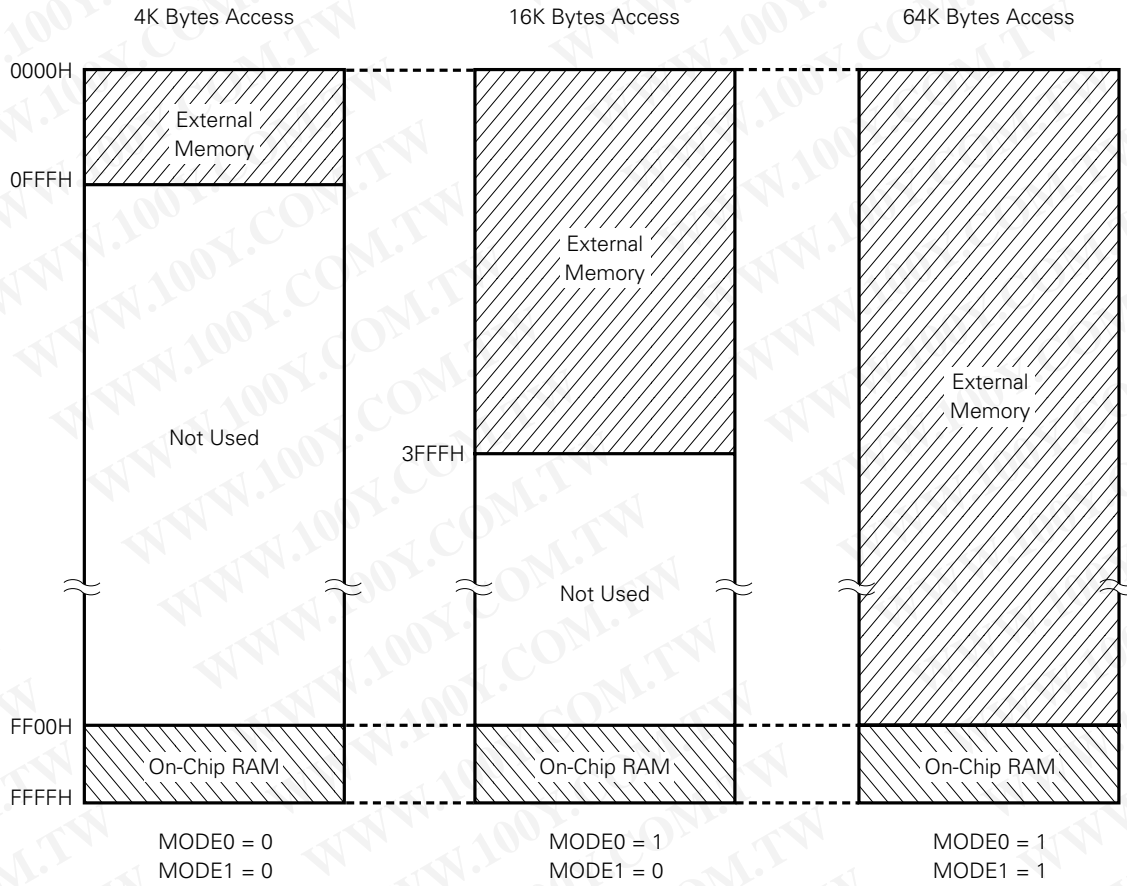

### 3. RESET OPERATIONS

When  $\overline{\text{RESET}}$  Input becomes low, the system reset is activated to create the following status.

- INTERRUPT ENABLE F/F is reset and interrupt is disabled.
- All the interrupt mask registers are set (1) and interrupt is masked.
- An interrupt request flag is reset (0) and hold interrupt is eliminated.
- Each bit of PSW is reset (0).
- 0000H is loaded into the program counter (PC).
- The MODE A, MODE B, MODE C, and MODE F registers are set to FFH and the bits (MM0, 1, and 2) of the MODE CONTROL C and MEMORY MAPPING registers are respectively reset (0), then all the ports (A, B, C, D, and F) become input port (output high-impedance).
- All the test flags but SB flag are reset (0).
- A timer mode register is set to FFH, and TIMER F/F is reset.
- The mode register (ETMM, EOM) of a timer/event counter is reset (0).
- The serial mode high register(SMH) of serial interface is reset (0), while the serial mode low register (SML) is set to 48H.
- The A/D channel mode register of the A/D converter is reset (0).
- $\overline{\text{WR}}$ ,  $\overline{\text{RD}}$ , ALE signals become high-impedance.
- The ZC1, ZC2 bits of the zero-cross mode register (ZCM) are set (1).
- The internal timing generator is initialized.
- Data memory and the following register contents are undefined:
  - Stack pointer (SP)
  - Expansion accumulator (EA, EA'), accumulator (A, A')
  - General register (B, C, D, E, H, L, B', C', D', E', H', L')
  - Output latch of each port
  - TIMER REG0, 1 (TM0, TM1)
  - TIMER/EVENT COUNTER REG0, 1 (ETM0, ETM1)
  - RAE bit of MEMORY MAPPING register
  - SB flag of test flag

When  $\overline{\text{RESET}}$  input becomes high, the reset status is released. Then, execution of the program is started from 0000H. The contents of various kinds of registers must be initialized or re-initialized in the program, if necessary.

Table 3-1 shows the state of each hardware after reset.

Table 3-2 shows the state of each pin after reset.

Table 3-1 State of Each Hardware after Reset

Hardware			State after Reset
Internal data memory	Power-on reset		Previous contents held.
	Reset input during normal operation	Writing by CPU	Undefined
		Address data other than the above	
	Operation other than writing by CPU		
Reset input in standby mode			
Expansion accumulator (EA, EA')			Undefined
Accumulator (A, A')			
General register (B, C, D, E, H, L, B', C', D', E', H', L')			
Working register vector register (V, V')			
Program counter (PC)			0000H
Stack pointer (SP)			Undefined
Port	Mode register (MA, MB, MC, MF)		FFH
	MCC register		00H
	MM register (bits MM0 to MM2)		0
Output latch of each port			Undefined
Interrupt	INTERRUPT ENABLE F/F		0
	Request flag		0
	Mask register		FFH
Test flag (except SB flag)			0
Standby flag (SB)	Power-on reset		1
	Standby mode		Previous contents held.
	Reset input during normal operation		Contents immediately before RESET input held
Timer	Timer mode register (TMM)		FFH
	Timer F/F		0
	Timer register (TM0, TM1)		Undefined
Timer/event counter	Timer/event counter mode register (ETMM)		00H
	Timer/event counter output mode register (EOM)		
	Timer/event counter register (ETM0, ETM1)		Undefined
	Timer/event counter capture register (ECPT)		
	Timer/event counter (ECNT)		
Serial interface	Serial mode high register (SMH)		00H
	Serial mode low register (SML)		48H
A/D channel mode register (ANM)			00H
MM register (MM3; RAE bit)			Undefined
Zero cross mode register (ZC1, ZC2 bits)			1

Table 3-2 State of Each Pin after Reset

Pin	State after Reset
$\overline{WR}$	High-impedance
$\overline{RD}$	
ALE	
All ports (PA, PB, PC, PD, PF)	

4. INSTRUCTION SET

4.1 IDENTIFIER/DESCRIPTION OF OPERAND

Identifier	Description
r r1 r2	V, A, B, C, D, E, H, L EAH, EAL, B, C, D, E, H, L A, B, C
sr sr1 sr2 sr3 sr4	PA, PB, PC, PD, PF, MKH, MKL, ANM, SMH, SML, EOM, ETMM, TMM, MM, MCC, MA, MB, MC, MF, TXB, TM0, TM1, ZCM PA, PB, PC, PD, PF, MKH, MKL, ANM, SMH, EOM, TMM, RXB, CR0, CR1, CR2, CR3 PA, PB, PC, PD, PF, MKH, MKL, ANM, SMH, EOM, TMM ETM0, ETM1 ECNT, ECPT
rp rp1 rp2 rp3	SP, B, D, H V, B, D, H, EA SP, B, D, H, EA B, D, H
rpa rpa1 rpa2 rpa3	B, D, H, D+, H+, D-, H- B, D, H B, D, H, D+, H+, D-, H-, D+byte, H+A, H+B, H+EA, H+byte D, H, D++, H++, D+byte, H+A, H+B, H+EA, H+byte
wa	8 bit immediate data
word byte bit	16 bit immediate data 8 bit immediate data 3 bit immediate data
f	CY, HC, Z
irf	NMI*, FT0, FT1, F1, F2, FE0, FE1, FEIN, FAD, FSR, FST, ER, OV, AN4, AN5, AN6, AN7, SB

\* NMI can also be described as FNMI.

Remarks

1. sr to sr4 (special register)

PA : PORT A	ETMM : TIMER/EVENT
PB : PORT B	COUNTER MODE
PC : PORT C	EOM : TIMER/EVENT
PD : PORT D	COUNTER OUTPUT
PF : PORT F	MODE
MA : MODE A	ANM : A/D CHANNEL MODE
MB : MODE B	CR0 : A/D CONVERSION
MC : MODE C	to RESULT 0 to 3
MCC : MODE CONTROL C	CR3
MF : MODE F	TXB : Tx BUFFER
MM : MEMORY MAPPING	RXB : Rx BUFFER
TM0 : TIMER REG0	SMH : SERIAL MODE High
TM1 : TIMER REG1	SML : SERIAL MODE Low
TMM : TIMER MODE	MKH : MASK High
ETM0 : TIMER/EVENT	MKL : MASK Low
COUNTER REG0	ZCM : ZERO CROSS MODE
ETM1 : TIMER/EVENT	
COUNTER REG1	
ECNT : TIMER/EVENT	
COUNTER UPCOUNTER	
ECPT : TIMER/EVENT	
COUNTER CAPTURE	

2. rp to rp3 (register pair)

SP : STACK POINTER
B : BC
D : DE
H : HL
V : VA
EA : EXTENDED
ACCUMULATOR

3. rpa to rpa3 (rp addressing)

B : (BC)
D : (DE)
H : (HL)
D+ : (DE)+
H+ : (HL)+
D- : (DE)-
H- : (HL)-
D++ : (DE)++
H++ : (HL)++
D + byte : (DE + byte)
H + A : (HL + A)
H + B : (HL + B)
H + EA : (HL + EA)
H + byte : (HL + byte)

4. f (flag)

CY : CARRY
HC : HALF CARRY
Z : ZERO

5. irf (interrupt flag)

NMI : NMI INPUT
FT0 : INTFT0
FT1 : INTFT1
F1 : INTF1
F2 : INTF2
FE0 : INTFE0
FE1 : INTFE1
FEIN : INTFEIN
FAD : INTFAD
FSR : INTFSR
FST : INTFST
ER : ERROR
OV : OVERFLOW
AN4 : ANALOG INPUT 4 to 7
to
AN7
SB : STANDBY

4.2 SYMBOL DESCRIPTION OF OPERATION CODE

R <sub>2</sub>	R <sub>1</sub>	R <sub>0</sub>	reg
0	0	0	V
0	0	1	A
0	1	0	B
0	1	1	C
1	0	0	D
1	0	1	E
1	1	0	H
1	1	1	L

T <sub>2</sub>	T <sub>1</sub>	T <sub>0</sub>	reg
0	0	0	EAH
0	0	1	EAL
0	1	0	B
0	1	1	C
1	0	0	D
1	0	1	E
1	1	0	H
1	1	1	L

A <sub>3</sub>	A <sub>2</sub>	A <sub>1</sub>	A <sub>0</sub>	addressing
0	0	0	0	—
0	0	0	1	(BC)
0	0	1	0	(DE)
0	0	1	1	(HL)
0	1	0	0	(DE)+
0	1	0	1	(HL)+
0	1	1	0	(DE)-
0	1	1	1	(HL)-
1	0	1	1	(DE + byte)
1	1	0	0	(HL + A)
1	1	0	1	(HL + B)
1	1	1	0	(HL + EA)
1	1	1	1	(HL + byte)

S <sub>5</sub>	S <sub>4</sub>	S <sub>3</sub>	S <sub>2</sub>	S <sub>1</sub>	S <sub>0</sub>	Special-reg
0	0	0	0	0	0	PA
0	0	0	0	0	1	PB
0	0	0	0	1	0	PC
0	0	0	0	1	1	PD
0	0	0	1	0	1	PF
0	0	0	1	1	0	MKH
0	0	0	1	1	1	MKL
0	0	1	0	0	0	ANM
0	0	1	0	0	1	SMH
0	0	1	0	1	0	SML
0	0	1	0	1	1	EOM
0	0	1	1	0	0	ETMM
0	0	1	1	0	1	TMM
0	1	0	0	0	0	MM
0	1	0	0	0	1	MCC
0	1	0	0	1	0	MA
0	1	0	0	1	1	MB
0	1	0	1	0	0	MC
0	1	0	1	1	1	MF
0	1	1	0	0	0	TXB
0	1	1	0	0	1	RXB
0	1	1	1	0	1	TM0
0	1	1	1	0	1	TM1
1	0	0	0	0	0	CR0
1	0	0	0	0	1	CR1
1	0	0	0	1	0	CR2
1	0	0	0	1	1	CR3
1	0	1	0	0	0	ZCM

C <sub>3</sub>	C <sub>2</sub>	C <sub>1</sub>	C <sub>0</sub>	addressing
0	0	1	0	(DE)
0	0	1	1	(HL)
0	1	0	0	(DE)++
0	1	0	1	(HL)++
1	0	1	1	(DE + byte)
1	1	0	0	(HL + A)
1	1	0	1	(HL + B)
1	1	1	0	(HL + EA)
1	1	1	1	(HL + byte)

I <sub>4</sub>	I <sub>3</sub>	I <sub>2</sub>	I <sub>1</sub>	I <sub>0</sub>	INTF
0	0	0	0	0	NMI
0	0	0	0	1	FT0
0	0	0	1	0	FT1
0	0	0	1	1	F1
0	0	1	0	0	F2
0	0	1	0	1	FE0
0	0	1	1	0	FE1
0	0	1	1	1	FEIN
0	1	0	0	0	FAD
0	1	0	0	1	FSR
0	1	0	1	0	FST
0	1	0	1	1	ER
0	1	1	0	0	OV
1	0	0	0	0	AN4
1	0	0	0	1	AN5
1	0	0	1	0	AN6
1	0	0	1	1	AN7
1	0	1	0	0	SB

U <sub>0</sub>	special-reg
0	ETM0
1	ETM1

V <sub>0</sub>	special-reg
0	ECNT
1	ECPT

P <sub>2</sub>	P <sub>1</sub>	P <sub>0</sub>	reg-pair
0	0	0	SP
0	0	1	BC
0	1	0	DE
0	1	1	HL
1	0	0	EA

Q <sub>2</sub>	Q <sub>1</sub>	Q <sub>0</sub>	reg-pair
0	0	0	VA
0	0	1	BC
0	1	0	DE
0	1	1	HL
1	0	0	EA

F <sub>2</sub>	F <sub>1</sub>	F <sub>0</sub>	flag
0	0	0	—
0	1	0	CY
0	1	1	HC
1	0	0	Z

#### 4.3 INSTRUCTION EXECUTION TIME

1 state shown here is composed of 3 clock cycles. When a clock cycle of 15 MHz is used, the execution time should be 200 ns ( $= 3 \times 1/15 \mu\text{s}$ ). In this case, the 4-state instruction which is the minimum execution time should be execution time of 0.8  $\mu\text{s}$ .

Note 1	Mnemonic	Operand	Operation Code				State	Operation	Skip Condition
			B1	B2	B3	B4			
8-bit data transfer instructions	MOV	r1, A	0 0 0 1 1 T <sub>2</sub> T <sub>1</sub> T <sub>0</sub>				4	r1 ← A	
		A, r1	0 0 0 0 1 T <sub>2</sub> T <sub>1</sub> T <sub>0</sub>				4	A ← r1	
		* sr, A	0 1 0 0 1 1 0 1	1 1 S <sub>5</sub> S <sub>4</sub> S <sub>3</sub> S <sub>2</sub> S <sub>1</sub> S <sub>0</sub>			10	sr ← A	
		* A, sr1	0 1 0 0 1 1 0 0	1 1 S <sub>5</sub> S <sub>4</sub> S <sub>3</sub> S <sub>2</sub> S <sub>1</sub> S <sub>0</sub>			10	A ← sr1	
		r, word	0 1 1 1 0 0 0 0	0 1 1 0 1 R <sub>2</sub> R <sub>1</sub> R <sub>0</sub>	Low Adrs	High Adrs	17	r ← (word)	
		word, r	0 1 1 1 0 0 0 0	0 1 1 1 1 R <sub>2</sub> R <sub>1</sub> R <sub>0</sub>	Low Adrs	High Adrs	17	(word) ← r	
	MVI	* r, byte	0 1 1 0 1 R <sub>2</sub> R <sub>1</sub> R <sub>0</sub>	← Data →			7	r ← byte	
		sr2, byte	0 1 1 0 0 1 0 0	S <sub>3</sub> 0 0 0 0 S <sub>2</sub> S <sub>1</sub> S <sub>0</sub>	Data		14	sr2 ← byte	
	MVIW	* wa, byte	0 1 1 1 0 0 0 1	← Offset →		Data	13	(V. wa) ← byte	
	MVIX	* rpa1, byte	0 1 0 0 1 0 A <sub>1</sub> A <sub>0</sub>	← Data →			10	(rpa1) ← byte	
	STAW	* wa	0 1 1 0 0 0 1 1	← Offset →			10	(V. wa) ← A	
	LDAW	* wa	0 0 0 0 0 0 0 1	← Offset →			10	A ← (V. wa)	
	STAX	* rpa2	A <sub>3</sub> 0 1 1 1 A <sub>2</sub> A <sub>1</sub> A <sub>0</sub>	Data*1			7/13*3	(rpa2) ← A	
	LDAX	* rpa2	A <sub>3</sub> 0 1 0 1 A <sub>2</sub> A <sub>1</sub> A <sub>0</sub>	Data*1			7/13*3	A ← (rpa2)	
	EXX		0 0 0 1 0 0 0 1				4	{ B ↔ B', C ↔ C', D ↔ D' E ↔ E', H ↔ H', L ↔ L'	
	EXA		0 0 0 1 0 0 0 0				4	V, A ↔ V', A', EA ↔ EA'	
EXH		0 1 0 1 0 0 0 0				4	H, L ↔ H', L'		
BLOCK		0 0 1 1 0 0 0 1				13 (C + 1)	(DE)* ← (HL)*, C ← C - 1 End if borrow		
Note 2	DMOV	rp3, EA	1 0 1 1 0 1 P <sub>1</sub> P <sub>0</sub>			4	rp3 <sub>L</sub> ← EAL, rp3 <sub>H</sub> ← EAH		
		EA, rp3	1 0 1 0 0 1 P <sub>1</sub> P <sub>0</sub>			4	EAL ← rp3 <sub>L</sub> , EAH ← rp3 <sub>H</sub>		

- Note**
1. Instruction Group
  2. 16-bit data transfer instructions

Note 1	Mnemonic	Operand	Operation Code				State	Operation	Skip Condition
			B1	B2	B3	B4			
16-bit data transfer instructions	DMOV	sr3, EA	0 1 0 0 1 0 0 0	1 1 0 1 0 0 1 U <sub>0</sub>			14	sr3 ← EA	
		EA, sr4		1 1 0 0 0 0 0 V <sub>0</sub>			14	EA ← sr4	
	SBCD	word	0 1 1 1 0 0 0 0	0 0 0 1 1 1 1 0	Low Adrs	High Adrs	20	(word) ← C, (word + 1) ← B	
	SDED	word		0 0 1 0 1 1 1 0			20	(word) ← E, (word + 1) ← D	
	SHLD	word		0 0 1 1 1 1 1 0			20	(word) ← L, (word + 1) ← H	
	SSPD	word		0 0 0 0 1 1 1 0			20	(word) ← SP <sub>L</sub> , (word + 1) ← SP <sub>H</sub>	
	STEAX	rpa3	0 1 0 0 1 0 0 0	1 0 0 1 C <sub>3</sub> C <sub>2</sub> C <sub>1</sub> C <sub>0</sub>	Data*2		14/20 <sup>*3</sup>	(rpa3) ← EAL, (rpa3 + 1) ← EAH	
	LBCD	word	0 1 1 1 0 0 0 0	0 0 0 1 1 1 1 1	Low Adrs	High Adrs	20	C ← (word), B ← (word + 1)	
	LDED	word		0 0 1 0 1 1 1 1			20	E ← (word), D ← (word + 1)	
	LHLD	word		0 0 1 1 1 1 1 1			20	L ← (word), H ← (word + 1)	
	LSPD	word		0 0 0 0 1 1 1 1			20	SP <sub>L</sub> ← (word), SP <sub>H</sub> ← (word + 1)	
	LDEAX	rpa3	0 1 0 0 1 0 0 0	1 0 0 0 C <sub>3</sub> C <sub>2</sub> C <sub>1</sub> C <sub>0</sub>	Data*2		14/20 <sup>*3</sup>	EAL ← (rpa3), EAH ← (rpa3 + 1)	
	PUSH	rp1	1 0 1 1 0 Q <sub>2</sub> Q <sub>1</sub> Q <sub>0</sub>				13	(SP - 1) ← rp1 <sub>H</sub> , (SP - 2) ← rp1 <sub>L</sub> SP ← SP - 2	
	POP	rp1	1 0 1 0 0 Q <sub>2</sub> Q <sub>1</sub> Q <sub>0</sub>				10	rp1 <sub>L</sub> ← (SP), rp1 <sub>H</sub> ← (SP + 1) SP ← SP + 2	
	LXI *	rp2, word	0 P <sub>2</sub> P <sub>1</sub> P <sub>0</sub> 0 1 0 0	← Low Byte →	High Byte		10	rp2 ← word	
TABLE		0 1 0 0 1 0 0 0	1 0 1 0 1 0 0 0			17	C ← (PC + 3 + A) B ← (PC + 3 + A + 1)		
Note 2	ADD	A, r	0 1 1 0 0 0 0 0	1 1 0 0 0 R <sub>2</sub> R <sub>1</sub> R <sub>0</sub>			8	A ← A + r	
		r, A		0 1 0 0			8	r ← r + A	
	ADC	A, r		1 1 0 1			8	A ← A + r + CY	
		r, A		0 1 0 1			8	r ← r + A + CY	

- Note**
1. Instruction Group
  2. 8-bit operation instructions (register)

Note	Mnemonic	Operand	Operation Code				State	Operation	Skip Condition
			B1	B2	B3	B4			
8-bit operation instructions (register)	ADDNC	A, r	0 1 1 0 0 0 0 0	1 0 1 0 0 R <sub>2</sub> R <sub>1</sub> R <sub>0</sub>			8	$A \leftarrow A + r$	No Carry
		r, A		0 0 1 0			8	$r \leftarrow r + A$	No Carry
	SUB	A, r		1 1 1 0			8	$A \leftarrow A - r$	
		r, A		0 1 1 0			8	$r \leftarrow r - A$	
	SBB	A, r		1 1 1 1			8	$A \leftarrow A - r - CY$	
		r, A		0 1 1 1			8	$r \leftarrow r - A - CY$	
	SUBNB	A, r		1 0 1 1			8	$A \leftarrow A - r$	No Borrow
		r, A		0 0 1 1			8	$r \leftarrow r - A$	No Borrow
	ANA	A, r		1 0 0 0 1 R <sub>2</sub> R <sub>1</sub> R <sub>0</sub>			8	$A \leftarrow A \wedge r$	
		r, A		0 0 0 0			8	$r \leftarrow r \wedge A$	
	ORA	A, r		1 0 0 1			8	$A \leftarrow A \vee r$	
		r, A		0 0 0 1			8	$r \leftarrow r \vee A$	
	XRA	A, r		1 0 0 1 0 R <sub>2</sub> R <sub>1</sub> R <sub>0</sub>			8	$A \leftarrow A \nabla r$	
		r, A		0 0 0 1			8	$r \leftarrow r \nabla A$	
	GTA	A, r		1 0 1 0 1 R <sub>2</sub> R <sub>1</sub> R <sub>0</sub>			8	$A - r - 1$	No Borrow
		r, A		0 0 1 0			8	$r - A - 1$	No Borrow
	LTA	A, r		1 0 1 1			8	$A - r$	Borrow
		r, A		0 0 1 1			8	$r - A$	Borrow
NEA	A, r		1 1 1 0			8	$A - r$	No Zero	
	r, A		0 1 1 0			8	$r - A$	No Zero	

Note Instruction Group

Note	Mnemonic	Operand	Operation Code				State	Operation	Skip Condition
			B1	B2	B3	B4			
8-bit operation instructions (register)	EQA	A, r	0 1 1 0 0 0 0 0	1 1 1 1 1 R <sub>2</sub> R <sub>1</sub> R <sub>0</sub>			8	$A - r$	Zero
		r, A		0 1 1 1			8	$r - A$	Zero
	ONA	A, r		1 1 0 0			8	$A \wedge r$	No Zero
	OFFA	A, r		1 1 0 1			8	$A \wedge r$	Zero
8-bit operation instructions (memory)	ADDX	rpa	0 1 1 1 0 0 0 0	1 1 0 0 0 0 A <sub>2</sub> A <sub>1</sub> A <sub>0</sub>			11	$A \leftarrow A + (rpa)$	
	ADCX	rpa		1 1 0 1			11	$A \leftarrow A + (rpa) + CY$	
	ADDNCX	rpa		1 0 1 0			11	$A \leftarrow A + (rpa)$	No Carry
	SUBX	rpa		1 1 1 0			11	$A \leftarrow A - (rpa)$	
	SBBX	rpa		1 1 1 1			11	$A \leftarrow A - (rpa) - CY$	
	SUBNBX	rpa		1 0 1 1			11	$A \leftarrow A - (rpa)$	No Borrow
	ANAX	rpa		1 0 0 0 1 A <sub>2</sub> A <sub>1</sub> A <sub>0</sub>			11	$A \leftarrow A \wedge (rpa)$	
	ORAX	rpa		1 0 0 1			11	$A \leftarrow A \vee (rpa)$	
	XRAX	rpa		1 0 0 1 0 A <sub>2</sub> A <sub>1</sub> A <sub>0</sub>			11	$A \leftarrow A \nabla (rpa)$	
	GTAX	rpa		1 0 1 0 1 A <sub>2</sub> A <sub>1</sub> A <sub>0</sub>			11	$A - (rpa) - 1$	No Borrow
	LTAX	rpa		1 0 1 1			11	$A - (rpa)$	Borrow
	NEAX	rpa		1 1 1 0			11	$A - (rpa)$	No Zero
	EQAX	rpa		1 1 1 1			11	$A - (rpa)$	Zero
	ONAX	rpa		1 1 0 0			11	$A \wedge (rpa)$	No Zero
OFFAX	rpa		1 1 0 1			11	$A \wedge (rpa)$	Zero	

**Note** Instruction Group

Note	Mnemonic	Operand	Operation Code				State	Operation	Skip Condition
			B1	B2	B3	B4			
Immediate data operation instructions	ADI	* A, byte	0 1 0 0 0 1 1 0	← Data →			7	$A \leftarrow A + \text{byte}$	
		r, byte	0 1 1 1 0 1 0 0	0 1 0 0 0 R <sub>2</sub> R <sub>1</sub> R <sub>0</sub>	Data		11	$r \leftarrow r + \text{byte}$	
		sr2, byte	0 1 1 0	S <sub>3</sub> 1 0 0 0 S <sub>2</sub> S <sub>1</sub> S <sub>0</sub>			20	$sr2 \leftarrow sr2 + \text{byte}$	
	ACI	* A, byte	0 1 0 1 0 1 1 0	← Data →			7	$A \leftarrow A + \text{byte} + CY$	
		r, byte	0 1 1 1 0 1 0 0	0 1 0 1 0 R <sub>2</sub> R <sub>1</sub> R <sub>0</sub>	Data		11	$r \leftarrow r + \text{byte} + CY$	
		sr2, byte	0 1 1 0	S <sub>3</sub> 1 0 1 0 S <sub>2</sub> S <sub>1</sub> S <sub>0</sub>			20	$sr2 \leftarrow sr2 + \text{byte} + CY$	
	ADINC	* A, byte	0 0 1 0 0 1 1 0	← Data →			7	$A \leftarrow A + \text{byte}$	No Carry
		r, byte	0 1 1 1 0 1 0 0	0 0 1 0 0 R <sub>2</sub> R <sub>1</sub> R <sub>0</sub>	Data		11	$r \leftarrow r + \text{byte}$	No Carry
		sr2, byte	0 1 1 0	S <sub>3</sub> 0 1 0 0 S <sub>2</sub> S <sub>1</sub> S <sub>0</sub>			20	$sr2 \leftarrow sr2 + \text{byte}$	No Carry
	SUI	* A, byte	0 1 1 0 0 1 1 0	← Data →			7	$A \leftarrow A - \text{byte}$	
		r, byte	0 1 1 1 0 1 0 0	0 1 1 0 0 R <sub>2</sub> R <sub>1</sub> R <sub>0</sub>	Data		11	$r \leftarrow r - \text{byte}$	
		sr2, byte	0 1 1 0	S <sub>3</sub> 1 1 0 0 S <sub>2</sub> S <sub>1</sub> S <sub>0</sub>			20	$sr2 \leftarrow sr2 - \text{byte}$	
	SBI	* A, byte	0 1 1 1 0 1 1 0	← Data →			7	$A \leftarrow A - \text{byte} - CY$	
		r, byte	0 1 1 1 0 1 0 0	0 1 1 1 0 R <sub>2</sub> R <sub>1</sub> R <sub>0</sub>	Data		11	$r \leftarrow r - \text{byte} - CY$	
		sr2, byte	0 1 1 0	S <sub>3</sub> 1 1 1 0 S <sub>2</sub> S <sub>1</sub> S <sub>0</sub>			20	$sr2 \leftarrow sr2 - \text{byte} - CY$	
SUI NB	* A, byte	0 0 1 1 0 1 1 0	← Data →			7	$A \leftarrow A - \text{byte}$	No Borrow	
	r, byte	0 1 1 1 0 1 0 0	0 0 1 1 0 R <sub>2</sub> R <sub>1</sub> R <sub>0</sub>	Data		11	$r \leftarrow r - \text{byte}$	No Borrow	
	sr2, byte	0 1 1 0	S <sub>3</sub> 0 1 1 0 S <sub>2</sub> S <sub>1</sub> S <sub>0</sub>			20	$sr2 \leftarrow sr2 - \text{byte}$	No Borrow	
ANI	* A, byte	0 0 0 0 0 1 1 1	← Data →			7	$A \leftarrow A \wedge \text{byte}$		
	r, byte	0 1 1 1 0 1 0 0	0 0 0 0 1 R <sub>2</sub> R <sub>1</sub> R <sub>0</sub>	Data		11	$r \leftarrow r \wedge \text{byte}$		

Note Instruction Group

Note	Mnemonic	Operand	Operation Code				State	Operation	Skip Condition
			B1	B2	B3	B4			
Immediate data operation instructions	ANI	sr2, byte	0 1 1 0 0 1 0 0	S <sub>3</sub> 0 0 0 1 S <sub>2</sub> S <sub>1</sub> S <sub>0</sub>	Data		20	sr2 ← sr2 ∧ byte	
	*	A, byte	0 0 0 1 0 1 1 1	← Data →			7	A ← A ∨ byte	
	ORI	r, byte	0 1 1 1 0 1 0 0	0 0 0 1 1 R <sub>2</sub> R <sub>1</sub> R <sub>0</sub>	Data		11	r ← r ∨ byte	
		sr2, byte	0 1 1 0	S <sub>3</sub> 0 0 1 1 S <sub>2</sub> S <sub>1</sub> S <sub>0</sub>			20	sr2 ← sr2 ∨ byte	
	*	A, byte	0 0 0 1 0 1 1 0	← Data →			7	A ← A ∨ byte	
	XRI	r, byte	0 1 1 1 0 1 0 0	0 0 0 1 0 R <sub>2</sub> R <sub>1</sub> R <sub>0</sub>	Data		11	r ← r ∨ byte	
		sr2, byte	0 1 1 0	S <sub>3</sub> 0 0 1 0 S <sub>2</sub> S <sub>1</sub> S <sub>0</sub>			20	sr2 ← sr2 ∨ byte	
	*	A, byte	0 0 1 0 0 1 1 1	← Data →			7	A – byte – 1	No Borrow
	GTI	r, byte	0 1 1 1 0 1 0 0	0 0 1 0 1 R <sub>2</sub> R <sub>1</sub> R <sub>0</sub>	Data		11	r – byte – 1	No Borrow
		sr2, byte	0 1 1 0	S <sub>3</sub> 0 1 0 1 S <sub>2</sub> S <sub>1</sub> S <sub>0</sub>			14	sr2 – byte – 1	No Borrow
	*	A, byte	0 0 1 1 0 1 1 1	← Data →			7	A – byte	Borrow
	LTI	r, byte	0 1 1 1 0 1 0 0	0 0 1 1 1 R <sub>2</sub> R <sub>1</sub> R <sub>0</sub>	Data		11	r – byte	Borrow
		sr2, byte	0 1 1 0	S <sub>3</sub> 0 1 1 1 S <sub>2</sub> S <sub>1</sub> S <sub>0</sub>			14	sr2 – byte	Borrow
	*	A, byte	0 1 1 0 0 1 1 1	← Data →			7	A – byte	No Zero
	NEI	r, byte	0 1 1 1 0 1 0 0	0 1 1 0 1 R <sub>2</sub> R <sub>1</sub> R <sub>0</sub>	Data		11	r – byte	No Zero
		sr2, byte	0 1 1 0	S <sub>3</sub> 1 1 0 1 S <sub>2</sub> S <sub>1</sub> S <sub>0</sub>			14	sr2 – byte	No Zero
	*	A, byte	0 1 1 1 0 1 1 1	← Data →			7	A – byte	Zero
	EQI	r, byte	0 1 1 1 0 1 0 0	0 1 1 1 1 R <sub>2</sub> R <sub>1</sub> R <sub>0</sub>	Data		11	r – byte	Zero
sr2, byte		0 1 1 0	S <sub>3</sub> 1 1 1 1 S <sub>2</sub> S <sub>1</sub> S <sub>0</sub>			14	sr2 – byte	Zero	

Note Instruction Group

Note	Mnemonic	Operand	Operation Code				State	Operation	Skip Condition
			B1	B2	B3	B4			
Immediate data operation instructions	* ONI	A, byte	0 1 0 0 0 1 1 1	← Data →			7	$A \wedge \text{byte}$	No Zero
		r, byte	0 1 1 1 0 1 0 0	0 1 0 0 1 R <sub>2</sub> R <sub>1</sub> R <sub>0</sub>	Data		11	$r \wedge \text{byte}$	No Zero
		sr2, byte	0 1 1 0	S <sub>3</sub> 1 0 0 1 S <sub>2</sub> S <sub>1</sub> S <sub>0</sub>			14	$sr2 \wedge \text{byte}$	No Zero
	* OFFI	A, byte	0 1 0 1 0 1 1 1	← Data →			7	$A \wedge \text{byte}$	Zero
		r, byte	0 1 1 1 0 1 0 0	0 1 0 1 1 R <sub>2</sub> R <sub>1</sub> R <sub>0</sub>	Data		11	$r \wedge \text{byte}$	Zero
		sr2, byte	0 1 1 0	S <sub>3</sub> 1 0 1 1 S <sub>2</sub> S <sub>1</sub> S <sub>0</sub>			14	$sr2 \wedge \text{byte}$	Zero
Working register operation instructions	ADDW	wa	0 1 1 1 0 1 0 0	1 1 0 0 0 0 0 0	offset		14	$A \leftarrow A + (V. wa)$	
	ADCW	wa		1 1 0 1			14	$A \leftarrow A + (V. wa) + CY$	
	ADDNCW	wa		1 0 1 0			14	$A \leftarrow A + (V. wa)$	No Carry
	SUBW	wa		1 1 1 0			14	$A \leftarrow A - (V. wa)$	
	SBBW	wa		1 1 1 1			14	$A \leftarrow A - (V. wa) - CY$	
	SUBNBW	wa		1 0 1 1			14	$A \leftarrow A - (V. wa)$	No Borrow
	ANAW	wa		1 0 0 0 1 0 0 0			14	$A \leftarrow A \wedge (V. wa)$	
	ORAW	wa		1 0 0 1			14	$A \leftarrow A \vee (V. wa)$	
	XRAW	wa		1 0 0 1 0 0 0 0			14	$A \leftarrow A \nabla (V. wa)$	
	GTAW	wa		1 0 1 0 1 0 0 0			14	$A - (V. wa) - 1$	No Borrow
	LTAW	wa		1 0 1 1			14	$A - (V. wa)$	Borrow
	NEAW	wa		1 1 1 0			14	$A - (V. wa)$	No Zero
	EQAW	wa		1 1 1 1			14	$A - (V. wa)$	Zero
ONAW	wa		1 1 0 0			14	$A \wedge (V. wa)$	No Zero	

Note Instruction Group

Note	Mnemonic	Operand	Operation Code				State	Operation	Skip Condition	
			B1	B2	B3	B4				
Working register operation instructions	OFFAW	wa	0 1 1 1 0 1 0 0	1 1 0 1 1 0 0 0	Offset		14	$A \wedge (V. wa)$	Zero	
	ANIW *	wa, byte	0 0 0 0 0 1 0 1	← Offset →		Data	19	$(V. wa) \leftarrow (V. wa) \wedge \text{byte}$		
	ORIW *	wa, byte	0 0 0 1				19	$(V. wa) \leftarrow (V. wa) \vee \text{byte}$		
	GTIW *	wa, byte	0 0 1 0				13	$(V. wa) - \text{byte} - 1$	No Borrow	
	LTIW *	wa, byte	0 0 1 1				13	$(V. wa) - \text{byte}$	Borrow	
	NEIW *	wa, byte	0 1 1 0				13	$(V. wa) - \text{byte}$	No Zero	
	EQIW *	wa, byte	0 1 1 1				13	$(V. wa) - \text{byte}$	Zero	
	ONIW *	wa, byte	0 1 0 0				13	$(V. wa) \wedge \text{byte}$	No Zero	
	OFFIW	wa, byte	0 1 0 1				13	$(V. wa) \wedge \text{byte}$	Zero	
16-bit operation instructions	EADD	EA, r2	0 1 1 1 0 0 0 0	0 1 0 0 0 0	$R_1 R_0$		11	$EA \leftarrow EA + r2$		
	DADD	EA, rp3		0 1 0 0	1 1 0 0 0 1	$P_1 P_0$		11	$EA \leftarrow EA + rp3$	
	DADC	EA, rp3			1 1 0 1			11	$EA \leftarrow EA + rp3 + CY$	
	DADDNC	EA, rp3			1 0 1 0			11	$EA \leftarrow EA + rp3$	No Carry
	ESUB	EA, r2		0 0 0 0	0 1 1 0 0 0	$R_1 R_0$		11	$EA \leftarrow EA - r2$	
	DSUB	EA, rp3		0 1 0 0	1 1 1 0 0 1	$P_1 P_0$		11	$EA \leftarrow EA - rp3$	
	DSBB	EA, rp3			1 1 1 1			11	$EA \leftarrow EA - rp3 - CY$	
	DSUBNB	EA, rp3			1 0 1 1			11	$EA \leftarrow EA - rp3$	No Borrow
	DAN	EA, rp3			1 0 0 0 1 1	$P_1 P_0$		11	$EA \leftarrow EA \wedge rp3$	
	DOR	EA, rp3			1 0 0 1			11	$EA \leftarrow EA \vee rp3$	
DXR	EA, rp3			1 0 0 1 0 1	$P_1 P_0$		11	$EA \leftarrow EA \nabla rp3$		

Note Instruction Group

Note 1	Mnemonic	Operand	Operation Code				State	Operation	Skip Condition
			B1	B2	B3	B4			
Note 1 16-bit operation instructions	DGT	EA, rp3	0 1 1 1 0 1 0 0	1 0 1 0 1 1 P <sub>1</sub> P <sub>0</sub>			11	EA – rp3 – 1	No Borrow
	DLT	EA, rp3		1 0 1 1			11	EA – rp3	Borrow
	DNE	EA, rp3		1 1 1 0			11	EA – rp3	No Zero
	DEQ	EA, rp3		1 1 1 1			11	EA – rp3	Zero
	DON	EA, rp3		1 1 0 0			11	EA ∧ rp3	No Zero
	DOFF	EA, rp3		1 1 0 1			11	EA ∧ rp3	Zero
Note 2	MUL	r2	0 1 0 0 1 0 0 0	0 0 1 0 1 1 R <sub>1</sub> R <sub>0</sub>			32	EA ← A × r2	
	DIV	r2		0 0 1 1			59	EA ← EA ÷ r2, r2 ← Remainder	
Increment/decrement instructions	INR	r2	0 1 0 0 0 0 R <sub>1</sub> R <sub>0</sub>				4	r2 ← r2 + 1	Carry
	INRW *	wa	0 0 1 0 0 0 0 0	← Offset →			16	(V. wa) ← (V. wa) + 1	Carry
	INX	rp	0 0 P <sub>1</sub> P <sub>0</sub> 0 0 1 0				7	rp ← rp + 1	
		EA	1 0 1 0 1 0 0 0				7	EA ← EA + 1	
	DCR	r2	0 1 0 1 0 0 R <sub>1</sub> R <sub>0</sub>				4	r2 ← r2 – 1	Borrow
	DCRW *	wa	0 0 1 1 0 0 0 0	← Offset →			16	(V. wa) ← (V. wa) – 1	Borrow
DCX	rp	0 0 P <sub>1</sub> P <sub>0</sub> 0 0 1 1				7	rp ← rp – 1		
	EA	1 0 1 0 1 0 0 1				7	EA ← EA – 1		
Note 3	DAA		0 1 1 0 0 0 0 1				4	Decimal Adjust Accumulator	
	STC		0 1 0 0 1 0 0 0	0 0 1 0 1 0 1 1			8	CY ← 1	
	CLC			0 0 1 0 1 0 1 0			8	CY ← 0	
	NEGA			0 0 1 1 1 0 1 0			8	A ← $\bar{A}$ + 1	

- Note**
1. Instruction Group
  2. Multiplication/division instructions
  3. Other operation instructions

Note	Mnemonic	Operand	Operation Code				State	Operation	Skip Condition
			B1	B2	B3	B4			
Rotation/shift instructions	RLD		0 1 0 0 1 0 0 0	0 0 1 1 1 0 0 0			17	Rotate Left Digit	
	RRD			1 0 0 1			17	Rotate Right Digit	
	RLL	r2		0 1 R <sub>1</sub> R <sub>0</sub>			8	$r_{2m+1} \leftarrow r_{2m}, r_{20} \leftarrow CY, CY \leftarrow r_{27}$	
	RLR	r2		0 0 R <sub>1</sub> R <sub>0</sub>			8	$r_{2m-1} \leftarrow r_{2m}, r_{27} \leftarrow CY, CY \leftarrow r_{20}$	
	SLL	r2		0 0 1 0 0 1 R <sub>1</sub> R <sub>0</sub>			8	$r_{2m+1} \leftarrow r_{2m}, r_{20} \leftarrow 0, CY \leftarrow r_{27}$	
	SLR	r2		0 0 R <sub>1</sub> R <sub>0</sub>			8	$r_{2m-1} \leftarrow r_{2m}, r_{27} \leftarrow 0, CY \leftarrow r_{20}$	
	SLLC	r2		0 0 0 0 0 1 R <sub>1</sub> R <sub>0</sub>			8	$r_{2m+1} \leftarrow r_{2m}, r_{20} \leftarrow 0, CY \leftarrow r_{27}$	Carry
	SLRC	r2		0 0 R <sub>1</sub> R <sub>0</sub>			8	$r_{2m-1} \leftarrow r_{2m}, r_{27} \leftarrow 0, CY \leftarrow r_{20}$	Carry
	DRLL	EA		1 0 1 1 0 1 0 0			8	$EA_{n+1} \leftarrow EA_n, EA_0 \leftarrow CY, CY \leftarrow EA_{15}$	
	DRLR	EA		0 0 0 0			8	$EA_{n-1} \leftarrow EA_n, EA_{15} \leftarrow CY, CY \leftarrow EA_0$	
	DSLL	EA		1 0 1 0 0 1 0 0			8	$EA_{n+1} \leftarrow EA_n, EA_0 \leftarrow 0, CY \leftarrow EA_{15}$	
	DSLRL	EA		0 0 0 0			8	$EA_{n-1} \leftarrow EA_n, EA_{15} \leftarrow 0, CY \leftarrow EA_0$	
Jump instructions	JMP *	word	0 1 0 1 0 1 0 0	← Low Adrs →	High Adrs		10	PC ← word	
	JB		0 0 1 0 0 0 0 1				4	PC <sub>H</sub> ← B, PC <sub>L</sub> ← C	
	JR	word	1 1 ← jdisp 1 →				10	PC ← PC + 1 + jdisp 1	
	JRE *	word	0 1 0 0 1 1 1 ← jdisp →				10	PC ← PC + 2 + jdisp	
	JEA		0 1 0 0 1 0 0 0	0 0 1 0 1 0 0 0			8	PC ← EA	
Call Instructions	CALL *	word	0 1 0 0 0 0 0 0	← Low Adrs →	High Adrs		16	$(SP - 1) \leftarrow (PC + 3)_H, (SP - 2) \leftarrow (PC + 3)_L$ PC ← word, SP ← SP - 2	
	CALB		0 1 0 0 1 0 0 0	0 0 1 0 1 0 0 1			17	$(SP - 1) \leftarrow (PC + 2)_H, (SP - 2) \leftarrow (PC + 2)_L$ PC <sub>H</sub> ← B, PC <sub>L</sub> ← C, SP ← SP - 2	
	CALF *	word	0 1 1 1 1 ← fa →				13	$(SP - 1) \leftarrow (PC + 2)_H, (SP - 2) \leftarrow (PC + 2)_L$ PC <sub>15-11</sub> ← 00001, PC <sub>10-0</sub> ← fa, SP ← SP - 2	

Note Instruction Group

Note 1	Mnemonic	Operand	Operation Code				State	Operation	Skip Condition
			B1	B2	B3	B4			
Note 2	CALT	word	1 0 0 ← ta →				16	$(SP - 1) \leftarrow (PC + 1)_H, (SP - 2) \leftarrow (PC + 1)_L$ $PC_L \leftarrow (128 + 2ta), PC_H \leftarrow (129 + 2ta), SP \leftarrow SP - 2$	
	SOFTI		0 1 1 1 0 0 1 0				16	$(SP - 1) \leftarrow PSW, (SP - 2) \leftarrow (PC + 1)_H, (SP - 3) \leftarrow (PC + 1)_L, PC \leftarrow 0060H, SP \leftarrow SP - 3$	
Return instructions	RET		1 0 1 1 1 0 0 0				10	$PC_L \leftarrow (SP), PC_H \leftarrow (SP + 1)$ $SP \leftarrow SP + 2$	
	RETS		↓ 1 0 0 1				10	$PC_L \leftarrow (SP), PC_H \leftarrow (SP + 1), SP \leftarrow SP + 2$ $PC \leftarrow PC + n$	Unconditional skip
	RETI		0 1 1 0 0 0 1 0				13	$PC_L \leftarrow (SP), PC_H \leftarrow (SP + 1)$ $PSW \leftarrow (SP + 2), SP \leftarrow SP + 3$	
Skip instructions	BIT *	bit, wa	0 1 0 1 1 B <sub>2</sub> B <sub>1</sub> B <sub>0</sub> ← Offset →				10	Skip if (V. wa) bit = 1	(V. wa)bit = 1
	SK	f	0 1 0 0 1 0 0 0	0 0 0 0 1 F <sub>2</sub> F <sub>1</sub> F <sub>0</sub>			8	Skip if f = 1	f = 1
	SKN	f		0 0 0 1 ↓			8	Skip if f = 0	f = 0
	SKIT	irf		0 1 0 I <sub>4</sub> I <sub>3</sub> I <sub>2</sub> I <sub>1</sub> I <sub>0</sub>			8	Skip if irf = 1, then reset irf	irf = 1
	SKNIT	irf		0 1 1 I <sub>4</sub> I <sub>3</sub> I <sub>2</sub> I <sub>1</sub> I <sub>0</sub>			8	Skip if irf = 0 Reset irf, if irf = 1	irf = 0
CPU control instructions	NOP		0 0 0 0 0 0 0 0				4	No Operation	
	EI		1 0 1 0 1 0 1 0				4	Enable Interrupt	
	DI		1 0 1 1 1 0 1 0				4	Disable Interrupt	
	HLT		0 1 0 0 1 0 0 0	0 0 1 1 1 0 1 1			12	Set Halt Mode	
	STOP		0 1 0 0 1 0 0 0	1 0 1 1 1 0 1 1			12	Set Stop Mode	

- \* 1. Data is B2 if rpa2 = D + byte, H + byte.
- 2. Data is B3 if rpa3 = D + byte, H + byte.
- 3. In the State item, a figure is in the right side of slash if rpa2 and rpa3 are D + byte, H + A, H + B, H + EA, H + byte.

**Remarks** The idle state when each instruction is skipped is different from the execution state as shown below.

1-byte instruction	: 4 states	3-byte instruction (with *)	: 10 states
2-byte instruction (with *)	: 7 states	3-byte instruction	: 11 states
2-byte instruction	: 8 states	4-byte instruction	: 14 states

- Note**
1. Instruction Group
  2. Call instructions

**5. LIST OF MODE REGISTERS**

Name of Mode Registers		Read/Write	Function
MA	MODE A register	W	Specifies bit-wise the input/output of the port A.
MB	MODE B register	W	Specifies bit-wise the input/output of the port B.
MCC	MODE CONTROL C register	W	Specifies bit-wise the port/control mode of the port C.
MC	MODE C register	W	Specifies bit-wise the input/output of the port C which is in port mode.
MM	MEMORY MAPPING register	W	Specifies the port/extension mode of port D and port F.
MF	MODE F register	W	Specifies bit-wise the input/output of the port F which is in port mode.
TMM	Timer mode register	R/W	Specifies operating mode of timer.
ETMM	Timer/event counter mode register	W	Specifies the operating mode of timer/event counter.
EOM	Timer/event counter output mode register	R/W	Control the output level of CO0 and CO1.
SML	Serial mode register	W	Specifies the operating mode of serial interface.
SMH		R/W	
MKL	Interrupt mask register	R/W	Specifies the enable/disable of the interrupt request.
MKH			
ANM	A/D channel mode register	R/W	Specifies the operating mode of A/D converter.
ZCM	Zero-cross mode register	W	Specifies the operation of zero-cross detector circuit.

6. ELECTRICAL SPECIFICATIONS

ABSOLUTE MAXIMUM RATINGS (T<sub>A</sub> = 25 °C)

PARAMETER	SYMBOL	TEST CONDITIONS	RATING	UNIT
Power supply voltage	V <sub>DD</sub>		-0.5 to +7.0	V
	AV <sub>DD</sub>		AV <sub>SS</sub> to V <sub>DD</sub> +0.5	V
	AV <sub>SS</sub>		-0.5 to +0.5	V
Input voltage	V <sub>I</sub>		-0.5 to V <sub>DD</sub> +0.5	V
Output voltage	V <sub>O</sub>		-0.5 to V <sub>DD</sub> +0.5	V
Output current low	I <sub>OL</sub>	All output pins	4.0	mA
		Total of all output pins	100	mA
Output current high	I <sub>OH</sub>	All output pins	-2.0	mA
		Total of all output pins	-50	mA
A/D converter reference input voltage	V <sub>AREF</sub>		-0.5 to AV <sub>DD</sub> +0.3	V
Operating ambient temperature	T <sub>A</sub>		-40 to +85	°C
Storage temperature	T <sub>stg</sub>		-65 to +150	°C

**Caution** Even if one of the parameters exceeds its absolute maximum rating even momentarily, the quality of the product may be degraded. The absolute maximum rating therefore specifies the upper or lower limit of the value at which the product can be used without physical damages. Be sure not to exceed or fall below this value when using the product. ★

**OSCILLATOR CHARACTERISTICS** (T<sub>A</sub> = -40 to +85 °C, V<sub>DD</sub> = AV<sub>DD</sub> = +5.0 V ±10 %, V<sub>SS</sub> = AV<sub>SS</sub> = 0 V, V<sub>DD</sub> -0.8 V ≤ AV<sub>DD</sub> ≤ V<sub>DD</sub>, 3.4 V ≤ V<sub>AREF</sub> ≤ AV<sub>DD</sub>)

RESONATOR	RECOMMENDED CIRCUIT	PARAMETER	TEST CONDITIONS	MIN.	MAX.	UNIT
Ceramic*1 or crystal resonator*2		Oscillator frequency (f <sub>xx</sub> )	A/D converter not used	4	15	MHz
			A/D converter used	5.8	15	MHz
External clock		X1 input frequency (f <sub>x</sub> )	A/D converter not used	4	15	MHz
			A/D converter used	5.8	15	MHz
		X1 rise time, fall time (t <sub>r</sub> , t <sub>f</sub> )		0	20	ns
		X1 input high, low level width (t <sub>0H</sub> , t <sub>0L</sub> )		20	250	ns

- Cautions**
1. Place oscillator circuit as close as possible to X1, X2 pins.
  2. Ensure that no other signal lines pass through the shadow area.

\* 1. The ceramic oscillators and external capacitance given in the following table are recommended.

MAKER	PRODUCT NAME	RECOMMENDED CONSTANTS	
		C1[pF]	C2[pF]
Murata Mfg. Co., Ltd	CSA7.37MT	30	30
	CST7.37MTW	On-chip	On-chip
	CSA12.0MT	30	30
	CST12.0MTW	On-chip	On-chip
	CSA15.00MX001	15	15
TDK Corp.	FCR8.0MC	On-chip	On-chip
	FCR10.0MC		
	FCR12.00MC		
	FCR15.0MC		

\* 2. When a crystal oscillator is used, the following external capacitance is recommended.  
C1 = C2 = 10 pF

**CAPACITANCE (T<sub>A</sub> = 25 °C, V<sub>DD</sub> = V<sub>SS</sub> = 0 V)**

PARAMETER	SYMBOL	TEST CONDITIONS	MIN.	TYP.	MAX.	UNIT
Input capacitance	C <sub>I</sub>	f <sub>c</sub> = 1 MHz Unmeasured pins returned to 0 V			10	pF
Output capacitance	C <sub>O</sub>				20	pF
Input-output capacitance	C <sub>IO</sub>				20	pF

**DC CHARACTERISTICS (TA = -40 to +85 °C, VDD = AVDD = +5.0 V ±10 %, VSS = AVSS = 0 V)**

PARAMETER	SYMBOL	TEST CONDITIONS	MIN.	TYP.	MAX.	UNIT	
Input voltage low	V <sub>IL1</sub>	All except $\overline{\text{RESET}}$ , $\overline{\text{STOP}}$ , $\overline{\text{NMI}}$ , $\overline{\text{SCK}}$ , INT1, TI, AN4 to AN7	0		0.8	V	
	V <sub>IL2</sub>	$\overline{\text{RESET}}$ , $\overline{\text{STOP}}$ , $\overline{\text{NMI}}$ , $\overline{\text{SCK}}$ , INT1, TI, AN4 to AN7	0		0.2 V <sub>DD</sub>	V	
Input voltage high	V <sub>1IH</sub>	All except $\overline{\text{RESET}}$ , $\overline{\text{STOP}}$ , $\overline{\text{NMI}}$ , $\overline{\text{SCK}}$ , INT1, TI, AN4 to AN7, X1, X2	2.2		V <sub>DD</sub>	V	
	V <sub>IH2</sub>	$\overline{\text{RESET}}$ , $\overline{\text{STOP}}$ , $\overline{\text{NMI}}$ , $\overline{\text{SCK}}$ , INT1, TI, AN4 to AN7, X1, X2	0.8 V <sub>DD</sub>		V <sub>DD</sub>	V	
Output voltage low	V <sub>OL</sub>	I <sub>OL</sub> = 2.0 mA			0.45	V	
Output voltage high	V <sub>OH</sub>	I <sub>OH</sub> = -1.0 mA	V <sub>DD</sub> -1.0			V	
		I <sub>OH</sub> = -100 μA	V <sub>DD</sub> -0.5			V	
Input current	I <sub>I</sub>	INT1*1, TI(PC3)*2; 0 V ≤ V <sub>I</sub> ≤ V <sub>DD</sub>			±200	μA	
Input leakage current	I <sub>LI</sub>	All except INT1, TI (PC3), 0 V ≤ V <sub>I</sub> ≤ V <sub>DD</sub>			±10	μA	
Output leakage current	I <sub>LO</sub>	0 V ≤ V <sub>O</sub> ≤ V <sub>DD</sub>			±10	μA	
AV <sub>DD</sub> power supply current	Al <sub>DD1</sub>	Operating mode f <sub>xx</sub> = 15 MHz		0.5	1.3	mA	
	Al <sub>DD2</sub>	STOP mode		10	20	μA	
V <sub>DD</sub> power supply current	I <sub>DD1</sub>	Operating mode f <sub>xx</sub> = 15 MHz		13	25	mA	
	I <sub>DD2</sub>	HALT mode f <sub>xx</sub> = 15 MHz		7	13	mA	
Data retention voltage	V <sub>DDDR</sub>	Hardware/software STOP mode	2.5			V	
Data retention current	I <sub>DDDR</sub>	Hardware/software*3	V <sub>DDDR</sub> = 2.5 V	1	15	μA	
		STOP mode	V <sub>DDDR</sub> = 5 V ±10%	10	50	μA	
Pull-up resistor*4	R <sub>L</sub>	Ports A, B and C	3.5 V ≤ V <sub>DD</sub> ≤ 5.5 V, V <sub>I</sub> = 0 V	17	27	75	kΩ

**Caution** For a detailed description of the hardware STOP mode, refer to the 87AD Series mPD78C18 User's Manual.

- \* 1. If self-bias should be generated by ZCM register.
- 2. If the control mode is set by MCC register, and self-bias should be generated by ZCM register.
- 3. If self-bias is not generated.
- 4. μPD78C11A and 78C12A only.

**AC CHARACTERISTICS** ( $T_A = -40$  to  $+85$  °C,  $V_{DD} = AV_{DD} = +5.0$  V  $\pm 10$  %,  $V_{SS} = AV_{SS} = 0$  V)  
**Read/write Operation:**

PARAMETER	SYMBOL	TEST CONDITIONS	MIN.	MAX.	UNIT
X1 input cycle time	t <sub>CYC</sub>		66	250	ns
Address setup time (to ALE ↓)	t <sub>AL</sub>		30		ns
Address hold time (from ALE ↓)	t <sub>LA</sub>	f <sub>XX</sub> = 15 MHz, C <sub>L</sub> = 100 pF	35		ns
$\overline{RD}$ ↓ delay time from address	t <sub>AR</sub>		100		ns
Address float time from $\overline{RD}$ ↓	t <sub>AFR</sub>	C <sub>L</sub> = 100 pF		20	ns
Data input time from address	t <sub>AD</sub>			250	ns
Data input time from ALE ↓	t <sub>LDR</sub>	f <sub>XX</sub> = 15 MHz, C <sub>L</sub> = 100 pF		135	ns
Data input time from $\overline{RD}$ ↓	t <sub>RD</sub>			120	ns
$\overline{RD}$ ↓ delay time from ALE ↓	t <sub>LR</sub>		15		ns
Data hold time (from $\overline{RD}$ ↑)	t <sub>RDH</sub>	C <sub>L</sub> = 100 pF	0		ns
ALE ↑ delay time from $\overline{RD}$ ↑	t <sub>RL</sub>	f <sub>XX</sub> = 15 MHz, C <sub>L</sub> = 100 pF	80		ns
$\overline{RD}$ low level width	t <sub>RR</sub>	In Data Read f <sub>XX</sub> = 15 MHz, C <sub>L</sub> = 100 pF	215		ns
		In OP Code Fetch f <sub>XX</sub> = 15 MHz, C <sub>L</sub> = 100 pF	415		ns
ALE high level width	t <sub>LL</sub>	f <sub>XX</sub> = 15 MHz, C <sub>L</sub> = 100 pF	90		ns
$\overline{M1}$ setup time (to ALE ↓)	t <sub>ML</sub>		30		ns
$\overline{M1}$ hold time (from ALE ↓)	t <sub>LM</sub>	f <sub>XX</sub> = 15 MHz	35		ns
$\overline{IO/M}$ setup time (to ALE ↓)	t <sub>IL</sub>		30		ns
$\overline{IO/M}$ hold time (from ALE ↓)	t <sub>LI</sub>		35		ns
$\overline{WR}$ ↓ delay time from address	t <sub>AW</sub>	f <sub>XX</sub> = 15 MHz, C <sub>L</sub> = 100 pF	100		ns
Data output time from ALE ↓	t <sub>LDW</sub>			180	ns
Data output time from $\overline{WR}$ ↓	t <sub>WD</sub>	C <sub>L</sub> = 100 pF		100	ns
$\overline{WR}$ ↓ delay time from ALE ↓	t <sub>LW</sub>		15		ns
Data setup time (to $\overline{WR}$ ↑)	t <sub>DW</sub>		165		ns
Data hold time (from $\overline{WR}$ ↑)	t <sub>WDH</sub>	f <sub>XX</sub> = 15 MHz, C <sub>L</sub> = 100 pF	60		ns
ALE ↑ delay time from $\overline{WR}$ ↑	t <sub>WL</sub>		80		ns
$\overline{WR}$ low level width	t <sub>WW</sub>		215		ns

**Serial Operation :**

PARAMETER	SYMBOL	TEST CONDITIONS		MIN.	MAX.	UNIT
SCK cycle time	tcyk	SCK input	*1	800		ns
			*2	400		ns
		SCK output		1.6		μs
SCK low level width	tkkl	SCK input	*1	335		ns
			*2	160		ns
		SCK output		700		ns
SCK high level width	tkkh	SCK input	*1	335		ns
			*2	160		ns
		SCK output		700		ns
RxD setup time (to SCK ↑)	trxk	*1	80		ns	
RxD hold time (from SCK ↑)	tkrx	*1	80		ns	
TxD delay time from SCK ↓	tktx	*1		210	ns	

- \* 1. If clock rate is × 1 in asynchronous mode, synchronous mode, or I/O interface mode.
- 2. If clock rate is × 16 or × 64 in asynchronous mode.

**Remarks** The numeric values in the table are those when fxx = 15 MHz, CL = 100 pF.

**Zero-Cross Characteristics :**

PARAMETER	SYMBOL	TEST CONDITIONS	MIN.	MAX.	UNIT
Zero-cross detection input	Vzx	AC combination 60 Hz sine wave	1	1.8	VAC <sub>P-P</sub>
Zero-cross accuracy	Azx		±135		mV
Zero-cross detection input frequency	fzx		0.05	1	kHz

**Other Operation :**

PARAMETER	SYMBOL	TEST CONDITIONS	MIN.	MAX.	UNIT
Tl high, low level width	t1H, t1L		6		tcyc
Cl high, low level width	tci1H, tci1L	Event count mode	6		tcyc
	tci2H, tci2L	Pulse width test mode	48		tcyc
NMI high, low level width	tniH, tniL		10		μs
INT1 high, low level width	t1H, t1L		36		tcyc
INT2 high, low level width	t2H, t2L		36		tcyc
AN4 to AN7, low level width	tanh, tanl		36		tcyc
RESET high, low level width	trsh, trsl		10		μs

**A/D CONVERTER CHARACTERISTICS** ( $T_A = -40$  to  $+85$  °C,  $V_{DD} = +5.0$  V  $\pm 10$  %,  $V_{SS} = AV_{SS} = 0$  V,  $V_{DD} - 0.5$  V  $\leq AV_{DD} \leq V_{DD}$ ,  $3.4$  V  $\leq V_{AREF} \leq AV_{DD}$ )

PARAMETER	SYMBOL	TEST CONDITIONS	MIN.	TYP.	MAX.	UNIT
Resolution			8			Bits
Absolute accuracy*		$3.4$ V $\leq V_{AREF} \leq AV_{DD}$ , $66$ ns $\leq t_{CYC} \leq 170$ ns			$\pm 0.8\%$	FSR
		$4.0$ V $\leq V_{AREF} \leq AV_{DD}$ , $66$ ns $\leq t_{CYC} \leq 170$ ns			$\pm 0.6\%$	FSR
		$T_A = -10$ to $+70$ °C, $4.0$ V $\leq V_{AREF} \leq AV_{DD}$ , $66$ ns $\leq t_{CYC} \leq 170$ ns			$\pm 0.4\%$	FSR
Conversion time	$t_{CONV}$	$66$ ns $\leq t_{CYC} \leq 110$ ns	576			t <sub>CYC</sub>
		$110$ ns $\leq t_{CYC} \leq 170$ ns	432			t <sub>CYC</sub>
Sampling time	$t_{SAMP}$	$66$ ns $\leq t_{CYC} \leq 110$ ns	96			t <sub>CYC</sub>
		$110$ ns $\leq t_{CYC} \leq 170$ ns	72			t <sub>CYC</sub>
Analog input voltage	$V_{IAN}$	AN0 to AN7 (including unused pins)	-0.3		$V_{AREF} + 0.3$	V
Analog input impedance	$R_{AN}$			50		MΩ
Reference voltage	$V_{AREF}$		3.4		$AV_{DD}$	V
$V_{AREF}$ current	$I_{AREF1}$	Operating mode		1.5	3.0	mA
	$I_{AREF2}$	STOP mode		0.7	1.5	mA
$AV_{DD}$ power supply current	$AI_{DD1}$	Operating mode $f_{XX} = 15$ MHz		0.5	1.3	mA
	$AI_{DD2}$	STOP mode		10	20	μA

\* Quantization error ( $\pm 1/2$  LSB) is not included.

**AC Timing Test Point**

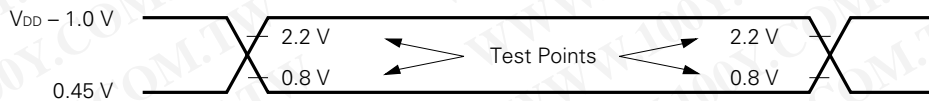

## tcyc-Dependent AC Characteristics Expression

PARAMETER	EXPRESSION	MIN./MAX.	UNIT
tAL	2T - 100	MIN.	ns
tLA	T - 30	MIN.	ns
tAR	3T - 100	MIN.	ns
tAD	7T - 220	MAX.	ns
tLDR	5T - 200	MAX.	ns
tRD	4T - 150	MAX.	ns
tLR	T - 50	MIN.	ns
tRL	2T - 50	MIN.	ns
tRR	4T - 50 (In data read)	MIN.	ns
	7T - 50 (In OP code fetch)		
tLL	2T - 40	MIN.	ns
tML	2T - 100	MIN.	ns
tLM	T - 30	MIN.	ns
tIL	2T - 100	MIN.	ns
tLI	T - 30	MIN.	ns
tAW	3T - 100	MIN.	ns
tLDW	T + 110	MAX.	ns
tLW	T - 50	MIN.	ns
tDW	4T - 100	MIN.	ns
tWDH	2T - 70	MIN.	ns
tWL	2T - 50	MIN.	ns
tww	4T - 50	MIN.	ns
tcyk	12T ( $\overline{\text{SCK}}$ input)*1/6T ( $\overline{\text{SCK}}$ input)*2	MIN.	ns
	24T ( $\overline{\text{SCK}}$ output)		
tkkL	5T + 5 ( $\overline{\text{SCK}}$ input)*1/2.5T + 5 ( $\overline{\text{SCK}}$ input)*2	MIN.	ns
	12T - 100 ( $\overline{\text{SCK}}$ output)		
tkkH	5T + 5 ( $\overline{\text{SCK}}$ input)*1/2.5T + 5 ( $\overline{\text{SCK}}$ input)*2	MIN.	ns
	12T - 100 ( $\overline{\text{SCK}}$ output)		

\* 1. If clock rate is  $\times 1$ , in asynchronous mode, synchronous mode, or I/O interface mode.

2. If clock rate is  $16 \times 64$ , in asynchronous mode.

**Cautions** 1.  $T = t_{CYC} = 1/f_{XX}$

2. Other items which are not listed in this table are not dependent on oscillator frequency (fXX).

**Timing Waveform**  
**Read operation**

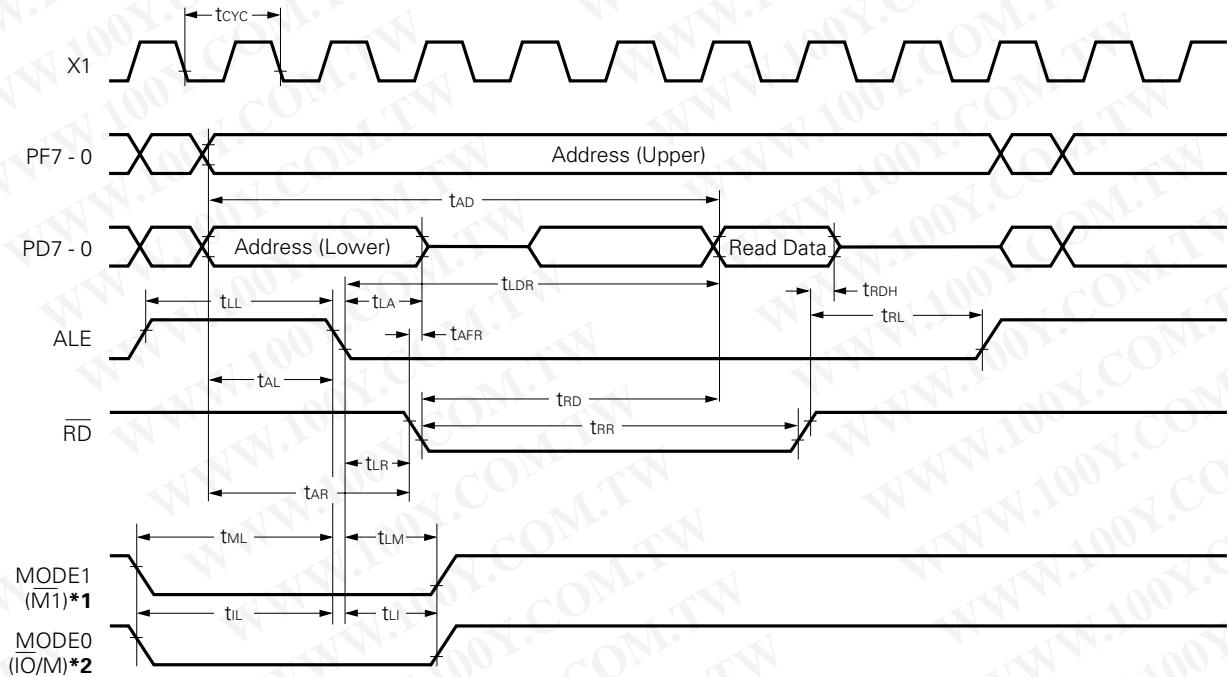

- \* 1. When MODE1 pin is pulled up,  $\overline{M1}$  signal is output to MODE1 pin in the 1st OP code fetch cycle.
- 2. When MODE0 pin is pulled up,  $\overline{IO/M}$  signal is output to MODE0 pin in sr to sr2 register read cycle.

**Write operation**

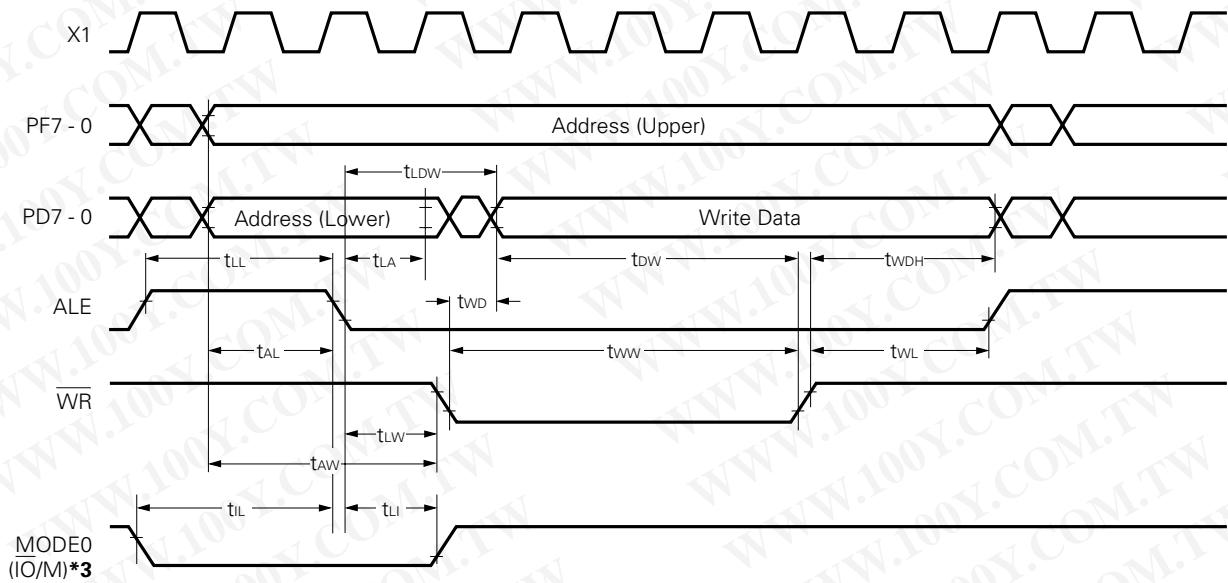

- \* 3. When MODE0 pin is pulled up,  $\overline{IO/M}$  signal is output to MODE0 pin in sr to sr2 register write cycle.

**Serial Operation**

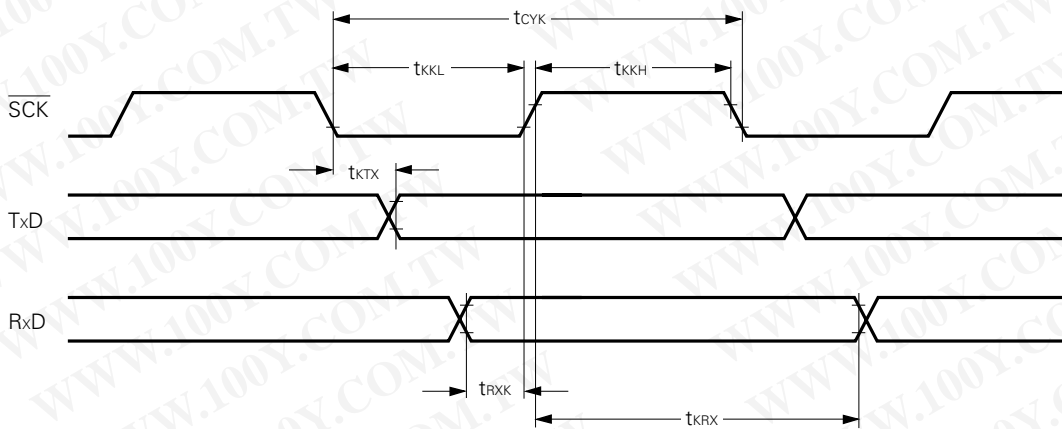

**Timer Input Timing**

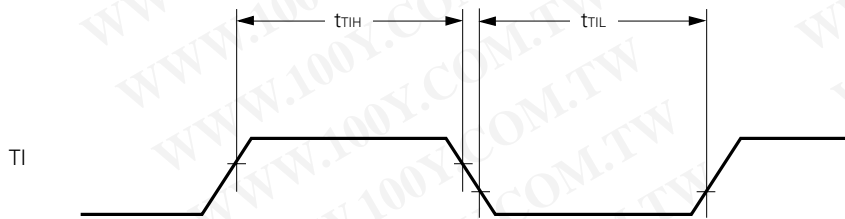

**Timer/Event Counter Input Timing**

Event Counter Mode

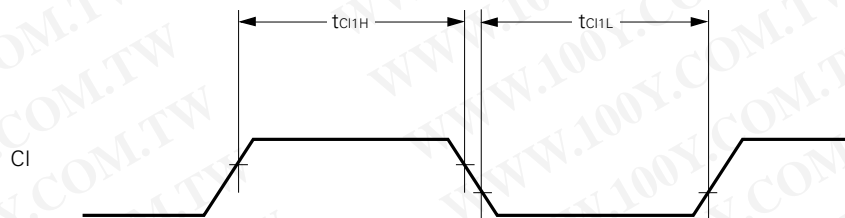

Pulse Width Test Mode

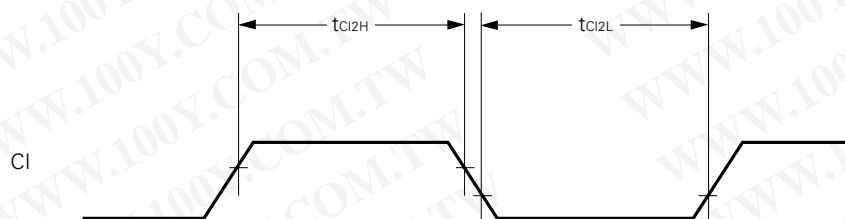

**Interrupt Input Timing**

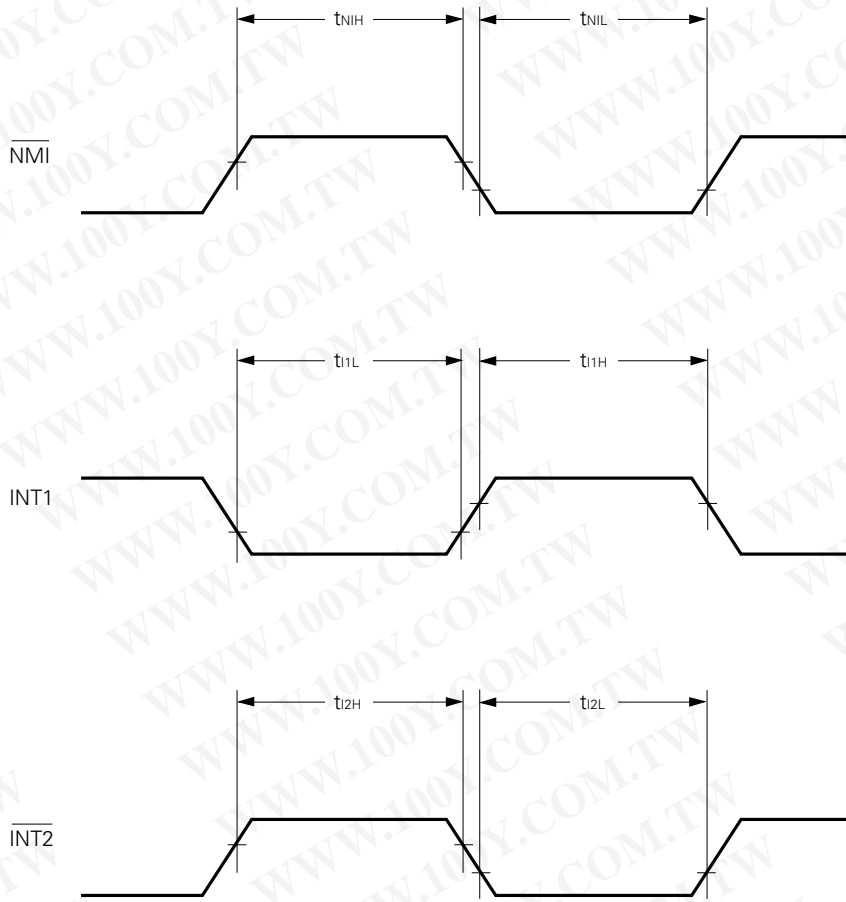

**Reset Input Timing**

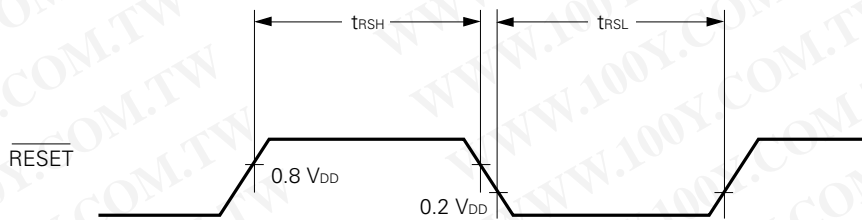

**External Clock Timing**

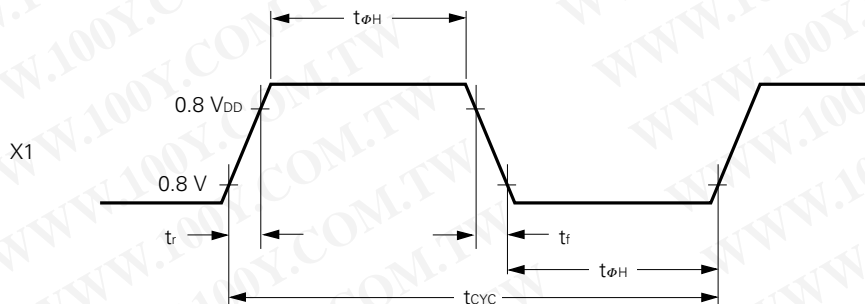

**DATA MEMORY STOP MODE LOW POWER SUPPLY VOLTAGE DATA RETENTION CHARACTERISTICS**  
 (T<sub>A</sub> = -40 to +85 °C)

PARAMETER	SYMBOL	TEST CONDITIONS	MIN.	TYP.	MAX.	UNIT
Data retention power supply voltage	V <sub>DDDR</sub>		2.5		5.5	V
Data retention power supply current	I <sub>DDDR</sub>	V <sub>DDDR</sub> = 2.5 V		1	15	μA
		V <sub>DDDR</sub> = 5 V ±10%		10	50	μA
V <sub>DD</sub> rise/fall time	t <sub>RV</sub> D, t <sub>FV</sub> D		200			μs
STOP setup time (to V <sub>DD</sub> )	t <sub>S</sub> S <sub>T</sub> V <sub>D</sub>		12T +0.5			μs
STOP hold time (from V <sub>DD</sub> )	t <sub>H</sub> V <sub>D</sub> S <sub>T</sub>		12T +0.5			μs

★

**Data Retention Timing**

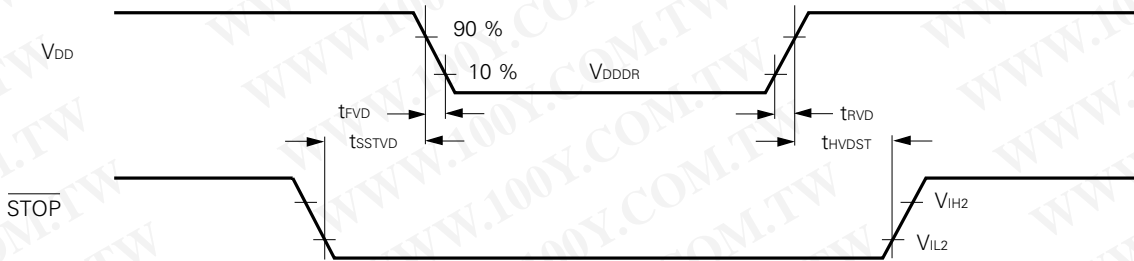

7. CHARACTERISTIC CURVES (REFERENCE VALUES)

I<sub>DD1</sub>, I<sub>DD2</sub> vs V<sub>DD</sub>

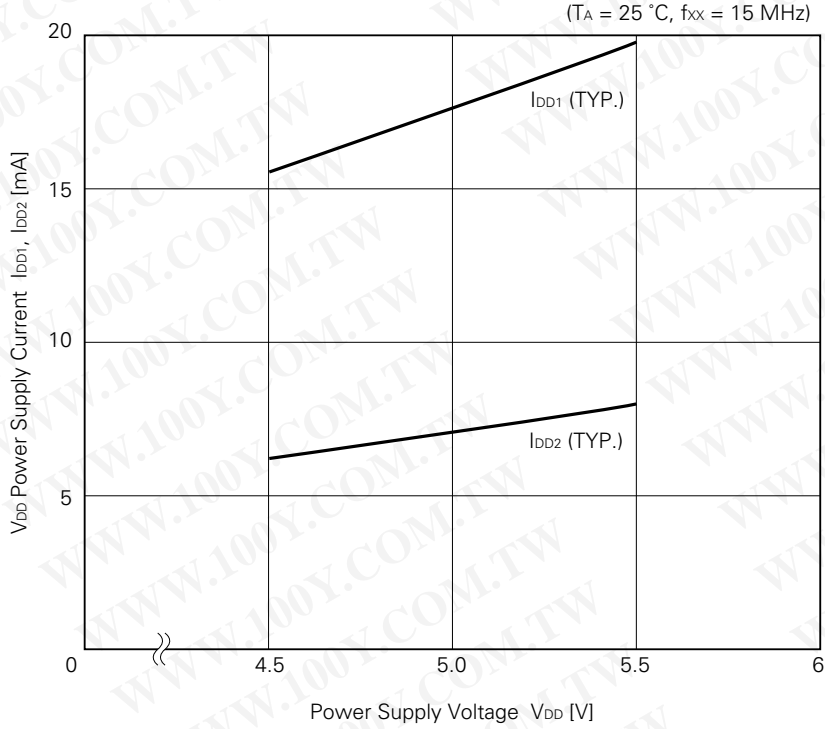

I<sub>DD1</sub>, I<sub>DD2</sub> vs f<sub>xx</sub>

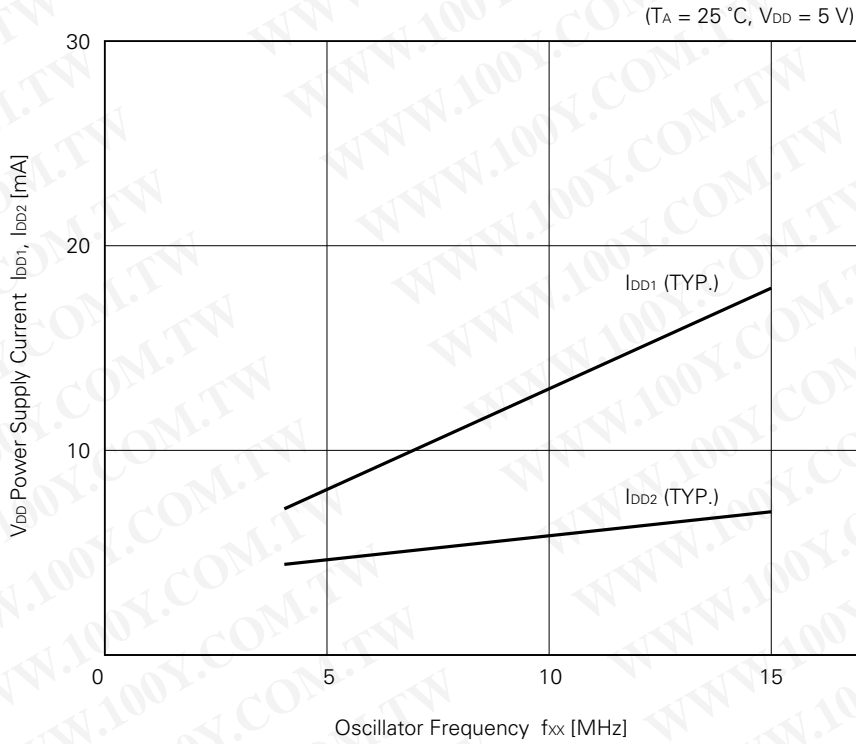

I<sub>OL</sub> vs V<sub>OL</sub>

(T<sub>A</sub> = 25 °C, V<sub>DD</sub> = 5 V)

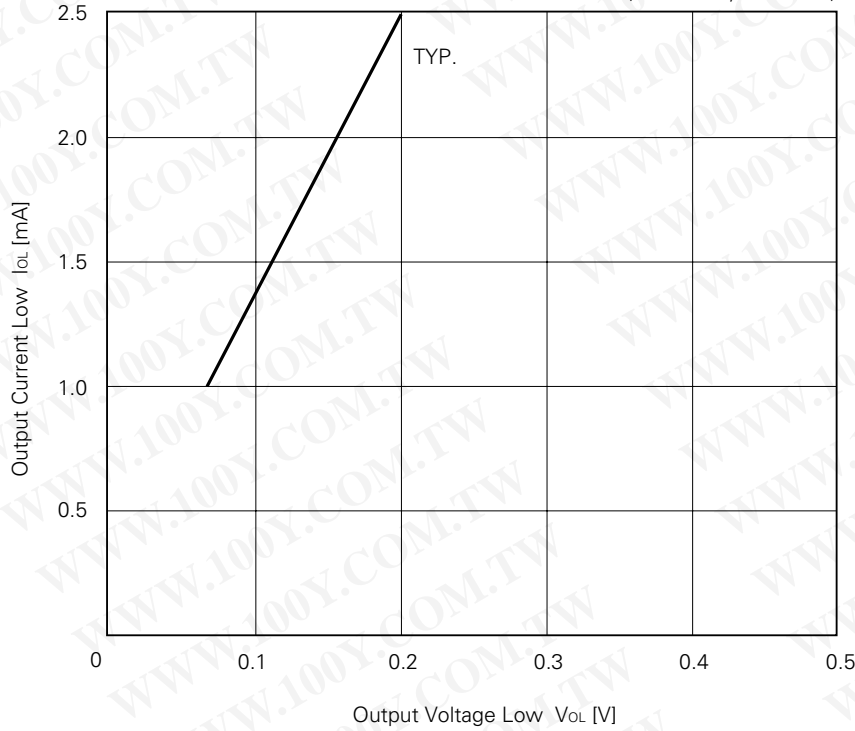

I<sub>OH</sub> vs V<sub>OH</sub>

(T<sub>A</sub> = 25 °C, V<sub>DD</sub> = 5 V)

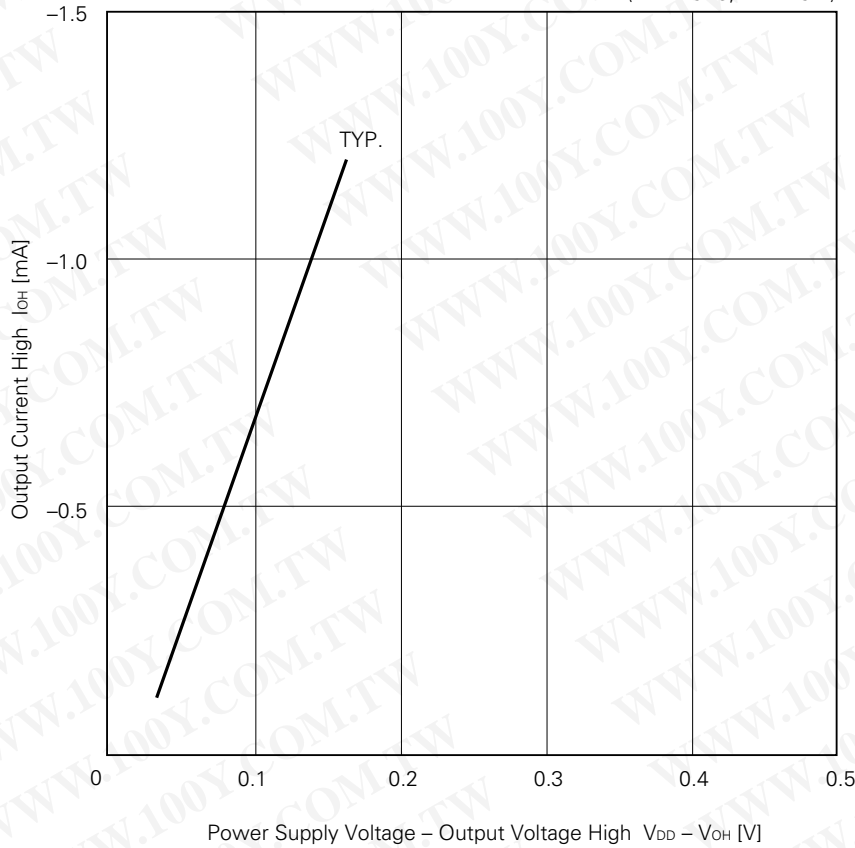

I<sub>DDDR</sub> vs V<sub>DDDR</sub>

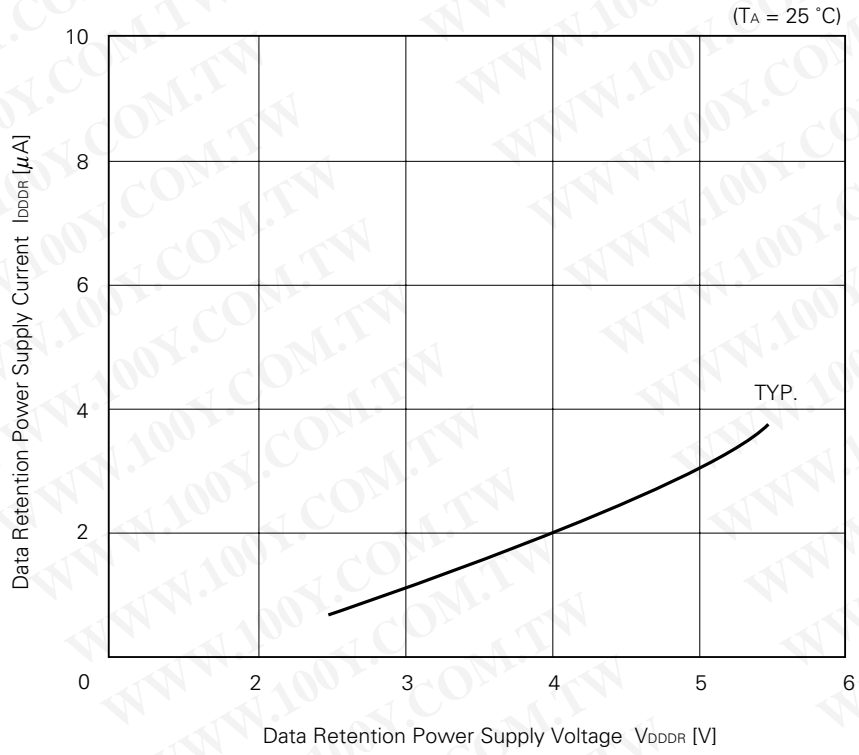

8. DIFFERENCES IN 87AD SERIES PRODUCTS (1/2)

Item	Product Name	μPD7810, 7811*1	μPD7810H, 7811H	μPD78C10, 78C11*1
Number of instructions		158 kinds		159 kinds (STOP instruction added)
On-chip ROM		ROM less (μPD7810) 4K × 8 bits (μPD7811)	ROM less (μPD7810H) 4K × 8 bits (μPD7811H)	ROM less (μPD78C10) 4K × 8 bits (μPD78C11)
On-chip RAM		256 × 8 bits		
Number of special registers		27		28 (ZCM register added)
Operating frequency		10 to 12 MHz	4 to 10 MHz	4 to 15 MHz*2
Power supply voltage		5 V ± 5 %	5 V ± 10 %	5 V ± 10 %
Operating temperature range		-10 to +70 °C	-40 to +85 °C	-40 to +85 °C
Standby function		Thirty-two bytes of the on-chip RAM 256 bytes of data are held by low power supply voltage (3.2 V)		Three kinds: HALT mode, software STOP mode, and hardware STOP mode. All data of on-chip RAM are held by low power supply voltage (2.5V) in software/hardware STOP mode.
Number of HALT instruction state		11		12
HALT mode	CPU operation	M3 T2 cycle repeated		Stop
	ALE	High level		Low level
Zero crossing detector self-bias control		Self-bias control impossible		Self-bias control possible (by ZCM register specification)
NMI, RESET noise elimination method		By clock sampling		By analog delay
A/D converter operation control		Operation stop impossible		Operation stop possible (V <sub>AREF</sub> pin operation)
A/D converter absolute accuracy (Unit: FSR)		0.4% (T <sub>A</sub> = -10 to +50 °C) 0.6% (T <sub>A</sub> = -40 to +85 °C)	0.4% (T <sub>A</sub> = -10 to +70 °C)*3	0.4% (T <sub>A</sub> = -10 to +70 °C, V <sub>AREF</sub> = 4.0V to AV <sub>DD</sub> ) 0.6% (T <sub>A</sub> = -40 to +85 °C, V <sub>AREF</sub> = 4.0V to AV <sub>DD</sub> ) 0.8% (T <sub>A</sub> = -40 to +85 °C, V <sub>AREF</sub> = 3.4V to AV <sub>DD</sub> )
V <sub>AREF</sub> voltage range		AV <sub>CC</sub> to 0.5V to AV <sub>CC</sub>		3.4 V to AV <sub>DD</sub>
Analog input voltage range		0V to V <sub>AREF</sub>		
I <sub>CC</sub> /I <sub>DD1</sub>		6 mA Typ.		0.5 mA Typ.
I <sub>DD2</sub>		—		10 μA Typ.
I <sub>AREF1</sub> /I <sub>AREF1</sub>		0.5 mA Typ.	2.0 mA Typ.	1.5 mA Typ.
I <sub>AREF2</sub>		—		0.7 mA Typ.

- \* 1. μPD7810, 7811, 78C10 and 78C11 are maintenance products.
- 2. K, E, P masks apply from 4 MHz to 12 MHz.
- 3. The μPD7810HG and 7811HG G masks, μPD7810HCW and 7811HCW K masks apply T<sub>A</sub> = 0 to +70 °C.

μPD78C10A, 78C11A, 78C12A	μPD78CP14	μPD78CP18
159 kinds (STOP instruction added)		
ROM less (μPD78C10A) 4K × 8 bits (μPD78C11A) 8K × 8 bits (μPD78C12A)	16K × 8 bits (PROM)	32K × 8 bits (PROM)
256 × 8 bits		1024 × 8 bits
28 (ZCM register added)		
4 to 15 MHz 5 V ±10 % -40 to +85 °C	6 to 15 MHz 5 V ±5 % -40 to +85 °C	4 to 15 MHz 5 V ±10 % -40 to +85 °C
<p>Three kinds: Halt mode, software STOP mode, and hardware STOP mode. All data of on-chip RAM are held by low power supply voltage (2.5 V) in software/hardware STOP mode.</p>		
12		
STOP		
Low level		
Self-bias control possible (by ZCM register specification)		
By analog delay		
Operation stop impossible (V <sub>AREF</sub> pin operation)		
<p>0.4% (T<sub>A</sub> = -10 to +70 °C, V<sub>AREF</sub> = 4.0 V to AV<sub>DD</sub>)            0.6% (T<sub>A</sub> = -40 to +85 °C, V<sub>AREF</sub> = 4.0 V to AV<sub>DD</sub>)            0.8% (T<sub>A</sub> = -40 to +85 °C, V<sub>AREF</sub> = 3.4 V to AV<sub>DD</sub>)</p>		
3.4V to AV <sub>DD</sub>		
-0.3 V to V <sub>AREF</sub> + 0.3 V	0V to V <sub>AREF</sub>	-0.3 V to V <sub>AREF</sub> + 0.3 V
0.5mA Typ.		
10 μA Typ.		
1.5 mA Typ.		
0.7 mA Typ.		

DIFFERENCES IN 87AD SERIES PRODUCTS (2/2)

Item		Product Name	μPD7810, 7811*1	μPD7810H, 7811H	μPD78C10, 78C11*1
Operation during RESET	RD/WR		High level		High-impedance
	ALE		Output		
	PD/PF*4		Zero is output at the pin specified by the address bus. Other pins are high impedance.		
On-chip pull-up register (Mask option)			Impossible		
Device configuration			NMOS		CMOS
Standby current			3.2 mA (−10 to +70°C) MAX. 3.5 mA (−40 to +85°C) MAX.	3.2 mA MAX.	50 μA MAX. (V <sub>DD</sub> = 5 V ±10 %)
Current consumption			203.2 mA (−10 to +70°C) MAX. 223.5 mA (−40 to +85°C) MAX.	203.2 mA MAX.	25 mA MAX.
SCK (Unit: ns)	Cycle time input		20T	*5	
	Low level width		10T + 80		
	High level width		10T − 80		
Bus timing (Unit: ns)	T <sub>LDW</sub>		T + 110		
	T <sub>WD</sub>		100		
	T <sub>DW</sub>		4T − 100		
Hardware STOP mode restrictions			—		Yes
Asynchronous mode restrictions during external SCK input.			No		Yes
Package			64-pin plastic shrink DIP 64-pin plastic QUIP straight*7 64-pin plastic QUIP	64-pin plastic shrink DIP 64-pin plastic QUIP straight*8 64-pin plastic QUIP 64-pin plastic QFP (14 × 20 mm, 2.05 mm thickness) 64-pin plastic QFP (14 × 20 mm, 2.70 mm thickness) 68-pin plastic QFJ	
Pin connection*10			V <sub>CC</sub> (64-pin), V <sub>DD</sub> (63-pin)		V <sub>DD</sub> (64-pin), STOP (63-pin)

\* 1. μPD7810, 7811, 78C10 and 78C11 are maintenance products.

4. For μPD7810, 7810H, 78C10 and 78C10A.

5. (Unit : ns)

		For the asynchronous mode with clock rate x1, synchronous mode, and I/O interface mode	For the asynchronous mode with clock rate ×16 and ×64
SCK	Cycle time input	12T	6T
	Low level width	5T + 5	2.5T + 5
	High level width	5T + 5	2.5T + 5

Remarks T = tcyc = 1/f<sub>xx</sub>

μPD78C10A, 78C11A, 78C12A	μPD78CP14	μPD78CP18
High-impedance		
Only μPD78C11A, 78C12A possible (ports A, B, C)	Impossible	
CMOS		
50 μA MAX. (V <sub>DD</sub> = 5 V ± 10 %)	1 mA MAX. (V <sub>DD</sub> = 5 V ± 5 %)	50 μA MAX. (V <sub>DD</sub> = 5 V ± 10 %)
25 mA MAX.	32 mA MAX.	35 mA MAX.
*5		
T + 110		T + 130
110		140
4T - 100		4T - 140
Yes*6	No	
No		
64-pin plastic shrink DIP 64-pin plastic QUIP 64-pin plastic QFP (14 × 20 mm, 2.70 mm thickness) 64-pin plastic QUIP 64-pin plastic QFP (14 × 20 mm, 2.70 mm thickness) 68-pin plastic QFJ	64-pin plastic shrink DIP 64-pin plastic QUIP 64-pin plastic QFP (14 × 20 mm, 2.70 mm thickness) 68-pin plastic QFJ 64-pin ceramic shrink DIP with window 64-pin ceramic QUIP with window 64-pin ceramic WQFN	64-pin plastic shrink DIP 64-pin plastic QUIP 64-pin plastic QFP (14 × 20 mm, 2.70 mm thickness) 64-pin ceramic shrink DIP with window 64-pin ceramic WQFN
	V <sub>DD</sub> (64-pin), STOP (63-pin)	

- \* 6. K mask products only
- 7. μPD7811, 7811H only
- 8. μPD78C11, only
- 9. μPD78C11A, 78C12A only
- 10. Items in the parentheses are the pin numbers for the 64-pin plastic shrink DIP, 64-pin plastic QUIP straight and 64-pin plastic QUIP.

**Caution** Since the oscillator characteristics, I/O level, and some internal operation timing are different, be careful when studying direct replacement of the mPD78C10A, 78C11A, 78C12A and μPD7810, 7811, 7810H, 7811H, 78C10, 78C11.

9. PACKAGE INFORMATION

64 PIN PLASTIC SHRINK DIP (750 mil)

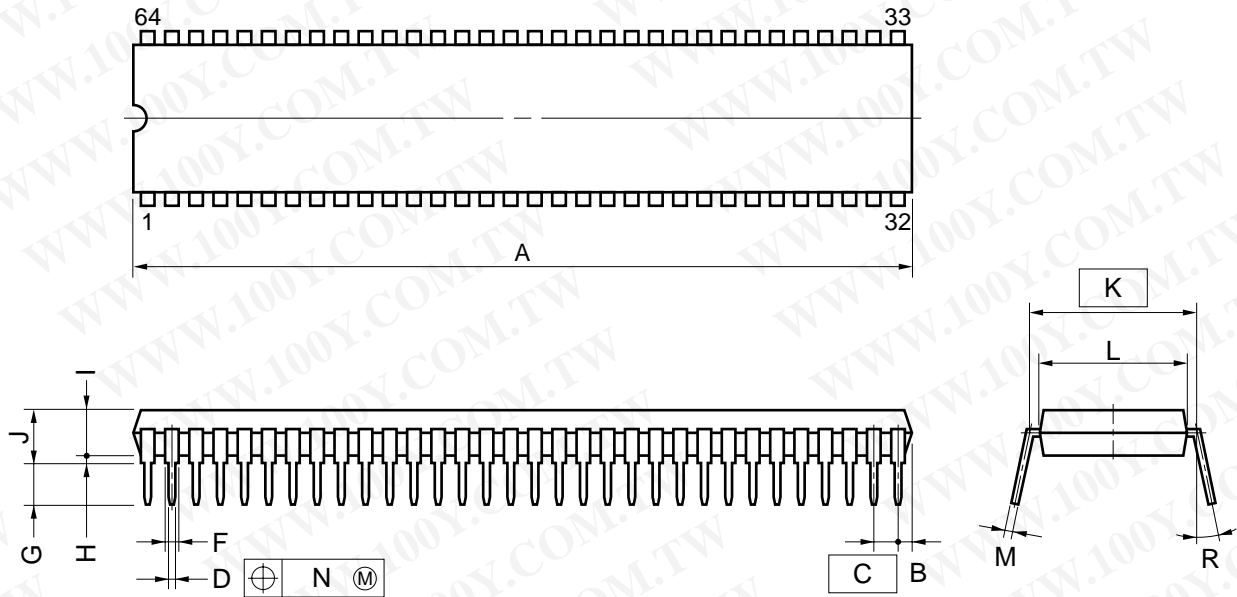

NOTE

- 1) Each lead centerline is located within 0.17 mm (0.007 inch) of its true position (T.P.) at maximum material condition.
- 2) Item "K" to center of leads when formed parallel.

ITEM	MILLIMETERS	INCHES
A	58.68 MAX.	2.311 MAX.
B	1.78 MAX.	0.070 MAX.
C	1.778 (T.P.)	0.070 (T.P.)
D	0.50±0.10	0.020 <sup>+0.004</sup> <sub>-0.005</sub>
F	0.9 MIN.	0.035 MIN.
G	3.2±0.3	0.126±0.012
H	0.51 MIN.	0.020 MIN.
I	4.31 MAX.	0.170 MAX.
J	5.08 MAX.	0.200 MAX.
K	19.05 (T.P.)	0.750 (T.P.)
L	17.0	0.669
M	0.25 <sup>+0.10</sup> <sub>-0.05</sub>	0.010 <sup>+0.004</sup> <sub>-0.003</sub>
N	0.17	0.007
R	0~15°	0~15°

P64C-70-750A,C-1

64PIN PLASTIC QUIP (STRAIGHT)

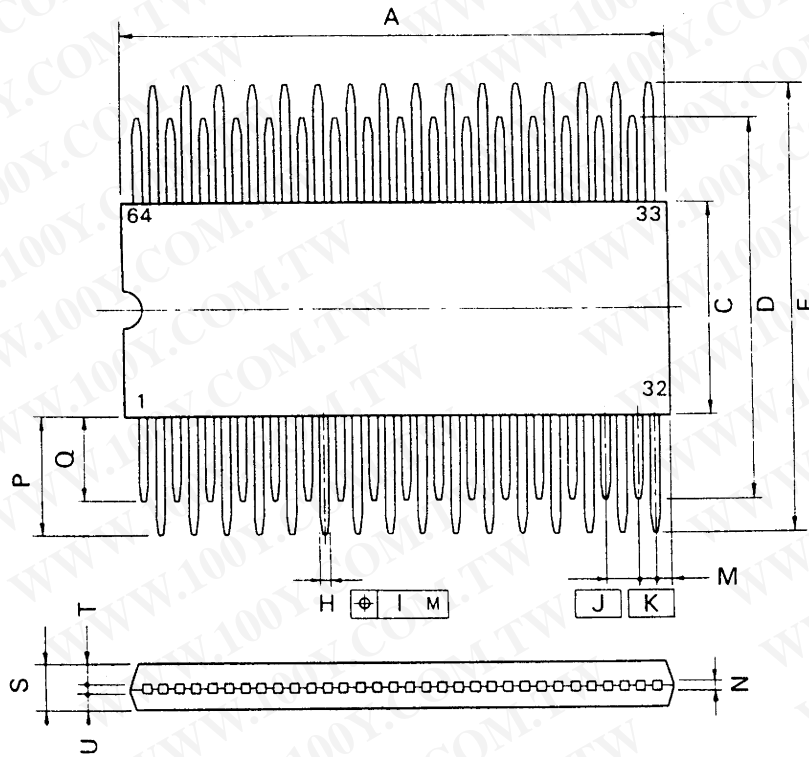

P64GQ-100-37-1

NOTE

Each lead centerline is located within 0.25 mm (0.010 inch) of its true position (T.P.) at maximum material condition.

ITEM	MILLIMETERS	INCHES
A	41.5 <sup>+0.3</sup>	1.634 <sup>+0.012</sup>
C	16.5	0.650
D	30.0 <sup>±0.4</sup>	1.181 <sup>±0.016</sup>
E	35.1 <sup>±0.4</sup>	1.382 <sup>±0.016</sup>
H	0.50 <sup>±0.10</sup>	0.020 <sup>+0.004</sup>
I	0.25	0.010
J	2.54 (T.P.)	0.100 (T.P.)
K	1.27 (T.P.)	0.050 (T.P.)
M	1.1 <sup>+0.15</sup>	0.043 <sup>+0.006</sup>
N	0.25 <sup>+0.08</sup>	0.010 <sup>+0.003</sup>
P	9.3 <sup>±0.2</sup>	0.366 <sup>+0.008</sup>
Q	6.75 <sup>±0.2</sup>	0.266 <sup>+0.008</sup>
S	3.6 <sup>±0.1</sup>	0.142 <sup>+0.004</sup>
T	1.8 <sup>±0.1</sup>	0.071 <sup>+0.004</sup>
U	1.55 <sup>±0.1</sup>	0.061 <sup>±0.004</sup>

64 PIN PLASTIC QUIP

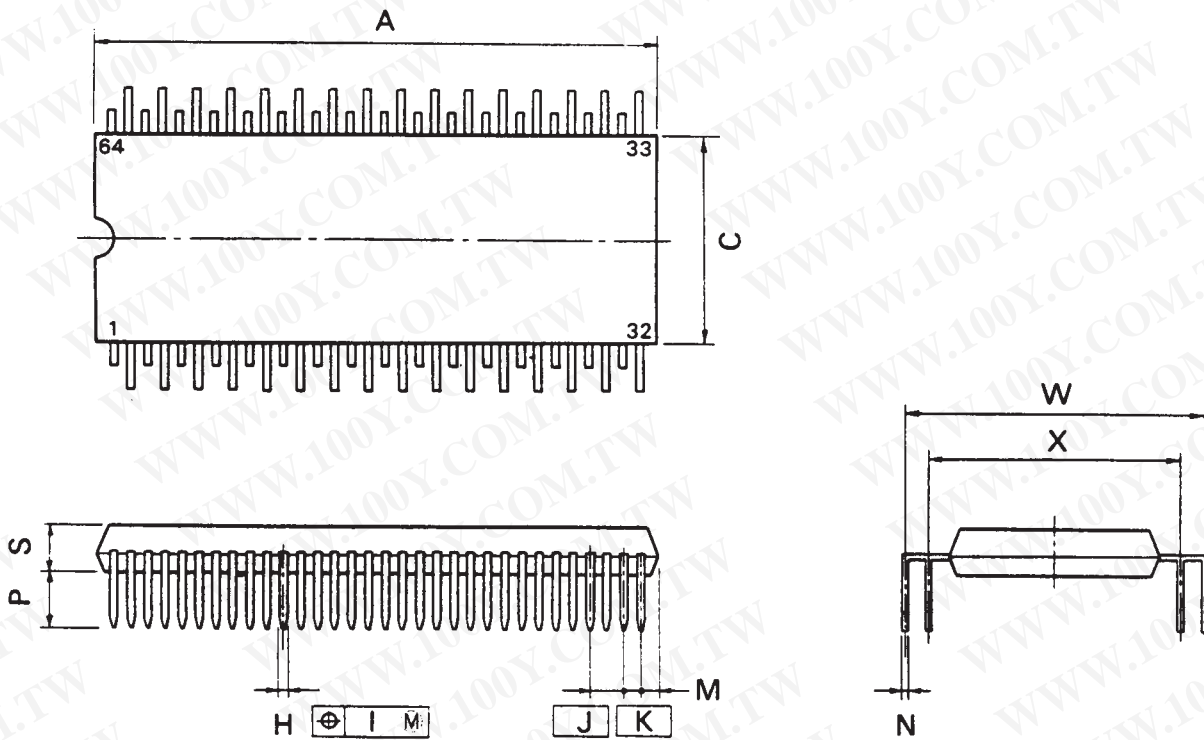

P64GQ-100-36

NOTE

Each lead centerline is located within 0.25 mm (0.010 inch) of its true position (T.P.) at maximum material condition.

ITEM	MILLIMETERS	INCHES
A	41.5 <sup>+0.3</sup>	1.634 <sup>+0.012</sup>
C	16.5	0.650
H	0.50 <sup>±0.10</sup>	0.020 <sup>±0.004</sup>
I	0.25	0.010
J	2.54 (T.P.)	0.100 (T.P.)
K	1.27 (T.P.)	0.050 (T.P.)
M	1.1 <sup>±0.1</sup>	0.043 <sup>±0.004</sup>
N	0.25 <sup>±0.08</sup>	0.010 <sup>±0.003</sup>
P	4.0 <sup>±0.3</sup>	0.157 <sup>±0.012</sup>
S	3.6 <sup>±0.1</sup>	0.142 <sup>±0.004</sup>
W	24.13 <sup>±1.05</sup>	0.950 <sup>±0.042</sup>
X	19.05 <sup>±1.05</sup>	0.750 <sup>±0.042</sup>

64PIN PLASTIC QFP (14 × 20) (UNIT: mm)

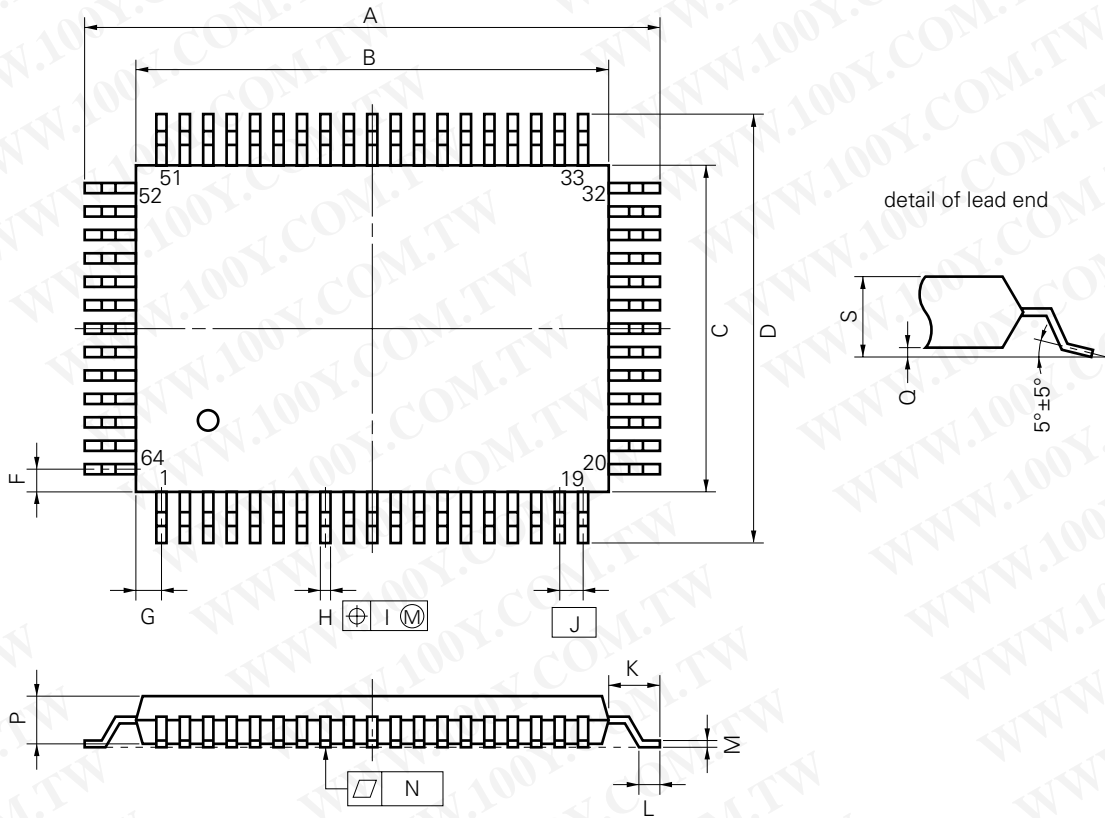

P64GF-100-3B8,3BE,3BR-1

**NOTE**

Each lead centerline is located within 0.20 mm (0.008 inch) of its true position (T.P.) at maximum material condition.

ITEM	MILLIMETERS	INCHES
A	23.6±0.4	0.929±0.016
B	20.0±0.2	0.795 <sup>+0.009</sup> <sub>-0.008</sub>
C	14.0±0.2	0.551 <sup>+0.009</sup> <sub>-0.008</sub>
D	17.6±0.4	0.693±0.016
F	1.0	0.039
G	1.0	0.039
H	0.40±0.10	0.016 <sup>+0.004</sup> <sub>-0.005</sub>
I	0.20	0.008
J	1.0 (T.P.)	0.039 (T.P.)
K	1.8±0.2	0.071 <sup>+0.008</sup> <sub>-0.009</sub>
L	0.8±0.2	0.031 <sup>+0.009</sup> <sub>-0.008</sub>
M	0.15 <sup>+0.10</sup> <sub>-0.05</sub>	0.006 <sup>+0.004</sup> <sub>-0.003</sub>
N	0.12	0.005
P	2.7	0.106
Q	0.1±0.1	0.004±0.004
S	3.0 MAX.	0.119 MAX.

ES 64PIN CERAMIC QFP (REFERENCE DRAWING) (UNIT: mm)

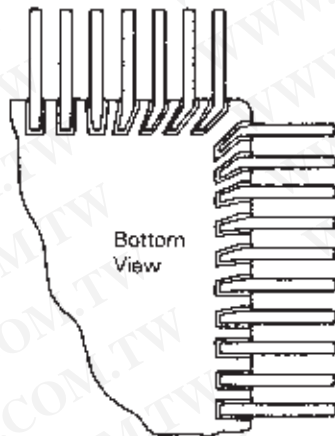
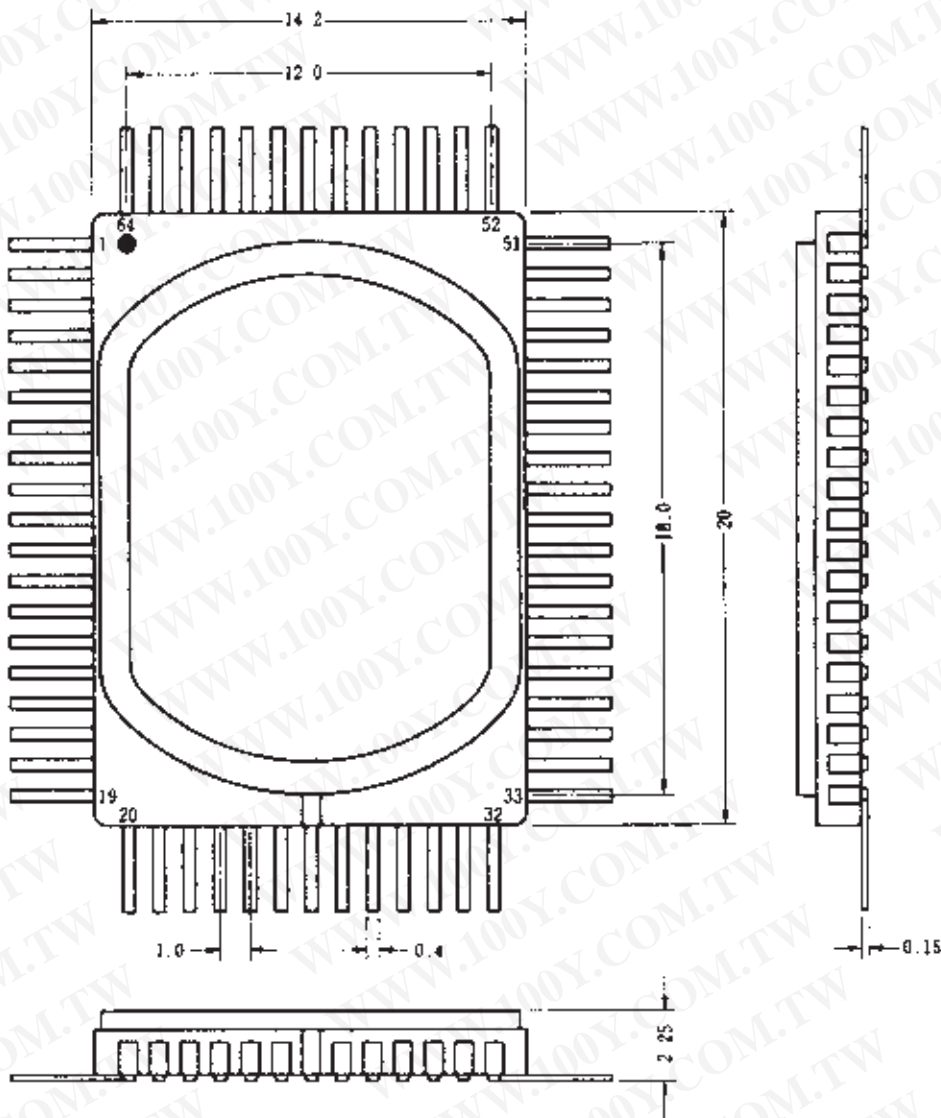

- Cautions**
1. The metal cap is connected to pin 26 and is  $V_{SS}$  (GND) level.
  2. The bottom leads are tilted.
  3. Since cutting of the end of the leads is no process-controlled, the lead length is unspecified.

68PIN PLASTIC QFJ (□ 950 mil) (UNIT: mm)

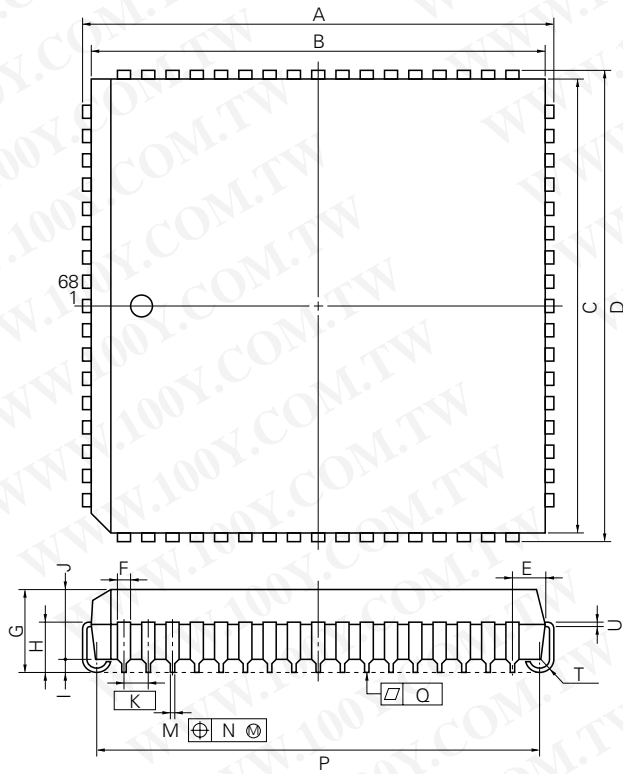

P68L-50A1-2

**NOTE**

Each lead centerline is located within 0.12 mm (0.005 inch) of its true position (T.P.) at maximum material condition.

ITEM	MILLIMETERS	INCHES
A	25.2±0.2	0.992±0.008
B	24.20	0.953
C	24.20	0.953
D	25.2±0.2	0.992±0.008
E	1.94±0.15	0.076 <sup>+0.007</sup> <sub>-0.006</sub>
F	0.6	0.024
G	4.4±0.2	0.173 <sup>+0.009</sup> <sub>-0.008</sub>
H	2.8±0.2	0.110 <sup>+0.009</sup> <sub>-0.008</sub>
I	0.9 MIN.	0.035 MIN.
J	3.4	0.134
K	1.27 (T.P.)	0.050 (T.P.)
M	0.40±1.0	0.016 <sup>+0.004</sup> <sub>-0.005</sub>
N	0.12	0.005
P	23.12±0.20	0.910 <sup>+0.009</sup> <sub>-0.008</sub>
Q	0.15	0.006
T	R 0.8	R 0.031
U	0.20 <sup>+0.10</sup> <sub>-0.05</sub>	0.008 <sup>+0.004</sup> <sub>-0.002</sub>

★ 10. RECOMMENDED SOLDERING CONDITIONS

The μPD78C10A, 78C11A, and 78C12A should be soldered and mounted under the conditions recommended in the table below.

For detail of recommended soldering conditions, refer to the information document "Semiconductor Device Mounting Technology Manual" (IEI-1207).

For soldering methods and conditions other than those recommended below, contact our sales personnel.

Table 10-1 Surface Mounting Type Soldering Conditions

- (1) μPD78C10AGF-3BE : 64-pin plastic QFP (14 × 20 mm)
- μPD78C11AGF-xxx-3BE : 64-pin plastic QFP (14 × 20 mm)
- μPD78C12AGF-xxx-3BE : 64-pin plastic QFP (14 × 20 mm)

Soldering Method	Soldering Conditions	Recommended Condition Symbol
Infrared reflow	Package peak temperature : 235 °C, Duration : 30 sec. max. (210 °C min.), Number of times : 2 max. <Points to note> (1) Start the second reflow after the device temperature by the first reflow returns to normal. (2) Flux washing by the water after the first reflow should be avoided.	IR35-00-2
VPS	Package peak temperature : 215 °C, Duration : 40 sec. max. (200 °C min.), Number of times : 2 max. <Points to note> (1) Start the second reflow after the device temperature by the first reflow returns to normal. (2) Flux washing by the water after the first reflow should be avoided.	VP15-00-2
Wave soldering	Solder bath temperature : 260 °C max., Duration : 10 sec. max., Number of times : 1 Pre-heating temperature : 120 °C max. (package surface temperature)	WS60-00-1
Pin part heating	Pin temperature : 300 °C max., Duration: 3 sec. max. (per device side)	—

**Caution Do not use two or more soldering methods in combination (except the pin part heating method).**

- (2) μPD78C10AL : 68-pin plastic QFJ (□ 950 mil)
- μPD78C11AL-xxx : 68-pin plastic QFJ (□ 950 mil)
- μPD78C12AL-xxx : 68-pin plastic QFJ (□ 950 mil)

Soldering Method	Soldering Conditions	Recommended Condition Symbol
Infrared reflow	Package peak temperature : 230 °C, Duration : 30 sec. max. (210 °C min.), Number of times : 1	IR30-00-1
VPS	Package peak temperature : 215 °C, Duration : 40 sec. max. (200 °C min.), Number of times : 1	VP15-00-1
Pin part heating	Pin temperature : 300 °C max., Duration : 3 sec. max. (per device side)	—

**Caution Do not use two or more soldering methods in combination (except the pin part heating method).**

**Table 10-2 Inserted Type Soldering Conditions**

- (1) μPD78C10ACW : 64-pin plastic shrink DIP (750 mil)
- μPD78C11ACW-xxx : 64-pin plastic shrink DIP (750 mil)
- μPD78C12ACW-xxx : 64-pin plastic shrink DIP (750 mil)
- μPD78C10AGQ-36 : 64-pin plastic QUIP
- μPD78C11AGQ-xxx-36 : 64-pin plastic QUIP
- μPD78C12AGQ-xxx-36 : 64-pin plastic QUIP

Soldering Method	Soldering Conditions
Wave soldering (pin only)	Solder bath temperature: 260 °C max. Duration: 10 sec. max.
Pin part heating	Pin temperature: 300 °C max. Duration: 3 sec. max. (per pin)

**Caution** Ensure that the application of wave soldering is limited to the pins and no solder touches the main unit directly.

- (2) μPD78C11AGQ-xxx-37 : 64-pin plastic QUIP straight
- μPD78C12AGQ-xxx-37 : 64-pin plastic QUIP straight

Soldering Method	Soldering Conditions
Pin part heating	Pin temperature: 300 °C max. Duration: 3 sec. max. (per pin)

APPENDIX DEVELOPMENT TOOLS



The following development tools are available to develop a system which uses 87AD series products.

Language Processor

87AD series relocatable assembler (RA87)	This is a program which converts a program written in mnemonic to an object code that micro-computer execution is possible. Besides, it contains a function to automatically create a symbol/table, and optimize a branch instruction.			
	Host Machine	OS	Supply Medium	Ordering Code (Product Name)
	PC-9800 series	MS-DOS™ Ver. 2.11 to Ver. 5.00A*	3.5-inch 2HD	μS5A13RA87
			5-inch 2HD	μS5A10RA87
	IBM PC/AT™	PC DOS™ (Ver. 3.1)	3.5-inch 2HC	μS7B13RA87
5-inch 2HC			μS7B10RA87	

PROM Write Tools

Hardware	PG-1500	With an provided board and an optional programmer adapter connected, this PROM programmer can manipulate from a stand-alone or host machine to perform programming on single-chip microcomputer which incorporates PROM. It is also capable of programming a typical PROM ranging from 256K to 4M bits.			
	PA-78CP14CW/ GF/GQ/KB/L	PROM programmer adapter for μPD78CP14/78CP18. Used by connecting to PG-1500.			
	PA-78CP14CW	For μPD78CP14CW, 78CP14DW, 78CP18CW, 78CP18DW			
	PA-78CP14GF	For μPD78CP14GF-3BE, 78CP18GF-3BE			
	PA-78CP14GQ	For μPD78CP14G-36, 78CP14R, 78CP18GQ-36			
	PA-78CP14KB	For μPD78CP14KB, 78CP18KB			
	PA-78CP14L	For μPD78CP14L			
Software	PG-1500 controller	Connected PG-1500 to a host machine by using serial and parallel interface, to control the PG-1500 on a host machine.			
		Host Machine	OS	Supply Medium	Ordering Code (Product Name)
		PC-9800 series	MS-DOS Ver. 2.11 to Ver. 5.00A*	3.5-inch 2HD	μS5A13PG1500
				5-inch 2HD	μS5A10PG1500
		IBM PC/AT	PC DOS (Ver. 3.1)	5-inch 2HC	μS7B10PG1500

\* Ver. 5.00/5.00A has a task swap function, but this function cannot be used with this software.

**Remarks** Operation of assemblers and the PG-1500 controller are guaranteed only on the host machines and operating systems quoted above.

**Debugging tools**

An in-circuit emulator (IE-78C11-M) is available as a program debugging tool for 87AD series. The following table shows its system configuration.

Hardware	IE-78C11-M	The IE-78C11-M is an in-circuit emulator which works with 87AD series. Only the IE-78C11-M should be used for a plastic QUIP package, while it should be used with a conversion socket for a plastic shrink DIP package. It can be connected to a host machine to perform efficient debugging.			
	EV-9001-64	Conversion sockets for plastic shrink DIP. Used in combination with the IE-78C11-M.			
	EV-9200G-64	64-pin LCC socket. Can be used as a substitute for 64-pin plastic QFP products with window in combination with the μPD78CP14KB/78CP18KB.			
Software	IE-78C11-M control program (IE controller)	Connects the IE-78C11-M to host machine by using the RS-232-C, then controls the IE-78C11-M on host machine.			
		Host Machine	OS	Supply Medium	Ordering Code (Product Name)
		PC-9800 series	MS-DOS Ver. 2.11 to Ver. 3.30D	3.5-inch 2HD	μS5A13IE78C11
				5-inch 2HD	μS5A10IE78C11
IBM PC/AT	PC DOS (Ver. 3.1)	5-inch 2HC	μS7B10IE78C11		

**Remarks** Operation of the IE controller is guaranteed only on the host machine and operating systems quoted above.

[MEMO]

## NOTES FOR CMOS DEVICES

### ① PRECAUTION AGAINST ESD FOR SEMICONDUCTORS

**Note:** Strong electric field, when exposed to a MOS device, can cause destruction of the gate oxide and ultimately degrade the device operation. Steps must be taken to stop generation of static electricity as much as possible, and quickly dissipate it once, when it has occurred. Environmental control must be adequate. When it is dry, humidifier should be used. It is recommended to avoid using insulators that easily build static electricity. Semiconductor devices must be stored and transported in an anti-static container, static shielding bag or conductive material. All test and measurement tools including work bench and floor should be grounded. The operator should be grounded using wrist strap. Semiconductor devices must not be touched with bare hands. Similar precautions need to be taken for PW boards with semiconductor devices on it.

### ② HANDLING OF UNUSED INPUT PINS FOR CMOS

**Note:** No connection for CMOS device inputs can be cause of malfunction. If no connection is provided to the input pins, it is possible that an internal input level may be generated due to noise, etc., hence causing malfunction. CMOS device behave differently than Bipolar or NMOS devices. Input levels of CMOS devices must be fixed high or low by using a pull-up or pull-down circuitry. Each unused pin should be connected to V<sub>DD</sub> or GND with a resistor, if it is considered to have a possibility of being an output pin. All handling related to the unused pins must be judged device by device and related specifications governing the devices.

### ③ STATUS BEFORE INITIALIZATION OF MOS DEVICES

**Note:** Power-on does not necessarily define initial status of MOS device. Production process of MOS does not define the initial operation status of the device. Immediately after the power source is turned ON, the devices with reset function have not yet been initialized. Hence, power-on does not guarantee out-pin levels, I/O settings or contents of registers. Device is not initialized until the reset signal is received. Reset operation must be executed immediately after power-on for devices having reset function.

The export of these products from Japan is regulated by the Japanese government. The export of some or all of these products may be prohibited without governmental license. To export or re-export some or all of these products from a country other than Japan may also be prohibited without a license from that country. Please call an NEC sales representative.

The customer must judge : μPD78C11ACW-xxx, 78C11AGF-xxx-3BE, 78C11AGQ-xxx-36, 78C11AGQ-xxx-37,  
the need for license      μPD78C11AL-xxx, 78C12ACW-xxx, 78C12AGF-xxx-3BE, 78C12AGQ-xxx-36,  
                                         μPD78C12AGQ-xxx-37, 78C12AL-xxx

License not needed :      μPD78C10ACW, 78C10AGF-3BE, 78C10AGQ-36, 78C10AL

No part of this document may be copied or reproduced in any form or by any means without the prior written consent of NEC Corporation. NEC Corporation assumes no responsibility for any errors which may appear in this document.

NEC Corporation does not assume any liability for infringement of patents, copyrights or other intellectual property rights of third parties by or arising from use of a device described herein or any other liability arising from use of such device. No license, either express, implied or otherwise, is granted under any patents, copyrights or other intellectual property rights of NEC Corporation or others.

While NEC Corporation has been making continuous effort to enhance the reliability of its semiconductor devices, the possibility of defects cannot be eliminated entirely. To minimize risks of damage or injury to persons or property arising from a defect in an NEC semiconductor device, customer must incorporate sufficient safety measures in its design, such as redundancy, fire-containment, and anti-failure features.

NEC devices are classified into the following three quality grades:

“Standard”, “Special”, and “Specific”. The Specific quality grade applies only to devices developed based on a customer designated “quality assurance program” for a specific application. The recommended applications of a device depend on its quality grade, as indicated below. Customers must check the quality grade of each device before using it in a particular application.

Standard: Computers, office equipment, communications equipment, test and measurement equipment, audio and visual equipment, home electronic appliances, machine tools, personal electronic equipment and industrial robots

Special: Transportation equipment (automobiles, trains, ships, etc.), traffic control systems, anti-disaster systems, anti-crime systems, safety equipment and medical equipment (not specifically designed for life support)

Specific: Aircrafts, aerospace equipment, submersible repeaters, nuclear reactor control systems, life support systems or medical equipment for life support, etc.

The quality grade of NEC devices in “Standard” unless otherwise specified in NEC's Data Sheets or Data Books. If customers intend to use NEC devices for applications other than those specified for Standard quality grade, they should contact NEC Sales Representative in advance.

Anti-radioactive design is not implemented in this product.