

Features

- Fast Read Access Time – 45 ns
- Low-Power CMOS Operation
 - 100 μ A Max Standby
 - 20 mA Max Active at 5 MHz
- JEDEC Standard Packages
 - 28-lead PDIP
 - 32-lead PLCC
 - 28-lead TSOP and SOIC
- 5V \pm 10% Supply
- High-Reliability CMOS Technology
 - 2,000V ESD Protection
 - 200 mA Latchup Immunity
- Rapid Programming Algorithm – 100 μ s/Byte (Typical)
- CMOS and TTL Compatible Inputs and Outputs
- Integrated Product Identification Code
- Industrial and Automotive Temperature Ranges
- Green (Pb/Halide-free) Packaging Option

勝特力材料 886-3-5753170
勝特力电子(上海) 86-21-34970699
勝特力电子(深圳) 86-755-83298787
[Http://www.100y.com.tw](http://www.100y.com.tw)



**512K (64K x 8)
OTP EPROM**

AT27C512R

1. Description

The AT27C512R is a low-power, high-performance 524,288-bit one-time programmable read-only memory (OTP EPROM) organized 64K by 8 bits. It requires only one 5V power supply in normal read mode operation. Any byte can be accessed in less than 45 ns, eliminating the need for speed reducing WAIT states on high-performance microprocessor systems.

Atmel's scaled CMOS technology provides high-speed, lower active power consumption, and significantly faster programming. Power consumption is typically only 8 mA in Active Mode and less than 10 μ A in Standby.

The AT27C512R is available in a choice of industry-standard JEDEC-approved one-time programmable (OTP) plastic PDIP, PLCC, SOIC, and TSOP packages. All devices feature two-line control (\overline{CE} , \overline{OE}) to give designers the flexibility to prevent bus contention.

With 64K byte storage capability, the AT27C512R allows firmware to be stored reliably and to be accessed by the system without the delays of mass storage media.

Atmel's AT27C512R has additional features to ensure high quality and efficient production use. The Rapid Programming Algorithm reduces the time required to program the part and guarantees reliable programming. Programming time is typically only 100 μ s/byte. The Integrated Product Identification Code electronically identifies the device and manufacturer. This feature is used by industry-standard programming equipment to select the proper programming algorithms and voltages.



2. Pin Configurations

Pin Name	Function
A0 - A15	Addresses
O0 - O7	Outputs
\overline{CE}	Chip Enable
\overline{OE}/VPP	Output Enable/ Program Supply
NC	No Connect

2.1 28-lead PDIP/SOIC Top View

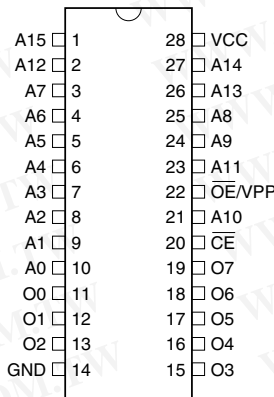

2.3 28-lead TSOP Top View – Type 1

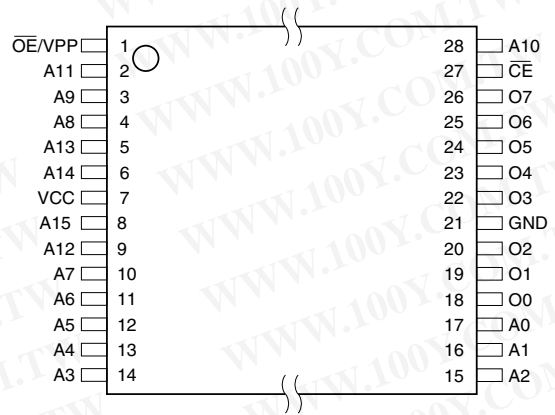

2.2 32-lead PLCC Top View

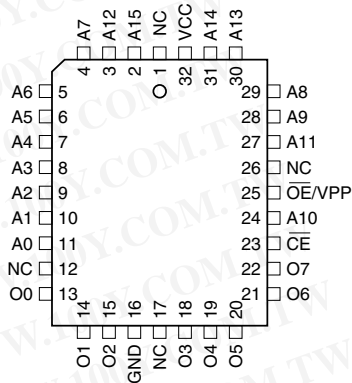

Note: PLCC Package Pins 1 and 17 are Don't Connect.

3. System Considerations

Switching between active and standby conditions via the Chip Enable pin may produce transient voltage excursions. Unless accommodated by the system design, these transients may exceed datasheet limits, resulting in device non-conformance. At a minimum, a 0.1 μF high frequency, low inherent inductance, ceramic capacitor should be utilized for each device. This capacitor should be connected between the V_{CC} and Ground terminals of the device, as close to the device as possible. Additionally, to stabilize the supply voltage level on printed circuit boards with large EPROM arrays, a 4.7 μF bulk electrolytic capacitor should be utilized, again connected between the V_{CC} and Ground terminals. This capacitor should be positioned as close as possible to the point where the power supply is connected to the array.

4. Block Diagram

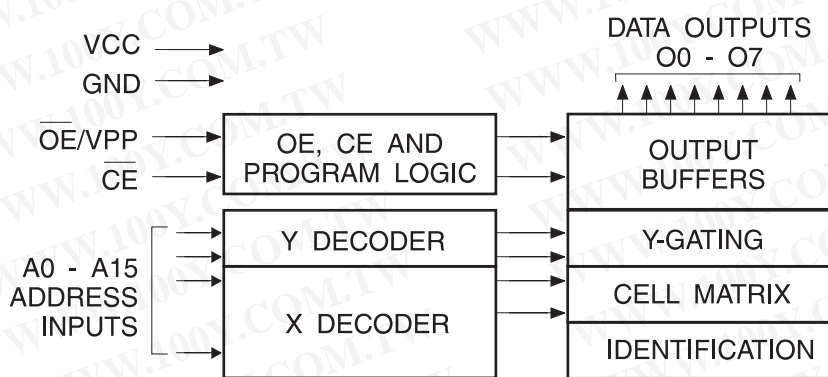

5. Absolute Maximum Ratings*

Temperature Under Bias.....	-55°C to + 125°C
Storage Temperature.....	-65°C to + 150°C
Voltage on Any Pin with Respect to Ground.....	-2.0V to + 7.0V ⁽¹⁾
Voltage on A9 with Respect to Ground.....	-2.0V to + 14.0V ⁽¹⁾
V_{PP} Supply Voltage with Respect to Ground.....	-2.0V to + 14.0V ⁽¹⁾

*NOTICE: Stresses beyond those listed under “Absolute Maximum Ratings” may cause permanent damage to the device. This is a stress rating only and functional operation of the device at these or any other conditions beyond those indicated in the operational sections of this specification is not implied. Exposure to absolute maximum rating conditions for extended periods may affect device reliability.

Note: 1. Minimum voltage is -0.6V DC which may undershoot to -2.0V for pulses of less than 20 ns. Maximum output pin voltage is $V_{CC} + 0.75\text{V}$ DC which may overshoot to +7.0 volts for pulses of less than 20 ns.



6. Operating Modes

Mode/Pin	\overline{CE}	\overline{OE}/V_{PP}	Ai	Outputs
Read	V_{IL}	V_{IL}	Ai	D_{OUT}
Output Disable	V_{IL}	V_{IH}	X ⁽¹⁾	High Z
Standby	V_{IH}	X ⁽¹⁾	X	High Z
Rapid Program ⁽²⁾	V_{IL}	V_{PP}	Ai	D_{IN}
PGM Inhibit	V_{IH}	V_{PP}	X ⁽¹⁾	High Z
Product Identification ⁽⁴⁾	V_{IL}	V_{IL}	A9 = V_H ⁽³⁾ A0 = V_{IH} or V_{IL} A1 - A15 = V_{IL}	Identification Code

Notes: 1. X can be V_{IL} or V_{IH} .

2. Refer to Programming Characteristics.

3. $V_H = 12.0 \pm 0.5V$.

4. Two identifier bytes may be selected. All Ai inputs are held low (V_{IL}), except A9 which is set to V_H and A0 which is toggled low (V_{IL}) to select the Manufacturer's Identification byte and high (V_{IH}) to select the Device Code byte.

7. DC and AC Operating Conditions for Read Operation

		AT27C512R	
		-45	-70
Operating Temp.(Case)	Ind.	-40°C - 85°C	-40°C - 85°C
	Auto.		-40°C - 125°C
V_{CC} Supply		5V \pm 10%	5V \pm 10%

8. DC and Operating Characteristics for Read Operation

Symbol	Parameter	Condition	Min	Max	Units
I_{LI}	Input Load Current	$V_{IN} = 0V$ to V_{CC}	Ind.	± 1	μA
			Auto.	± 5	μA
I_{LO}	Output Leakage Current	$V_{OUT} = 0V$ to V_{CC}	Ind.	± 5	μA
			Auto.	± 10	μA
I_{SB}	V_{CC} ⁽¹⁾ Standby Current	I_{SB1} (CMOS), $\overline{CE} = V_{CC} \pm 0.3V$		100	μA
		I_{SB2} (TTL), $\overline{CE} = 2.0$ to $V_{CC} + 0.5V$		1	mA
I_{CC}	V_{CC} Active Current	$f = 5$ MHz, $I_{OUT} = 0$ mA, $\overline{CE} = V_{IL}$		20	mA
V_{IL}	Input Low Voltage		-0.6	0.8	V
V_{IH}	Input High Voltage		2.0	$V_{CC} + 0.5$	V
V_{OL}	Output Low Voltage	$I_{OL} = 2.1$ mA		0.4	V
V_{OH}	Output High Voltage	$I_{OH} = -400$ μA	2.4		V

Note: 1. V_{CC} must be applied simultaneously with or before \overline{OE}/V_{PP} and removed simultaneously with or after \overline{OE}/V_{PP} .

9. AC Characteristics for Read Operation

Symbol	Parameter	Condition	AT27C512R				Units
			-45		-70		
			Min	Max	Min	Max	
$t_{ACC}^{(1)}$	Address to Output Delay	$\overline{CE} = \overline{OE}/V_{PP} = V_{IL}$		45		70	ns
$t_{CE}^{(1)}$	\overline{CE} to Output Delay	$\overline{OE}/V_{PP} = V_{IL}$		45		70	ns
$t_{OE}^{(1)}$	\overline{OE}/V_{PP} to Output Delay	$\overline{CE} = V_{IL}$		20		30	ns
$t_{DF}^{(1)}$	\overline{OE}/V_{PP} or \overline{CE} High to Output Float, Whichever Occurred First			20		25	ns
t_{OH}	Output Hold from Address, \overline{CE} or \overline{OE}/V_{PP} Whichever Occurred First		7		7		ns

Note: 1. See AC Waveforms for Read Operation.

10. AC Waveforms for Read Operation⁽¹⁾

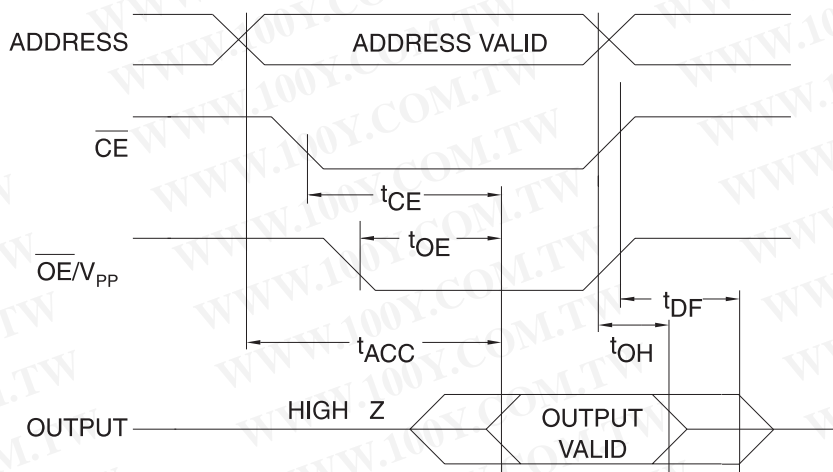

- Notes:
1. Timing measurement reference level is 1.5V for -45 devices. Input AC drive levels are $V_{IL} = 0.0V$ and $V_{IH} = 3.0V$. Timing measurement reference levels for all other speed grades are $V_{OL} = 0.8V$ and $V_{OH} = 2.0V$. Input AC drive levels are $V_{IL} = 0.45V$ and $V_{IH} = 2.4V$.
 2. \overline{OE}/V_{PP} may be delayed up to $t_{CE} - t_{OE}$ after the falling edge of \overline{CE} without impact on t_{CE} .
 3. \overline{OE}/V_{PP} may be delayed up to $t_{ACC} - t_{OE}$ after the address is valid without impact on t_{ACC} .
 4. This parameter is only sampled and is not 100% tested.
 5. Output float is defined as the point when data is no longer driven.

11. Input Test Waveforms and Measurement Levels

For -45 devices only:

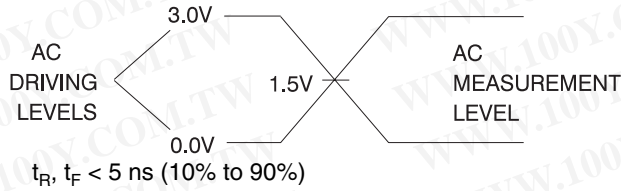

For -70 devices:

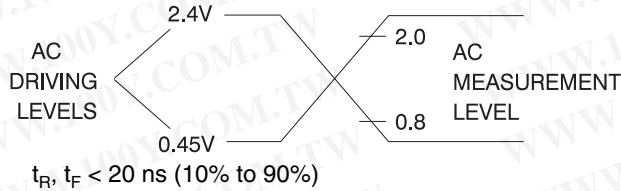

12. Output Test Load

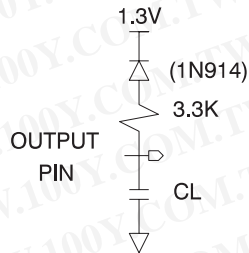

Note: 1. $C_L = 100 \text{ pF}$ including jig capacitance, except for the -45 devices, where $C_L = 30 \text{ pF}$.

13. Pin Capacitance

$f = 1 \text{ MHz}$, $T = 25^\circ\text{C}^{(1)}$

Symbol	Typ	Max	Units	Conditions
C_{IN}	4	6	pF	$V_{IN} = 0V$
C_{OUT}	8	12	pF	$V_{OUT} = 0V$

Note: 1. Typical values for nominal supply voltage. This parameter is only sampled and is not 100% tested.

14. Programming Waveforms⁽¹⁾

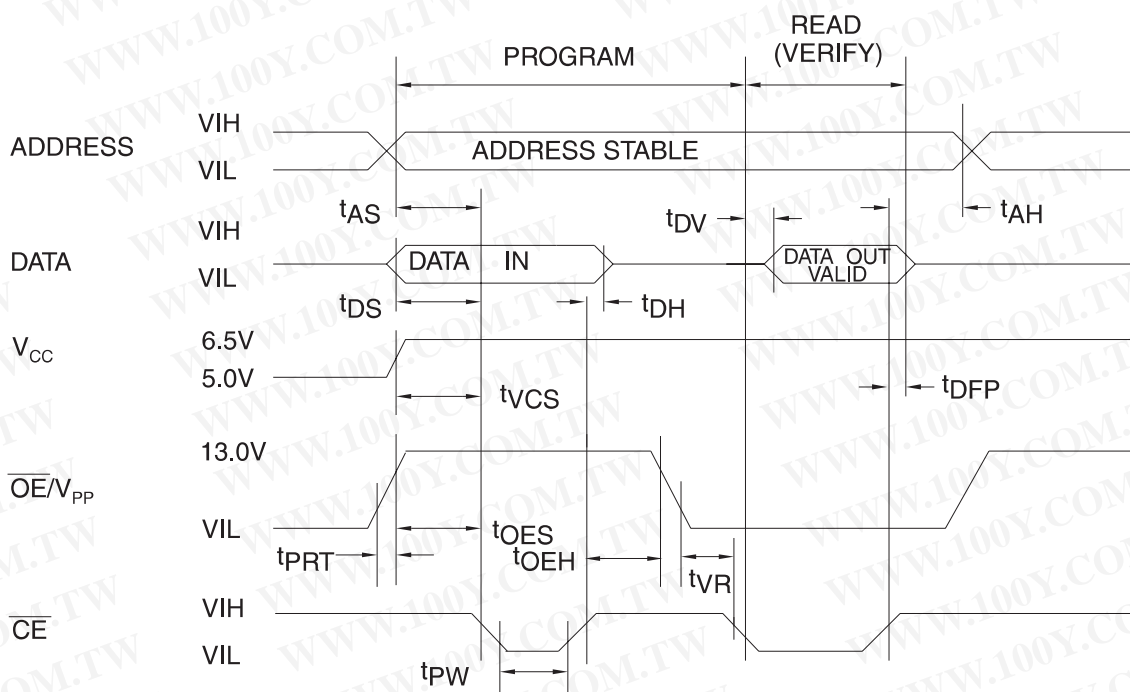

- Notes:
1. The Input Timing Reference is 0.8V for V_{IL} and 2.0V for V_{IH}.
 2. t_{OE} and t_{DFP} are characteristics of the device but must be accommodated by the programmer.

15. DC Programming Characteristics

T_A = 25 ± 5°C, V_{CC} = 6.5 ± 0.25V, OE/V_{PP} = 13.0 ± 0.25V

Symbol	Parameter	Test Conditions	Limits		Units
			Min	Max	
I _{LI}	Input Load Current	V _{IN} = V _{IL} , V _{IH}		±10	μA
V _{IL}	Input Low Level		-0.6	0.8	V
V _{IH}	Input High Level		2.0	V _{CC} + 1	V
V _{OL}	Output Low Voltage	I _{OL} = 2.1 mA		0.4	V
V _{OH}	Output High Voltage	I _{OH} = -400 μA	2.4		V
I _{CC2}	V _{CC} Supply Current (Program and Verify)			25	mA
I _{PP2}	OE/V _{PP} Current	OE = V _{IL}		25	mA
V _{ID}	A9 Product Identification Voltage		11.5	12.5	V



16. AC Programming Characteristics

$T_A = 25 \pm 5^\circ\text{C}$, $V_{CC} = 6.5 \pm 0.25\text{V}$, $\overline{\text{OE}}/V_{PP} = 13.0 \pm 0.25\text{V}$

Symbol	Parameter	Test Conditions ⁽¹⁾	Limits		Units
			Min	Max	
t_{AS}	Address Setup Time	Input Rise and Fall Times (10% to 90%) 20 ns	2		μs
t_{OES}	$\overline{\text{OE}}/V_{PP}$ Setup Time		2		μs
t_{OEH}	$\overline{\text{OE}}/V_{PP}$ Hold Time		2		μs
t_{DS}	Data Setup Time		2		μs
t_{AH}	Address Hold Time	Input Pulse Levels 0.45V to 2.4V	0		μs
t_{DH}	Data Hold Time		2		μs
t_{DFP}	$\overline{\text{CE}}$ High to Output Float Delay ⁽²⁾	Input Timing Reference Level 0.8V to 2.0V	0	130	ns
t_{VCS}	V_{CC} Setup Time		2		μs
t_{PW}	$\overline{\text{CE}}$ Program Pulse Width ⁽³⁾		95	105	μs
t_{DV}	Data Valid from $\overline{\text{CE}}$ ⁽²⁾	Output Timing Reference Level 0.8V to 2.0V		1	μs
t_{VR}	$\overline{\text{OE}}/V_{PP}$ Recovery Time		2		μs
t_{PRT}	$\overline{\text{OE}}/V_{PP}$ Pulse Rise Time During Programming		50		ns

- Notes:
- V_{CC} must be applied simultaneously or before $\overline{\text{OE}}/V_{PP}$ and removed simultaneously or after $\overline{\text{OE}}/V_{PP}$.
 - This parameter is only sampled and is not 100% tested. Output Float is defined as the point where data is no longer driven – see timing diagram.
 - Program Pulse width tolerance is $100 \mu\text{sec} \pm 5\%$.

17. Atmel's AT27C512R Integrated Product Identification Code

Codes	Pins									Hex Data
	A0	O7	O6	O5	O4	O3	O2	O1	O0	
Manufacturer	0	0	0	0	1	1	1	1	0	1E
Device Type	1	0	0	0	0	1	1	0	1	0D

18. Rapid Programming Algorithm

A 100 μs $\overline{\text{CE}}$ pulse width is used to program. The address is set to the first location. V_{CC} is raised to 6.5V and OE/V_{PP} is raised to 13.0V. Each address is first programmed with one 100 μs $\overline{\text{CE}}$ pulse without verification. Then a verification/reprogramming loop is executed for each address. In the event a byte fails to pass verification, up to 10 successive 100 μs pulses are applied with a verification after each pulse. If the byte fails to verify after 10 pulses have been applied, the part is considered failed. After the byte verifies properly, the next address is selected until all have been checked. OE/V_{PP} is then lowered to V_{IL} and V_{CC} to 5.0V. All bytes are read again and compared with the original data to determine if the device passes or fails.

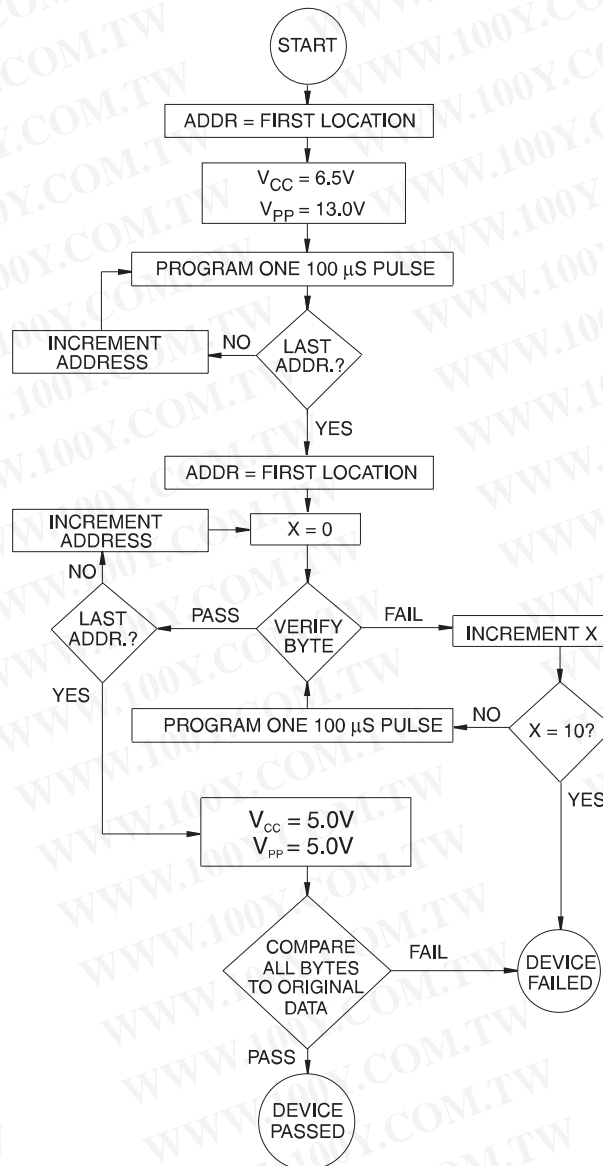



19. Ordering Information

19.1 Standard Package

t _{Acc} (ns)	I _{CC} (mA)		Ordering Code	Package	Operation Range
	Active	Standby			
45	20	0.1	AT27C512R-45JI	32J	Industrial (-40° C to 85° C)
			AT27C512R-45PI	28P6	
			AT27C512R-45RI	28R ⁽¹⁾	
			AT27C512R-45TI	28T	
70	20	0.1	AT27C512R-70JI	32J	Industrial (-40° C to 85° C)
			AT27C512R-70PI	28P6	
			AT27C512R-70RI	28R ⁽¹⁾	
			AT27C512R-70TI	28T	
	20	0.1	AT27C512R-70JA	32J	Automotive (-40° C to 125° C)
			AT27C512R-70PA	28P6	
			AT27C512R-70RA	28R ⁽¹⁾	

Note: Not recommended for new designs. Use Green package option.

19.2 Green Package (Pb/Halide-free)

t _{Acc} (ns)	I _{CC} (mA)		Ordering Code	Package	Operation Range
	Active	Standby			
45	20	0.1	AT27C512R-45JU	32J	Industrial (-40° C to 85° C)
			AT27C512R-45PU	28P6	
			AT27C512R-45RU	28R ⁽¹⁾	
			AT27C512R-45TU	28T	
70	20	0.1	AT27C512R-70JU	32J	Industrial (-40° C to 85° C)
			AT27C512R-70PU	28P6	
			AT27C512R-70RU	28R ⁽¹⁾	
			AT27C512R-70TU	28T	

Note: 1. The 28-pin SOIC package is not recommended for new designs.

Package Type	
32J	32-Lead, Plastic J-Leaded Chip Carrier (PLCC)
28P6	28-Lead, 0.600" Wide, Plastic Dual Inline Package (PDIP)
28R	28-Lead, 0.330" Wide, Plastic Gull Wing Small Outline (SOIC)
28T	28-Lead, Thin Small Outline Package (TSOP)

Packaging Information

19.3 32J – PLCC

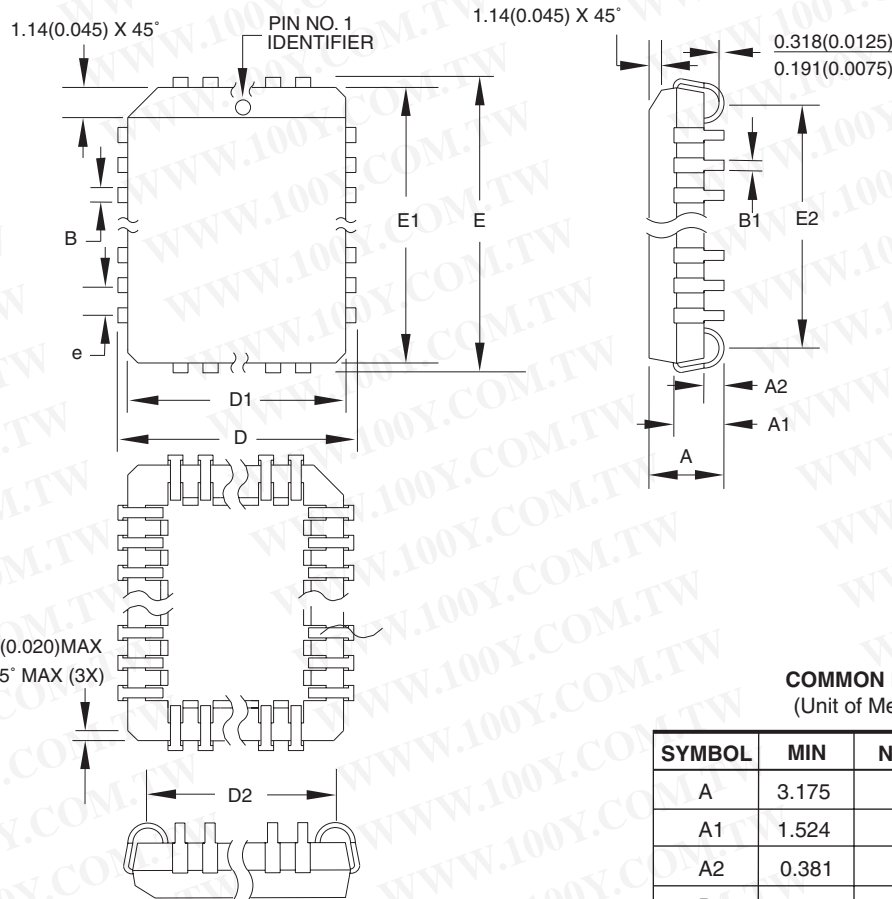

COMMON DIMENSIONS
(Unit of Measure = mm)

SYMBOL	MIN	NOM	MAX	NOTE
A	3.175	-	3.556	
A1	1.524	-	2.413	
A2	0.381	-	-	
D	12.319	-	12.573	
D1	11.354	-	11.506	Note 2
D2	9.906	-	10.922	
E	14.859	-	15.113	
E1	13.894	-	14.046	Note 2
E2	12.471	-	13.487	
B	0.660	-	0.813	
B1	0.330	-	0.533	
e	1.270 TYP			

- Notes:
1. This package conforms to JEDEC reference MS-016, Variation AE.
 2. Dimensions D1 and E1 do not include mold protrusion. Allowable protrusion is .010" (0.254 mm) per side. Dimension D1 and E1 include mold mismatch and are measured at the extreme material condition at the upper or lower parting line.
 3. Lead coplanarity is 0.004" (0.102 mm) maximum.

10/04/01



2325 Orchard Parkway
San Jose, CA 95131

TITLE

32J, 32-lead, Plastic J-leaded Chip Carrier (PLCC)

DRAWING NO.

32J

REV.

B



19.4 28P6 – PDIP

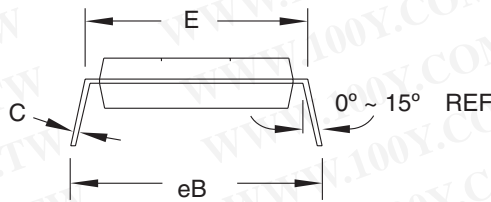
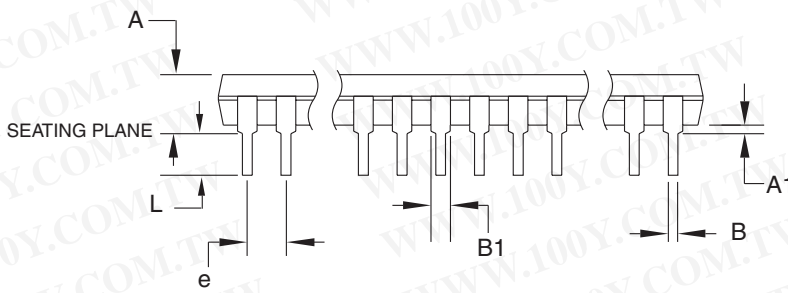
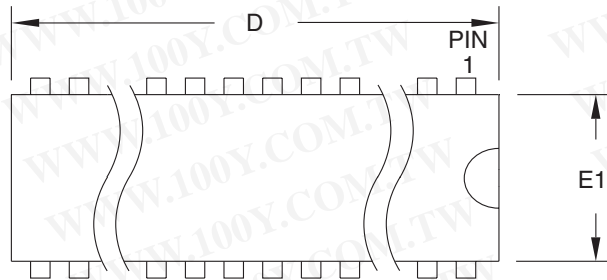

COMMON DIMENSIONS
(Unit of Measure = mm)

SYMBOL	MIN	NOM	MAX	NOTE
A	–	–	4.826	
A1	0.381	–	–	
D	36.703	–	37.338	Note 2
E	15.240	–	15.875	
E1	13.462	–	13.970	Note 2
B	0.356	–	0.559	
B1	1.041	–	1.651	
L	3.048	–	3.556	
C	0.203	–	0.381	
eB	15.494	–	17.526	
e	2.540 TYP			

- Notes:
1. This package conforms to JEDEC reference MS-011, Variation AB.
 2. Dimensions D and E1 do not include mold Flash or Protrusion.
Mold Flash or Protrusion shall not exceed 0.25 mm (0.010").

09/28/01



2325 Orchard Parkway
San Jose, CA 95131

TITLE

28P6, 28-lead (0.600"/15.24 mm Wide) Plastic Dual
Inline Package (PDIP)

DRAWING NO.

28P6

REV.

B

19.5 28R – SOIC

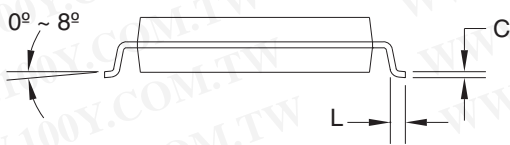
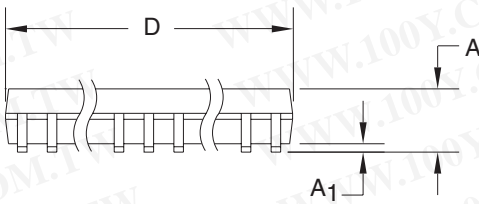
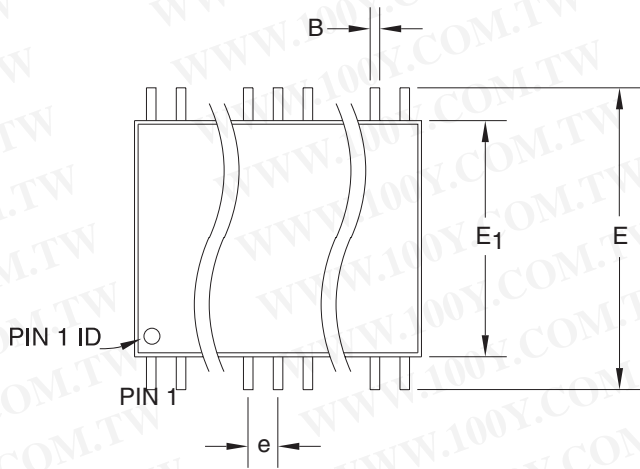

Note: 1. Dimensions D and E1 do not include mold Flash or protrusion. Mold Flash or protrusion shall not exceed 0.25 mm (0.010").

COMMON DIMENSIONS
(Unit of Measure = mm)

SYMBOL	MIN	NOM	MAX	NOTE
A	2.39	–	2.79	
A1	0.050	–	0.356	
D	18.00	–	18.50	Note 1
E	11.70	–	12.50	
E1	8.59	–	8.79	Note 1
B	0.356	–	0.508	
C	0.203	–	0.305	
L	0.94	–	1.27	
e	1.27 TYP			

5/18/2004



2325 Orchard Parkway
San Jose, CA 95131

TITLE

28R, 28-lead, 0.330" Body Width,
Plastic Gull Wing Small Outline (SOIC)

DRAWING NO.

28R

REV.

C



19.6 28T – TSOP

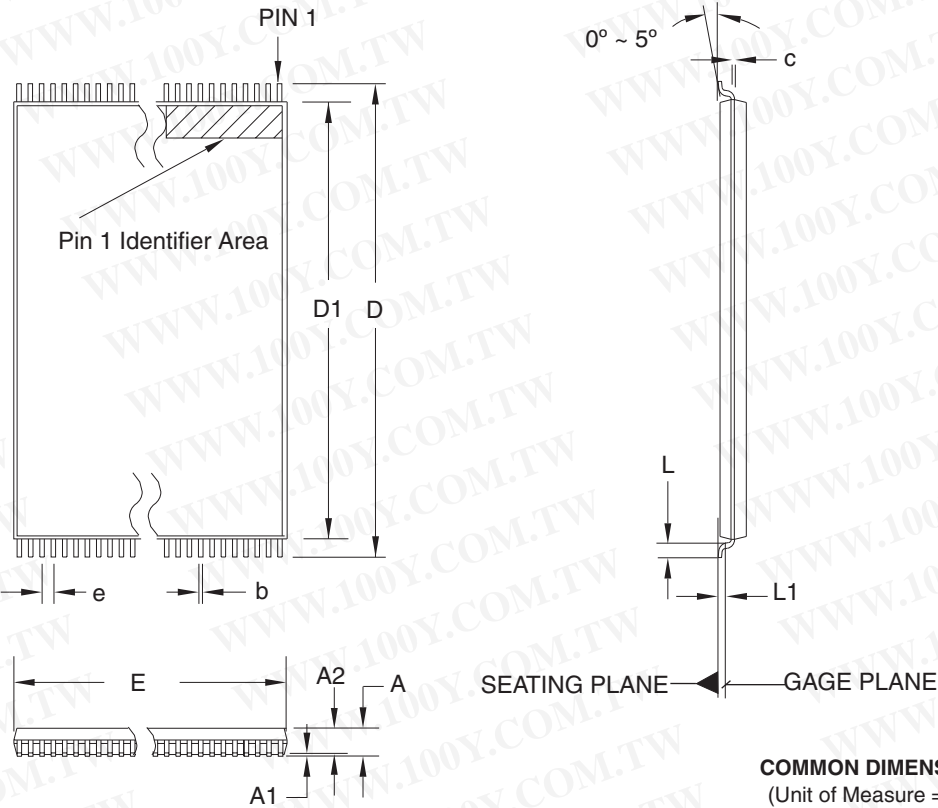

COMMON DIMENSIONS
(Unit of Measure = mm)

SYMBOL	MIN	NOM	MAX	NOTE
A	–	–	1.20	
A1	0.05	–	0.15	
A2	0.90	1.00	1.05	
D	13.20	13.40	13.60	
D1	11.70	11.80	11.90	Note 2
E	7.90	8.00	8.10	Note 2
L	0.50	0.60	0.70	
L1	0.25 BASIC			
b	0.17	0.22	0.27	
c	0.10	–	0.21	
e	0.55 BASIC			

- Notes:
1. This package conforms to JEDEC reference MO-183.
 2. Dimensions D1 and E do not include mold protrusion. Allowable protrusion on E is 0.15 mm per side and on D1 is 0.25 mm per side.
 3. Lead coplanarity is 0.10 mm maximum.

12/06/02



2325 Orchard Parkway
San Jose, CA 95131

TITLE

28T, 28-lead (8 x 13.4 mm) Plastic Thin Small Outline Package, Type I (TSOP)

DRAWING NO.

28T

REV.

C