

# TLE202x, TLE202xA, TLE202xB, TLE202xY EXCALIBUR HIGH-SPEED LOW-POWER PRECISION OPERATIONAL AMPLIFIERS

SLOS191 – FEBRUARY 1997

- Supply Current . . . 230  $\mu$ A Max
- High Unity-Gain Bandwidth . . . 2 MHz Typ
- High Slew Rate . . . 0.45 V/ $\mu$ s Min
- Supply-Current Change Over Military Temp Range . . . 10  $\mu$ A Typ at  $V_{CC} \pm = \pm 15$  V
- Specified for Both 5-V Single-Supply and  $\pm 15$ -V Operation
- Phase-Reversal Protection
- High Open-Loop Gain . . . 6.5 V/ $\mu$ V (136 dB) Typ
- Low Offset Voltage . . . 100  $\mu$ V Max
- Offset Voltage Drift With Time 0.005  $\mu$ V/mo Typ
- Low Input Bias Current . . . 50 nA Max
- Low Noise Voltage . . . 19 nV/ $\sqrt{\text{Hz}}$  Typ

## description

The TLE202x, TLE202xA, and TLE202xB devices are precision, high-speed, low-power operational amplifiers using a new Texas Instruments Excalibur process. These devices combine the best features of the OP21 with highly improved slew rate and unity-gain bandwidth.

The complementary bipolar Excalibur process utilizes isolated vertical pnp transistors that yield dramatic improvement in unity-gain bandwidth and slew rate over similar devices.

The addition of a bias circuit in conjunction with this process results in extremely stable parameters with both time and temperature. This means that a precision device remains a precision device even with changes in temperature and over years of use.

This combination of excellent dc performance with a common-mode input voltage range that includes the negative rail makes these devices the ideal choice for low-level signal conditioning applications in either single-supply or split-supply configurations. In addition, these devices offer phase-reversal protection circuitry that eliminates an unexpected change in output states when one of the inputs goes below the negative supply rail.

A variety of available options includes small-outline and chip-carrier versions for high-density systems applications.

The C-suffix devices are characterized for operation from 0°C to 70°C. The I-suffix devices are characterized for operation from –40°C to 85°C. The M-suffix devices are characterized for operation over the full military temperature range of –55°C to 125°C.

勝特力材料 886-3-5753170  
勝特力电子(上海) 86-21-34970699  
勝特力电子(深圳) 86-755-83298787  
[Http://www.100y.com.tw](http://www.100y.com.tw)



Please be aware that an important notice concerning availability, standard warranty, and use in critical applications of Texas Instruments semiconductor products and disclaimers thereto appears at the end of this data sheet.

PRODUCTION DATA information is current as of publication date. Products conform to specifications per the terms of Texas Instruments standard warranty. Production processing does not necessarily include testing of all parameters.

 **TEXAS  
INSTRUMENTS**

POST OFFICE BOX 655303 • DALLAS, TEXAS 75265

Copyright © 1997, Texas Instruments Incorporated

# TLE202x, TLE202xA, TLE202xB, TLE202xY EXCALIBUR HIGH-SPEED LOW-POWER PRECISION OPERATIONAL AMPLIFIERS

SLOS191 – FEBRUARY 1997

勝特力材料 886-3-5753170  
勝特力电子(上海) 86-21-34970699  
勝特力电子(深圳) 86-755-83298787  
[Http://www.100y.com.tw](http://www.100y.com.tw)

## TLE2021 AVAILABLE OPTIONS

| T <sub>A</sub>       | V <sub>IOmax</sub><br>AT 25°C | PACKAGED DEVICES             |               |  |  |                              |                   | CHIP<br>FORMS <sup>§</sup><br>(Y) |
|----------------------|-------------------------------|------------------------------|---------------|--|--|------------------------------|-------------------|-----------------------------------|
|                      |                               | SMALL<br>OUTLINE†<br>(D)     | SSOP‡<br>(DB) | CHIP<br>CARRIER<br>(FK)                  | CERAMIC DIP<br>(JG)                      | PLASTIC DIP<br>(P)           | TSSOP‡<br>(PW)    |                                   |
| 0°C to<br>70°C       | 200 µV<br>500 µV              | TLE2021ACD<br>TLE2021CD      | TLE2021CDBLE  | —  | —  | TLE2021ACP<br>TLE2021CP      | —<br>TLE2021CPWLE | —<br>TLE2021Y                     |
| -40°C<br>to<br>85°C  | 200 µV<br>500 µV              | TLE2021AID<br>TLE2021ID      | —             | —  | —  | TLE2021AIP<br>TLE2021IP      | —                 | —                                 |
| -55°C<br>to<br>125°C | 100 µV<br>200 µV<br>500 µV    | —<br>TLE2021AMD<br>TLE2021MD | —             | TLE2021BMFK<br>TLE2021AMFK<br>TLE2021MFK | TLE2021BMJG<br>TLE2021AMJG<br>TLE2021MJG | —<br>TLE2021AMP<br>TLE2021MP | —                 | —                                 |

† The D packages are available taped and reeled. To order a taped and reeled part, add the suffix R (e.g., TLE2021CDR).

‡ The DB and PW packages are only available left-end taped and reeled.

§ Chip forms are tested at 25°C only.

## TLE2022 AVAILABLE OPTIONS

| T <sub>A</sub>       | V <sub>IOmax</sub><br>AT 25°C | PACKAGED DEVICES                      |                        |                                |  |                              |                        | CHIP<br>FORMS <sup>§</sup><br>(Y) |
|----------------------|-------------------------------|---------------------------------------|------------------------|--------------------------------|--|------------------------------|------------------------|-----------------------------------|
|                      |                               | SMALL<br>OUTLINE†<br>(D)              | SSOP‡<br>(DB)          | CHIP<br>CARRIER<br>(FK)        | CERAMIC<br>DIP<br>(JG)                   | PLASTIC<br>DIP<br>(P)        | TSSOP‡<br>(PW)         |                                   |
| 0°C<br>to<br>70°C    | 150 µV<br>300 µV<br>500 µV    | TLE2022BCD<br>TLE2022ACD<br>TLE2022CD | —<br>—<br>TLE2022CDBLE | —                              | —  | —<br>TLE2022ACP<br>TLE2022CP | —<br>—<br>TLE2022CPWLE | —<br>—<br>TLE2022Y                |
| -40°C<br>to<br>85°C  | 150 µV<br>300 µV<br>500 µV    | TLE2022BID<br>TLE2022AID<br>TLE2022ID | —                      | —                              | —  | —<br>TLE2022AIP<br>TLE2022IP | —                      | —                                 |
| -55°C<br>to<br>125°C | 150 µV<br>300 µV<br>500 µV    | —<br>TLE2022AMD<br>TLE2022MD          | —                      | —<br>TLE2022AMFK<br>TLE2022MFK | TLE2022BMJG<br>TLE2022AMJG<br>TLE2022MJG | —<br>TLE2022AMP<br>TLE2022MP | —                      | —                                 |

† The D packages are available taped and reeled. To order a taped and reeled part, add the suffix R (e.g., TLE2022CDR).

‡ The DB and PW packages are only available left-end taped and reeled.

§ Chip forms are tested at 25°C only.

## TLE2024 AVAILABLE OPTIONS

| T <sub>A</sub> | V <sub>IOmax</sub><br>AT 25°C | PACKAGED DEVICES                         |  |                                       |                                       | CHIP<br>FORM†<br>(Y) |
|----------------|-------------------------------|--|--|---------------------------------------|---------------------------------------|----------------------|
|                |                               | SMALL<br>OUTLINE<br>(DW)                 | CHIP<br>CARRIER<br>(FK)                  | CERAMIC<br>DIP<br>(J)                 | PLASTIC<br>DIP<br>(N)                 |                      |
| 0°C to 70°C    | 500 µV<br>750 µV<br>1000 µV   | TLE2024BCDW<br>TLE2024ACDW<br>TLE2024CDW | —  | —                                     | TLE2024BCN<br>TLE2024ACN<br>TLE2024CN | —<br>—<br>TLE2024Y   |
| -40°C to 85°C  | 500 µV<br>750 µV<br>1000 µV   | TLE2024BIDW<br>TLE2024AIDW<br>TLE2024IDW | —  | —                                     | TLE2024BIN<br>TLE2024AIN<br>TLE2024IN | —                    |
| -55°C to 125°C | 500 µV<br>750 µV<br>1000 µV   | TLE2024BMDW<br>TLE2024AMDW<br>TLE2024MDW | TLE2024BMFK<br>TLE2024AMFK<br>TLE2024MFK | TLE2024BMJ<br>TLE2024AMJ<br>TLE2024MJ | TLE2024BMN<br>TLE2024AMN<br>TLE2024MN | —                    |

† Chip forms are tested at 25°C only.



POST OFFICE BOX 655303 • DALLAS, TEXAS 75265

# TLE202x, TLE202xA, TLE202xB, TLE202xY EXCALIBUR HIGH-SPEED LOW-POWER PRECISION OPERATIONAL AMPLIFIERS

SLOS191 – FEBRUARY 1997

description (continued)

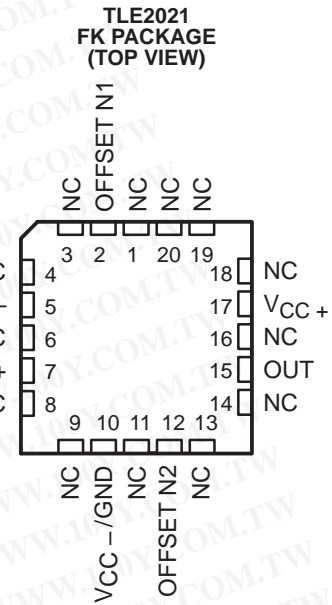
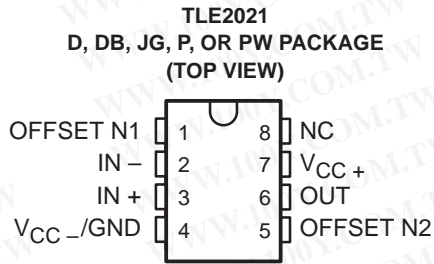

NC – No internal connection

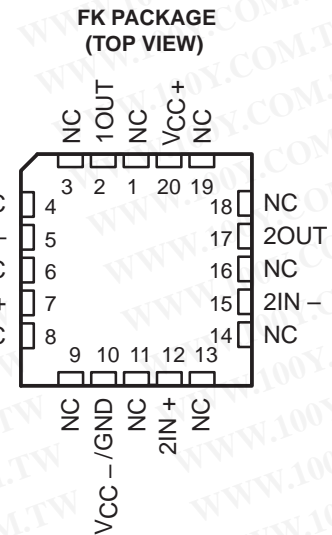
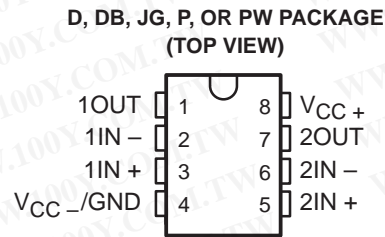

NC – No internal connection

勝特力材料 886-3-5753170  
勝特力电子(上海) 86-21-34970699  
勝特力电子(深圳) 86-755-83298787  
[Http://www.100y.com.tw](http://www.100y.com.tw)

# TLE202x, TLE202xA, TLE202xB, TLE202xY EXCALIBUR HIGH-SPEED LOW-POWER PRECISION OPERATIONAL AMPLIFIERS

SLOS191 – FEBRUARY 1997

**DW PACKAGE  
(TOP VIEW)**

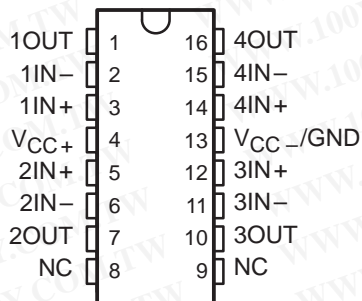

**FK PACKAGE  
(TOP VIEW)**

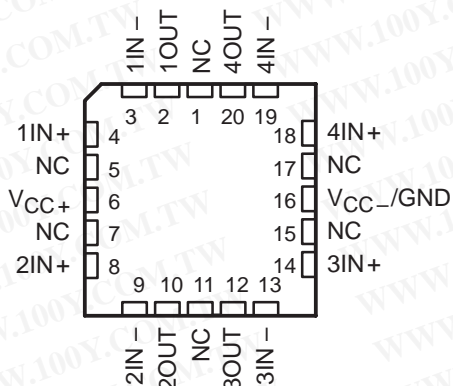

**J OR N PACKAGE  
(TOP VIEW)**

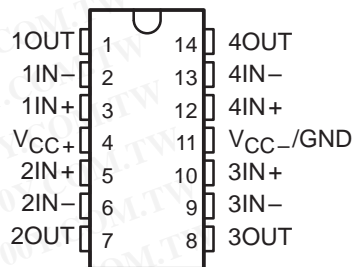

NC – No internal connection

勝特力材料 86-3-5753170  
 勝特力电子(上海) 86-21-34970699  
 勝特力电子(深圳) 86-755-83298787  
[Http://www.100y.com.tw](http://www.100y.com.tw)

# TLE202x, TLE202xA, TLE202xB, TLE202xY EXCALIBUR HIGH-SPEED LOW-POWER PRECISION OPERATIONAL AMPLIFIERS

SLOS191 – FEBRUARY 1997

## TLE2021Y chip information

This chip, when properly assembled, display characteristics similar to the TLE2021. Thermal compression or ultrasonic bonding may be used on the doped-aluminum bonding pads. This chip may be mounted with conductive epoxy or a gold-silicon preform.

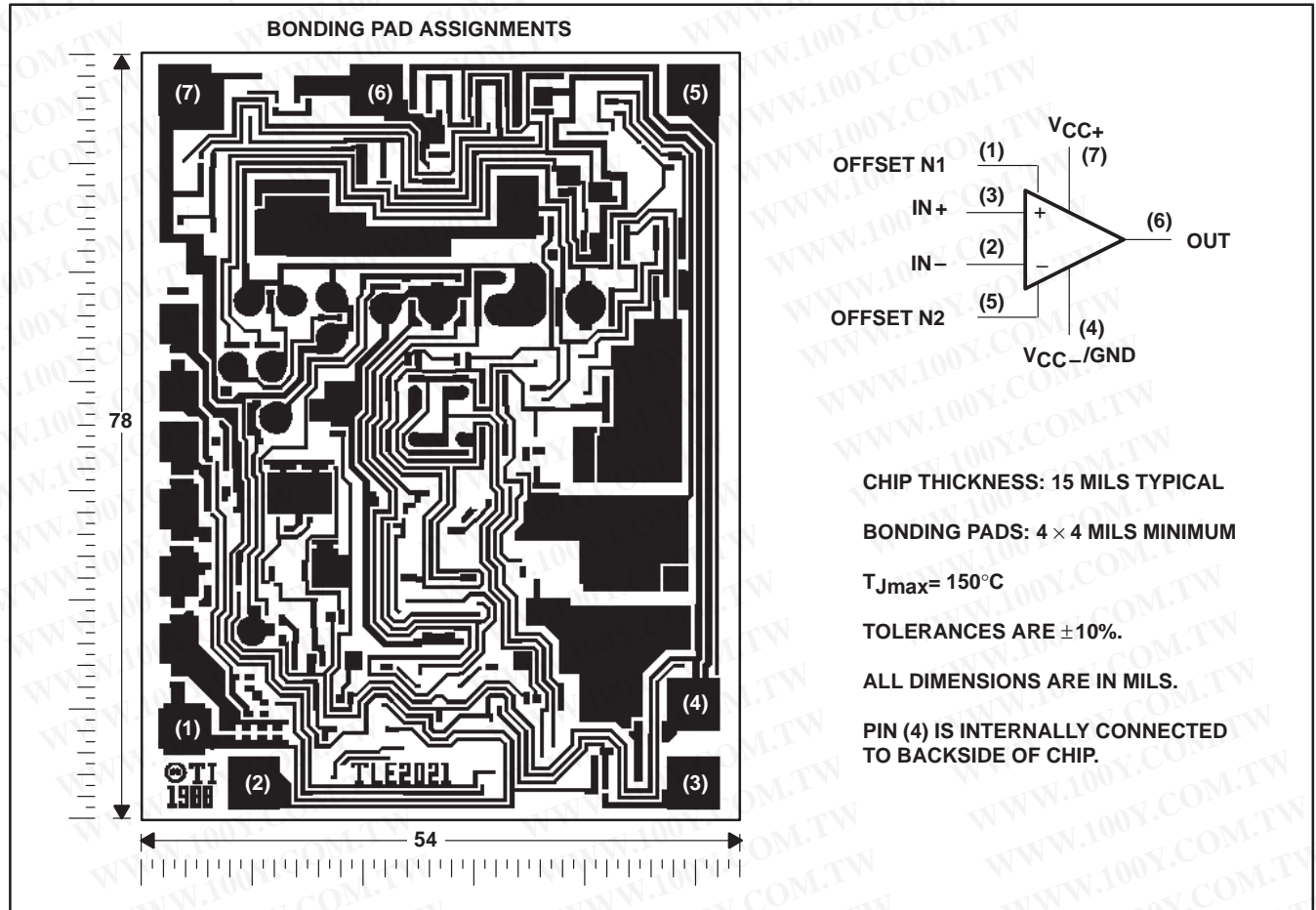

勝特力材料 886-3-5753170  
 勝特力电子(上海) 86-21-34970699  
 勝特力电子(深圳) 86-755-83298787  
[Http://www.100y.com.tw](http://www.100y.com.tw)

# TLE202x, TLE202xA, TLE202xB, TLE202xY EXCALIBUR HIGH-SPEED LOW-POWER PRECISION OPERATIONAL AMPLIFIERS

SLOS191 – FEBRUARY 1997

## TLE2022Y chip information

This chip, when properly assembled, displays characteristics similar to TLE2022. Thermal compression or ultrasonic bonding may be used on the doped-aluminum bonding pads. This chip may be mounted with conductive epoxy or a gold-silicon preform.

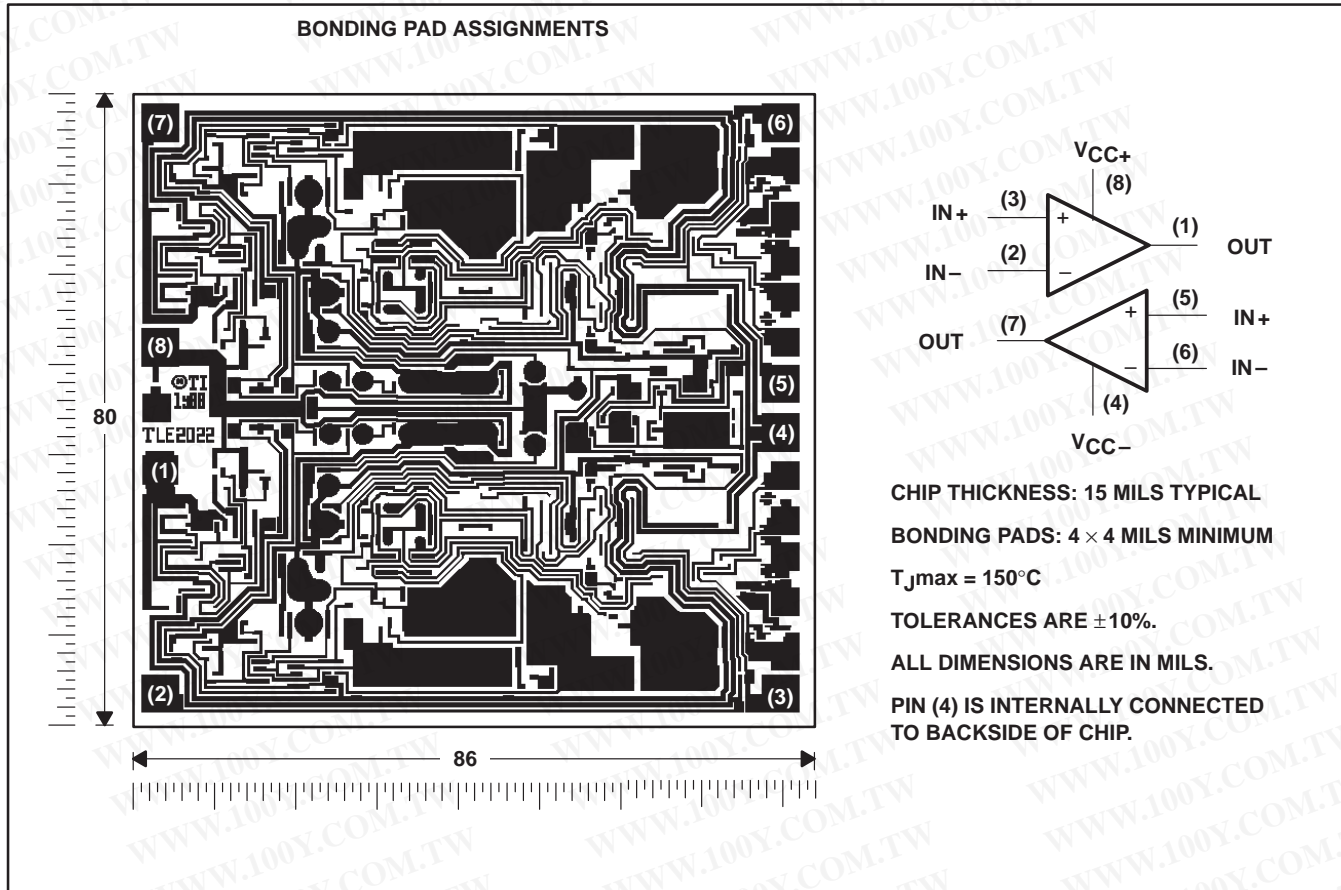

勝特力材料 886-3-5753170  
 勝特力电子(上海) 86-21-34970699  
 勝特力电子(深圳) 86-755-83298787  
[Http://www.100y.com.tw](http://www.100y.com.tw)

# TLE202x, TLE202xA, TLE202xB, TLE202xY EXCALIBUR HIGH-SPEED LOW-POWER PRECISION OPERATIONAL AMPLIFIERS

SLOS191 – FEBRUARY 1997

## TLE2024Y chip information

This chip, when properly assembled, displays characteristics similar to the TLE2024. Thermal compression or ultrasonic bonding may be used on the doped aluminum-bonding pads. This chip may be mounted with conductive epoxy or a gold-silicon preform.

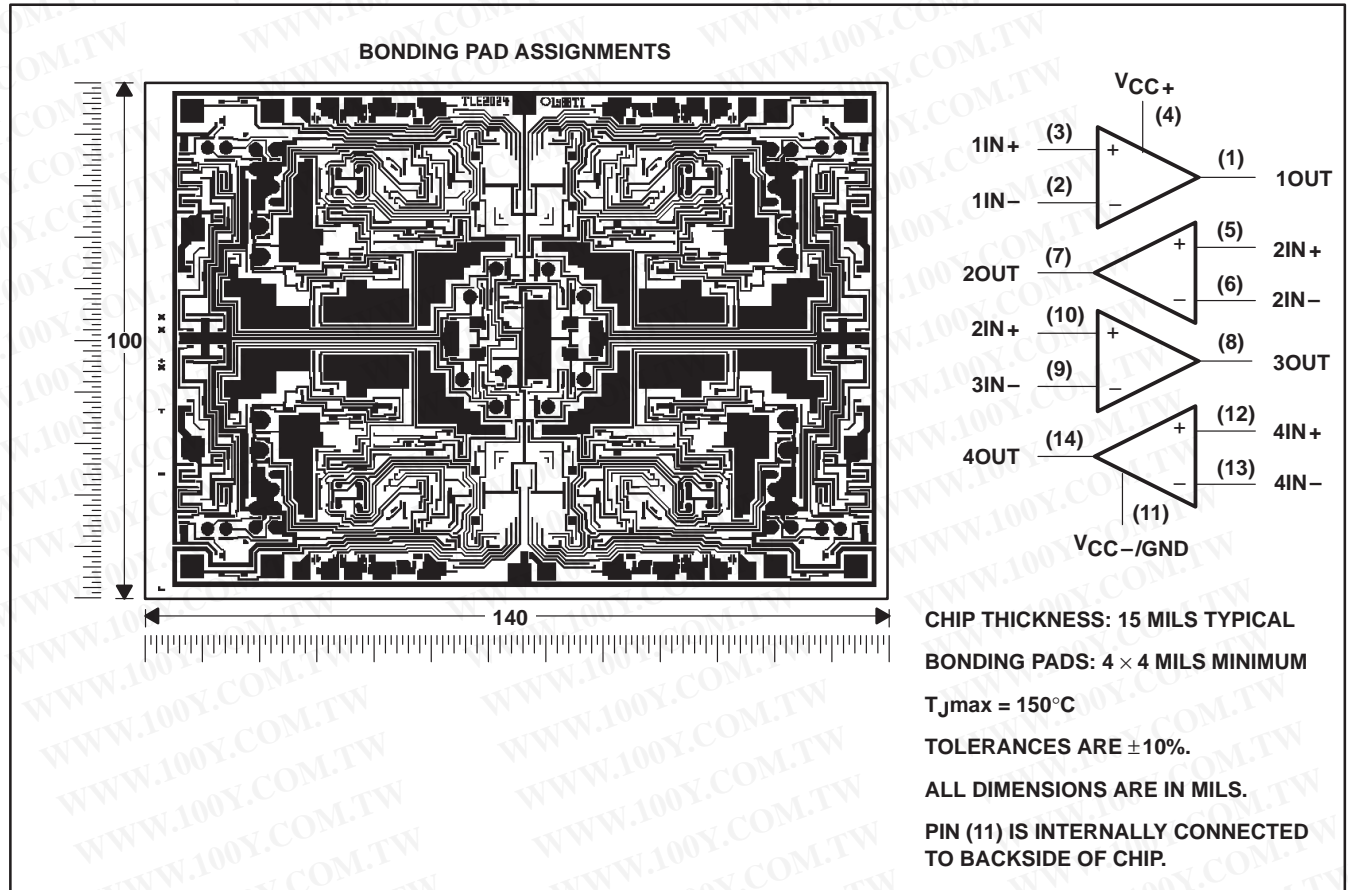

勝特力材料 886-3-5753170  
 勝特力电子(上海) 86-21-34970699  
 勝特力电子(深圳) 86-755-83298787  
[Http://www.100y.com.tw](http://www.100y.com.tw)

# TLE202x, TLE202xA, TLE202xB, TLE202xY EXCALIBUR HIGH-SPEED LOW-POWER PRECISION OPERATIONAL AMPLIFIERS

SLOS191 – FEBRUARY 1997

equivalent schematic (each amplifier)

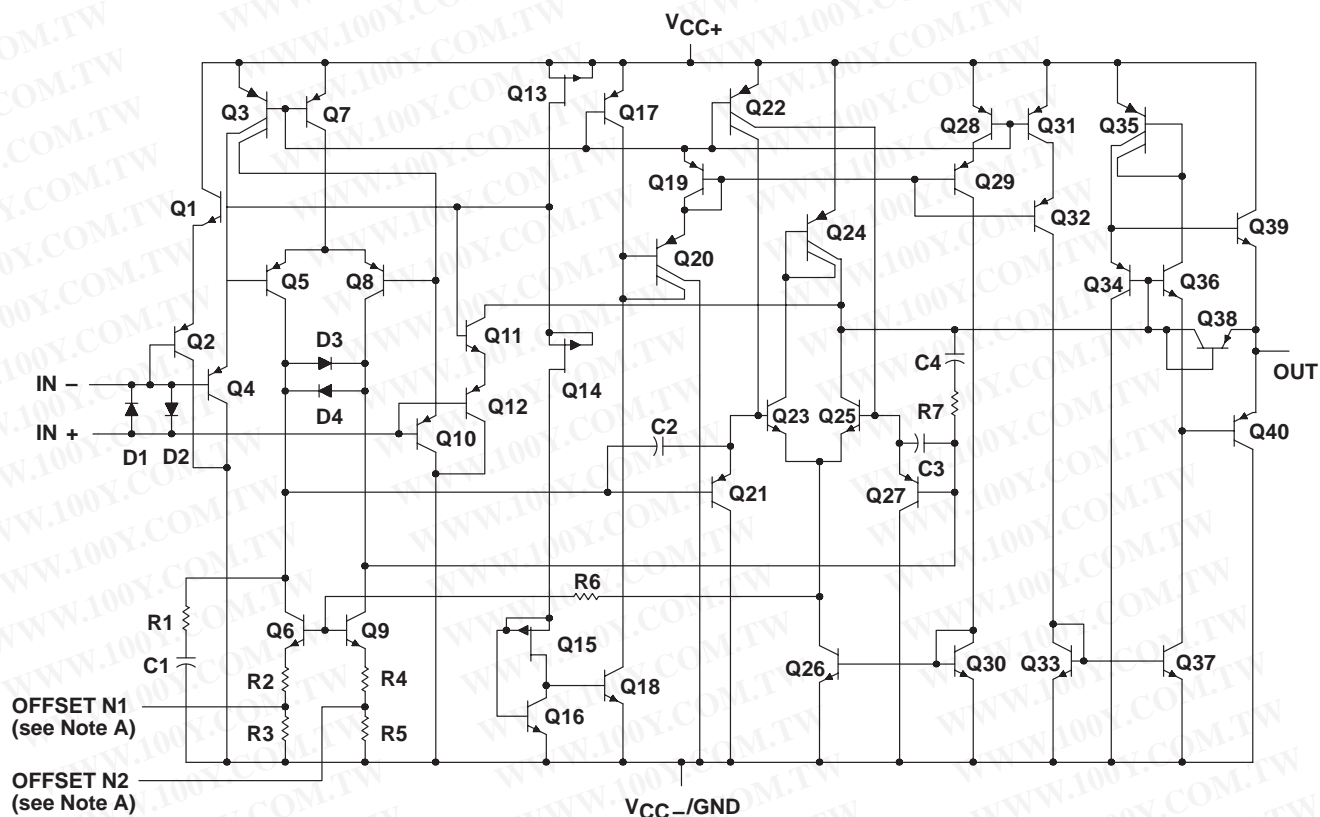

| ACTUAL DEVICE COMPONENT COUNT |         |         |         |
|-------------------------------|---------|---------|---------|
| COMPONENT                     | TLE2021 | TLE2022 | TLE2024 |
| Transistors                   | 40      | 80      | 160     |
| Resistors                     | 7       | 14      | 28      |
| Diodes                        | 4       | 8       | 16      |
| Capacitors                    | 4       | 8       | 16      |

勝特力材料 886-3-5753170  
 勝特力电子(上海) 86-21-34970699  
 勝特力电子(深圳) 86-755-83298787  
[Http://www.100y.com.tw](http://www.100y.com.tw)



# TLE202x, TLE202xA, TLE202xB, TLE202xY EXCALIBUR HIGH-SPEED LOW-POWER PRECISION OPERATIONAL AMPLIFIERS

SLOS191 – FEBRUARY 1997

## absolute maximum ratings over operating free-air temperature range (unless otherwise noted)†

|   |                              |
|---|------------------------------|
| Supply voltage, $V_{CC+}$ (see Note 1)  | 20 V                         |
| Supply voltage, $V_{CC-}$ (see Note 1)  | -20 V                        |
| Differential input voltage, $V_{ID}$ (see Note 2)                                     | $\pm 0.6$ V                  |
| Input voltage range, $V_I$ (any input, see Note 1)                                    | $\pm V_{CC}$                 |
| Input current, $I_I$ (each input)   | $\pm 1$ mA                   |
| Output current, $I_O$ (each output): TLE2021  | $\pm 20$ mA                  |
| TLE2022   | $\pm 30$ mA                  |
| TLE2024   | $\pm 40$ mA                  |
| Total current into $V_{CC+}$  | 80 mA                        |
| Total current out of $V_{CC-}$  | 80 mA                        |
| Duration of short-circuit current at (or below) 25°C (see Note 3)                     | unlimited                    |
| Continuous total power dissipation  | See Dissipation Rating Table |
| Operating free-air temperature range, $T_A$ : C suffix                                | 0°C to 70°C                  |
| I suffix  | -40°C to 85°C                |
| M suffix  | -55°C to 125°C               |
| Storage temperature range, $T_{stg}$  | -65°C to 150°C               |
| Case temperature for 60 seconds, $T_C$ : FK package                                   | 260°C                        |
| Lead temperature 1,6 mm (1/16 inch) from case for 10 seconds: D, DP, P, or PW package | 260°C                        |
| Lead temperature 1,6 mm (1/16 inch) from case for 60 seconds: JG package              | 300°C                        |

勝特力材料 886-3-5753170  
 勝特力电子(上海) 86-21-34970699  
 勝特力电子(深圳) 86-755-83298787  
[Http://www.100y.com.tw](http://www.100y.com.tw)

† Stresses beyond those listed under “absolute maximum ratings” may cause permanent damage to the device. These are stress ratings only, and functional operation of the device at these or any other conditions beyond those indicated under “recommended operating conditions” is not implied. Exposure to absolute-maximum-rated conditions for extended periods may affect device reliability.

- NOTES:
- All voltage values, except differential voltages, are with respect to the midpoint between  $V_{CC+}$  and  $V_{CC-}$ .
  - Differential voltages are at  $IN+$  with respect to  $IN-$ . Excessive current flows if a differential input voltage in excess of approximately  $\pm 600$  mV is applied between the inputs unless some limiting resistance is used.
  - The output may be shorted to either supply. Temperature and/or supply voltages must be limited to ensure that the maximum dissipation rating is not exceeded.

DISSIPATION RATING TABLE

| PACKAGE | $T_A \leq 25^\circ\text{C}$<br>POWER RATING | DERATING FACTOR<br>ABOVE $T_A = 25^\circ\text{C}$ | $T_A = 70^\circ\text{C}$<br>POWER RATING | $T_A = 85^\circ\text{C}$<br>POWER RATING | $T_A = 125^\circ\text{C}$<br>POWER RATING |
|---------|---|---|--|--|---|
| D-8     | 725 mW                                      | 5.8 mW/°C   | 464 mW                                   | 377 mW                                   | 145 mW                                    |
| DB-8    | 525 mW                                      | 4.2 mW/°C   | 336 mW                                   | —  | —   |
| DW-16   | 1025 mW                                     | 8.2 mW/°C   | 656 mW                                   | 533 mW                                   | 205 mW                                    |
| FK      | 1375 mW                                     | 11.0 mW/°C  | 880 mW                                   | 715 mW                                   | 275 mW                                    |
| J-14    | 1375 mW                                     | 11.0 mW/°C  | 880 mW                                   | 715 mW                                   | 275 mW                                    |
| JG-8    | 1050 mW                                     | 8.4 mW/°C   | 672 mW                                   | 546 mW                                   | 210 mW                                    |
| N-14    | 1150 mW                                     | 9.2 mW/°C   | 736 mW                                   | 598 mW                                   | 230 mW                                    |
| P-8     | 1000 mW                                     | 8.0 mW/°C   | 640 mW                                   | 520 mW                                   | 200 mW                                    |
| PW-8    | 525 mW                                      | 4.2 mW/°C   | 336 mW                                   | —  | —   |

## recommended operating conditions

|                                       | C SUFFIX               |          | I SUFFIX |          | M SUFFIX |          | UNIT |
|---------------------------------------|------------------------|----------|----------|----------|----------|----------|------|
|                                       | MIN                    | MAX      | MIN      | MAX      | MIN      | MAX      |      |
| Supply voltage, $V_{CC}$              | $\pm 2$                | $\pm 20$ | $\pm 2$  | $\pm 20$ | $\pm 2$  | $\pm 20$ | V    |
| Common-mode input voltage, $V_{IC}$   | $V_{CC} = \pm 5$ V     |          | 0        | 3.5      | 0        | 3.2      | V    |
|                                       | $V_{CC\pm} = \pm 15$ V |          | -15      | 13.5     | -15      | 13.2     |      |
| Operating free-air temperature, $T_A$ | 0                      | 70       | -40      | 85       | -55      | 125      | °C   |



TLE2021 electrical characteristics at specified free-air temperature,  $V_{CC} = 5\text{ V}$  (unless otherwise noted)

| PARAMETER  | TEST CONDITIONS  | $T_A$ †    | TLE2021C |           |      | TLE2021AC |           |      | TLE2021BC |           |                              | UNIT          |
|--|--|------------|----------|-----------|------|-----------|-----------|------|-----------|-----------|------------------------------|---------------|
|  |  |            | MIN      | TYP       | MAX  | MIN       | TYP       | MAX  | MIN       | TYP       | MAX                          |               |
| $V_{IO}$ Input offset voltage  |  | 25°C       |          | 120       | 600  |           | 100       | 300  |           | 80        | 200                          | $\mu\text{V}$ |
|  |  | Full range |          |           | 850  |           |           | 600  |           |           | 300                          |               |
| $\alpha_{VIO}$ Temperature coefficient of input offset voltage             |  | Full range |          | 2         |      |           | 2         |      |           | 2         | $\mu\text{V}/^\circ\text{C}$ |               |
| Input offset voltage long-term drift (see Note 4)                          | $V_{IC} = 0, R_S = 50\ \Omega$                               | 25°C       |          | 0.005     |      |           | 0.005     |      |           | 0.005     | $\mu\text{V}/\text{mo}$      |               |
| $I_{IO}$ Input offset current  |  | 25°C       |          | 0.2       | 6    |           | 0.2       | 6    |           | 0.2       | 6                            | nA            |
| $I_{IB}$ Input bias current  |  | 25°C       |          | 25        | 70   |           | 25        | 70   |           | 25        | 70                           | nA            |
|  |  | Full range |          |           | 90   |           |           | 90   |           |           | 90                           |               |
| $V_{ICR}$ Common-mode input voltage range                                  | $R_S = 50\ \Omega$   | 25°C       | 0 to 3.5 | -0.3 to 4 |      | 0 to 3.5  | -0.3 to 4 |      | 0 to 3.5  | -0.3 to 4 | V                            |               |
|  |  | Full range | 0 to 3.5 |           |      | 0 to 3.5  |           |      | 0 to 3.5  |           |                              |               |
| $V_{OH}$ High-level output voltage   | $R_L = 10\ \text{k}\Omega$                                   | 25°C       | 4        | 4.3       |      | 4         | 4.3       |      | 4         | 4.3       | V                            |               |
|  |  | Full range | 3.9      |           |      | 3.9       |           |      | 3.9       |           |                              |               |
| $V_{OL}$ Low-level output voltage  |  | 25°C       |          | 0.7       | 0.8  |           | 0.7       | 0.8  |           | 0.7       | 0.8                          | V             |
|  |  | Full range |          |           | 0.85 |           |           | 0.85 |           |           | 0.85                         |               |
| $A_{VD}$ Large-signal differential voltage amplification                   | $V_O = 1.4\text{ V to }4\text{ V}, R_L = 10\ \text{k}\Omega$ | 25°C       | 0.3      | 1.5       |      | 0.3       | 1.5       |      | 0.3       | 1.5       | $\text{V}/\mu\text{V}$       |               |
|  |  | Full range | 0.3      |           |      | 0.3       |           |      | 0.3       |           |                              |               |
| CMRR Common-mode rejection ratio   | $V_{IC} = V_{ICR\text{min}}, R_S = 50\ \Omega$               | 25°C       | 85       | 110       |      | 85        | 110       |      | 85        | 110       | dB                           |               |
|  |  | Full range | 80       |           |      | 80        |           |      | 80        |           |                              |               |
| $k_{SVR}$ Supply-voltage rejection ratio ( $\Delta V_{CC}/\Delta V_{IO}$ ) | $V_{CC} = 5\text{ V to }30\text{ V}$                         | 25°C       | 105      | 120       |      | 105       | 120       |      | 105       | 120       | dB                           |               |
|  |  | Full range | 100      |           |      | 100       |           |      | 100       |           |                              |               |
| $I_{CC}$ Supply current  | $V_O = 2.5\text{ V},$<br>No load                             | 25°C       |          | 170       | 230  |           | 170       | 230  |           | 170       | 230                          | $\mu\text{A}$ |
|  |  | Full range |          |           | 230  |           |           | 230  |           |           | 230                          |               |
| $\Delta I_{CC}$ Supply-current change over operating temperature range     |  | Full range |          | 5         |      |           | 5         |      |           | 5         | $\mu\text{A}$                |               |

† Full range is 0°C to 70°C.

NOTE 4: Typical values are based on the input offset voltage shift observed through 168 hours of operating life test at  $T_A = 150^\circ\text{C}$  extrapolated to  $T_A = 25^\circ\text{C}$  using the Arrhenius equation and assuming an activation energy of 0.96 eV.

勝特力材料 886-3-5753170  
 勝特力电子(上海) 86-21-34970699  
 勝特力电子(深圳) 86-755-83298787  
[Http://www.100y.com.tw](http://www.100y.com.tw)

**TLE2021 electrical characteristics at specified free-air temperature,  $V_{CC} = \pm 15\text{ V}$  (unless otherwise noted)**

| PARAMETER  | TEST CONDITIONS                                      | $T_A$ †    | TLE2021C    |             |     | TLE2021AC   |             |     | TLE2021BC   |               |                              | UNIT |
|--|--|------------|-------------|-------------|-----|-------------|-------------|-----|-------------|---------------|------------------------------|------|
|  |  |            | MIN         | TYP         | MAX | MIN         | TYP         | MAX | MIN         | TYP           | MAX                          |      |
| $V_{IO}$ Input offset voltage  |  | 25°C       | 120         | 500         |     | 80          | 200         |     | 40          | 100           | $\mu\text{V}$                |      |
|  |  | Full range |             | 750         |     | 500         |             | 200 |             |               |                              |      |
| $\alpha_{VIO}$ Temperature coefficient of input offset voltage             |  | Full range | 2           |             |     | 2           |             |     | 2           |               | $\mu\text{V}/^\circ\text{C}$ |      |
| Input offset voltage long-term drift (see Note 4)                          | $V_{IC} = 0, R_S = 50\ \Omega$                       | 25°C       | 0.006       |             |     | 0.006       |             |     | 0.006       |               | $\mu\text{V}/\text{mo}$      |      |
| $I_{IO}$ Input offset current  |  | 25°C       | 0.2         | 6           |     | 0.2         | 6           |     | 0.2         | 6             | nA                           |      |
|  | Full range   |            | 10          |             | 10  |             | 10          |     |             |               |                              |      |
| $I_{IB}$ Input bias current  |  | 25°C       | 25          | 70          |     | 25          | 70          |     | 25          | 70            | nA                           |      |
|  |  | Full range |             | 90          |     | 90          |             | 90  |             |               |                              |      |
| $V_{ICR}$ Common-mode input voltage range                                  | $R_S = 50\ \Omega$                                   | 25°C       | -15 to 13.5 | -15.3 to 14 |     | -15 to 13.5 | -15.3 to 14 |     | -15 to 13.5 | -15.3 to 14   | V                            |      |
|  |  | Full range | -15 to 13.5 |             |     | 15 to 13.5  |             |     | 15 to 13.5  |               |                              |      |
| $V_{OM+}$ Maximum positive peak output voltage swing                       | $R_L = 10\ \text{k}\Omega$                           | 25°C       | 14          | 14.3        |     | 14          | 14.3        |     | 14          | 14.3          | V                            |      |
|  |  | Full range | 13.9        |             |     | 13.9        |             |     | 13.9        |               |                              |      |
| $V_{OM-}$ Maximum negative peak output voltage swing                       |  | 25°C       | -13.7       | -14.1       |     | -13.7       | -14.1       |     | -13.7       | -14.1         | V                            |      |
|  |  | Full range | -13.7       |             |     | -13.7       |             |     | -13.7       |               |                              |      |
| $A_{VD}$ Large-signal differential voltage amplification                   | $V_O = \pm 10\ \text{V}, R_L = 10\ \text{k}\Omega$   | 25°C       | 1           | 6.5         |     | 1           | 6.5         |     | 1           | 6.5           | $\text{V}/\mu\text{V}$       |      |
|  |  | Full range | 1           |             |     | 1           |             |     | 1           |               |                              |      |
| CMRR Common-mode rejection ratio   | $V_{IC} = V_{ICR}\ \text{min}, R_S = 50\ \Omega$     | 25°C       | 100         | 115         |     | 100         | 115         |     | 100         | 115           | dB                           |      |
|  |  | Full range | 96          |             |     | 96          |             |     | 96          |               |                              |      |
| $k_{SVR}$ Supply-voltage rejection ratio ( $\Delta V_{CC}/\Delta V_{IO}$ ) | $V_{CC} \pm \pm 2.5\ \text{V}$ to $\pm 15\ \text{V}$ | 25°C       | 105         | 120         |     | 105         | 120         |     | 105         | 120           | dB                           |      |
|  |  | Full range | 100         |             |     | 100         |             |     | 100         |               |                              |      |
| $I_{CC}$ Supply current  | $V_O = 0, \text{ No load}$                           | 25°C       | 200         | 300         |     | 200         | 300         |     | 200         | 300           | $\mu\text{A}$                |      |
|  |  | Full range |             | 300         |     | 300         |             | 300 |             |               |                              |      |
| $\Delta I_{CC}$ Supply-current change over operating temperature range     |  | Full range | 6           |             |     | 6           |             |     | 6           | $\mu\text{A}$ |                              |      |

† Full range is 0°C to 70°C.

NOTE 4: Typical values are based on the input offset voltage shift observed through 168 hours of operating life test at  $T_A = 150^\circ\text{C}$  extrapolated to  $T_A = 25^\circ\text{C}$  using the Arrhenius equation and assuming an activation energy of 0.96 eV.

勝特力材料 886-3-5753170  
 勝特力电子(上海) 86-21-34970699  
 勝特力电子(深圳) 86-755-83298787  
[Http://www.100y.com.tw](http://www.100y.com.tw)

TLE2022 electrical characteristics at specified free-air temperature,  $V_{CC} = 5\text{ V}$  (unless otherwise noted)

| PARAMETER  | TEST CONDITIONS  | $T_A$ †    | TLE2022C |           |     | TLE2022AC |           |     | TLE2022BC |           |     | UNIT                         |
|--|--|------------|----------|-----------|-----|-----------|-----------|-----|-----------|-----------|-----|------------------------------|
|  |  |            | MIN      | TYP       | MAX | MIN       | TYP       | MAX | MIN       | TYP       | MAX |                              |
| $V_{IO}$ Input offset voltage  |  | 25°C       | 600      |           |     | 400       |           |     | 250       |           |     | $\mu\text{V}$                |
|  |  | Full range | 800      |           |     | 550       |           |     | 400       |           |     |                              |
| $\alpha_{VIO}$ Temperature coefficient of input offset voltage                 | $V_{IC} = 0, R_S = 50\ \Omega$                               | Full range | 2        |           |     | 2         |           |     | 2         |           |     | $\mu\text{V}/^\circ\text{C}$ |
| Input offset voltage long-term drift (see Note 4)                              |  | 25°C       | 0.005    |           |     | 0.005     |           |     | 0.005     |           |     | $\mu\text{V}/\text{mo}$      |
| $I_{IO}$ Input offset current  |  | 25°C       | 0.5 6    |           |     | 0.4 6     |           |     | 0.3 6     |           |     | nA                           |
|  | Full range   | 10         |          |           | 10  |           |           | 10  |           |           |     |                              |
| $I_{IB}$ Input bias current  |  | 25°C       | 35 70    |           |     | 33 70     |           |     | 30 70     |           |     | nA                           |
|  |  | Full range | 90       |           |     | 90        |           |     | 90        |           |     |                              |
| $V_{ICR}$ Common-mode input voltage range                                      | $R_S = 50\ \Omega$   | 25°C       | 0 to 3.5 | -0.3 to 4 |     | 0 to 3.5  | -0.3 to 4 |     | 0 to 3.5  | -0.3 to 4 |     | V                            |
|  |  | Full range | 0 to 3.5 |           |     | 0 to 3.5  |           |     | 0 to 3.5  |           |     |                              |
| $V_{OH}$ High-level output voltage   | $R_L = 10\ \text{k}\Omega$                                   | 25°C       | 4 4.3    |           |     | 4 4.3     |           |     | 4 4.3     |           |     | V                            |
|  |  | Full range | 3.9      |           |     | 3.9       |           |     | 3.9       |           |     |                              |
| $V_{OL}$ Low-level output voltage  |  | 25°C       | 0.7 0.8  |           |     | 0.7 0.8   |           |     | 0.7 0.8   |           |     | V                            |
|  |  | Full range | 0.85     |           |     | 0.85      |           |     | 0.85      |           |     |                              |
| $A_{VD}$ Large-signal differential voltage amplification                       | $V_O = 1.4\text{ V to }4\text{ V}, R_L = 10\ \text{k}\Omega$ | 25°C       | 0.3 1.5  |           |     | 0.4 1.5   |           |     | 0.5 1.5   |           |     | $\text{V}/\mu\text{V}$       |
|  |  | Full range | 0.3      |           |     | 0.4       |           |     | 0.5       |           |     |                              |
| CMRR Common-mode rejection ratio   | $V_{IC} = V_{ICR\text{min}}, R_S = 50\ \Omega$               | 25°C       | 85 100   |           |     | 87 102    |           |     | 90 105    |           |     | dB                           |
|  |  | Full range | 80       |           |     | 82        |           |     | 85        |           |     |                              |
| $k_{SVR}$ Supply-voltage rejection ratio ( $\Delta V_{CC} \pm \Delta V_{IO}$ ) | $V_{CC} = 5\text{ V to }30\text{ V}$                         | 25°C       | 100 115  |           |     | 103 118   |           |     | 105 120   |           |     | dB                           |
|  |  | Full range | 95       |           |     | 98        |           |     | 100       |           |     |                              |
| $I_{CC}$ Supply current  | $V_O = 2.5\text{ V},$ No load                                | 25°C       | 450 600  |           |     | 450 600   |           |     | 450 600   |           |     | $\mu\text{A}$                |
|  |  | Full range | 600      |           |     | 600       |           |     | 600       |           |     |                              |
| $\Delta I_{CC}$ Supply current change over operating temperature range         |  | Full range | 7        |           |     | 7         |           |     | 7         |           |     | $\mu\text{A}$                |

† Full range is 0°C to 70°C.

NOTE 4: Typical values are based on the input offset voltage shift observed through 168 hours of operating life test at  $T_A = 150^\circ\text{C}$  extrapolated to  $T_A = 25^\circ\text{C}$  using the Arrhenius equation and assuming an activation energy of 0.96 eV.

勝特力材料 886-3-5753170  
 勝特力电子(上海) 86-21-34970699  
 勝特力电子(深圳) 86-755-83298787  
[Http://www.100y.com.tw](http://www.100y.com.tw)

**TLE2022 electrical characteristics at specified free-air temperature,  $V_{CC} = \pm 15\text{ V}$  (unless otherwise noted)**

| PARAMETER   | TEST CONDITIONS                                      | $T_A$ †    | TLE2022C    |             |     | TLE2022AC   |             |     | TLE2022BC   |             |                        | UNIT                         |
|---|--|------------|-------------|-------------|-----|-------------|-------------|-----|-------------|-------------|------------------------|------------------------------|
|   |  |            | MIN         | TYP         | MAX | MIN         | TYP         | MAX | MIN         | TYP         | MAX                    |                              |
| $V_{IO}$ Input offset voltage   |  | 25°C       | 150         | 500         |     | 120         | 300         |     | 70          | 150         | $\mu\text{V}$          |                              |
|   |  | Full range |             | 700         |     |             | 450         |     |             | 300         |                        |                              |
| $\alpha_{VIO}$ Temperature coefficient of input offset voltage                |  | Full range | 2           |             |     | 2           |             |     | 2           |             |                        | $\mu\text{V}/^\circ\text{C}$ |
| Input offset voltage long-term drift (see Note 4)                             | $V_{IC} = 0, R_S = 50\ \Omega$                       | 25°C       | 0.006       |             |     | 0.006       |             |     | 0.006       |             |                        | $\mu\text{V}/\text{mo}$      |
| $I_{IO}$ Input offset current   |  | 25°C       | 0.5         | 6           |     | 0.4         | 6           |     | 0.3         | 6           | nA                     |                              |
|   |  | Full range |             | 10          |     |             | 10          |     |             | 10          |                        |                              |
| $I_{IB}$ Input bias current   |  | 25°C       | 35          | 70          |     | 33          | 70          |     | 30          | 70          | nA                     |                              |
|   |  | Full range |             | 90          |     |             | 90          |     |             | 90          |                        |                              |
| $V_{ICR}$ Common-mode input voltage range                                     | $R_S = 50\ \Omega$                                   | 25°C       | -15 to 13.5 | -15.3 to 14 |     | -15 to 13.5 | -15.3 to 14 |     | -15 to 13.5 | -15.3 to 14 | V                      |                              |
|   |  | Full range | -15 to 13.5 |             |     | -15 to 13.5 |             |     | -15 to 13.5 |             |                        |                              |
| $V_{OM+}$ Maximum positive peak output voltage swing                          | $R_L = 10\ \text{k}\Omega$                           | 25°C       | 14          | 14.3        |     | 14          | 14.3        |     | 14          | 14.3        | V                      |                              |
|   |  | Full range | 13.9        |             |     | 13.9        |             |     | 13.9        |             |                        |                              |
| $V_{OM-}$ Maximum negative peak output voltage swing                          | $R_L = 10\ \text{k}\Omega$                           | 25°C       | -13.7       | -14.1       |     | -13.7       | -14.1       |     | -13.7       | -14.1       | V                      |                              |
|   |  | Full range | -13.7       |             |     | -13.7       |             |     | -13.7       |             |                        |                              |
| $A_{VD}$ Large-signal differential voltage amplification                      | $V_O = \pm 10\ \text{V}, R_L = 10\ \text{k}\Omega$   | 25°C       | 0.8         | 4           |     | 1           | 7           |     | 1.5         | 10          | $\text{V}/\mu\text{V}$ |                              |
|   |  | Full range | 0.8         |             |     | 1           |             |     | 1.5         |             |                        |                              |
| CMRR Common-mode rejection ratio  | $V_{IC} = V_{ICRmin}, R_S = 50\ \Omega$              | 25°C       | 95          | 106         |     | 97          | 109         |     | 100         | 112         | dB                     |                              |
|   |  | Full range | 91          |             |     | 93          |             |     | 96          |             |                        |                              |
| $k_{SVR}$ Supply-voltage rejection ratio ( $\Delta V_{CC\pm}/\Delta V_{IO}$ ) | $V_{CC\pm} = \pm 2.5\ \text{V to } \pm 15\ \text{V}$ | 25°C       | 100         | 115         |     | 103         | 118         |     | 105         | 120         | dB                     |                              |
|   |  | Full range | 95          |             |     | 98          |             |     | 100         |             |                        |                              |
| $I_{CC}$ Supply current   | $V_O = 0, \text{ No load}$                           | 25°C       | 550         | 700         |     | 550         | 700         |     | 550         | 700         | $\mu\text{A}$          |                              |
|   |  | Full range |             | 700         |     |             | 700         |     |             | 700         |                        |                              |
| $\Delta I_{CC}$ Supply current change over operating temperature range        |  | Full range | 9           |             |     | 9           |             |     | 9           |             |                        | $\mu\text{A}$                |

† Full range is 0°C to 70°C.

NOTE 4: Typical values are based on the input offset voltage shift observed through 168 hours of operating life test at  $T_A = 150^\circ\text{C}$  extrapolated to  $T_A = 25^\circ\text{C}$  using the Arrhenius equation and assuming an activation energy of 0.96 eV.

勝特力材料 886-3-5753170  
 勝特力电子(上海) 86-21-34970699  
 勝特力电子(深圳) 86-755-83298787  
[Http://www.100y.com.tw](http://www.100y.com.tw)

TLE2024 electrical characteristics at specified free-air temperature,  $V_{CC} = 5\text{ V}$  (unless otherwise noted)

| PARAMETER  | TEST CONDITIONS   | $T_A$ †    | TLE2024C |           |          | TLE2024AC |          |             | TLE2024BC              |     |     | UNIT                         |
|--|---|------------|----------|-----------|----------|-----------|----------|-------------|------------------------|-----|-----|------------------------------|
|  |   |            | MIN      | TYP       | MAX      | MIN       | TYP      | MAX         | MIN                    | TYP | MAX |                              |
| $V_{IO}$ Input offset voltage  | $V_{IC} = 0, R_S = 50\ \Omega$                                  | 25°C       | 1100     |           |          | 850       |          |             | 600                    |     |     | $\mu\text{V}$                |
|  |   | Full range | 1300     |           |          | 1050      |          |             | 800                    |     |     |                              |
| $\alpha_{VIO}$ Temperature coefficient of input offset voltage             |   | Full range | 2        |           |          | 2         |          |             | 2                      |     |     | $\mu\text{V}/^\circ\text{C}$ |
| Input offset voltage long-term drift (see Note 4)                          |   | 25°C       | 0.005    |           |          | 0.005     |          |             | 0.005                  |     |     | $\mu\text{V}/\text{mo}$      |
| $I_{IO}$ Input offset current  |   | 25°C       | 0.6      | 6         | 0.5      | 6         | 0.4      | 6           | $\text{nA}$            |     |     |                              |
|  |   | Full range | 10       |           |          | 10        |          |             |                        |     |     | 10                           |
| $I_{IB}$ Input bias current  | 25°C  | 45         | 70       | 40        | 70       | 35        | 70       | $\text{nA}$ |                        |     |     |                              |
|  | Full range  | 90         |          |           | 90       |           |          |             |                        |     | 90  |                              |
| $V_{ICR}$ Common-mode input voltage range                                  | $R_S = 50\ \Omega$  | 25°C       | 0 to 3.5 | -0.3 to 4 | 0 to 3.5 | -0.3 to 4 | 0 to 3.5 | -0.3 to 4   | $\text{V}$             |     |     |                              |
|  |   | Full range | 0 to 3.5 |           | 0 to 3.5 |           | 0 to 3.5 |             |                        |     |     |                              |
| $V_{OH}$ High-level output voltage   | $R_L = 10\ \text{k}\Omega$                                      | 25°C       | 3.9      | 4.2       | 3.9      | 4.2       | 4        | 4.3         | $\text{V}$             |     |     |                              |
|  |   | Full range | 3.7      |           |          | 3.7       |          |             |                        |     |     | 3.8                          |
| $V_{OL}$ Low-level output voltage  |   | 25°C       | 0.7      | 0.8       | 0.7      | 0.8       | 0.7      | 0.8         | $\text{V}$             |     |     |                              |
|  |   | Full range | 0.95     |           |          | 0.95      |          |             |                        |     |     | 0.95                         |
| $A_{VD}$ Large-signal differential voltage amplification                   | $V_O = 1.4\ \text{V to } 4\ \text{V}, R_L = 10\ \text{k}\Omega$ | 25°C       | 0.2      | 1.5       | 0.3      | 1.5       | 0.4      | 1.5         | $\text{V}/\mu\text{V}$ |     |     |                              |
|  |   | Full range | 0.1      |           |          | 0.1       |          |             |                        |     |     | 0.1                          |
| CMRR Common-mode rejection ratio   | $V_{IC} = V_{ICRmin}, R_S = 50\ \Omega$                         | 25°C       | 80       | 90        | 82       | 92        | 85       | 95          | $\text{dB}$            |     |     |                              |
|  |   | Full range | 80       |           |          | 82        |          |             |                        |     |     | 85                           |
| $k_{SVR}$ Supply-voltage rejection ratio ( $\Delta V_{CC}/\Delta V_{IO}$ ) | $V_{CC} = 5\ \text{V to } 30\ \text{V}$                         | 25°C       | 98       | 112       | 100      | 115       | 103      | 117         | $\text{dB}$            |     |     |                              |
|  |   | Full range | 93       |           |          | 95        |          |             |                        |     |     | 98                           |
| $I_{CC}$ Supply current  | $V_O = 2.5\ \text{V}, \text{ No load}$                          | 25°C       | 800      | 1200      | 800      | 1200      | 800      | 1200        | $\mu\text{A}$          |     |     |                              |
|  |   | Full range | 1200     |           |          | 1200      |          |             |                        |     |     | 1200                         |
| $\Delta I_{CC}$ Supply current change over operating temperature range     |   | Full range | 15       |           |          | 15        |          |             | 15                     |     |     | $\mu\text{A}$                |

† Full range is 0°C to 70°C.

NOTE 4: Typical values are based on the input offset voltage shift observed through 168 hours of operating life test at  $T_A = 150^\circ\text{C}$  extrapolated to  $T_A = 25^\circ\text{C}$  using the Arrhenius equation and assuming an activation energy of 0.96 eV.

勝特力材料 886-3-5753170  
 勝特力电子(上海) 86-21-34970699  
 勝特力电子(深圳) 86-755-83298787  
[Http://www.100y.com.tw](http://www.100y.com.tw)

**TLE2024 electrical characteristics at specified free-air temperature,  $V_{CC} = \pm 15\text{ V}$  (unless otherwise noted)**

| PARAMETER   | TEST CONDITIONS                                      | $T_A^\dagger$ | TLE2024C    |             |             | TLE2024AC   |             |             | TLE2024BC              |     |     | UNIT                         |
|---|--|---------------|-------------|-------------|-------------|-------------|-------------|-------------|------------------------|-----|-----|------------------------------|
|   |  |               | MIN         | TYP         | MAX         | MIN         | TYP         | MAX         | MIN                    | TYP | MAX |                              |
| $V_{IO}$ Input offset voltage   | $V_{IC} = 0, R_S = 50\ \Omega$                       | 25°C          | 1000        |             |             | 750         |             |             | 500                    |     |     | $\mu\text{V}$                |
|   |  | Full range    | 1200        |             |             | 950         |             |             | 700                    |     |     |                              |
| $\alpha_{VIO}$ Temperature coefficient of input offset voltage                |  | Full range    | 2           |             |             | 2           |             |             | 2                      |     |     | $\mu\text{V}/^\circ\text{C}$ |
| Input offset voltage long-term drift (see Note 4)                             |  | 25°C          | 0.006       |             |             | 0.006       |             |             | 0.006                  |     |     | $\mu\text{V}/\text{mo}$      |
| $I_{IO}$ Input offset current   |  | 25°C          | 0.6         | 6           | 0.5         | 6           | 0.4         | 6           | $\text{nA}$            |     |     |                              |
|   |  | Full range    | 10          |             |             | 10          |             |             |                        |     |     |                              |
| $I_{IB}$ Input bias current   | 25°C   | 50            | 70          | 45          | 70          | 40          | 70          | $\text{nA}$ |                        |     |     |                              |
|   | Full range   | 90            |             |             | 90          |             |             |             |                        |     |     |                              |
| $V_{ICR}$ Common-mode input voltage range                                     | $R_S = 50\ \Omega$                                   | 25°C          | -15 to 13.5 | -15.3 to 14 | -15 to 13.5 | -15.3 to 14 | -15 to 13.5 | -15.3 to 14 | $\text{V}$             |     |     |                              |
|   |  | Full range    | -15 to 13.5 | -15 to 13.5 | -15 to 13.5 | -15 to 13.5 | -15 to 13.5 |             |                        |     |     |                              |
| $V_{OM+}$ Maximum positive peak output voltage swing                          | $R_L = 10\ \text{k}\Omega$                           | 25°C          | 13.8        | 14.1        | 13.9        | 14.2        | 14          | 14.3        | $\text{V}$             |     |     |                              |
|   |  | Full range    | 13.7        |             | 13.8        |             | 13.9        |             |                        |     |     |                              |
| $V_{OM-}$ Maximum negative peak output voltage swing                          |  | 25°C          | -13.7       | -14.1       | -13.7       | -14.1       | -13.7       | -14.1       | $\text{V}$             |     |     |                              |
|   |  | Full range    | -13.6       |             | -13.6       |             | -13.6       |             |                        |     |     |                              |
| $A_{VD}$ Large-signal differential voltage amplification                      | $V_O = \pm 10\ \text{V}, R_L = 10\ \text{k}\Omega$   | 25°C          | 0.4         | 2           | 0.8         | 4           | 1           | 7           | $\text{V}/\mu\text{V}$ |     |     |                              |
|   |  | Full range    | 0.4         |             | 0.8         |             | 1           |             |                        |     |     |                              |
| CMRR Common-mode rejection ratio  | $V_{IC} = V_{ICR\text{min}}, R_S = 50\ \Omega$       | 25°C          | 92          | 102         | 94          | 105         | 97          | 108         | dB                     |     |     |                              |
|   |  | Full range    | 88          |             | 90          |             | 93          |             |                        |     |     |                              |
| $k_{SVR}$ Supply-voltage rejection ratio ( $\Delta V_{CC\pm}/\Delta V_{IO}$ ) | $V_{CC\pm} = \pm 2.5\ \text{V to } \pm 15\ \text{V}$ | 25°C          | 98          | 112         | 100         | 115         | 103         | 117         | dB                     |     |     |                              |
|   |  | Full range    | 93          |             | 95          |             | 98          |             |                        |     |     |                              |
| $I_{CC}$ Supply current   | $V_O = 0, \text{ No load}$                           | 25°C          | 1050        | 1400        | 1050        | 1400        | 1050        | 1400        | $\mu\text{A}$          |     |     |                              |
|   |  | Full range    | 1400        |             |             | 1400        |             |             |                        |     |     |                              |
| $\Delta I_{CC}$ Supply current change over operating temperature range        |  | Full range    | 20          |             |             | 20          |             |             | $\mu\text{A}$          |     |     |                              |

$^\dagger$  Full range is 0°C to 70°C.

NOTE 4: Typical values are based on the input offset voltage shift observed through 168 hours of operating life test at  $T_A = 150^\circ\text{C}$  extrapolated to  $T_A = 25^\circ\text{C}$  using the Arrhenius equation and assuming an activation energy of 0.96 eV.

勝特力材料 886-3-5753170  
 勝特力电子(上海) 86-21-34970699  
 勝特力电子(深圳) 86-755-83298787  
[Http://www.100y.com.tw](http://www.100y.com.tw)

TLE2021 electrical characteristics at specified free-air temperature,  $V_{CC} = 5\text{ V}$  (unless otherwise noted)

| PARAMETER  | TEST CONDITIONS  | $T_A$ †    | TLE2021I   |           |     | TLE2021AI |           |     | TLE2021BI |           |                              | UNIT          |
|--|--|------------|------------|-----------|-----|-----------|-----------|-----|-----------|-----------|------------------------------|---------------|
|  |  |            | MIN        | TYP       | MAX | MIN       | TYP       | MAX | MIN       | TYP       | MAX                          |               |
| $V_{IO}$ Input offset voltage  |  | 25°C       |            | 120       | 600 |           | 100       | 300 |           | 80        | 200                          | $\mu\text{V}$ |
|  |  | Full range |            |           | 950 |           |           | 600 |           |           | 300                          |               |
| $\alpha_{VIO}$ Temperature coefficient of input offset voltage             |  | Full range |            | 2         |     |           | 2         |     |           | 2         | $\mu\text{V}/^\circ\text{C}$ |               |
| Input offset voltage long-term drift (see Note 4)                          | $V_{IC} = 0, R_S = 50\ \Omega$                               | 25°C       |            | 0.005     |     |           | 0.005     |     |           | 0.005     | $\mu\text{V}/\text{mo}$      |               |
| $I_{IO}$ Input offset current  |  | 25°C       |            | 0.2       | 6   |           | 0.2       | 6   |           | 0.2       | 6                            | nA            |
| $I_{IB}$ Input bias current  |  | 25°C       |            | 25        | 70  |           | 25        | 70  |           | 25        | 70                           | nA            |
|  |  | Full range |            |           | 90  |           |           | 90  |           |           | 90                           |               |
| $V_{ICR}$ Common-mode input voltage range                                  | $R_S = 50\ \Omega$   | 25°C       | 0 to 3.5   | -0.3 to 4 |     | 0 to 3.5  | -0.3 to 4 |     | 0 to 3.5  | -0.3 to 4 | V                            |               |
|  |  | Full range | -15 to 3.2 |           |     | 15 to 3.2 |           |     | 0 to 3.2  |           |                              |               |
| $V_{OH}$ High-level output voltage   | $R_L = 10\ \text{k}\Omega$                                   | 25°C       | 4          | 4.3       |     | 4         | 4.3       |     | 4         | 4.3       | V                            |               |
|  |  | Full range | 3.9        |           |     | 3.9       |           |     | 3.9       |           |                              |               |
| $V_{OL}$ Low-level output voltage  |  | 25°C       |            | 0.7       | 0.8 |           | 0.7       | 0.8 |           | 0.7       | 0.8                          | V             |
|  |  | Full range |            |           | 0.9 |           |           | 0.9 |           |           | 0.9                          |               |
| $A_{VD}$ Large-signal differential voltage amplification                   | $V_O = 1.4\text{ V to }4\text{ V}, R_L = 10\ \text{k}\Omega$ | 25°C       | 0.3        | 1.5       |     | 0.3       | 1.5       |     | 0.3       | 1.5       | $\text{V}/\mu\text{V}$       |               |
|  |  | Full range | 0.25       |           |     | 0.25      |           |     | 0.25      |           |                              |               |
| CMRR Common-mode rejection ratio   | $V_{IC} = V_{ICR}\ \text{min}, R_S = 50\ \Omega$             | 25°C       | 85         | 110       |     | 85        | 110       |     | 85        | 110       | dB                           |               |
|  |  | Full range | 80         |           |     | 80        |           |     | 80        |           |                              |               |
| $k_{SVR}$ Supply-voltage rejection ratio ( $\Delta V_{CC}/\Delta V_{IO}$ ) | $V_{CC} = 5\text{ V to }30\text{ V}$                         | 25°C       | 105        | 120       |     | 105       | 120       |     | 105       | 120       | dB                           |               |
|  |  | Full range | 100        |           |     | 100       |           |     | 100       |           |                              |               |
| $I_{CC}$ Supply current  | $V_O = 2.5\text{ V},$<br>No load                             | 25°C       |            | 170       | 230 |           | 170       | 230 |           | 170       | 230                          | $\mu\text{A}$ |
|  |  | Full range |            |           | 230 |           |           | 230 |           |           | 230                          |               |
| $\Delta I_{CC}$ Supply-current change over operating temperature range     |  | Full range |            | 6         |     |           | 6         |     |           | 6         | $\mu\text{A}$                |               |

† Full range is  $-40^\circ\text{C}$  to  $85^\circ\text{C}$ .

NOTE 4: Typical values are based on the input offset voltage shift observed through 168 hours of operating life test at  $T_A = 150^\circ\text{C}$  extrapolated to  $T_A = 25^\circ\text{C}$  using the Arrhenius equation and assuming an activation energy of 0.96 eV.

勝特力材料 886-3-5753170  
 勝特力电子(上海) 86-21-34970699  
 勝特力电子(深圳) 86-755-83298787  
[Http://www.100y.com.tw](http://www.100y.com.tw)

**TLE2021 electrical characteristics at specified free-air temperature,  $V_{CC} = \pm 15\text{ V}$  (unless otherwise noted)**

| PARAMETER  | TEST CONDITIONS                                      | $T_A$ †    | TLE2021I    |             |     | TLE2021AI   |             |     | TLE2021BI   |             |     | UNIT                         |
|--|--|------------|-------------|-------------|-----|-------------|-------------|-----|-------------|-------------|-----|------------------------------|
|  |  |            | MIN         | TYP         | MAX | MIN         | TYP         | MAX | MIN         | TYP         | MAX |                              |
| $V_{IO}$ Input offset voltage  |  | 25°C       | 120 500     |             |     | 80 200      |             |     | 40 100      |             |     | $\mu\text{V}$                |
|  |  | Full range | 850         |             |     | 500         |             |     | 200         |             |     |                              |
| $\alpha_{VIO}$ Temperature coefficient of input offset voltage             |  | Full range | 2           |             |     | 2           |             |     | 2           |             |     | $\mu\text{V}/^\circ\text{C}$ |
| Input offset voltage long-term drift (see Note 4)                          | $V_{IC} = 0, R_S = 50\ \Omega$                       | 25°C       | 0.006       |             |     | 0.006       |             |     | 0.006       |             |     | $\mu\text{V}/\text{mo}$      |
| $I_{IO}$ Input offset current  |  | 25°C       | 0.2 6       |             |     | 0.2 6       |             |     | 0.2 6       |             |     | nA                           |
|  | Full range   | 10         |             |             | 10  |             |             | 10  |             |             |     |                              |
| $I_{IB}$ Input bias current  |  | 25°C       | 25 70       |             |     | 25 70       |             |     | 25 70       |             |     | nA                           |
|  |  | Full range | 90          |             |     | 90          |             |     | 90          |             |     |                              |
| $V_{ICR}$ Common-mode input voltage range                                  | $R_S = 50\ \Omega$                                   | 25°C       | -15 to 13.5 | -15.3 to 14 |     | -15 to 13.5 | -15.3 to 14 |     | -15 to 13.5 | -15.3 to 14 |     | V                            |
|  |  | Full range | -15 to 3.2  |             |     | 15 to 3.2   |             |     | 15 to 3.2   |             |     |                              |
| $V_{OM+}$ Maximum positive peak output voltage swing                       | $R_L = 10\ \text{k}\Omega$                           | 25°C       | 14 14.3     |             |     | 14 14.3     |             |     | 14 14.3     |             |     | V                            |
|  |  | Full range | 13.9        |             |     | 13.9        |             |     | 13.9        |             |     |                              |
| $V_{OM-}$ Maximum negative peak output voltage swing                       |  | 25°C       | -13.7 -14.1 |             |     | -13.7 -14.1 |             |     | -13.7 -14.1 |             |     | V                            |
|  |  | Full range | -13.6       |             |     | -13.6       |             |     | -13.6       |             |     |                              |
| $A_{VD}$ Large-signal differential voltage amplification                   | $V_O = 10\text{ V}, R_L = 10\ \text{k}\Omega$        | 25°C       | 1 6.5       |             |     | 1 6.5       |             |     | 1 6.5       |             |     | $\text{V}/\mu\text{V}$       |
|  |  | Full range | 0.75        |             |     | 0.75        |             |     | 0.75        |             |     |                              |
| CMRR Common-mode rejection ratio   | $V_{IC} = V_{ICR}\ \text{min}, R_S = 50\ \Omega$     | 25°C       | 100 115     |             |     | 100 115     |             |     | 100 115     |             |     | dB                           |
|  |  | Full range | 96          |             |     | 96          |             |     | 96          |             |     |                              |
| $k_{SVR}$ Supply-voltage rejection ratio ( $\Delta V_{CC}/\Delta V_{IO}$ ) | $V_{CC} \pm = \pm 2.5\text{ V}$ to $\pm 15\text{ V}$ | 25°C       | 105 120     |             |     | 105 120     |             |     | 105 120     |             |     | dB                           |
|  |  | Full range | 100         |             |     | 100         |             |     | 100         |             |     |                              |
| $I_{CC}$ Supply current  | $V_O = 0\text{ V}, \text{ No load}$                  | 25°C       | 200 300     |             |     | 200 300     |             |     | 200 300     |             |     | $\mu\text{A}$                |
|  |  | Full range | 300         |             |     | 300         |             |     | 300         |             |     |                              |
| $\Delta I_{CC}$ Supply-current change over operating temperature range     |  | Full range | 7           |             |     | 7           |             |     | 7           |             |     | $\mu\text{A}$                |

† Full range is  $-40^\circ\text{C}$  to  $85^\circ\text{C}$ .  
 NOTE 4: Typical values are based on the input offset voltage shift observed through 168 hours of operating life test at  $T_A = 150^\circ\text{C}$  extrapolated to  $T_A = 25^\circ\text{C}$  using the Arrhenius equation and assuming an activation energy of 0.96 eV.

**勝特力材料 886-3-5753170**  
**勝特力电子(上海) 86-21-34970699**  
**勝特力电子(深圳) 86-755-83298787**  
[Http://www.100y.com.tw](http://www.100y.com.tw)

TLE2022 electrical characteristics at specified free-air temperature,  $V_{CC} = 5\text{ V}$  (unless otherwise noted)

| PARAMETER   | TEST CONDITIONS  | $T_A$ †    | TLE2022I |           |     | TLE2022AI |           |     | TLE2022BI |           |                              | UNIT          |
|---|--|------------|----------|-----------|-----|-----------|-----------|-----|-----------|-----------|------------------------------|---------------|
|   |  |            | MIN      | TYP       | MAX | MIN       | TYP       | MAX | MIN       | TYP       | MAX                          |               |
| $V_{IO}$ Input offset voltage   |  | 25°C       |          |           | 600 |           |           | 400 |           |           | 250                          | $\mu\text{V}$ |
|   |  | Full range |          |           | 800 |           |           | 550 |           |           | 400                          |               |
| $\alpha_{VIO}$ Temperature coefficient of input offset voltage                | $V_{IC} = 0, R_S = 50\ \Omega$                               | Full range |          | 2         |     |           | 2         |     |           | 2         | $\mu\text{V}/^\circ\text{C}$ |               |
| Input offset voltage long-term drift (see Note 4)                             |  | 25°C       |          | 0.005     |     |           | 0.005     |     |           | 0.005     | $\mu\text{V}/\text{mo}$      |               |
| $I_{IO}$ Input offset current   |  | 25°C       |          | 0.5       | 6   |           | 0.4       | 6   |           | 0.3       | 6                            | nA            |
|   | Full range   |            |          | 10        |     |           | 10        |     |           | 10        |                              |               |
| $I_{IB}$ Input bias current   |  | 25°C       |          | 35        | 70  |           | 33        | 70  |           | 30        | 70                           | nA            |
|   |  | Full range |          |           | 90  |           |           | 90  |           |           | 90                           |               |
| $V_{ICR}$ Common-mode input voltage range                                     | $R_S = 50\ \Omega$   | 25°C       | 0 to 3.5 | -0.3 to 4 |     | 0 to 3.5  | -0.3 to 4 |     | 0 to 3.5  | -0.3 to 4 | V                            |               |
|   |  | Full range | 0 to 3.2 |           |     | 0 to 3.2  |           |     | 0 to 3.2  |           |                              |               |
| $V_{OH}$ High-level output voltage  | $R_L = 10\ \text{k}\Omega$                                   | 25°C       | 4        | 4.3       |     | 4         | 4.3       |     | 4         | 4.3       | V                            |               |
|   |  | Full range | 3.9      |           |     | 3.9       |           |     | 3.9       |           |                              |               |
| $V_{OL}$ Low-level output voltage   |  | 25°C       |          | 0.7       | 0.8 |           | 0.7       | 0.8 |           | 0.7       | 0.8                          | V             |
|   |  | Full range |          |           | 0.9 |           |           | 0.9 |           |           | 0.9                          |               |
| $A_{VD}$ Large-signal differential voltage amplification                      | $V_O = 1.4\text{ V to }4\text{ V}, R_L = 10\ \text{k}\Omega$ | 25°C       | 0.3      | 1.5       |     | 0.4       | 1.5       |     | 0.5       | 1.5       | $\text{V}/\mu\text{V}$       |               |
|   |  | Full range | 0.2      |           |     | 0.2       |           |     | 0.2       |           |                              |               |
| CMRR Common-mode rejection ratio  | $V_{IC} = V_{ICR\text{min}}, R_S = 50\ \Omega$               | 25°C       | 85       | 100       |     | 87        | 102       |     | 90        | 105       | dB                           |               |
|   |  | Full range | 80       |           |     | 82        |           |     | 85        |           |                              |               |
| $k_{SVR}$ Supply-voltage rejection ratio ( $\Delta V_{CC\pm}/\Delta V_{IO}$ ) | $V_{CC} = 5\text{ V to }30\text{ V}$                         | 25°C       | 100      | 115       |     | 103       | 118       |     | 105       | 120       | dB                           |               |
|   |  | Full range | 95       |           |     | 98        |           |     | 100       |           |                              |               |
| $I_{CC}$ Supply current   | $V_O = 2.5\text{ V},$ No load                                | 25°C       |          | 450       | 600 |           | 450       | 600 |           | 450       | 600                          | $\mu\text{A}$ |
|   |  | Full range |          |           | 600 |           |           | 600 |           |           | 600                          |               |
| $\Delta I_{CC}$ Supply current change over operating temperature range        |  | Full range |          | 15        |     |           | 15        |     |           | 15        | $\mu\text{A}$                |               |

† Full range is  $-40^\circ\text{C}$  to  $85^\circ\text{C}$ .

NOTE 4: Typical values are based on the input offset voltage shift observed through 168 hours of operating life test at  $T_A = 150^\circ\text{C}$  extrapolated to  $T_A = 25^\circ\text{C}$  using the Arrhenius equation and assuming an activation energy of 0.96 eV.

勝特力材料 886-3-5753170  
 勝特力电子(上海) 86-21-34970699  
 勝特力电子(深圳) 86-755-83298787  
[Http://www.100y.com.tw](http://www.100y.com.tw)

**TLE2022 electrical characteristics at specified free-air temperature,  $V_{CC} = \pm 15\text{ V}$  (unless otherwise noted)**

| PARAMETER   | TEST CONDITIONS                                    | $T_A$ †    | TLE2022I    |             |     | TLE2022AI   |             |     | TLE2022BI   |             |                        | UNIT                         |
|---|--|------------|-------------|-------------|-----|-------------|-------------|-----|-------------|-------------|------------------------|------------------------------|
|   |  |            | MIN         | TYP         | MAX | MIN         | TYP         | MAX | MIN         | TYP         | MAX                    |                              |
| $V_{IO}$ Input offset voltage   |  | 25°C       | 150         | 500         |     | 120         | 300         |     | 70          | 150         | $\mu\text{V}$          |                              |
|   |  | Full range |             | 700         |     |             | 450         |     |             | 300         |                        |                              |
| $\alpha_{VIO}$ Temperature coefficient of input offset voltage                  |  | Full range | 2           |             |     | 2           |             |     | 2           |             |                        | $\mu\text{V}/^\circ\text{C}$ |
| Input offset voltage long-term drift (see Note 4)                               | $V_{IC} = 0, R_S = 50\ \Omega$                     | 25°C       | 0.006       |             |     | 0.006       |             |     | 0.006       |             |                        | $\mu\text{V}/\text{mo}$      |
| $I_{IO}$ Input offset current   |  | 25°C       | 0.5         | 6           |     | 0.4         | 6           |     | 0.3         | 6           | nA                     |                              |
|   |  | Full range | 10          |             |     | 10          |             |     | 10          |             |                        |                              |
| $I_{IB}$ Input bias current   |  | 25°C       | 35          | 70          |     | 33          | 70          |     | 30          | 70          | nA                     |                              |
|   |  | Full range | 90          |             |     | 90          |             |     | 90          |             |                        |                              |
| $V_{ICR}$ Common-mode input voltage range                                       | $R_S = 50\ \Omega$                                 | 25°C       | -15 to 13.5 | -15.3 to 14 |     | -15 to 13.5 | -15.3 to 14 |     | -15 to 13.5 | -15.3 to 14 | V                      |                              |
|   |  | Full range | -15 to 13.2 |             |     | -15 to 13.2 |             |     | -15 to 13.2 |             |                        |                              |
| $V_{OM+}$ Maximum positive peak output voltage swing                            | $R_L = 10\ \text{k}\Omega$                         | 25°C       | 14          | 14.3        |     | 14          | 14.3        |     | 14          | 14.3        | V                      |                              |
|   |  | Full range | 13.9        |             |     | 13.9        |             |     | 13.9        |             |                        |                              |
| $V_{OM-}$ Maximum negative peak output voltage swing                            |  | 25°C       | -13.7       | -14.1       |     | -13.7       | -14.1       |     | -13.7       | -14.1       | V                      |                              |
|   |  | Full range | -13.6       |             |     | -13.6       |             |     | -13.6       |             |                        |                              |
| $A_{VD}$ Large-signal differential voltage amplification                        | $V_O = \pm 10\ \text{V}, R_L = 10\ \text{k}\Omega$ | 25°C       | 0.8         | 4           |     | 1           | 7           |     | 1.5         | 10          | $\text{V}/\mu\text{V}$ |                              |
|   |  | Full range | 0.8         |             |     | 1           |             |     | 1.5         |             |                        |                              |
| CMRR Common-mode rejection ratio  | $V_{IC} = V_{ICRmin}, R_S = 50\ \Omega$            | 25°C       | 95          | 106         |     | 97          | 109         |     | 100         | 112         | dB                     |                              |
|   |  | Full range | 91          |             |     | 93          |             |     | 96          |             |                        |                              |
| $k_{SVR}$ Supply-voltage rejection ratio ( $\Delta V_{CC\pm} / \Delta V_{IO}$ ) | $V_{CC} = \pm 2.5\ \text{V to } \pm 15\ \text{V}$  | 25°C       | 100         | 115         |     | 103         | 118         |     | 105         | 120         | dB                     |                              |
|   |  | Full range | 95          |             |     | 98          |             |     | 100         |             |                        |                              |
| $I_{CC}$ Supply current   | $V_O = 0, \text{ No load}$                         | 25°C       | 550         | 700         |     | 550         | 700         |     | 550         | 700         | $\mu\text{A}$          |                              |
|   |  | Full range | 700         |             |     | 700         |             |     | 700         |             |                        |                              |
| $\Delta I_{CC}$ Supply current change over operating temperature range          |  | Full range | 30          |             |     | 30          |             |     | 30          |             |                        | $\mu\text{A}$                |

† Full range is  $-40^\circ\text{C}$  to  $85^\circ\text{C}$ .

NOTE 4: Typical values are based on the input offset voltage shift observed through 168 hours of operating life test at  $T_A = 150^\circ\text{C}$  extrapolated to  $T_A = 25^\circ\text{C}$  using the Arrhenius equation and assuming an activation energy of 0.96 eV.

勝特力材料 886-3-5753170  
 勝特力电子(上海) 86-21-34970699  
 勝特力电子(深圳) 86-755-83298787  
[Http://www.100y.com.tw](http://www.100y.com.tw)

TLE2024 electrical characteristics at specified free-air temperature,  $V_{CC} = 5\text{ V}$  (unless otherwise noted)

| PARAMETER   | TEST CONDITIONS   | $T_A$ †    | TLE2024I |           |          | TLE2024AI |          |             | TLE2024BI              |     |     | UNIT                         |
|---|---|------------|----------|-----------|----------|-----------|----------|-------------|------------------------|-----|-----|------------------------------|
|   |   |            | MIN      | TYP       | MAX      | MIN       | TYP      | MAX         | MIN                    | TYP | MAX |                              |
| $V_{IO}$ Input offset voltage   | $V_{IC} = 0, R_S = 50\ \Omega$                                  | 25°C       | 1100     |           |          | 850       |          |             | 600                    |     |     | $\mu\text{V}$                |
|   |   | Full range | 1300     |           |          | 1050      |          |             | 800                    |     |     |                              |
| $\alpha_{VIO}$ Temperature coefficient of input offset voltage                |   | Full range | 2        |           |          | 2         |          |             | 2                      |     |     | $\mu\text{V}/^\circ\text{C}$ |
| Input offset voltage long-term drift (see Note 4)                             |   | 25°C       | 0.005    |           |          | 0.005     |          |             | 0.005                  |     |     | $\mu\text{V}/\text{mo}$      |
| $I_{IO}$ Input offset current   |   | 25°C       | 0.6      | 6         | 0.5      | 6         | 0.4      | 6           | $\text{nA}$            |     |     |                              |
|   |   | Full range | 10       |           |          | 10        |          |             |                        |     |     |                              |
| $I_{IB}$ Input bias current   | 25°C  | 45         | 70       | 40        | 70       | 35        | 70       | $\text{nA}$ |                        |     |     |                              |
|   | Full range  | 90         |          |           | 90       |           |          |             |                        |     |     |                              |
| $V_{ICR}$ Common-mode input voltage range                                     | $R_S = 50\ \Omega$  | 25°C       | 0 to 3.5 | -0.3 to 4 | 0 to 3.5 | -0.3 to 4 | 0 to 3.5 | -0.3 to 4   | $\text{V}$             |     |     |                              |
|   |   | Full range | 0 to 3.2 |           | 0 to 3.2 |           | 0 to 3.2 |             |                        |     |     |                              |
| $V_{OM+}$ Maximum positive peak output voltage swing                          | $R_L = 10\ \text{k}\Omega$                                      | 25°C       | 3.9      | 4.2       | 3.9      | 4.2       | 4        | 4.3         | $\text{V}$             |     |     |                              |
|   |   | Full range | 3.7      |           | 3.7      |           | 3.8      |             |                        |     |     |                              |
| $V_{OM-}$ Maximum negative peak output voltage swing                          |   | 25°C       | 0.7      | 0.8       | 0.7      | 0.8       | 0.7      | 0.8         | $\text{V}$             |     |     |                              |
|   |   | Full range | 0.95     |           | 0.95     |           | 0.95     |             |                        |     |     |                              |
| $A_{VD}$ Large-signal differential voltage amplification                      | $V_O = 1.4\ \text{V to } 4\ \text{V}, R_L = 10\ \text{k}\Omega$ | 25°C       | 0.2      | 1.5       | 0.3      | 1.5       | 0.4      | 1.5         | $\text{V}/\mu\text{V}$ |     |     |                              |
|   |   | Full range | 0.1      |           | 0.1      |           | 0.1      |             |                        |     |     |                              |
| CMRR Common-mode rejection ratio  | $V_{IC} = V_{ICRmin}, R_S = 50\ \Omega$                         | 25°C       | 80       | 90        | 82       | 92        | 85       | 95          | $\text{dB}$            |     |     |                              |
|   |   | Full range | 80       |           | 82       |           | 85       |             |                        |     |     |                              |
| $k_{SVR}$ Supply-voltage rejection ratio ( $\Delta V_{CC\pm}/\Delta V_{IO}$ ) | $V_{CC\pm} = \pm 2.5\ \text{V to } \pm 15\ \text{V}$            | 25°C       | 98       | 112       | 100      | 115       | 103      | 117         | $\text{dB}$            |     |     |                              |
|   |   | Full range | 93       |           | 95       |           | 98       |             |                        |     |     |                              |
| $I_{CC}$ Supply current   | $V_O = 0, \text{ No load}$                                      | 25°C       | 800      | 1200      | 800      | 1200      | 800      | 1200        | $\mu\text{A}$          |     |     |                              |
|   |   | Full range | 1200     |           | 1200     |           | 1200     |             |                        |     |     |                              |
| $\Delta I_{CC}$ Supply current change over operating temperature range        |   | Full range | 30       |           | 30       |           | 30       |             | $\mu\text{A}$          |     |     |                              |

† Full range is  $-40^\circ\text{C}$  to  $85^\circ\text{C}$ .

NOTE 4: Typical values are based on the input offset voltage shift observed through 168 hours of operating life test at  $T_A = 150^\circ\text{C}$  extrapolated to  $T_A = 25^\circ\text{C}$  using the Arrhenius equation and assuming an activation energy of 0.96 eV.

勝特力材料 886-3-5753170  
 勝特力电子(上海) 86-21-34970699  
 勝特力电子(深圳) 86-755-83298787  
[Http://www.100y.com.tw](http://www.100y.com.tw)

**TLE2024 electrical characteristics at specified free-air temperature,  $V_{CC} = \pm 15\text{ V}$  (unless otherwise noted)**

| PARAMETER   | TEST CONDITIONS                                      | $T_A^\dagger$ | TLE2024I    |             |             | TLE2024AI   |             |             | TLE2024BI |     |                        | UNIT                         |
|---|--|---------------|-------------|-------------|-------------|-------------|-------------|-------------|-----------|-----|------------------------|------------------------------|
|   |  |               | MIN         | TYP         | MAX         | MIN         | TYP         | MAX         | MIN       | TYP | MAX                    |                              |
| $V_{IO}$ Input offset voltage   |  | 25°C          | 1000        |             |             | 750         |             |             | 500       |     |                        | $\mu\text{V}$                |
|   |  | Full range    | 1200        |             |             | 950         |             |             | 700       |     |                        |                              |
| $\alpha_{VIO}$ Temperature coefficient of input offset voltage                |  | Full range    | 2           |             |             | 2           |             |             | 2         |     |                        | $\mu\text{V}/^\circ\text{C}$ |
| Input offset voltage long-term drift (see Note 4)                             | $V_{IC} = 0, R_S = 50\ \Omega$                       | 25°C          | 0.006       |             |             | 0.006       |             |             | 0.006     |     |                        | $\mu\text{V}/\text{mo}$      |
| $I_{IO}$ Input offset current   |  | 25°C          | 0.6         | 6           | 0.5         | 6           | 0.4         | 6           |           |     |                        | nA                           |
|   | Full range   | 10            |             |             | 10          |             |             | 10          |           |     |                        |                              |
| $I_{IB}$ Input bias current   |  | 25°C          | 50          | 70          | 45          | 70          | 40          | 70          |           |     | nA                     |                              |
|   |  | Full range    | 90          |             |             | 90          |             |             | 90        |     |                        |                              |
| $V_{ICR}$ Common-mode input voltage range                                     | $R_S = 50\ \Omega$                                   | 25°C          | -15 to 13.5 | -15.3 to 14 | -15 to 13.5 | -15.3 to 14 | -15 to 13.5 | -15.3 to 14 |           |     | V                      |                              |
|   |  | Full range    | -15 to 13.2 |             | -15 to 13.2 |             | -15 to 13.2 |             |           |     |                        |                              |
| $V_{OM+}$ Maximum positive peak output voltage swing                          | $R_L = 10\ \text{k}\Omega$                           | 25°C          | 13.8        | 14.1        | 13.9        | 14.2        | 14          | 14.3        |           |     | V                      |                              |
|   |  | Full range    | 13.7        |             |             | 13.7        |             |             | 13.8      |     |                        |                              |
| $V_{OM-}$ Maximum negative peak output voltage swing                          |  | 25°C          | -13.7       | -14.1       | -13.7       | -14.1       | -13.7       | -14.1       |           |     | V                      |                              |
|   |  | Full range    | -13.6       |             |             | -13.6       |             |             | -13.6     |     |                        |                              |
| $A_{VD}$ Large-signal differential voltage amplification                      | $V_O = \pm 10\ \text{V}, R_L = 10\ \text{k}\Omega$   | 25°C          | 0.4         | 2           | 0.8         | 4           | 1           | 7           |           |     | $\text{V}/\mu\text{V}$ |                              |
|   |  | Full range    | 0.4         |             |             | 0.8         |             |             | 1         |     |                        |                              |
| CMRR Common-mode rejection ratio  | $V_{IC} = V_{ICR\text{min}}, R_S = 50\ \Omega$       | 25°C          | 92          | 102         | 94          | 105         | 97          | 108         |           |     | dB                     |                              |
|   |  | Full range    | 88          |             |             | 90          |             |             | 93        |     |                        |                              |
| $k_{SVR}$ Supply-voltage rejection ratio ( $\Delta V_{CC\pm}/\Delta V_{IO}$ ) | $V_{CC\pm} = \pm 2.5\ \text{V to } \pm 15\ \text{V}$ | 25°C          | 98          | 112         | 100         | 115         | 103         | 117         |           |     | dB                     |                              |
|   |  | Full range    | 93          |             |             | 95          |             |             | 98        |     |                        |                              |
| $I_{CC}$ Supply current   | $V_O = 0, \text{ No load}$                           | 25°C          | 1050        | 1400        | 1050        | 1400        | 1050        | 1400        |           |     | $\mu\text{A}$          |                              |
|   |  | Full range    | 1400        |             |             | 1400        |             |             | 1400      |     |                        |                              |
| $\Delta I_{CC}$ Supply current change over operating temperature range        |  | Full range    | 50          |             |             | 50          |             |             | 50        |     |                        | $\mu\text{A}$                |

$^\dagger$  Full range is  $-40^\circ\text{C}$  to  $85^\circ\text{C}$ .

NOTE 4: Typical values are based on the input offset voltage shift observed through 168 hours of operating life test at  $T_A = 150^\circ\text{C}$  extrapolated to  $T_A = 25^\circ\text{C}$  using the Arrhenius equation and assuming an activation energy of 0.96 eV.

勝特力材料 886-3-5753170  
 勝特力电子(上海) 86-21-34970699  
 勝特力电子(深圳) 86-755-83298787  
[Http://www.100y.com.tw](http://www.100y.com.tw)

**TLE2021 electrical characteristics at specified free-air temperature,  $V_{CC} = 5\text{ V}$  (unless otherwise noted)**

| PARAMETER  | TEST CONDITIONS  | $T_A$ †    | TLE2021M |           |      | TLE2021AM |           |      | TLE2021BM |           |                  | UNIT                         |
|--|--|------------|----------|-----------|------|-----------|-----------|------|-----------|-----------|------------------|------------------------------|
|  |  |            | MIN      | TYP       | MAX  | MIN       | TYP       | MAX  | MIN       | TYP       | MAX              |                              |
| $V_{IO}$ Input offset voltage  |  | 25°C       |          | 120       | 600  |           | 100       | 300  |           | 80        | 200              | $\mu\text{V}$                |
|  |  | Full range |          |           | 1100 |           |           | 600  |           |           | 300              |                              |
| $\alpha_{VIO}$ Temperature coefficient of input offset voltage                   | $V_{IC} = 0,$<br>$R_S = 50\ \Omega$                                  | Full range |          | 2         |      |           | 2         |      |           | 2         |                  | $\mu\text{V}/^\circ\text{C}$ |
| Input offset voltage long-term drift (see Note 4)                                |  | 25°C       |          | 0.005     |      |           | 0.005     |      |           | 0.005     |                  | $\mu\text{V}/\text{mo}$      |
| $I_{IO}$ Input offset current  |  | 25°C       |          | 0.2       | 6    |           | 0.2       | 6    |           | 0.2       | 6                | nA                           |
|  |  | Full range |          |           | 10   |           |           | 10   |           |           | 10               |                              |
| $I_{IB}$ Input bias current  | 25°C   |            | 25       | 70        |      | 25        | 70        |      | 25        | 70        | nA               |                              |
|  | Full range   |            |          | 90        |      |           | 90        |      |           | 90        |                  |                              |
| $V_{ICR}$ Common-mode input voltage range  | $R_S = 50\ \Omega$   | 25°C       | 0 to 3.5 | -0.3 to 4 |      | 0 to 3.5  | -0.3 to 4 |      | 0 to 3.5  | -0.3 to 4 | V                |                              |
|  |  | Full range | 0 to 3.2 |           |      | 0 to 3.2  |           |      | 0 to 3.2  |           |                  |                              |
| $V_{OH}$ High-level output voltage   | $R_L = 10\ \text{k}\Omega$   | 25°C       | 4        | 4.3       |      | 4         | 4.3       |      | 4         | 4.3       | V                |                              |
|  |  | Full range | 3.8      |           |      | 3.8       |           |      | 3.8       |           |                  |                              |
| $V_{OL}$ Low-level output voltage  |  | 25°C       |          | 0.7       | 0.8  |           | 0.7       | 0.8  |           | 0.7       | 0.8              | V                            |
|  |  | Full range |          |           | 0.95 |           |           | 0.95 |           |           | 0.95             |                              |
| $A_{VD}$ Large-signal differential voltage amplification                         | $V_O = 1.4\ \text{V to } 4\ \text{V},$<br>$R_L = 10\ \text{k}\Omega$ | 25°C       | 0.3      | 1.5       |      | 0.3       | 1.5       |      | 0.3       | 1.5       | V/ $\mu\text{V}$ |                              |
|  |  | Full range | 0.1      |           |      | 0.1       |           |      | 0.1       |           |                  |                              |
| CMRR Common-mode rejection ratio   | $V_{IC} = V_{ICRmin},$<br>$R_S = 50\ \Omega$                         | 25°C       | 85       | 110       |      | 85        | 110       |      | 85        | 110       | dB               |                              |
|  |  | Full range | 80       |           |      | 80        |           |      | 80        |           |                  |                              |
| $k_{SVR}$ Supply-voltage rejection ratio ( $\Delta V_{CC} \pm / \Delta V_{IO}$ ) | $V_{CC} = 5\ \text{V to } 30\ \text{V}$                              | 25°C       | 105      | 120       |      | 105       | 120       |      | 105       | 120       | dB               |                              |
|  |  | Full range | 100      |           |      | 100       |           |      | 100       |           |                  |                              |
| $I_{CC}$ Supply current  | $V_O = 2.5\ \text{V},$<br>No load                                    | 25°C       |          | 170       | 230  |           | 170       | 230  |           | 170       | 230              | $\mu\text{A}$                |
|  |  | Full range |          |           | 230  |           |           | 230  |           |           | 230              |                              |
| $\Delta I_{CC}$ Supply current change over operating temperature range           |  | Full range |          | 9         |      |           | 9         |      |           | 9         |                  | $\mu\text{A}$                |

† Full range is  $-55^\circ\text{C}$  to  $125^\circ\text{C}$ .

NOTE 4: Typical values are based on the input offset voltage shift observed through 168 hours of operating life test at  $T_A = 150^\circ\text{C}$  extrapolated to  $T_A = 25^\circ\text{C}$  using the Arrhenius equation and assuming an activation energy of 0.96 eV.

勝特力材料 886-3-5753170  
 勝特力电子(上海) 86-21-34970699  
 勝特力电子(深圳) 86-755-83298787  
[Http://www.100y.com.tw](http://www.100y.com.tw)

**TLE2021 electrical characteristics at specified free-air temperature,  $V_{CC} = \pm 15$  V (unless otherwise noted)**

| PARAMETER   | TEST CONDITIONS                                      | $T_A$ †    | TLE2021M    |             |      | TLE2021AM   |             |     | TLE2021BM   |             |            | UNIT    |
|---|--|------------|-------------|-------------|------|-------------|-------------|-----|-------------|-------------|------------|---------|
|   |  |            | MIN         | TYP         | MAX  | MIN         | TYP         | MAX | MIN         | TYP         | MAX        |         |
| $V_{IO}$ Input offset voltage   |  | 25°C       |             | 120         | 500  |             | 80          | 200 |             | 40          | 100        | $\mu$ V |
|   |  | Full range |             |             | 1000 |             |             | 500 |             |             | 200        |         |
| $\alpha_{VIO}$ Temperature coefficient of input offset voltage                  |  | Full range |             | 2           |      |             | 2           |     |             | 2           | $\mu$ V/°C |         |
| Input offset voltage long-term drift (see Note 4)                               | $V_{IC} = 0, R_S = 50 \Omega$                        | 25°C       |             | 0.006       |      |             | 0.006       |     |             | 0.006       | $\mu$ V/mo |         |
| $I_{IO}$ Input offset current   |  | 25°C       |             | 0.2         | 6    |             | 0.2         | 6   |             | 0.2         | 6          | nA      |
|   |  | Full range |             |             | 10   |             |             | 10  |             |             | 10         |         |
| $I_{IB}$ Input bias current   |  | 25°C       |             | 25          | 70   |             | 25          | 70  |             | 25          | 70         | nA      |
|   |  | Full range |             |             | 90   |             |             | 90  |             |             | 90         |         |
| $V_{ICR}$ Common-mode input voltage range                                       | $R_S = 50 \Omega$                                    | 25°C       | -15 to 13.5 | -15.3 to 14 |      | -15 to 13.5 | -15.3 to 14 |     | -15 to 13.5 | -15.3 to 14 | V          |         |
|   |  | Full range | -15 to 13.2 |             |      | -15 to 13.2 |             |     | 0 to 13.2   |             |            |         |
| $V_{OM+}$ Maximum positive peak output voltage swing                            | $R_L = 10 \text{ k}\Omega$                           | 25°C       | 14          | 14.3        |      | 14          | 14.3        |     | 14          | 14.3        | V          |         |
|   |  | Full range | 13.8        |             |      | 13.8        |             |     | 13.8        |             |            |         |
| $V_{OM-}$ Maximum negative peak output voltage swing                            |  | 25°C       | -13.7       | -14.1       |      | -13.7       | -14.1       |     | -13.7       | -14.1       | V          |         |
|   |  | Full range | -13.6       |             |      | -13.6       |             |     | -13.6       |             |            |         |
| $A_{VD}$ Large-signal differential voltage amplification                        | $V_O = \pm 10 \text{ V}, R_L = 10 \text{ k}\Omega$   | 25°C       | 1           | 6.5         |      | 1           | 6.5         |     | 1           | 6.5         | V/ $\mu$ V |         |
|   |  | Full range | 0.5         |             |      | 0.5         |             |     | 0.5         |             |            |         |
| CMRR Common-mode rejection ratio  | $V_{IC} = V_{ICRmin}, R_S = 50 \Omega$               | 25°C       | 100         | 115         |      | 100         | 115         |     | 100         | 115         | dB         |         |
|   |  | Full range | 96          |             |      | 96          |             |     | 96          |             |            |         |
| $k_{SVR}$ Supply-voltage rejection ratio ( $\Delta V_{CC\pm} / \Delta V_{IO}$ ) | $V_{CC\pm} = \pm 2.5 \text{ V to } \pm 15 \text{ V}$ | 25°C       | 105         | 120         |      | 105         | 120         |     | 105         | 120         | dB         |         |
|   |  | Full range | 100         |             |      | 100         |             |     | 100         |             |            |         |
| $I_{CC}$ Supply current   | $V_O = 0, \text{ No load}$                           | 25°C       |             | 200         | 300  |             | 200         | 300 |             | 200         | 300        | $\mu$ A |
|   |  | Full range |             |             | 300  |             |             | 300 |             |             | 300        |         |
| $\Delta I_{CC}$ Supply current change over operating temperature range          |  | Full range |             | 10          |      |             | 10          |     |             | 10          | $\mu$ A    |         |

† Full range is -55°C to 125°C.

NOTE 4: Typical values are based on the input offset voltage shift observed through 168 hours of operating life test at  $T_A = 150^\circ\text{C}$  extrapolated to  $T_A = 25^\circ\text{C}$  using the Arrhenius equation and assuming an activation energy of 0.96 eV.

TLE2022 electrical characteristics at specified free-air temperature,  $V_{CC} = 5\text{ V}$  (unless otherwise noted)

| PARAMETER   | TEST CONDITIONS  | $T_A$ †    | TLE2022M |           |          | TLE2022AM |          |           | TLE2022BM |           |     | UNIT                         |
|---|--|------------|----------|-----------|----------|-----------|----------|-----------|-----------|-----------|-----|------------------------------|
|   |  |            | MIN      | TYP       | MAX      | MIN       | TYP      | MAX       | MIN       | TYP       | MAX |                              |
| $V_{IO}$ Input offset voltage   |  | 25°C       | 600      |           |          | 400       |          |           | 250       |           |     | $\mu\text{V}$                |
|   |  | Full range | 800      |           |          | 550       |          |           | 400       |           |     |                              |
| $\alpha_{VIO}$ Temperature coefficient of input offset voltage                  | $V_{IC} = 0, R_S = 50\ \Omega$                               | Full range | 2        |           |          | 2         |          |           | 2         |           |     | $\mu\text{V}/^\circ\text{C}$ |
| Input offset voltage long-term drift (see Note 4)                               |  | 25°C       | 0.005    |           |          | 0.005     |          |           | 0.005     |           |     | $\mu\text{V}/\text{mo}$      |
| $I_{IO}$ Input offset current   |  | 25°C       | 0.5 6    |           |          | 0.4 6     |          |           | 0.3 6     |           |     | nA                           |
|   |  | Full range | 10       |           |          | 10        |          |           | 10        |           |     |                              |
| $I_{IB}$ Input bias current   | 25°C   | 35 70      |          |           | 33 70    |           |          | 30 70     |           |           | nA  |                              |
|   | Full range   | 90         |          |           | 90       |           |          | 90        |           |           |     |                              |
| $V_{ICR}$ Common-mode input voltage range                                       | $R_S = 50\ \Omega$   | 25°C       | 0 to 3.5 | -0.3 to 4 | 0 to 3.5 | -0.3 to 4 | 0 to 3.5 | -0.3 to 4 | 0 to 3.5  | -0.3 to 4 | V   |                              |
|   |  | Full range | 0 to 3.2 |           | 0 to 3.2 |           | 0 to 3.2 |           | 0 to 3.2  |           |     |                              |
| $V_{OH}$ High-level output voltage  | $R_L = 10\ \text{k}\Omega$                                   | 25°C       | 4 4.3    |           |          | 4 4.3     |          |           | 4 4.3     |           |     | V                            |
|   |  | Full range | 3.8      |           |          | 3.8       |          |           | 3.8       |           |     |                              |
| $V_{OL}$ Low-level output voltage   |  | 25°C       | 0.7 0.8  |           |          | 0.7 0.8   |          |           | 0.7 0.8   |           |     | V                            |
|   |  | Full range | 0.95     |           |          | 0.95      |          |           | 0.95      |           |     |                              |
| $A_{VD}$ Large-signal differential voltage amplification                        | $V_O = 1.4\text{ V to }4\text{ V}, R_L = 10\ \text{k}\Omega$ | 25°C       | 0.3 1.5  |           |          | 0.4 1.5   |          |           | 0.5 1.5   |           |     | $\text{V}/\mu\text{V}$       |
|   |  | Full range | 0.1      |           |          | 0.1       |          |           | 0.1       |           |     |                              |
| CMRR Common-mode rejection ratio  | $V_{IC} = V_{ICR\text{min}}, R_S = 50\ \Omega$               | 25°C       | 85 100   |           |          | 87 102    |          |           | 90 105    |           |     | dB                           |
|   |  | Full range | 80       |           |          | 82        |          |           | 85        |           |     |                              |
| $k_{SVR}$ Supply-voltage rejection ratio ( $\Delta V_{CC\pm} / \Delta V_{IO}$ ) | $V_{CC} = 5\text{ V to }30\text{ V}$                         | 25°C       | 100 115  |           |          | 103 118   |          |           | 105 120   |           |     | dB                           |
|   |  | Full range | 95       |           |          | 98        |          |           | 100       |           |     |                              |
| $I_{CC}$ Supply current   | $V_O = 2.5\text{ V},$ No load                                | 25°C       | 450 600  |           |          | 450 600   |          |           | 450 600   |           |     | $\mu\text{A}$                |
|   |  | Full range | 600      |           |          | 600       |          |           | 600       |           |     |                              |
| $\Delta I_{CC}$ Supply current change over operating temperature range          |  | Full range | 37       |           |          | 37        |          |           | 37        |           |     | $\mu\text{A}$                |

† Full range is  $-55^\circ\text{C}$  to  $125^\circ\text{C}$ .

NOTE 4: Typical values are based on the input offset voltage shift observed through 168 hours of operating life test at  $T_A = 150^\circ\text{C}$  extrapolated to  $T_A = 25^\circ\text{C}$  using the Arrhenius equation and assuming an activation energy of 0.96 eV.

勝特力材料 886-3-5753170  
 勝特力电子(上海) 86-21-34970699  
 勝特力电子(深圳) 86-755-83298787  
[Http://www.100y.com.tw](http://www.100y.com.tw)

**TLE2022 electrical characteristics at specified free-air temperature,  $V_{CC} = \pm 15$  V (unless otherwise noted)**

| PARAMETER   | TEST CONDITIONS                                 | $T_A$ †    | TLE2022M    |             |     | TLE2022AM   |             |     | TLE2022BM   |             |            | UNIT       |
|---|---|------------|-------------|-------------|-----|-------------|-------------|-----|-------------|-------------|------------|------------|
|   |   |            | MIN         | TYP         | MAX | MIN         | TYP         | MAX | MIN         | TYP         | MAX        |            |
| $V_{IO}$ Input offset voltage   |   | 25°C       | 150         | 500         |     | 120         | 300         |     | 70          | 150         | $\mu$ V    |            |
|   |   | Full range |             | 700         |     | 450         |             | 300 |             |             |            |            |
| $\alpha_{VIO}$ Temperature coefficient of input offset voltage                  |   | Full range | 2           |             |     | 2           |             |     | 2           |             |            | $\mu$ V/°C |
| Input offset voltage long-term drift (see Note 4)                               | $V_{IC} = 0,$<br>$R_S = 50 \Omega$              | 25°C       | 0.006       |             |     | 0.006       |             |     | 0.006       |             |            | $\mu$ V/mo |
| $I_{IO}$ Input offset current   |   | 25°C       | 0.5         | 6           |     | 0.4         | 6           |     | 0.3         | 6           | nA         |            |
|   |   | Full range |             | 10          |     | 10          |             | 10  |             |             |            |            |
| $I_{IB}$ Input bias current   |   | 25°C       | 35          | 70          |     | 33          | 70          |     | 30          | 70          | nA         |            |
|   |   | Full range |             | 90          |     | 90          |             | 90  |             |             |            |            |
| $V_{ICR}$ Common-mode input voltage range                                       | $R_S = 50 \Omega$                               | 25°C       | -15 to 13.5 | -15.3 to 14 |     | -15 to 13.5 | -15.3 to 14 |     | -15 to 13.5 | -15.3 to 14 | V          |            |
|   |   | Full range | -15 to 13.2 |             |     | -15 to 13.2 |             |     | -15 to 13.2 |             |            |            |
| $V_{OM+}$ Maximum positive peak output voltage swing                            | $R_L = 10 \text{ k}\Omega$                      | 25°C       | 14          | 14.3        |     | 14          | 14.3        |     | 14          | 14.3        | V          |            |
|   |   | Full range | 13.9        |             |     | 13.9        |             |     | 13.9        |             |            |            |
| $V_{OM-}$ Maximum negative peak output voltage swing                            | $R_L = 10 \text{ k}\Omega$                      | 25°C       | -13.7       | -14.1       |     | -13.7       | -14.1       |     | -13.7       | -14.1       | V          |            |
|   |   | Full range | -13.6       |             |     | -13.6       |             |     | -13.6       |             |            |            |
| $A_{VD}$ Large-signal differential voltage amplification                        | $V_O = \pm 10$ V,<br>$R_L = 10 \text{ k}\Omega$ | 25°C       | 0.8         | 4           |     | 1           | 7           |     | 1.5         | 10          | V/ $\mu$ V |            |
|   |   | Full range | 0.8         |             |     | 1           |             |     | 1.5         |             |            |            |
| CMRR Common-mode rejection ratio  | $V_{IC} = V_{ICRmin},$<br>$R_S = 50 \Omega$     | 25°C       | 95          | 106         |     | 97          | 109         |     | 100         | 112         | dB         |            |
|   |   | Full range | 91          |             |     | 93          |             |     | 96          |             |            |            |
| $k_{SVR}$ Supply-voltage rejection ratio ( $\Delta V_{CC\pm} / \Delta V_{IO}$ ) | $V_{CC\pm} = \pm 2.5$ V to $\pm 15$ V           | 25°C       | 100         | 115         |     | 103         | 118         |     | 105         | 120         | dB         |            |
|   |   | Full range | 95          |             |     | 98          |             |     | 100         |             |            |            |
| $I_{CC}$ Supply current   | $V_O = 0,$<br>No load                           | 25°C       | 550         | 700         |     | 550         | 700         |     | 550         | 700         | $\mu$ A    |            |
|   |   | Full range |             | 700         |     | 700         |             | 700 |             |             |            |            |
| $\Delta I_{CC}$ Supply current change over operating temperature range          |   | Full range | 60          |             |     | 60          |             |     | 60          |             |            | $\mu$ A    |

† Full range is 0°C to 70°C.

NOTE 4: Typical values are based on the input offset voltage shift observed through 168 hours of operating life test at  $T_A = 150^\circ\text{C}$  extrapolated to  $T_A = 25^\circ\text{C}$  using the Arrhenius equation and assuming an activation energy of 0.96 eV.

勝特力材料 886-3-5753170  
 勝特力电子(上海) 86-21-34970699  
 勝特力电子(深圳) 86-755-83298787  
[Http://www.100y.com.tw](http://www.100y.com.tw)

TLE2024 electrical characteristics at specified free-air temperature,  $V_{CC} = 5\text{ V}$  (unless otherwise noted)

| PARAMETER   | TEST CONDITIONS   | $T_A$ †    | TLE2024M |           |          | TLE2024AM |          |             | TLE2024BM              |     |     | UNIT                         |
|---|---|------------|----------|-----------|----------|-----------|----------|-------------|------------------------|-----|-----|------------------------------|
|   |   |            | MIN      | TYP       | MAX      | MIN       | TYP      | MAX         | MIN                    | TYP | MAX |                              |
| $V_{IO}$ Input offset voltage   | $V_{IC} = 0, R_S = 50\ \Omega$                                  | 25°C       | 1100     |           |          | 850       |          |             | 600                    |     |     | $\mu\text{V}$                |
|   |   | Full range | 1300     |           |          | 1050      |          |             | 800                    |     |     |                              |
| $\alpha_{VIO}$ Temperature coefficient of input offset voltage                |   | Full range | 2        |           |          | 2         |          |             | 2                      |     |     | $\mu\text{V}/^\circ\text{C}$ |
| Input offset voltage long-term drift (see Note 4)                             |   | 25°C       | 0.005    |           |          | 0.005     |          |             | 0.005                  |     |     | $\mu\text{V}/\text{mo}$      |
| $I_{IO}$ Input offset current   |   | 25°C       | 0.6      | 6         | 0.5      | 6         | 0.4      | 6           | $\text{nA}$            |     |     |                              |
|   |   | Full range | 10       |           |          | 10        |          |             |                        |     |     |                              |
| $I_{IB}$ Input bias current   | 25°C  | 45         | 70       | 40        | 70       | 35        | 70       | $\text{nA}$ |                        |     |     |                              |
|   | Full range  | 90         |          |           | 90       |           |          |             |                        |     |     |                              |
| $V_{ICR}$ Common-mode input voltage range                                     | $R_S = 50\ \Omega$  | 25°C       | 0 to 3.5 | -0.3 to 4 | 0 to 3.5 | -0.3 to 4 | 0 to 3.5 | -0.3 to 4   | $\text{V}$             |     |     |                              |
|   |   | Full range | 0 to 3.2 |           | 0 to 3.2 |           | 0 to 3.2 |             |                        |     |     |                              |
| $V_{OM+}$ Maximum positive peak output voltage swing                          | $R_L = 10\ \text{k}\Omega$                                      | 25°C       | 3.9      | 4.2       | 3.9      | 4.2       | 4        | 4.3         | $\text{V}$             |     |     |                              |
|   |   | Full range | 3.7      |           | 3.7      |           | 3.8      |             |                        |     |     |                              |
| $V_{OM-}$ Maximum negative peak output voltage swing                          |   | 25°C       | 0.7      | 0.8       | 0.7      | 0.8       | 0.7      | 0.8         | $\text{V}$             |     |     |                              |
|   |   | Full range | 0.95     |           | 0.95     |           | 0.95     |             |                        |     |     |                              |
| $A_{VD}$ Large-signal differential voltage amplification                      | $V_O = 1.4\ \text{V to } 4\ \text{V}, R_L = 10\ \text{k}\Omega$ | 25°C       | 0.2      | 1.5       | 0.3      | 1.5       | 0.4      | 1.5         | $\text{V}/\mu\text{V}$ |     |     |                              |
|   |   | Full range | 0.1      |           | 0.1      |           | 0.1      |             |                        |     |     |                              |
| CMRR Common-mode rejection ratio  | $V_{IC} = V_{ICRmin}, R_S = 50\ \Omega$                         | 25°C       | 80       | 90        | 82       | 92        | 85       | 95          | $\text{dB}$            |     |     |                              |
|   |   | Full range | 80       |           | 82       |           | 85       |             |                        |     |     |                              |
| $k_{SVR}$ Supply-voltage rejection ratio ( $\Delta V_{CC\pm}/\Delta V_{IO}$ ) | $V_{CC\pm} = \pm 2.5\ \text{V to } \pm 15\ \text{V}$            | 25°C       | 98       | 112       | 100      | 115       | 103      | 117         | $\text{dB}$            |     |     |                              |
|   |   | Full range | 93       |           | 95       |           | 98       |             |                        |     |     |                              |
| $I_{CC}$ Supply current   | $V_O = 0, \text{ No load}$                                      | 25°C       | 800      | 1200      | 800      | 1200      | 800      | 1200        | $\mu\text{A}$          |     |     |                              |
|   |   | Full range | 1200     |           |          | 1200      |          |             |                        |     |     |                              |
| $\Delta I_{CC}$ Supply current change over operating temperature range        |   | Full range | 50       |           |          | 50        |          |             | $\mu\text{A}$          |     |     |                              |

† Full range is  $-55^\circ\text{C}$  to  $125^\circ\text{C}$ .

NOTE 4: Typical values are based on the input offset voltage shift observed through 168 hours of operating life test at  $T_A = 150^\circ\text{C}$  extrapolated to  $T_A = 25^\circ\text{C}$  using the Arrhenius equation and assuming an activation energy of 0.96 eV.

勝特力材料 886-3-5753170  
 勝特力电子(上海) 86-21-34970699  
 勝特力电子(深圳) 86-755-83298787  
[Http://www.100y.com.tw](http://www.100y.com.tw)

**TLE2024 electrical characteristics at specified free-air temperature,  $V_{CC} = \pm 15\text{ V}$  (unless otherwise noted)**

| PARAMETER   | TEST CONDITIONS                                      | $T_A^\dagger$                                      | TLE2024M   |             |             | TLE2024AM   |             |             | TLE2024BM     |                        |     | UNIT                         |
|---|--|--|------------|-------------|-------------|-------------|-------------|-------------|---------------|------------------------|-----|------------------------------|
|   |  |  | MIN        | TYP         | MAX         | MIN         | TYP         | MAX         | MIN           | TYP                    | MAX |                              |
| $V_{IO}$ Input offset voltage   | $V_{IC} = 0, R_S = 50\ \Omega$                       | 25°C   | 1000       |             |             | 750         |             |             | 500           |                        |     | $\mu\text{V}$                |
|   |  | Full range   | 1200       |             |             | 950         |             |             | 700           |                        |     |                              |
| $\alpha_{VIO}$ Temperature coefficient of input offset voltage                |  | Full range   | 2          |             |             | 2           |             |             | 2             |                        |     | $\mu\text{V}/^\circ\text{C}$ |
| Input offset voltage long-term drift (see Note 4)                             |  | 25°C   | 0.006      |             |             | 0.006       |             |             | 0.006         |                        |     | $\mu\text{V}/\text{mo}$      |
| $I_{IO}$ Input offset current   |  | 25°C   | 0.6        | 6           | 0.5         | 6           | 0.4         | 6           | $\text{nA}$   |                        |     |                              |
|   |  | Full range   | 10         |             |             | 10          |             |             |               | 10                     |     |                              |
| $I_{IB}$ Input bias current   |  | 25°C   | 50         | 70          | 45          | 70          | 40          | 70          | $\text{nA}$   |                        |     |                              |
|   |  | Full range   | 90         |             |             | 90          |             |             |               | 90                     |     |                              |
| $V_{ICR}$ Common-mode input voltage range                                     |  | $R_S = 50\ \Omega$                                 | 25°C       | -15 to 13.5 | -15.3 to 14 | -15 to 13.5 | -15.3 to 14 | -15 to 13.5 | -15.3 to 14   | $\text{V}$             |     |                              |
|   |  |  | Full range | -15 to 13.2 | -15.3 to 14 | -15 to 13.2 | -15.3 to 14 | -15 to 13.2 | -15.3 to 14   |                        |     |                              |
| $V_{OM+}$ Maximum positive peak output voltage swing                          | $R_L = 10\ \text{k}\Omega$                           | 25°C   | 13.8       | 14.1        | 13.9        | 14.2        | 14          | 14.3        | $\text{V}$    |                        |     |                              |
|   |  | Full range   | 13.7       |             |             | 13.7        |             |             |               | 13.8                   |     |                              |
| $V_{OM-}$ Maximum negative peak output voltage swing                          |  | 25°C   | -13.7      | -14.1       | -13.7       | -14.1       | -13.7       | -14.1       | $\text{V}$    |                        |     |                              |
|   |  | Full range   | -13.6      |             |             | -13.6       |             |             |               | -13.6                  |     |                              |
| $A_{VD}$ Large-signal differential voltage amplification                      |  | $V_O = \pm 10\ \text{V}, R_L = 10\ \text{k}\Omega$ | 25°C       | 0.4         | 2           | 0.8         | 4           | 1           | 7             | $\text{V}/\mu\text{V}$ |     |                              |
|   |  |  | Full range | 0.4         |             |             | 0.8         |             |               |                        | 1   |                              |
| CMRR Common-mode rejection ratio  | $V_{IC} = V_{ICR\text{min}}, R_S = 50\ \Omega$       | 25°C   | 92         | 102         | 94          | 105         | 97          | 108         | dB            |                        |     |                              |
|   |  | Full range   | 88         |             |             | 90          |             |             |               | 93                     |     |                              |
| $k_{SVR}$ Supply-voltage rejection ratio ( $\Delta V_{CC\pm}/\Delta V_{IO}$ ) | $V_{CC\pm} = \pm 2.5\ \text{V to } \pm 15\ \text{V}$ | 25°C   | 98         | 112         | 100         | 115         | 103         | 117         | dB            |                        |     |                              |
|   |  | Full range   | 93         |             |             | 95          |             |             |               | 98                     |     |                              |
| $I_{CC}$ Supply current   | $V_O = 0, \text{ No load}$                           | 25°C   | 1050       | 1400        | 1050        | 1400        | 1050        | 1400        | $\mu\text{A}$ |                        |     |                              |
|   |  | Full range   | 1400       |             |             | 1400        |             |             |               | 1400                   |     |                              |
| $\Delta I_{CC}$ Supply current change over operating temperature range        |  | Full range   | 85         |             |             | 85          |             |             | 85            |                        |     | $\mu\text{A}$                |

$^\dagger$  Full range is  $-55^\circ\text{C}$  to  $125^\circ\text{C}$ .

NOTE 4: Typical values are based on the input offset voltage shift observed through 168 hours of operating life test at  $T_A = 150^\circ\text{C}$  extrapolated to  $T_A = 25^\circ\text{C}$  using the Arrhenius equation and assuming an activation energy of 0.96 eV.

**勝特力材料 886-3-5753170**  
**勝特力电子(上海) 86-21-34970699**  
**勝特力电子(深圳) 86-755-83298787**  
[Http://www.100y.com.tw](http://www.100y.com.tw)

**TLE2021 operating characteristics,  $V_{CC} = 5\text{ V}$ ,  $T_A = 25^\circ\text{C}$**

| PARAMETER   | TEST CONDITIONS                               | $T_A$   | C SUFFIX |       |     | I SUFFIX |       |     | M SUFFIX |      |     | UNIT |                  |
|-------------|---|---|----------|-------|-----|----------|-------|-----|----------|------|-----|------|------------------|
|             |   |   | MIN      | TYP   | MAX | MIN      | TYP   | MAX | MIN      | TYP  | MAX |      |                  |
| SR          | Slew rate at unity gain                       | $V_O = 1\text{ V to }3\text{ V}$ , See Figure 1 | 25°C     | 0.5   |     |          | 0.5   |     |          | 0.5  |     |      | V/ $\mu\text{s}$ |
| $V_n$       | Equivalent input noise voltage (see Figure 2) | $f = 10\text{ Hz}$                              | 25°C     | 21 50 |     |          | 21 50 |     |          | 21   |     |      | nV/Hz            |
|             |   | $f = 1\text{ kHz}$                              | 25°C     | 17 30 |     |          | 17 30 |     |          | 17   |     |      |                  |
| $V_{N(PP)}$ | Peak-to-peak equivalent input noise voltage   | $f = 0.1\text{ to }1\text{ Hz}$                 | 25°C     | 0.16  |     |          | 0.16  |     |          | 0.16 |     |      | $\mu\text{V}$    |
|             |   | $f = 0.1\text{ to }10\text{ Hz}$                | 25°C     | 0.47  |     |          | 0.47  |     |          | 0.47 |     |      |                  |
| $I_n$       | Equivalent input noise current                |   | 25°C     | 0.09  |     |          | 0.09  |     |          | 0.9  |     |      | pA/Hz            |
| $B_1$       | Unity-gain bandwidth                          | See Figure 3                                    | 25°C     | 1.2   |     |          | 1.2   |     |          | 1.2  |     |      | MHz              |
| $\phi_m$    | Phase margin at unity gain                    | See Figure 3                                    | 25°C     | 42°   |     |          | 42°   |     |          | 42°  |     |      |                  |

**TLE2021 operating characteristics at specified free-air temperature,  $V_{CC} = \pm 15\text{ V}$**

| PARAMETER   | TEST CONDITIONS                               | $T_A^\dagger$                                   | C SUFFIX |       |      | I SUFFIX |       |      | M SUFFIX |      |      | UNIT             |               |
|-------------|---|---|----------|-------|------|----------|-------|------|----------|------|------|------------------|---------------|
|             |   |   | MIN      | TYP   | MAX  | MIN      | TYP   | MAX  | MIN      | TYP  | MAX  |                  |               |
| SR          | Slew rate at unity gain                       | $V_O = 1\text{ V to }3\text{ V}$ , See Figure 1 | 25°C     | 0.45  | 0.65 |          | 0.45  | 0.65 |          | 0.45 | 0.65 | V/ $\mu\text{s}$ |               |
|             |   | Full range                                      |          | 0.45  |      |          | 0.42  |      |          | 0.45 |      |                  |               |
| $V_n$       | Equivalent input noise voltage (see Figure 2) | $f = 10\text{ Hz}$                              | 25°C     | 19 50 |      |          | 19 50 |      |          | 19   |      |                  | nV/Hz         |
|             |   | $f = 1\text{ kHz}$                              | 25°C     | 15 30 |      |          | 15 30 |      |          | 15   |      |                  |               |
| $V_{N(PP)}$ | Peak-to-peak equivalent input noise voltage   | $f = 0.1\text{ to }1\text{ Hz}$                 | 25°C     | 0.16  |      |          | 0.16  |      |          | 0.16 |      |                  | $\mu\text{V}$ |
|             |   | $f = 0.1\text{ to }10\text{ Hz}$                | 25°C     | 0.47  |      |          | 0.47  |      |          | 0.47 |      |                  |               |
| $I_n$       | Equivalent input noise current                |   | 25°C     | 0.09  |      |          | 0.09  |      |          | 0.09 |      |                  | pA/Hz         |
| $B_1$       | Unity-gain bandwidth                          | See Figure 3                                    | 25°C     | 2     |      |          | 2     |      |          | 2    |      |                  | MHz           |
| $\phi_m$    | Phase margin at unity gain                    | See Figure 3                                    | 25°C     | 46°   |      |          | 46°   |      |          | 46°  |      |                  |               |

$^\dagger$  Full range is 0°C to 70°C for the C-suffix devices, -40°C to 85°C for the I-suffix devices, and -55°C to 125°C for the M-suffix devices.

勝特力材料 886-3-5753170  
 勝特力电子(上海) 86-21-34970699  
 勝特力电子(深圳) 86-755-83298787  
[Http://www.100y.com.tw](http://www.100y.com.tw)

**TLE2022 operating characteristics,  $V_{CC} = 5\text{ V}$ ,  $T_A = 25^\circ\text{C}$**

| PARAMETER   | TEST CONDITIONS                               | C SUFFIX  |     |     | I SUFFIX |     |     | M SUFFIX |     |     | UNIT                         |
|-------------|---|---|-----|-----|----------|-----|-----|----------|-----|-----|------------------------------|
|             |   | MIN   | TYP | MAX | MIN      | TYP | MAX | MIN      | TYP | MAX |                              |
| SR          | Slew rate at unity gain                       | $V_O = 1\text{ V to }3\text{ V}$ , See Figure 1 |     |     | 0.5      |     |     | 0.5      |     |     | $\text{V}/\mu\text{s}$       |
| $V_n$       | Equivalent input noise voltage (see Figure 2) | f = 10 Hz                                       |     |     | 21 50    |     |     | 21 50    |     |     | $\text{nV}/\sqrt{\text{Hz}}$ |
|             |   | f = 1 kHz                                       |     |     | 17 30    |     |     | 17 30    |     |     |                              |
| $V_{N(PP)}$ | Peak-to-peak equivalent input noise voltage   | f = 0.1 to 1 Hz                                 |     |     | 0.16     |     |     | 0.16     |     |     | $\mu\text{V}$                |
|             |   | f = 0.1 to 10 Hz                                |     |     | 0.47     |     |     | 0.47     |     |     |                              |
| $I_n$       | Equivalent input noise current                |   |     |     | 0.1      |     |     | 0.1      |     |     | $\text{pA}/\sqrt{\text{Hz}}$ |
| $B_1$       | Unity-gain bandwidth                          | See Figure 3                                    |     |     | 1.7      |     |     | 1.7      |     |     | MHz                          |
| $\phi_m$    | Phase margin at unity gain                    | See Figure 3                                    |     |     | 47°      |     |     | 47°      |     |     |                              |

**TLE2022 operating characteristics at specified free-air temperature,  $V_{CC} = \pm 15\text{ V}$**

| PARAMETER   | TEST CONDITIONS                               | $T_A^\dagger$                          | C SUFFIX   |      |      | I SUFFIX |      |      | M SUFFIX |      |                              | UNIT                         |
|-------------|---|--|------------|------|------|----------|------|------|----------|------|------------------------------|------------------------------|
|             |   |  | MIN        | TYP  | MAX  | MIN      | TYP  | MAX  | MIN      | TYP  | MAX                          |                              |
| SR          | Slew rate at unity gain                       | $V_O = \pm 10\text{ V}$ , See Figure 1 | 25°C       | 0.45 | 0.65 |          | 0.45 | 0.65 |          | 0.45 | 0.65                         | $\text{V}/\mu\text{s}$       |
|             |   |  | Full range | 0.45 |      |          | 0.42 |      |          | 0.4  |                              |                              |
| $V_n$       | Equivalent input noise voltage (see Figure 2) |  | 25°C       |      | 19   | 50       |      | 19   | 50       |      | 19                           | $\text{nV}/\sqrt{\text{Hz}}$ |
|             |   |  | 25°C       |      | 15   | 30       |      | 15   | 30       |      | 15                           |                              |
| $V_{N(PP)}$ | Peak-to-peak equivalent input noise voltage   |  | 25°C       |      | 0.16 |          |      | 0.16 |          |      | 0.16                         | $\mu\text{V}$                |
|             |   |  | 25°C       |      | 0.47 |          |      | 0.47 |          |      | 0.47                         |                              |
| $I_n$       | Equivalent input noise current                |  | 25°C       |      | 0.1  |          |      | 0.1  |          |      | $\text{pA}/\sqrt{\text{Hz}}$ |                              |
| $B_1$       | Unity-gain bandwidth                          |  | 25°C       |      | 2.8  |          |      | 2.8  |          |      | MHz                          |                              |
| $\phi_m$    | Phase margin at unity gain                    |  | 25°C       |      | 52°  |          |      | 52°  |          |      |                              |                              |

† Full range is 0°C to 70°C.

勝特力材料 886-3-5753170  
 勝特力电子(上海) 86-21-34970699  
 勝特力电子(深圳) 86-755-83298787  
[Http://www.100y.com.tw](http://www.100y.com.tw)

**TLE2024 operating characteristics,  $V_{CC} = 5\text{ V}$ ,  $T_A = 25^\circ\text{C}$**

| PARAMETER   | TEST CONDITIONS                               | C SUFFIX  |     |     | I SUFFIX |     |     | M SUFFIX |     |     | UNIT                         |
|-------------|---|---|-----|-----|----------|-----|-----|----------|-----|-----|------------------------------|
|             |   | MIN   | TYP | MAX | MIN      | TYP | MAX | MIN      | TYP | MAX |                              |
| SR          | Slew rate at unity gain                       | $V_O = 1\text{ V to }3\text{ V}$ , See Figure 1 |     |     | 0.5      |     |     | 0.5      |     |     | $\text{V}/\mu\text{s}$       |
| $V_n$       | Equivalent input noise voltage (see Figure 2) | $f = 10\text{ Hz}$                              |     |     | 21       |     |     | 21       |     |     | $\text{nV}/\sqrt{\text{Hz}}$ |
|             |   | $f = 1\text{ kHz}$                              |     |     | 17       |     |     | 17       |     |     |                              |
| $V_{N(PP)}$ | Peak-to-peak equivalent input noise voltage   | $f = 0.1\text{ to }1\text{ Hz}$                 |     |     | 0.16     |     |     | 0.16     |     |     | $\mu\text{V}$                |
|             |   | $f = 0.1\text{ to }10\text{ Hz}$                |     |     | 0.47     |     |     | 0.47     |     |     |                              |
| $I_n$       | Equivalent input noise current                |   |     |     | 0.1      |     |     | 0.1      |     |     | $\text{pA}/\sqrt{\text{Hz}}$ |
| $B_1$       | Unity-gain bandwidth                          | See Figure 3                                    |     |     | 1.7      |     |     | 1.7      |     |     | MHz                          |
| $\phi_m$    | Phase margin at unity gain                    | See Figure 3                                    |     |     | 47°      |     |     | 47°      |     |     |                              |

**TLE2024 operating characteristics at specified free-air temperature,  $V_{CC} = \pm 15\text{ V}$  (unless otherwise noted)**

| PARAMETER   | TEST CONDITIONS                               | $T_A^\dagger$                          | C SUFFIX   |     |     | I SUFFIX |     |     | M SUFFIX |     |     | UNIT                         |
|-------------|---|--|------------|-----|-----|----------|-----|-----|----------|-----|-----|------------------------------|
|             |   |  | MIN        | TYP | MAX | MIN      | TYP | MAX | MIN      | TYP | MAX |                              |
| SR          | Slew rate at unity gain                       | $V_O = \pm 10\text{ V}$ , See Figure 1 | 25°C       |     |     | 0.45     |     |     | 0.45     |     |     | $\text{V}/\mu\text{s}$       |
|             |   |  | Full range |     |     | 0.45     |     |     | 0.42     |     |     |                              |
| $V_n$       | Equivalent input noise voltage (see Figure 2) |  | 25°C       |     |     | 19       |     |     | 19       |     |     | $\text{nV}/\sqrt{\text{Hz}}$ |
|             |   |  | 25°C       |     |     | 15       |     |     | 15       |     |     |                              |
| $V_{N(PP)}$ | Peak-to-peak equivalent input noise voltage   |  | 25°C       |     |     | 0.16     |     |     | 0.16     |     |     | $\mu\text{V}$                |
|             |   |  | 25°C       |     |     | 0.47     |     |     | 0.47     |     |     |                              |
| $I_n$       | Equivalent input noise current                |  | 25°C       |     |     | 0.1      |     |     | 0.1      |     |     | $\text{pA}/\sqrt{\text{Hz}}$ |
| $B_1$       | Unity-gain bandwidth                          |  | 25°C       |     |     | 2.8      |     |     | 2.8      |     |     | MHz                          |
| $\phi_m$    | Phase margin at unity gain                    |  | 25°C       |     |     | 52°      |     |     | 52°      |     |     |                              |

† Full range is 0°C to 70°C.

勝特力材料 886-3-5753170  
 勝特力电子(上海) 86-21-34970699  
 勝特力电子(深圳) 86-755-83298787  
[Http://www.100y.com.tw](http://www.100y.com.tw)

# TLE202x, TLE202xA, TLE202xB, TLE202xY EXCALIBUR HIGH-SPEED LOW-POWER PRECISION OPERATIONAL AMPLIFIERS

SLOS191 – FEBRUARY 1997

## TLE2021Y electrical characteristics at $V_{CC} = 5\text{ V}$ , $T_A = 25^\circ\text{C}$ (unless otherwise noted)

| PARAMETER   | TEST CONDITIONS  | TLE2021Y        |     |     | UNIT                    |
|---|--|-----------------|-----|-----|-------------------------|
|   |  | MIN             | TYP | MAX |                         |
| $V_{IO}$ Input offset voltage   | $V_{IC} = 0$ , $R_S = 50\ \Omega$                                | 150             |     |     | $\mu\text{V}$           |
| Input offset voltage long-term drift (see Note 4)                             |  | 0.005           |     |     | $\mu\text{V}/\text{mo}$ |
| $I_{IO}$ Input offset current   |  | 0.5             |     |     | nA                      |
| $I_{IB}$ Input bias current   |  | 35              |     |     | nA                      |
| $V_{ICR}$ Common-mode input voltage range                                     | $R_S = 50\ \Omega$   | -0.3<br>to<br>4 |     |     | V                       |
| $V_{OH}$ Maximum high-level output voltage                                    | $R_L = 10\ \text{k}\Omega$                                       | 4.3             |     |     | V                       |
| $V_{OL}$ Maximum low-level output voltage                                     |  | 0.7             |     |     | V                       |
| $A_{VD}$ Large-signal differential voltage amplification                      | $V_O = 1.4\ \text{to}\ 4\ \text{V}$ , $R_L = 10\ \text{k}\Omega$ | 1.5             |     |     | $\text{V}/\mu\text{V}$  |
| CMRR Common-mode rejection ratio  | $V_{IC} = V_{ICR}\ \text{min}$ , $R_S = 50\ \Omega$              | 100             |     |     | dB                      |
| $k_{SVR}$ Supply-voltage rejection ratio ( $\Delta V_{CC\pm}/\Delta V_{IO}$ ) | $V_{CC} = 5\ \text{V}\ \text{to}\ 30\ \text{V}$                  | 115             |     |     | dB                      |
| $I_{CC}$ Supply current   | $V_O = 2.5\ \text{V}$ , No load                                  | 400             |     |     | $\mu\text{A}$           |

NOTE 4: Typical values are based on the input offset voltage shift observed through 168 hours of operating life test at  $T_A = 150^\circ\text{C}$  extrapolated to  $T_A = 25^\circ\text{C}$  using the Arrhenius equation and assuming an activation energy of 0.96 eV.

## TLE2021Y operating characteristics at $V_{CC} = 5\text{ V}$ , $T_A = 25^\circ\text{C}$

| PARAMETER   | TEST CONDITIONS                             | TLE2021Y |     |     | UNIT                         |
|---|---|----------|-----|-----|------------------------------|
|   |   | MIN      | TYP | MAX |                              |
| SR Slew rate at unity gain                              | $V_O = 1\ \text{V}\ \text{to}\ 3\ \text{V}$ | 0.5      |     |     | $\text{V}/\mu\text{s}$       |
| $V_n$ Equivalent input noise voltage                    | $f = 10\ \text{Hz}$                         | 21       |     |     | $\text{nV}/\sqrt{\text{Hz}}$ |
|   | $f = 1\ \text{kHz}$                         | 17       |     |     |                              |
| $V_{N(PP)}$ Peak-to-peak equivalent input noise voltage | $f = 0.1\ \text{to}\ 1\ \text{Hz}$          | 0.16     |     |     | $\mu\text{V}$                |
|   | $f = 0.1\ \text{to}\ 10\ \text{Hz}$         | 0.47     |     |     |                              |
| $I_n$ Equivalent input noise current                    |   | 0.1      |     |     | $\text{pA}/\sqrt{\text{Hz}}$ |
| $B_1$ Unity-gain bandwidth                              |   | 1.7      |     |     | MHz                          |
| $\phi_m$ Phase margin at unity gain                     |   | 47°      |     |     |                              |

勝特力材料 886-3-5753170  
 勝特力电子(上海) 86-21-34970699  
 勝特力电子(深圳) 86-755-83298787  
[Http://www.100y.com.tw](http://www.100y.com.tw)

# TLE202x, TLE202xA, TLE202xB, TLE202xY EXCALIBUR HIGH-SPEED LOW-POWER PRECISION OPERATIONAL AMPLIFIERS

SLOS191 – FEBRUARY 1997

## TLE2022Y electrical characteristics, $V_{CC} = 5\text{ V}$ , $T_A = 25^\circ\text{C}$ (unless otherwise noted)

| PARAMETER   | TEST CONDITIONS  | TLE2022Y |                 |     | UNIT                    |
|---|--|----------|-----------------|-----|-------------------------|
|   |  | MIN      | TYP             | MAX |                         |
| $V_{IO}$ Input offset voltage   | $V_{IC} = 0$ ,<br>$R_S = 50\ \Omega$                             |          | 150             | 600 | $\mu\text{V}$           |
| Input offset voltage long-term drift (see Note 4)                             |  |          | 0.005           |     | $\mu\text{V}/\text{mo}$ |
| $I_{IO}$ Input offset current   |  |          | 0.5             |     | nA                      |
| $I_{IB}$ Input bias current   |  |          | 35              |     | nA                      |
| $V_{ICR}$ Common-mode input voltage range                                     | $R_S = 50\ \Omega$   |          | -0.3<br>to<br>4 |     | V                       |
| $V_{OH}$ Maximum high-level output voltage                                    | $R_L = 10\ \text{k}\Omega$                                       |          | 4.3             |     | V                       |
| $V_{OL}$ Maximum low-level output voltage                                     |  |          | 0.7             |     | V                       |
| $A_{VD}$ Large-signal differential voltage amplification                      | $V_O = 1.4\text{ to }4\text{ V}$ ,<br>$R_L = 10\ \text{k}\Omega$ |          | 1.5             |     | $\text{V}/\mu\text{V}$  |
| CMRR Common-mode rejection ratio  | $V_{IC} = V_{ICR}\ \text{min}$ ,<br>$R_S = 50\ \Omega$           |          | 100             |     | dB                      |
| $k_{SVR}$ Supply-voltage rejection ratio ( $\Delta V_{CC\pm}/\Delta V_{IO}$ ) | $V_{CC} = 5\text{ V to }30\text{ V}$                             |          | 115             |     | dB                      |
| $I_{CC}$ Supply current   | $V_O = 2.5\text{ V}$ ,<br>No load                                |          | 450             |     | $\mu\text{A}$           |

NOTE 4: Typical values are based on the input offset voltage shift observed through 168 hours of operating life test at  $T_A = 150^\circ\text{C}$  extrapolated to  $T_A = 25^\circ\text{C}$  using the Arrhenius equation and assuming an activation energy of 0.96 eV.

## TLE2022Y operating characteristics, $V_{CC} = 5\text{ V}$ , $T_A = 25^\circ\text{C}$

| PARAMETER   | TEST CONDITIONS                                    | TLE2022Y |      |     | UNIT                         |
|---|--|----------|------|-----|------------------------------|
|   |  | MIN      | TYP  | MAX |                              |
| SR Slew rate at unity gain                              | $V_O = 1\text{ V to }3\text{ V}$ ,<br>See Figure 1 |          | 0.5  |     | $\text{V}/\mu\text{s}$       |
| $V_n$ Equivalent input noise voltage (see Figure 2)     | $f = 10\ \text{Hz}$                                |          | 21   |     | $\text{nV}/\sqrt{\text{Hz}}$ |
|   | $f = 1\ \text{kHz}$                                |          | 17   |     |                              |
| $V_{N(PP)}$ Peak-to-peak equivalent input noise voltage | $f = 0.1\text{ to }1\ \text{Hz}$                   |          | 0.16 |     | $\mu\text{V}$                |
|   | $f = 0.1\text{ to }10\ \text{Hz}$                  |          | 0.47 |     |                              |
| $I_n$ Equivalent input noise current                    |  |          | 0.1  |     | $\text{pA}/\sqrt{\text{Hz}}$ |
| $B_1$ Unity-gain bandwidth                              | See Figure 3                                       |          | 1.7  |     | MHz                          |
| $\phi_m$ Phase margin at unity gain                     | See Figure 3                                       |          | 47°  |     |                              |

勝特力材料 886-3-5753170  
 勝特力电子(上海) 86-21-34970699  
 勝特力电子(深圳) 86-755-83298787  
[Http://www.100y.com.tw](http://www.100y.com.tw)

**TLE202x, TLE202xA, TLE202xB, TLE202xY**  
**EXCALIBUR HIGH-SPEED LOW-POWER PRECISION**  
**OPERATIONAL AMPLIFIERS**

SLOS191 – FEBRUARY 1997

**TLE2024Y electrical characteristics,  $V_{CC} = 5\text{ V}$ ,  $T_A = 25^\circ\text{C}$  (unless otherwise noted)**

| PARAMETER  | TEST CONDITIONS   | TLE2024Y |                 |     | UNIT                    |
|--|---|----------|-----------------|-----|-------------------------|
|  |   | MIN      | TYP             | MAX |                         |
| Input offset voltage long-term drift (see Note 4)                          |   |          | 0.005           |     | $\mu\text{V}/\text{mo}$ |
| $I_{IO}$ Input offset current  | $V_{IC} = 0$ , $R_S = 50\ \Omega$                                   |          | 0.6             |     | nA                      |
| $I_{IB}$ Input bias current  |   |          | 45              |     | nA                      |
| $V_{ICR}$ Common-mode input voltage range                                  | $R_S = 50\ \Omega$  |          | -0.3<br>to<br>4 |     | V                       |
| $V_{OH}$ High-level output voltage   | $R_L = 10\ \text{k}\Omega$  |          | 4.2             |     | V                       |
| $V_{OL}$ Low-level output voltage  |   |          | 0.7             |     | V                       |
| $A_{VD}$ Large-signal differential voltage amplification                   | $V_O = 1.4\ \text{V}$ to $4\ \text{V}$ , $R_L = 10\ \text{k}\Omega$ |          | 1.5             |     | $\text{V}/\mu\text{V}$  |
| CMRR Common-mode rejection ratio   | $V_{IC} = V_{ICRmin}$ , $R_S = 50\ \Omega$                          |          | 90              |     | dB                      |
| $k_{SVR}$ Supply-voltage rejection ratio ( $\Delta V_{CC}/\Delta V_{IO}$ ) | $V_{CC} = 5\ \text{V}$ to $30\ \text{V}$                            |          | 112             |     | dB                      |
| $I_{CC}$ Supply current  | $V_O = 2.5\ \text{V}$ , No load                                     |          | 800             |     | $\mu\text{A}$           |

NOTE 4. Typical values are based on the input offset voltage shift observed through 168 hours of operating life test at  $T_A = 150^\circ\text{C}$  extrapolated to  $T_A = 25^\circ\text{C}$  using the Arrhenius equation and assuming an activation energy of 0.96 eV.

**TLE2024Y operating characteristics,  $V_{CC} = 5\ \text{V}$ ,  $T_A = 25^\circ\text{C}$**

| PARAMETER   | TEST CONDITIONS                                     | TLE2024Y |      |     | UNIT                         |
|---|---|----------|------|-----|------------------------------|
|   |   | MIN      | TYP  | MAX |                              |
| SR Slew rate at unity gain                              | $V_O = 1\ \text{V}$ to $3\ \text{V}$ , See Figure 1 |          | 0.5  |     | $\text{V}/\mu\text{s}$       |
| $V_n$ Equivalent input noise voltage (see Figure 2)     | $f = 10\ \text{Hz}$                                 |          | 21   |     | $\text{nV}/\sqrt{\text{Hz}}$ |
|   | $f = 1\ \text{kHz}$                                 |          | 17   |     |                              |
| $V_{N(PP)}$ Peak-to-peak equivalent input noise voltage | $f = 0.1$ to $1\ \text{Hz}$                         |          | 0.16 |     | $\mu\text{V}$                |
|   | $f = 0.1$ to $10\ \text{Hz}$                        |          | 0.47 |     |                              |
| $I_n$ Equivalent input noise current                    |   |          | 0.1  |     | $\text{pA}/\sqrt{\text{Hz}}$ |
| $B_1$ Unity-gain bandwidth                              | See Figure 3  |          | 1.7  |     | MHz                          |
| $\phi_m$ Phase margin at unity gain                     | See Figure 3  |          | 47°  |     |                              |

勝特力材料 886-3-5753170  
 勝特力电子(上海) 86-21-34970699  
 勝特力电子(深圳) 86-755-83298787  
[Http://www.100y.com.tw](http://www.100y.com.tw)

PARAMETER MEASUREMENT INFORMATION

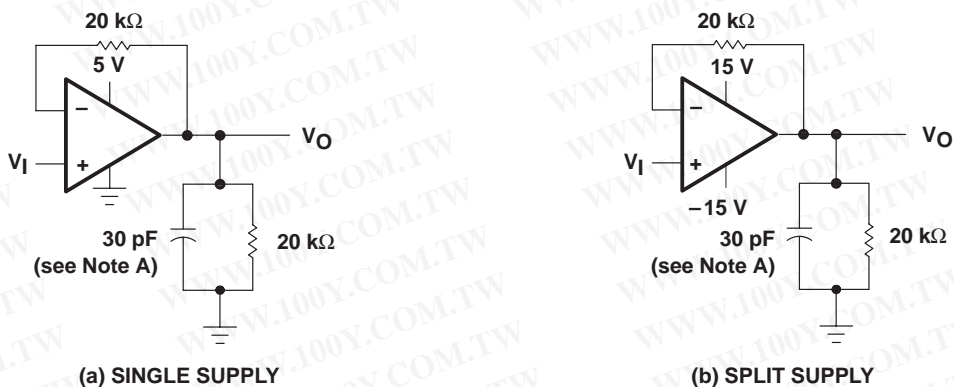

NOTE A:  $C_L$  includes fixture capacitance.

Figure 1. Slew-Rate Test Circuit

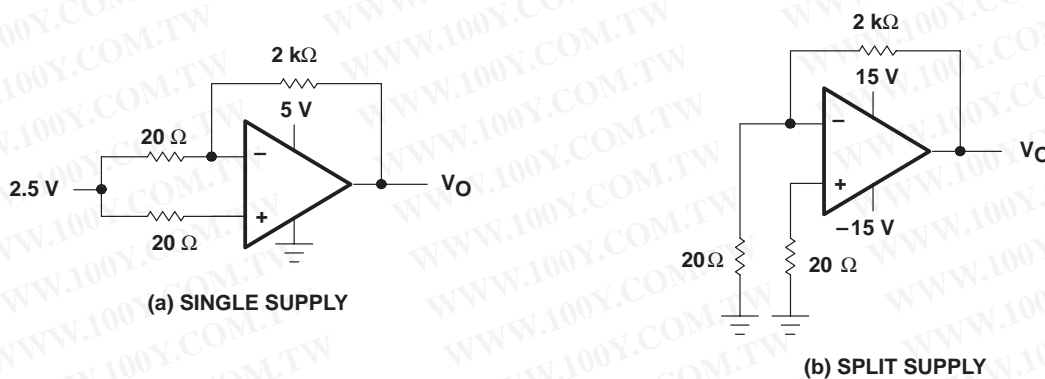
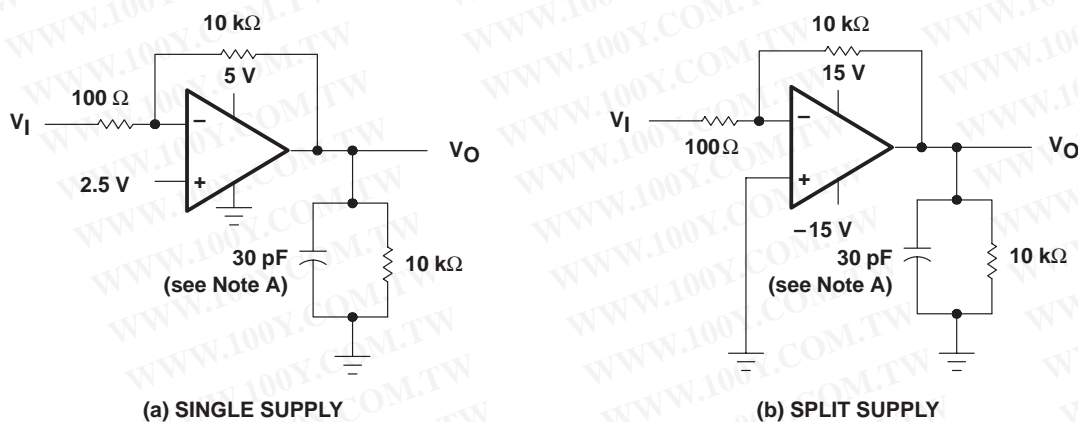

Figure 2. Noise-Voltage Test Circuit



NOTE A:  $C_L$  includes fixture capacitance.

Figure 3. Unity-Gain Bandwidth and Phase-Margin Test Circuit

PARAMETER MEASUREMENT INFORMATION

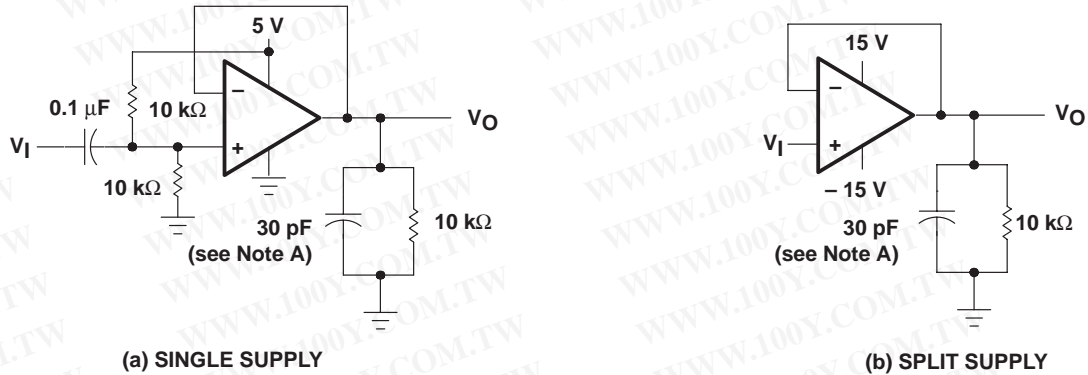

NOTE A:  $C_L$  includes fixture capacitance.

Figure 4. Small-Signal Pulse-Response Test Circuit

typical values

Typical values presented in this data sheet represent the median (50% point) of device parametric performance.

勝特力材料 886-3-5753170  
 勝特力电子(上海) 86-21-34970699  
 勝特力电子(深圳) 86-755-83298787  
[Http://www.100y.com.tw](http://www.100y.com.tw)

**TLE202x, TLE202xA, TLE202xB, TLE202xY**  
**EXCALIBUR HIGH-SPEED LOW-POWER PRECISION**  
**OPERATIONAL AMPLIFIERS**

SLOS191 – FEBRUARY 1997

**TYPICAL CHARACTERISTICS**

**Table of Graphs**

|             |   |   | <b>FIGURE</b>              |
|-------------|---|---|----------------------------|
| $V_{IO}$    | Input offset voltage                            | Distribution  | 5, 6, 7                    |
| $I_{IB}$    | Input bias current                              | vs Common-mode input voltage<br>vs Free-air temperature             | 8, 9, 10<br>11, 12, 13     |
| $I_I$       | Input current                                   | vs Differential input voltage                                       | 14                         |
| $V_{OM}$    | Maximum peak output voltage                     | vs Output current<br>vs Free-air temperature                        | 15, 16, 17<br>18           |
| $V_{OH}$    | High-level output voltage                       | vs High-level output current<br>vs Free-air temperature             | 19, 20<br>21               |
| $V_{OL}$    | Low-level output voltage                        | vs Low-level output current<br>vs Free-air temperature              | 22<br>23                   |
| $V_{O(PP)}$ | Maximum peak-to-peak output voltage             | vs Frequency  | 24, 25                     |
| $A_{VD}$    | Large-signal differential voltage amplification | vs Frequency<br>vs Free-air temperature                             | 26<br>27, 28, 29           |
| $I_{OS}$    | Short-circuit output current                    | vs Supply voltage<br>vs Free-air temperature                        | 30 – 33<br>34 – 37         |
| $I_{CC}$    | Supply current                                  | vs Supply voltage<br>vs Free-air temperature                        | 38, 39, 40<br>41, 42, 43   |
| $CMRR$      | Common-mode rejection ratio                     | vs Frequency  | 44, 45, 46                 |
| $SR$        | Slew rate                                       | vs Free-air temperature   | 47, 48, 49                 |
|             | Voltage-follower small-signal pulse response    | vs Time   | 50, 51                     |
|             | Voltage-follower large-signal pulse response    | vs Time   | 52 – 57                    |
| $V_{N(PP)}$ | Peak-to-peak equivalent input noise voltage     | 0.1 to 1 Hz<br>0.1 to 10 Hz   | 58<br>59                   |
| $V_n$       | Equivalent input noise voltage                  | vs Frequency  | 60                         |
| $B_1$       | Unity-gain bandwidth                            | vs Supply voltage<br>vs Free-air temperature                        | 61, 62<br>63, 64           |
| $\phi_m$    | Phase margin                                    | vs Supply voltage<br>vs Load capacitance<br>vs Free-air temperature | 65, 66<br>67, 68<br>69, 70 |
|             | Phase shift                                     | vs Frequency  | 26                         |

勝特力材料 86-3-5753170  
 勝特力电子(上海) 86-21-34970699  
 勝特力电子(深圳) 86-755-83298787  
[Http://www.100y.com.tw](http://www.100y.com.tw)



TYPICAL CHARACTERISTICS

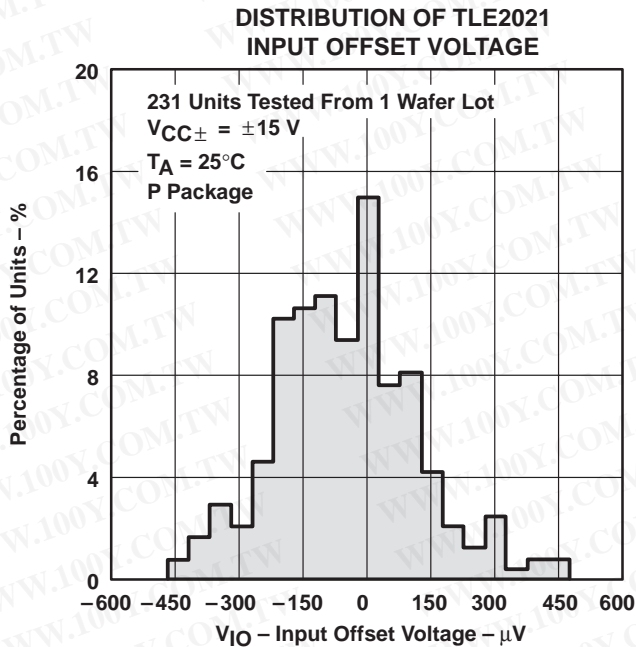

Figure 5

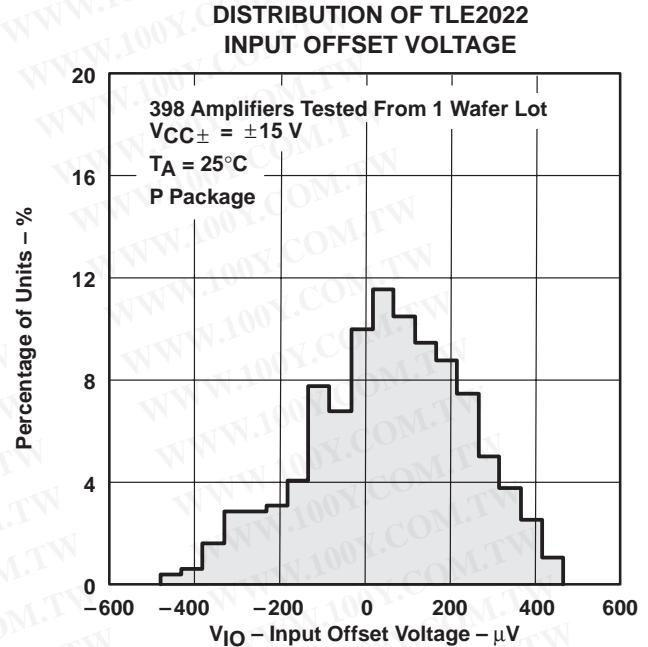

Figure 6

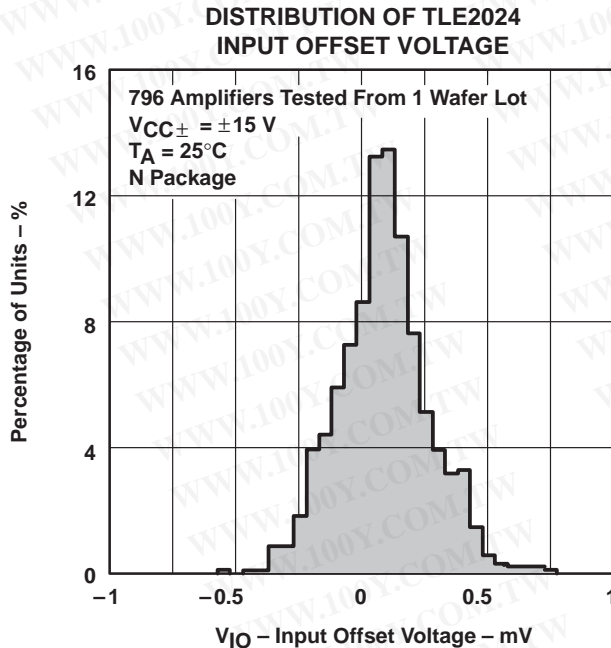

Figure 7

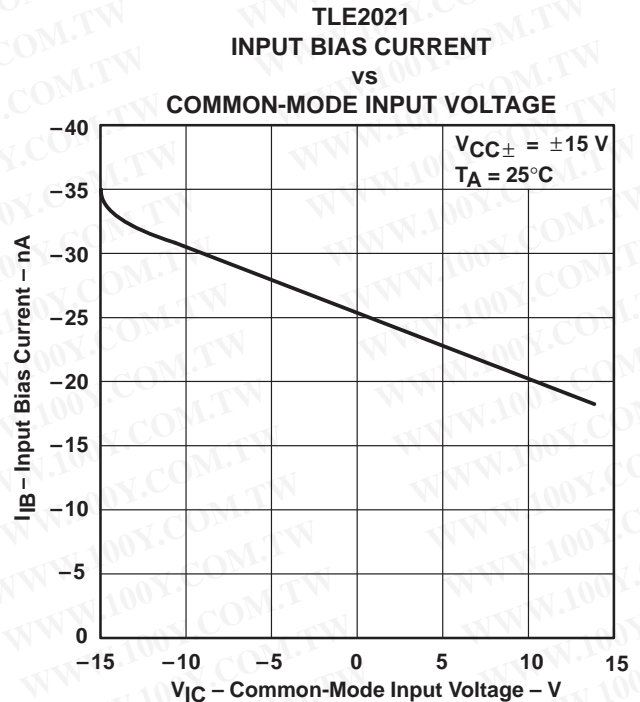

Figure 8

勝特力材料 886-3-5753170  
 勝特力电子(上海) 86-21-34970699  
 勝特力电子(深圳) 86-755-83298787  
[Http://www.100y.com.tw](http://www.100y.com.tw)

TYPICAL CHARACTERISTICS

TLE2022  
 INPUT BIAS CURRENT  
 vs  
 COMMON-MODE INPUT VOLTAGE

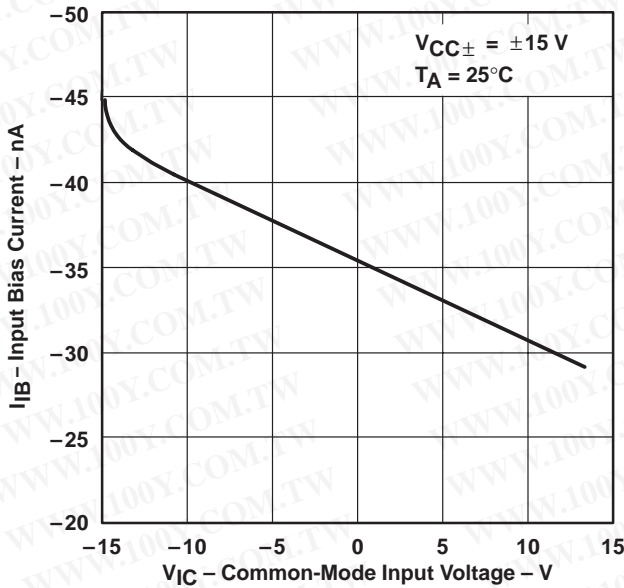

Figure 9

TLE2024  
 INPUT BIAS CURRENT  
 vs  
 COMMON-MODE INPUT VOLTAGE

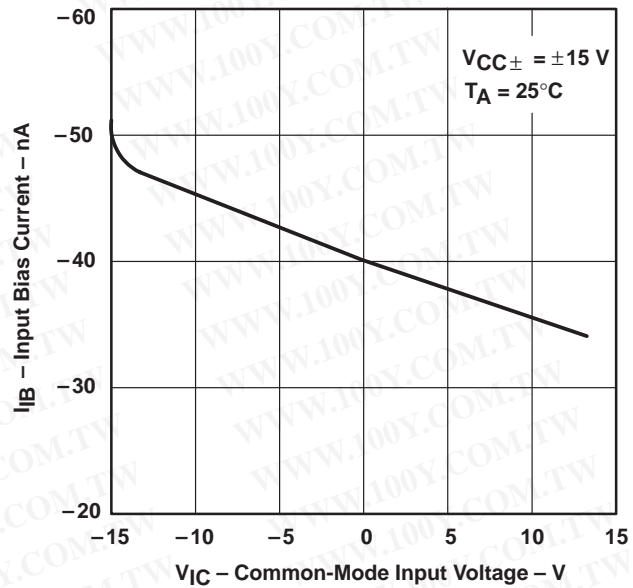

Figure 10

TLE2021  
 INPUT BIAS CURRENT†  
 vs  
 FREE-AIR TEMPERATURE

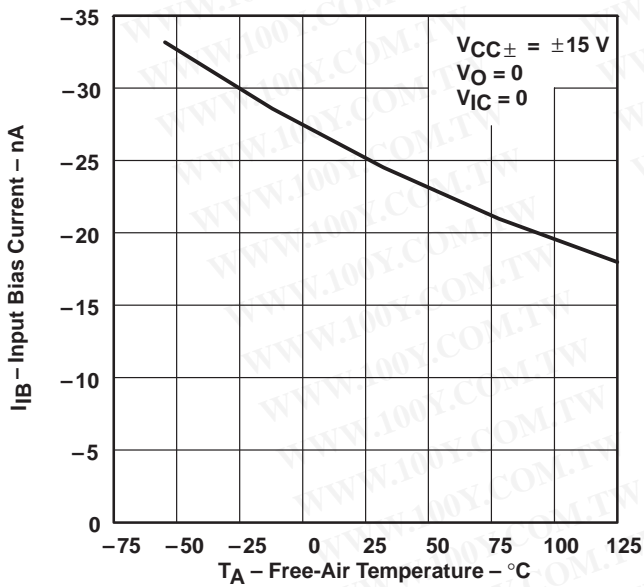

Figure 11

TLE2022  
 INPUT BIAS CURRENT†  
 vs  
 FREE-AIR TEMPERATURE

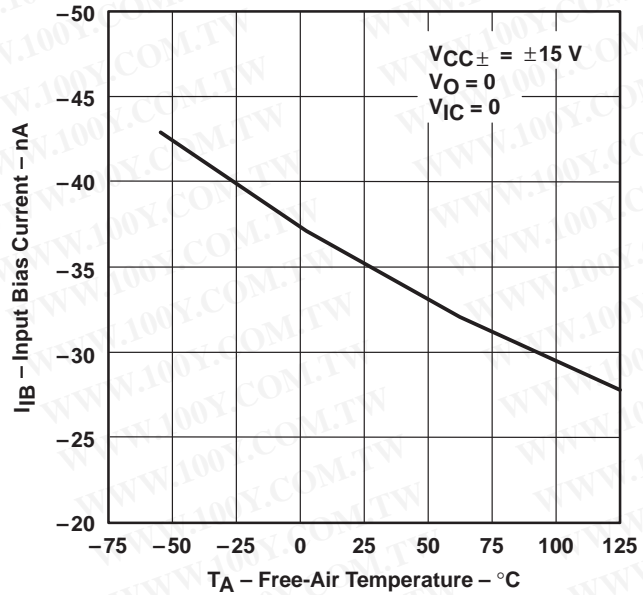

Figure 12

† Data at high and low temperatures are applicable only within the rated operating free-air temperature ranges of the various devices.

TYPICAL CHARACTERISTICS

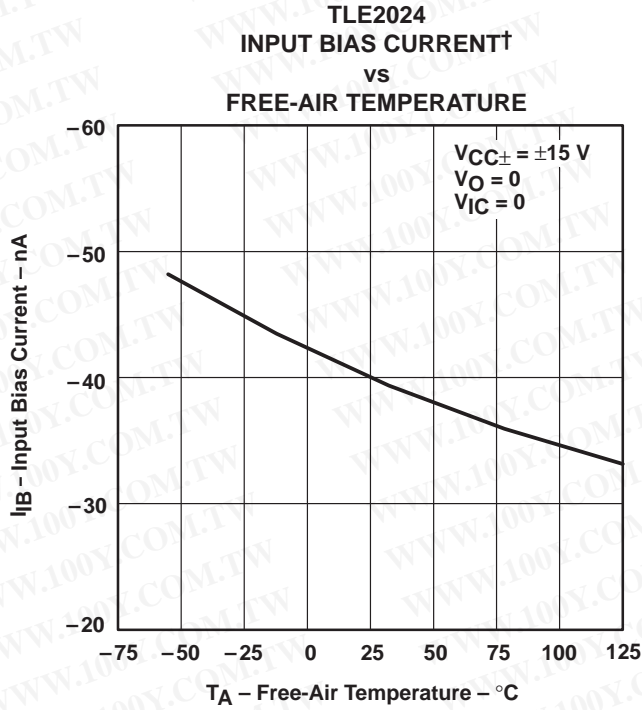

Figure 13

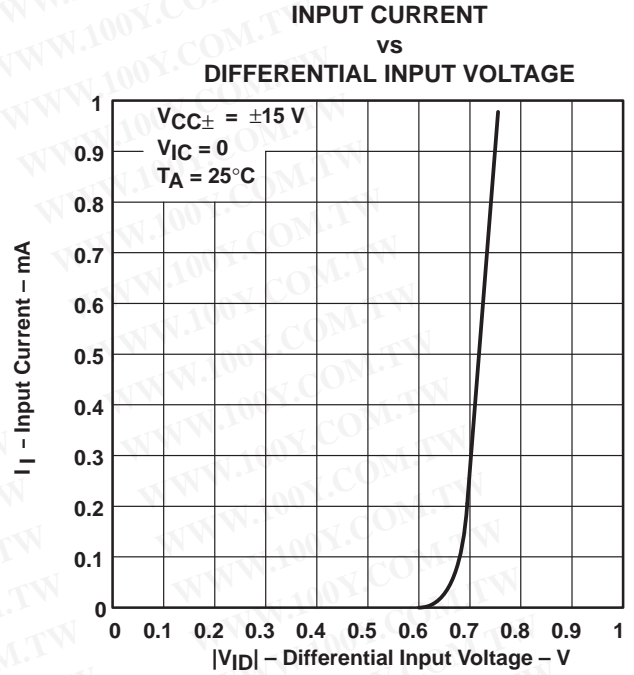

Figure 14

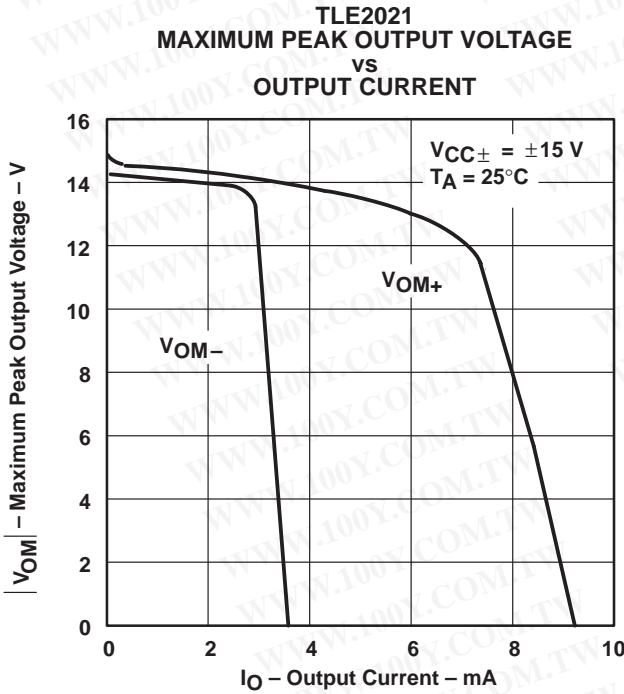

Figure 15

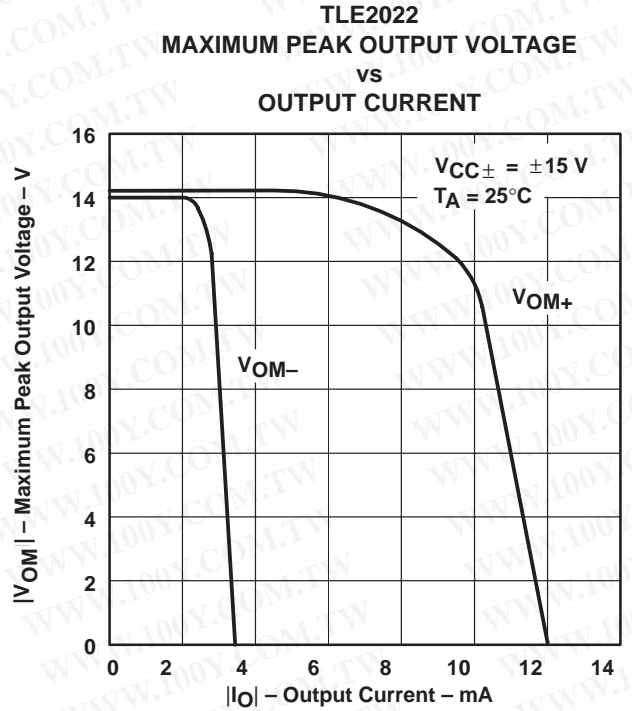
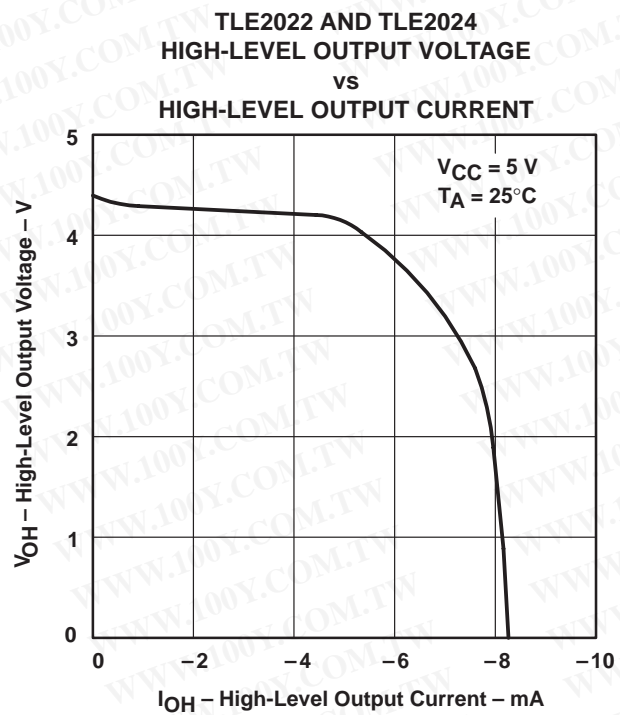
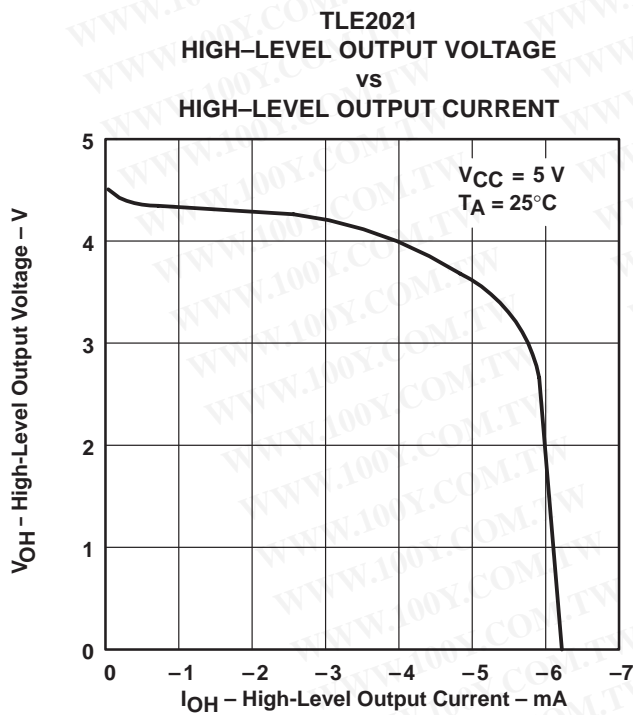
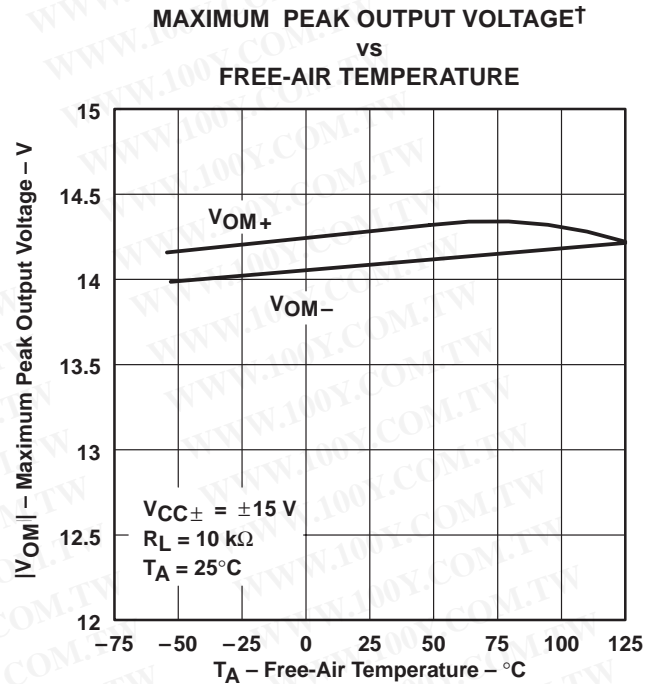
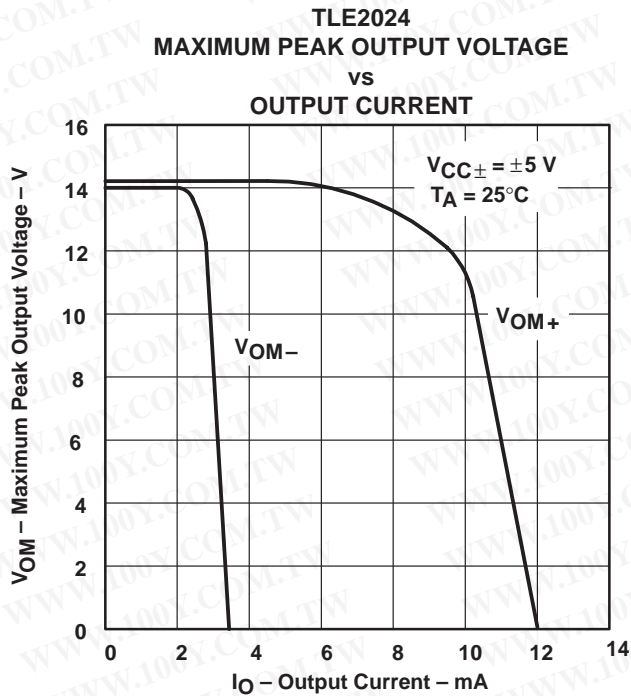

Figure 16

† Data at high and low temperatures are applicable only within the rated operating free-air temperature ranges of the various devices.

TYPICAL CHARACTERISTICS



† Data at high and low temperatures are applicable only within the rated operating free-air temperature ranges of the various devices.

TYPICAL CHARACTERISTICS

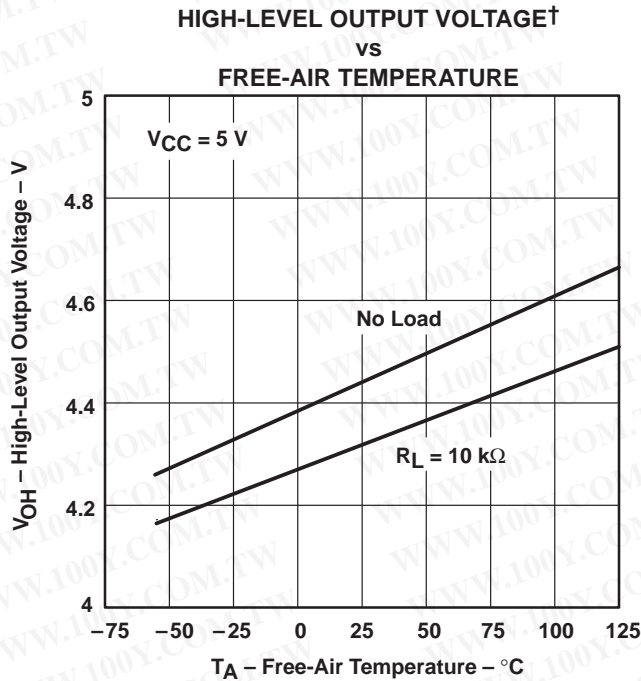

Figure 21

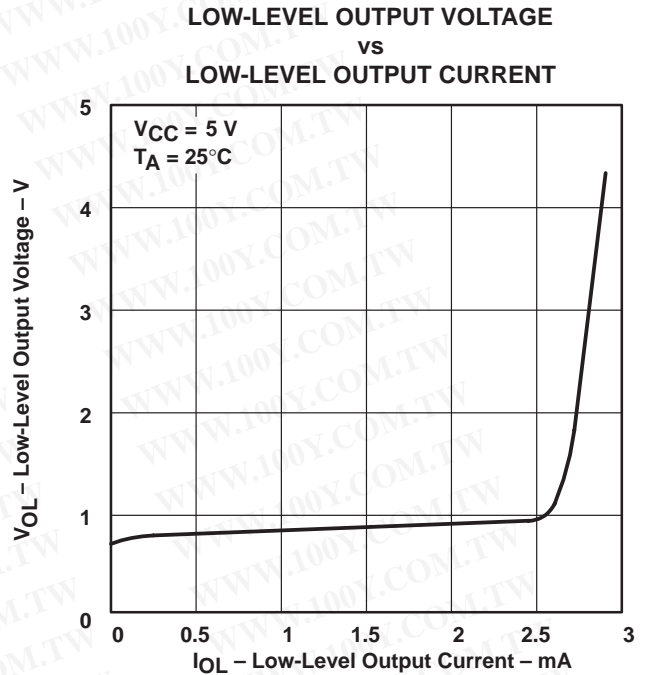

Figure 22

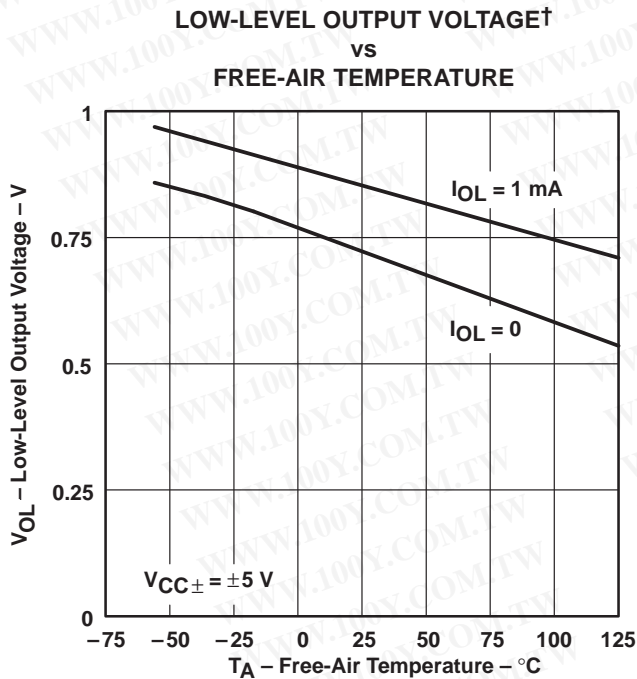

Figure 23

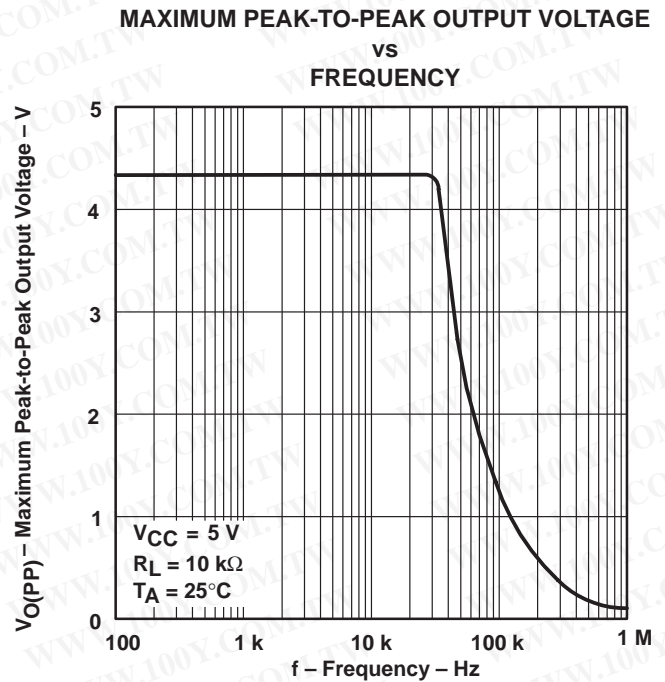

Figure 24

† Data at high and low temperatures are applicable only within the rated operating free-air temperature ranges of the various devices.

TYPICAL CHARACTERISTICS

MAXIMUM PEAK-TO-PEAK OUTPUT VOLTAGE  
 VS  
 FREQUENCY

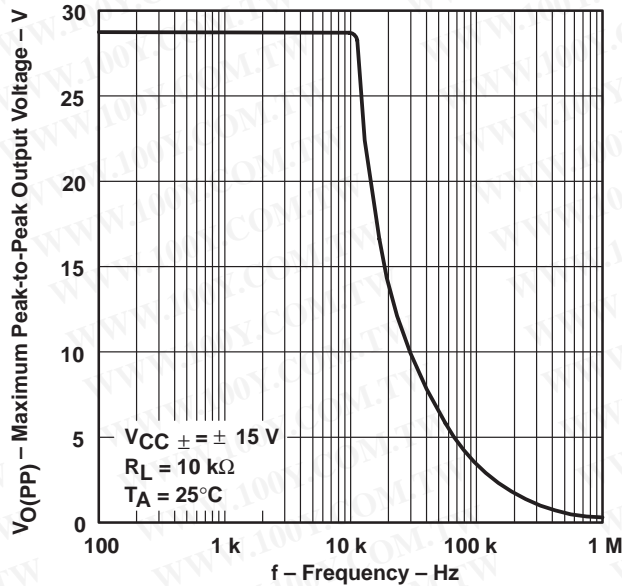

Figure 25

LARGE-SIGNAL DIFFERENTIAL VOLTAGE  
 AMPLIFICATION AND PHASE SHIFT  
 VS  
 FREQUENCY

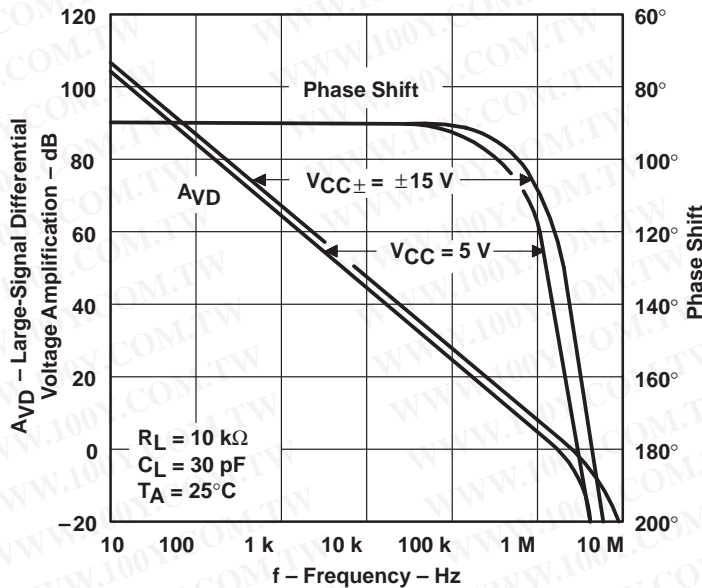

Figure 26

TYPICAL CHARACTERISTICS

TLE2021  
LARGE-SIGNAL DIFFERENTIAL VOLTAGE  
AMPLIFICATION†  
vs  
FREE-AIR TEMPERATURE

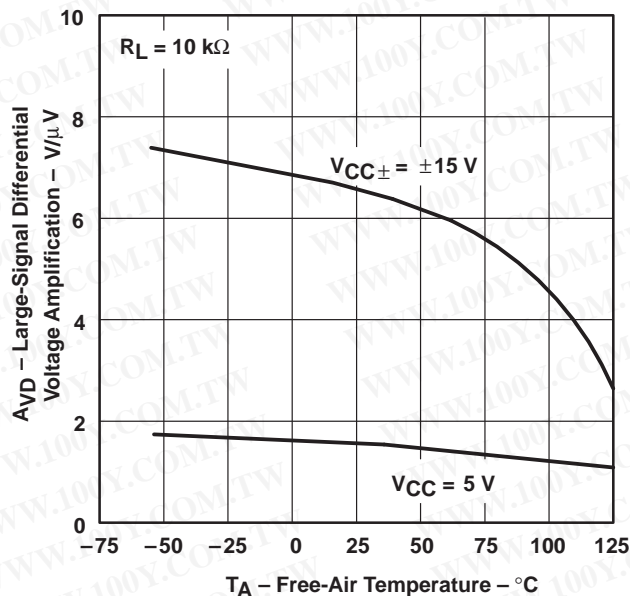

Figure 27

TLE2022  
LARGE-SIGNAL DIFFERENTIAL VOLTAGE  
AMPLIFICATION†  
vs  
FREE-AIR TEMPERATURE

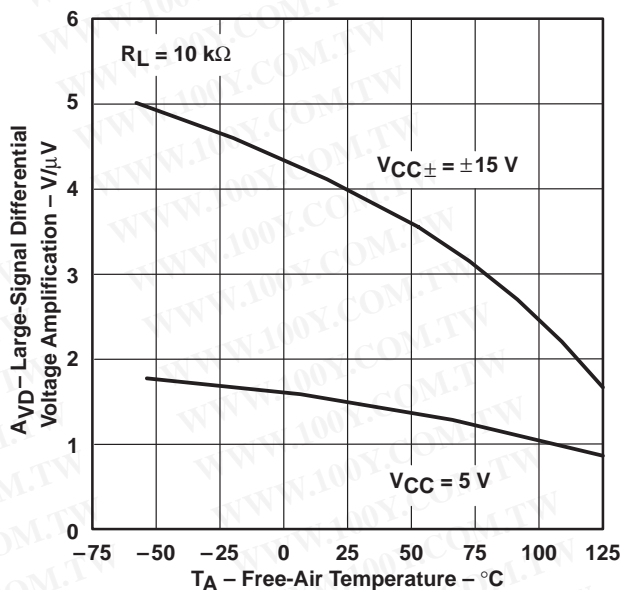

Figure 28

TLE2024  
LARGE-SIGNAL DIFFERENTIAL VOLTAGE  
AMPLIFICATION†  
vs  
FREE-AIR TEMPERATURE

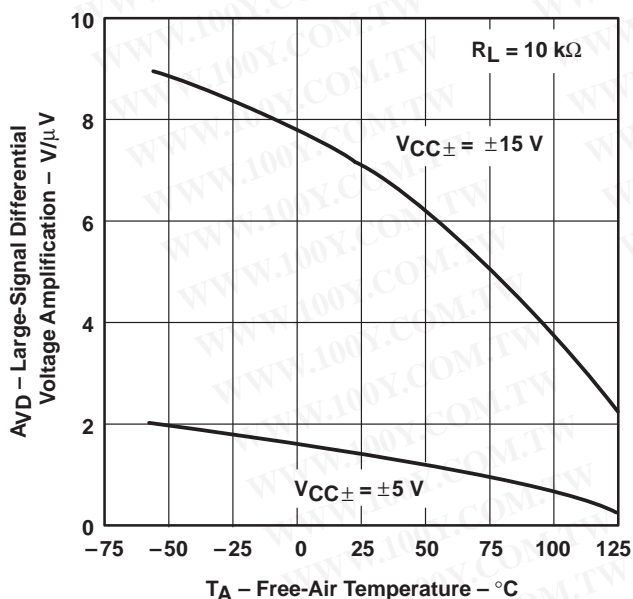

Figure 29

TLE2021  
SHORT-CIRCUIT OUTPUT CURRENT  
vs  
SUPPLY VOLTAGE

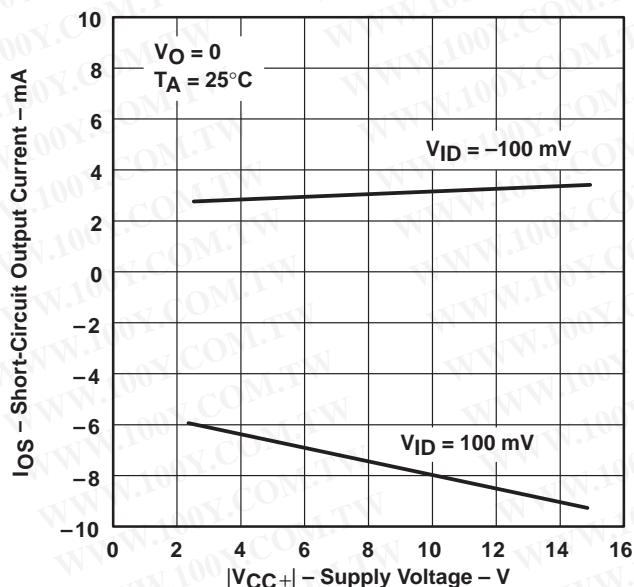

Figure 30

† Data at high and low temperatures are applicable only within the rated operating free-air temperature ranges of the various devices.

TYPICAL CHARACTERISTICS

TLE2022 AND TLE2024  
 SHORT-CIRCUIT OUTPUT CURRENT  
 vs  
 SUPPLY VOLTAGE

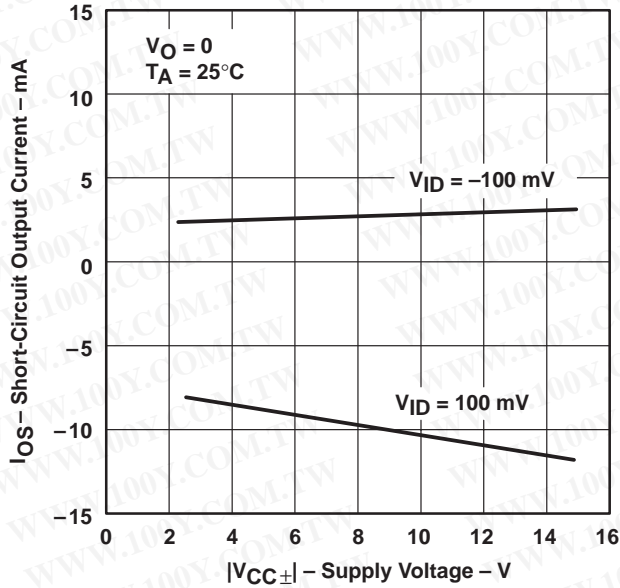

Figure 31

TLE2021  
 SHORT-CIRCUIT OUTPUT CURRENT  
 vs  
 SUPPLY VOLTAGE

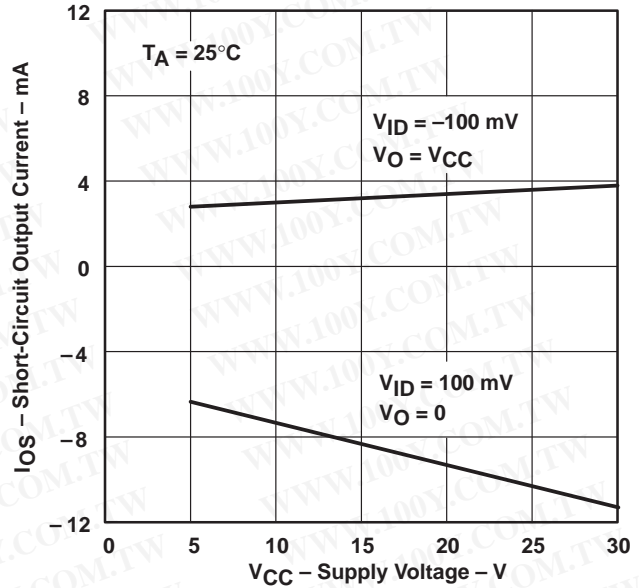

Figure 32

TLE2022 AND TLE2024  
 SHORT-CIRCUIT OUTPUT CURRENT  
 vs  
 SUPPLY VOLTAGE

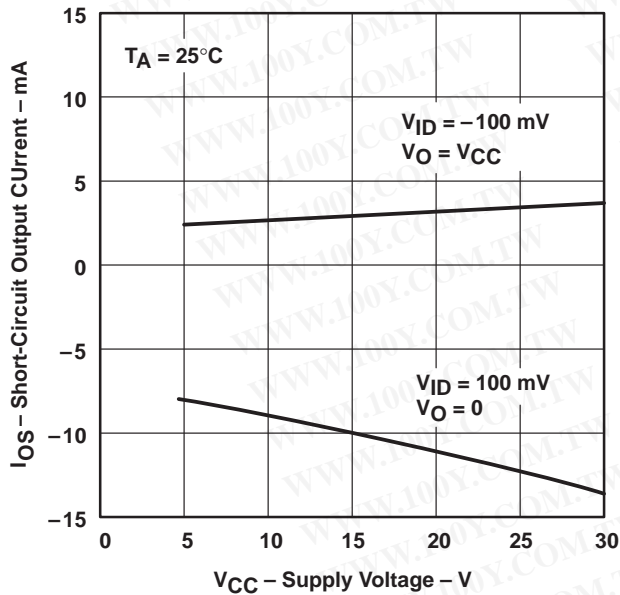

Figure 33

TLE2021  
 SHORT-CIRCUIT OUTPUT CURRENT†  
 vs  
 FREE-AIR TEMPERATURE

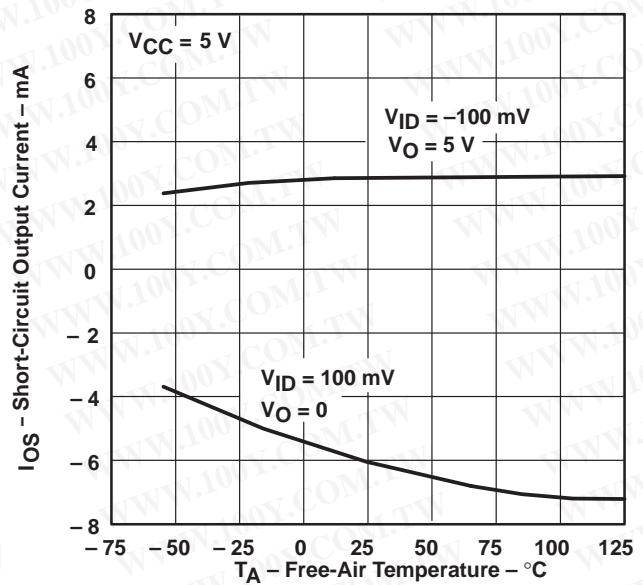

Figure 34

† Data at high and low temperatures are applicable only within the rated operating free-air temperature ranges of the various devices.

TYPICAL CHARACTERISTICS

TLE2022 AND TLE2024  
 SHORT-CIRCUIT OUTPUT CURRENT†  
 vs  
 FREE-AIR TEMPERATURE

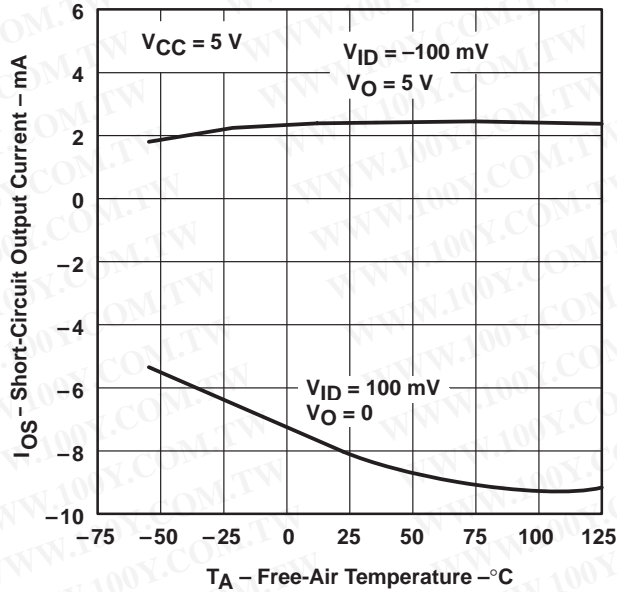

Figure 35

TLE2021  
 SHORT-CIRCUIT OUTPUT CURRENT†  
 vs  
 FREE-AIR TEMPERATURE

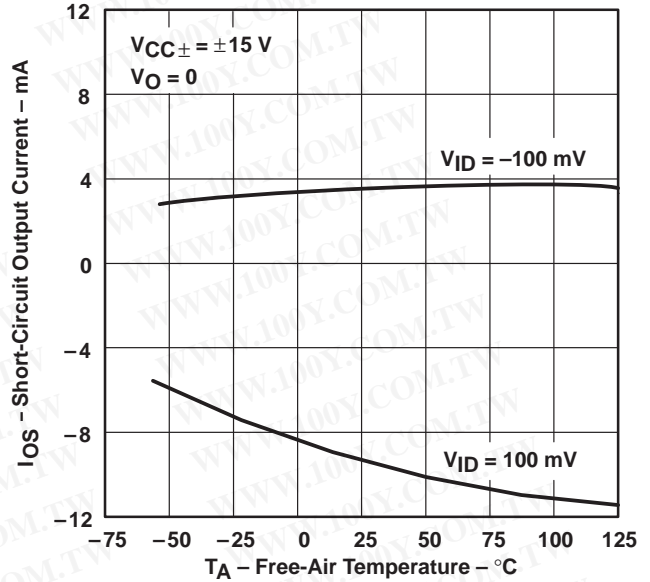

Figure 36

TLE2022 AND TLE2024  
 SHORT-CIRCUIT OUTPUT CURRENT†  
 vs  
 FREE-AIR TEMPERATURE

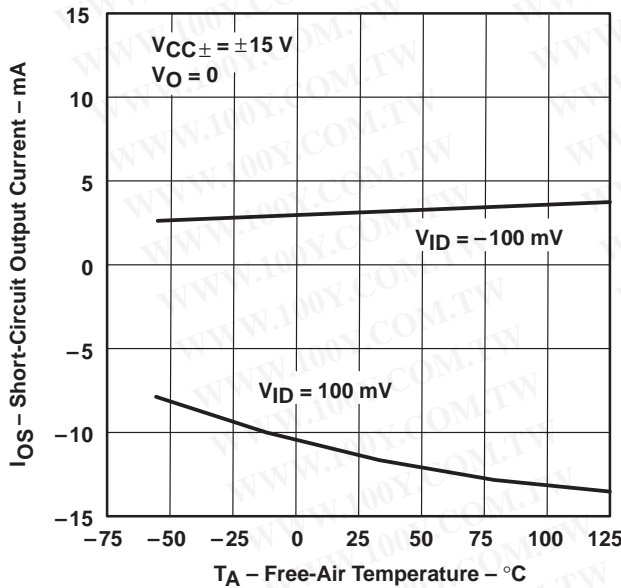

Figure 37

TLE2021  
 SUPPLY CURRENT  
 vs  
 SUPPLY VOLTAGE

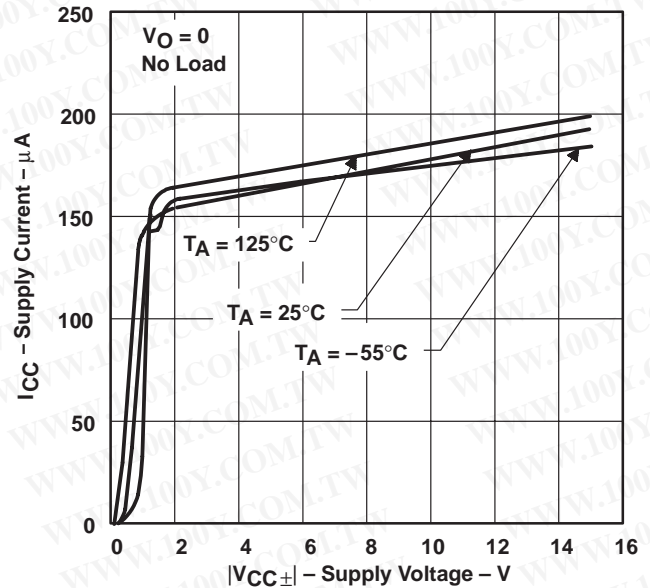

Figure 38

† Data at high and low temperatures are applicable only within the rated operating free-air temperature ranges of the various devices.

勝特力材料 886-3-5753170  
 勝特力电子(上海) 86-21-34970699  
 勝特力电子(深圳) 86-755-83298787  
[Http://www.100y.com.tw](http://www.100y.com.tw)

TYPICAL CHARACTERISTICS

TLE2022  
 SUPPLY CURRENT  
 vs  
 SUPPLY VOLTAGE

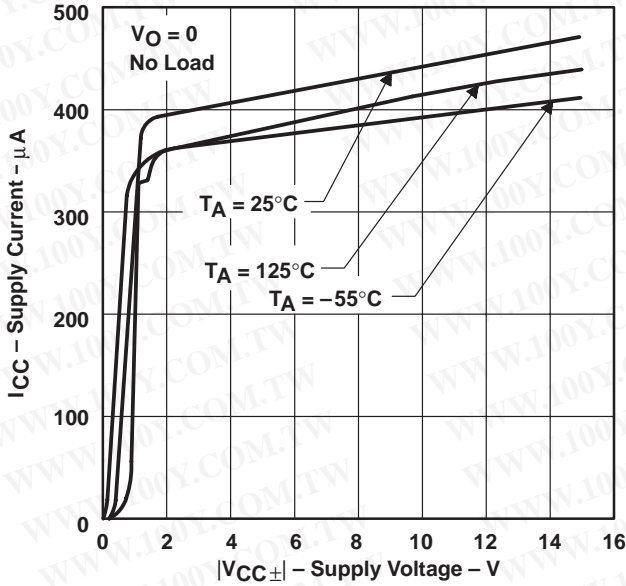

Figure 39

TLE2024  
 SUPPLY CURRENT  
 vs  
 SUPPLY VOLTAGE

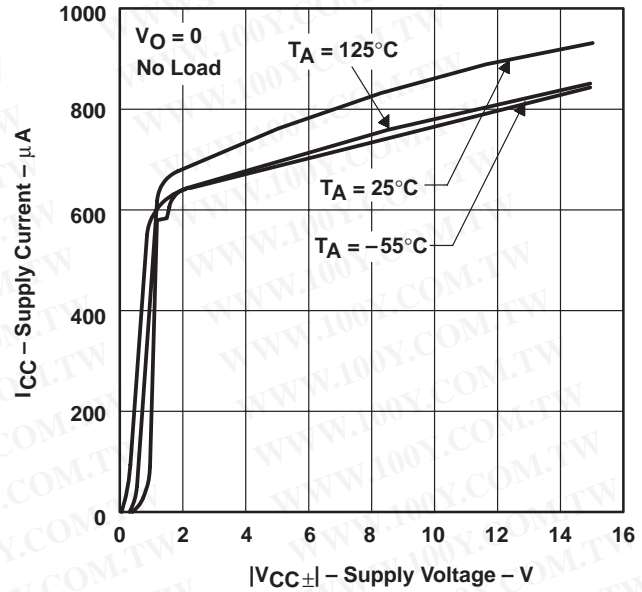

Figure 40

TLE2021  
 SUPPLY CURRENT†  
 vs  
 FREE-AIR TEMPERATURE

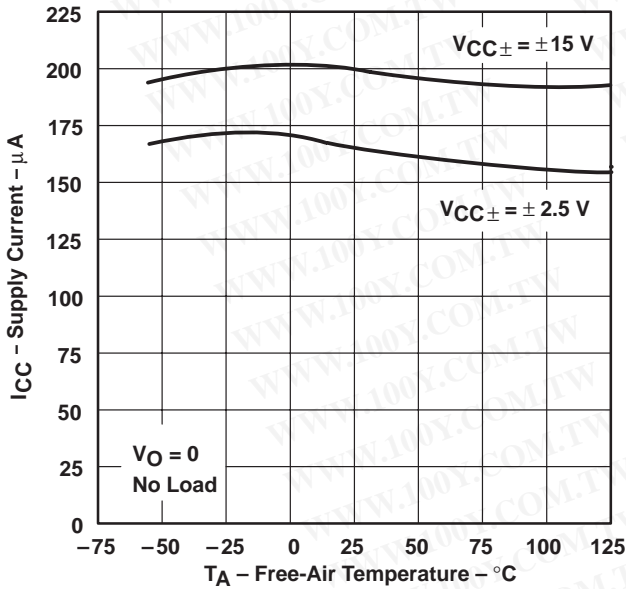

Figure 41

TLE2022  
 SUPPLY CURRENT†  
 vs  
 FREE-AIR TEMPERATURE

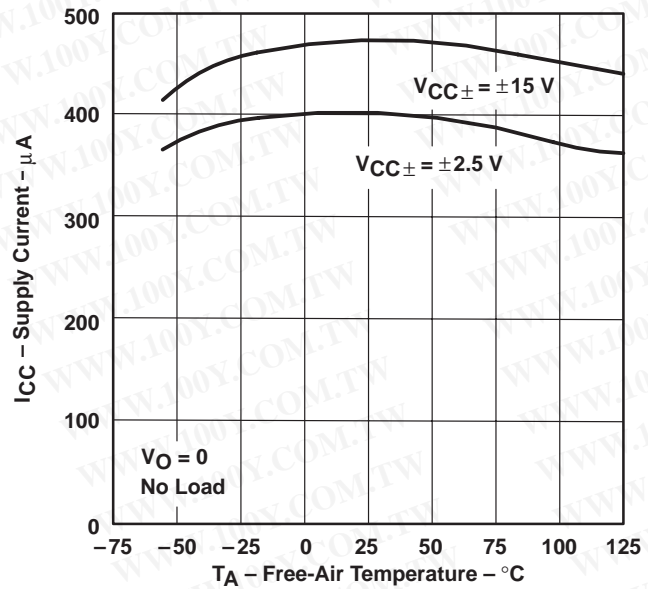
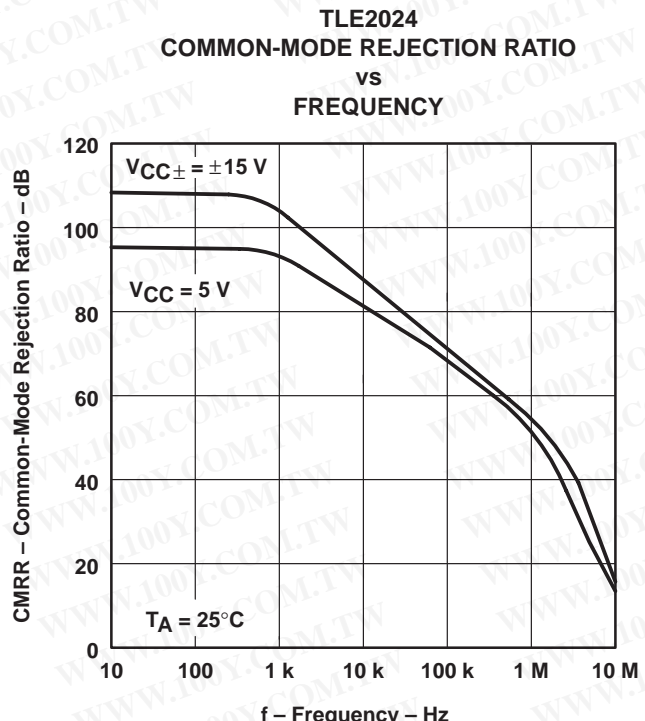
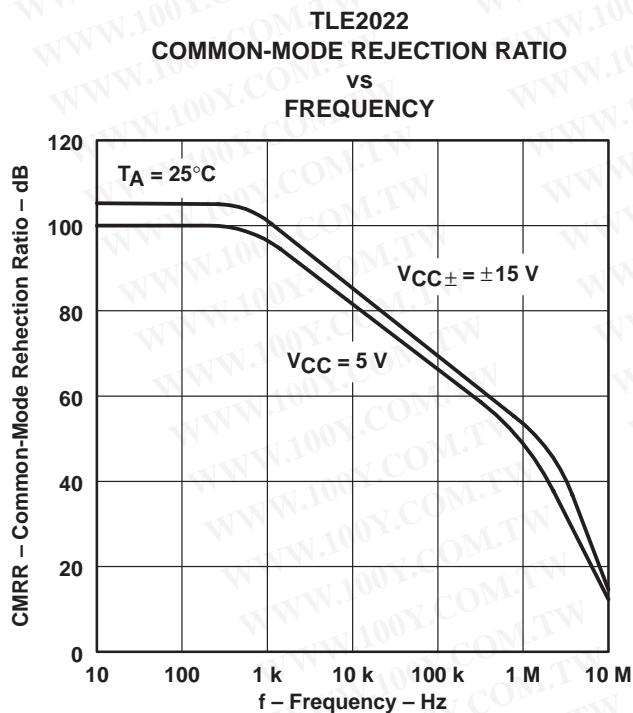
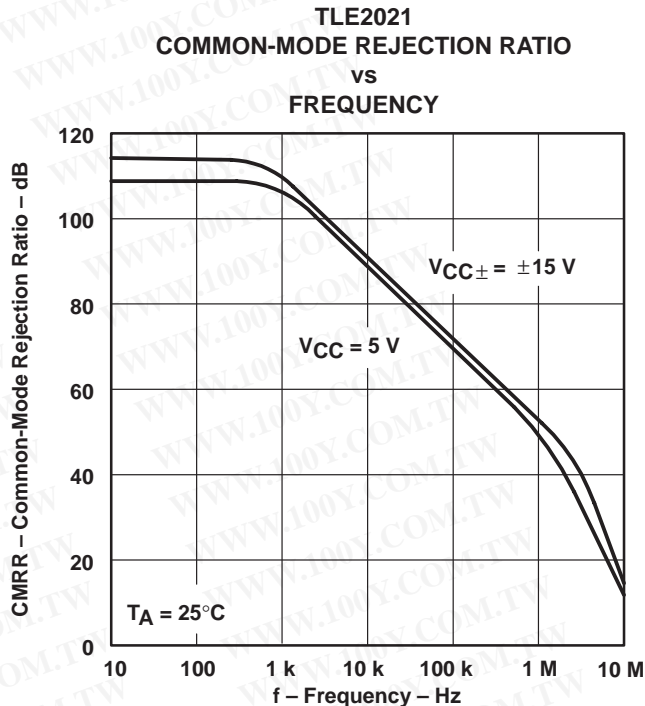
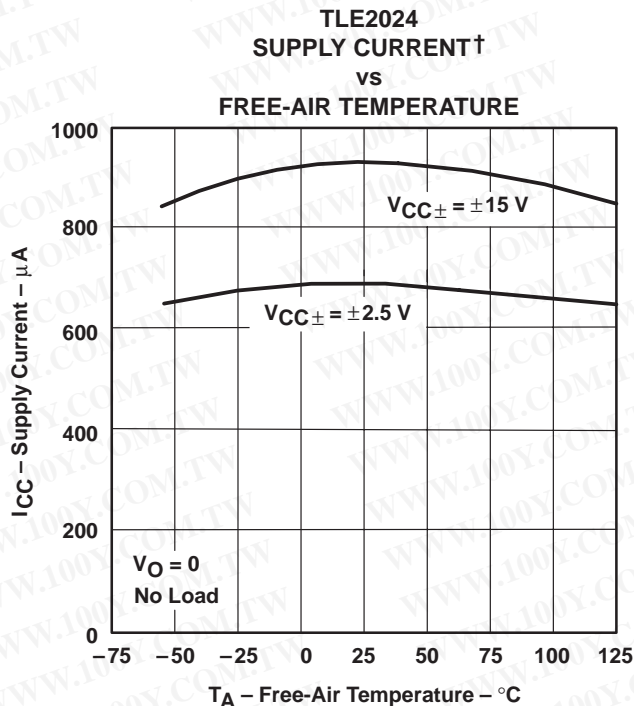

Figure 42

† Data at high and low temperatures are applicable only within the rated operating free-air temperature ranges of the various devices.

TYPICAL CHARACTERISTICS



† Data at high and low temperatures are applicable only within the rated operating free-air temperature ranges of the various devices.

TYPICAL CHARACTERISTICS

TLE2021  
 SLEW RATE†  
 vs  
 FREE-AIR TEMPERATURE

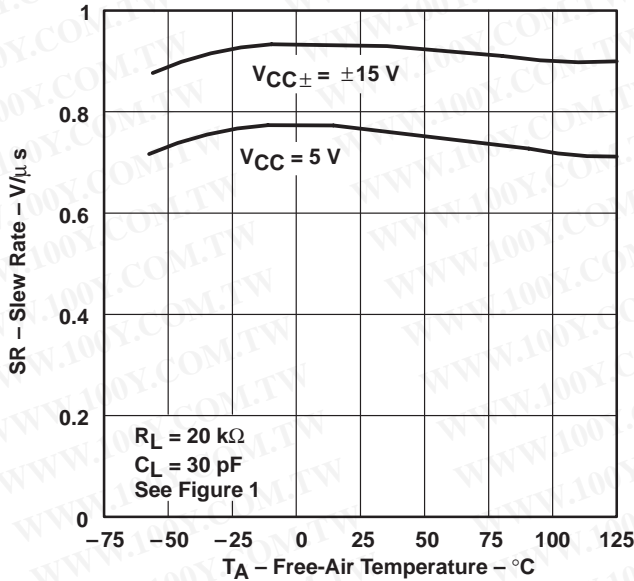

Figure 47

TLE2022  
 SLEW RATE†  
 vs  
 FREE-AIR TEMPERATURE

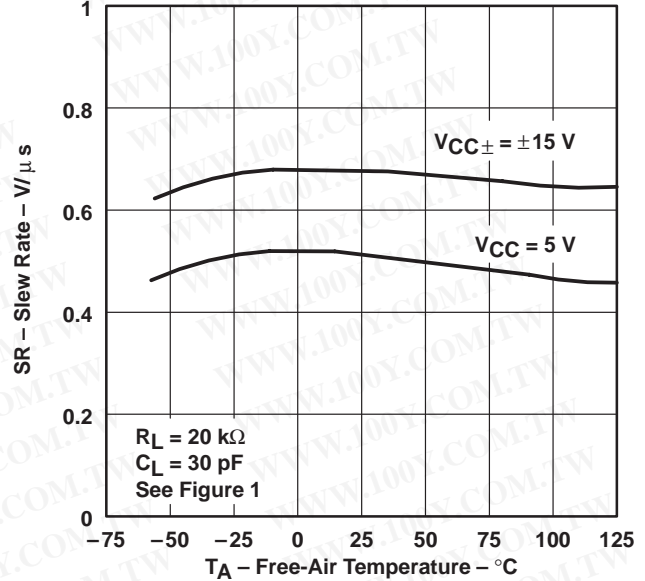

Figure 48

TLE2024  
 SLEW RATE†  
 vs  
 FREE-AIR TEMPERATURE

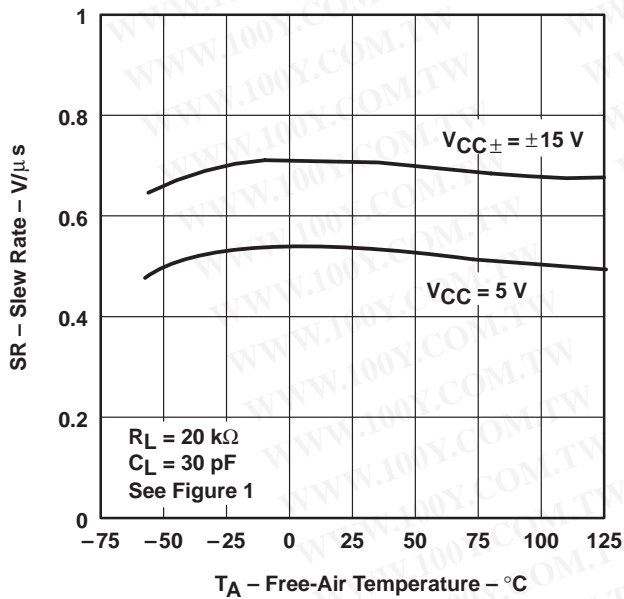

Figure 49

VOLTAGE-FOLLOWER  
 SMALL-SIGNAL  
 PULSE RESPONSE

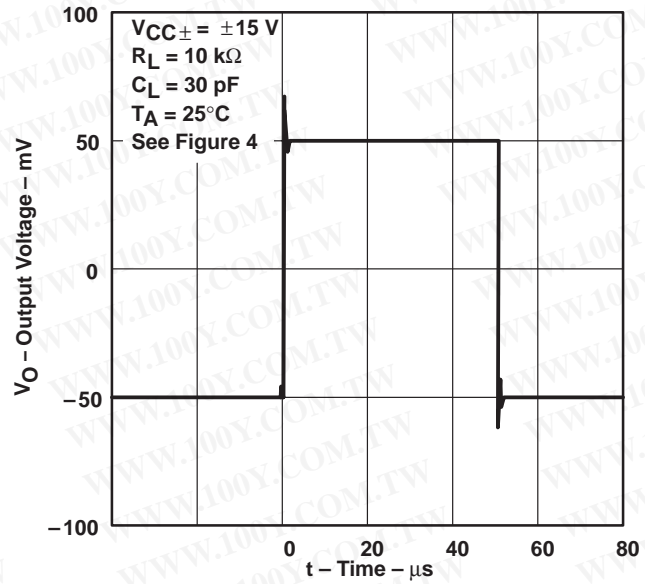

Figure 50

† Data at high and low temperatures are applicable only within the rated operating free-air temperature ranges of the various devices.

TYPICAL CHARACTERISTICS

VOLTAGE-FOLLOWER  
 SMALL-SIGNAL  
 PULSE RESPONSE

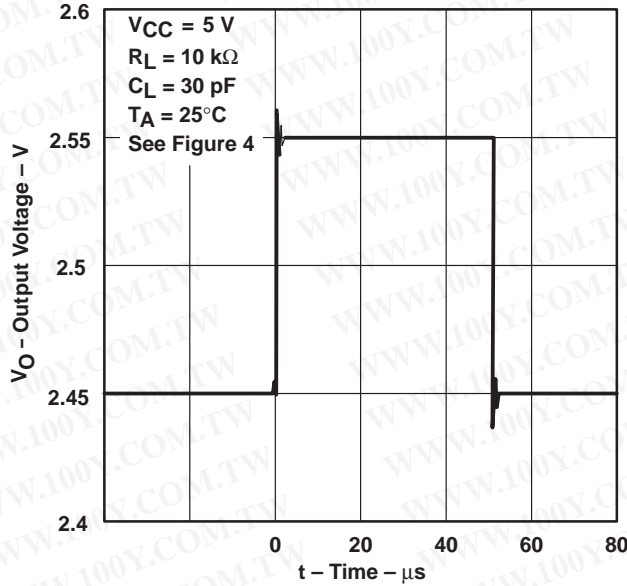

Figure 51

TLE2021  
 VOLTAGE-FOLLOWER LARGE-SIGNAL  
 PULSE RESPONSE

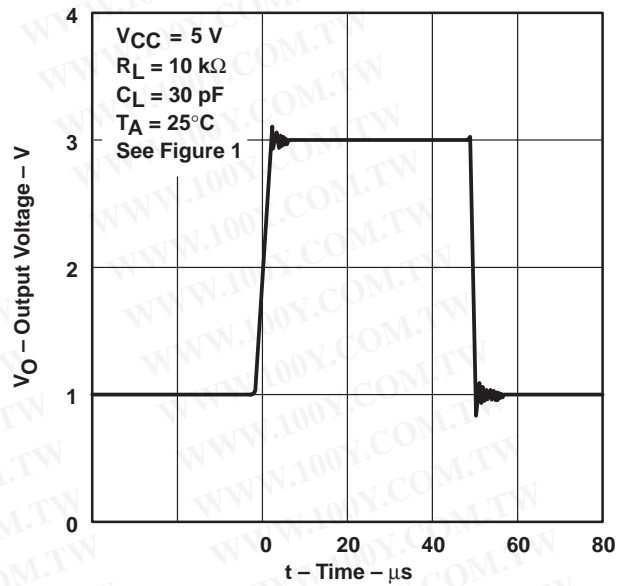

Figure 52

TLE2022  
 VOLTAGE-FOLLOWER LARGE-SIGNAL  
 PULSE RESPONSE

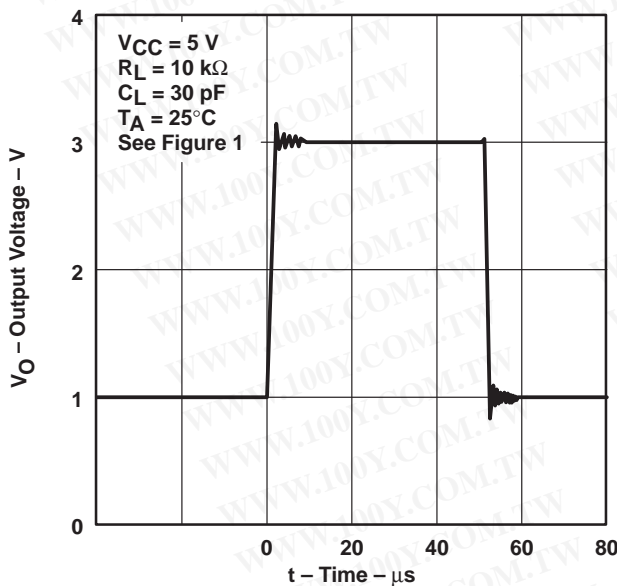

Figure 53

TLE2024  
 VOLTAGE-FOLLOWER LARGE-SCALE  
 PULSE RESPONSE

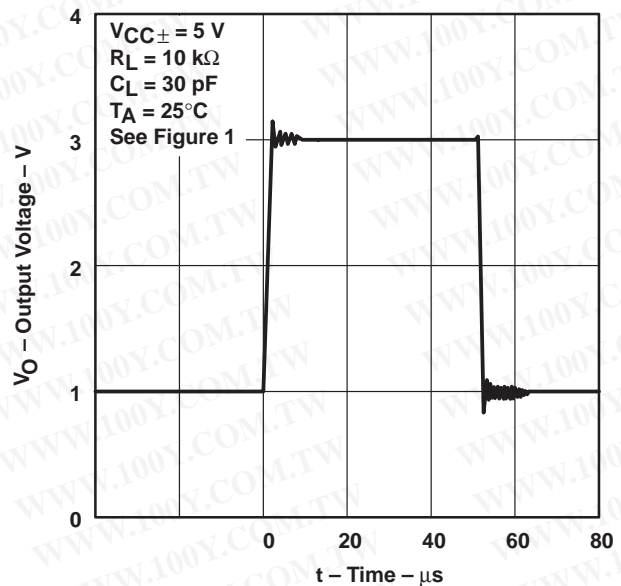

Figure 54

勝特力材料 886-3-5753170  
 勝特力电子(上海) 86-21-34970699  
 勝特力电子(深圳) 86-755-83298787  
[Http://www.100y.com.tw](http://www.100y.com.tw)

TLE202x, TLE202xA, TLE202xB, TLE202xY  
 EXCALIBUR HIGH-SPEED LOW-POWER PRECISION  
 OPERATIONAL AMPLIFIERS

SLOS191 – FEBRUARY 1997

TYPICAL CHARACTERISTICS

TLE2021  
 VOLTAGE-FOLLOWER LARGE-SIGNAL  
 PULSE RESPONSE

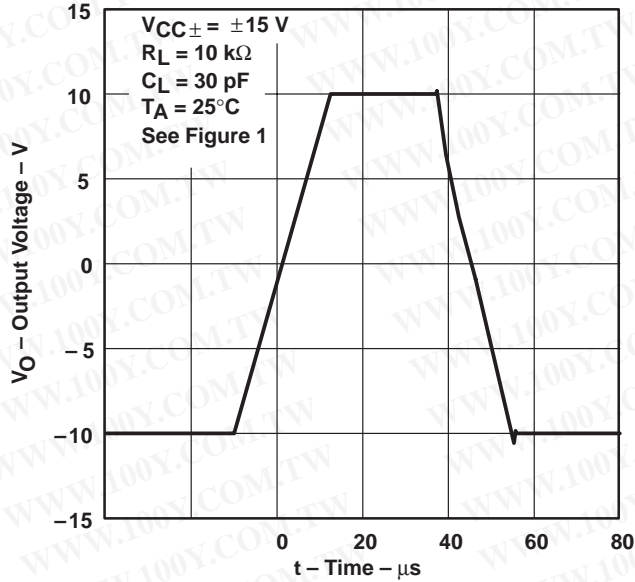

Figure 55

TLE2022  
 VOLTAGE-FOLLOWER LARGE-SIGNAL  
 PULSE RESPONSE

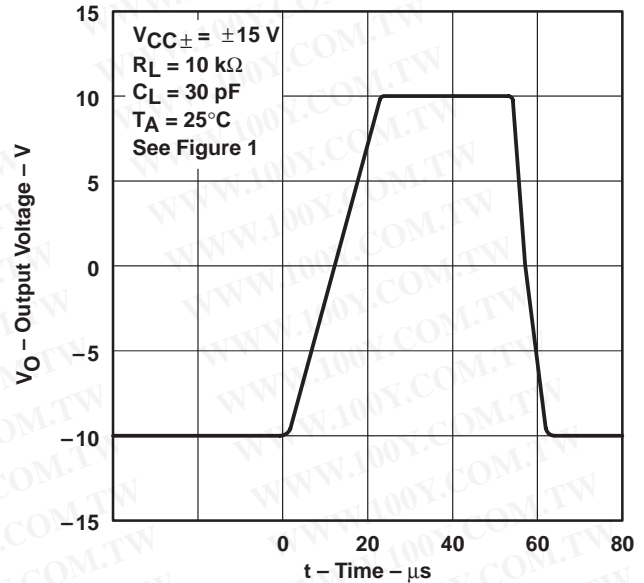

Figure 56

TLE2024  
 VOLTAGE-FOLLOWER LARGE-SIGNAL  
 PULSE RESPONSE

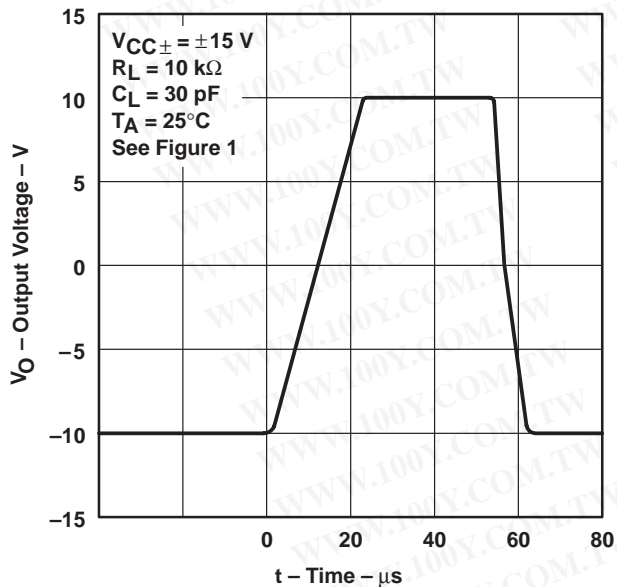

Figure 57

PEAK-TO-PEAK EQUIVALENT  
 INPUT NOISE VOLTAGE  
 0.1 TO 1 Hz

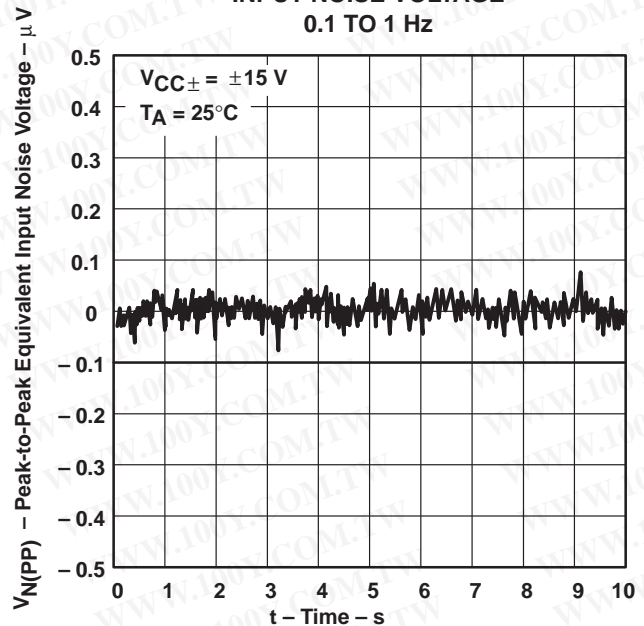

Figure 58

勝特力材料 886-3-5753170  
 勝特力电子(上海) 86-21-34970699  
 勝特力电子(深圳) 86-755-83298787  
[Http://www.100y.com.tw](http://www.100y.com.tw)



TYPICAL CHARACTERISTICS

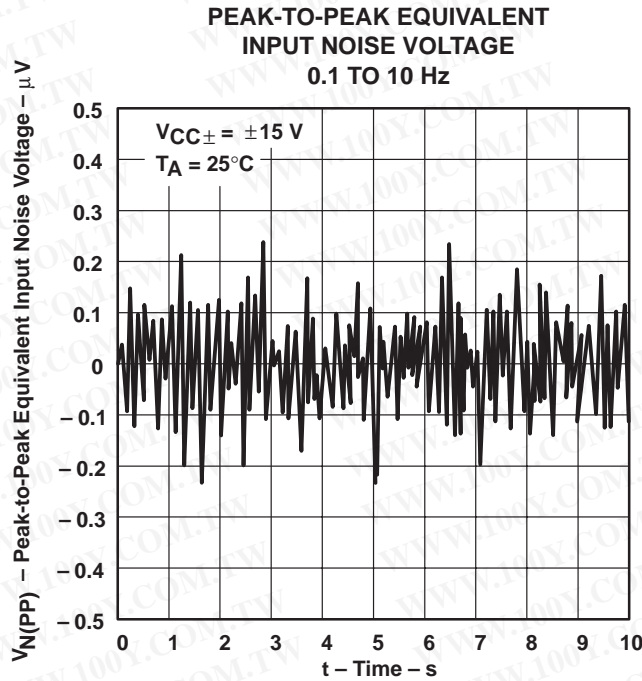

Figure 59

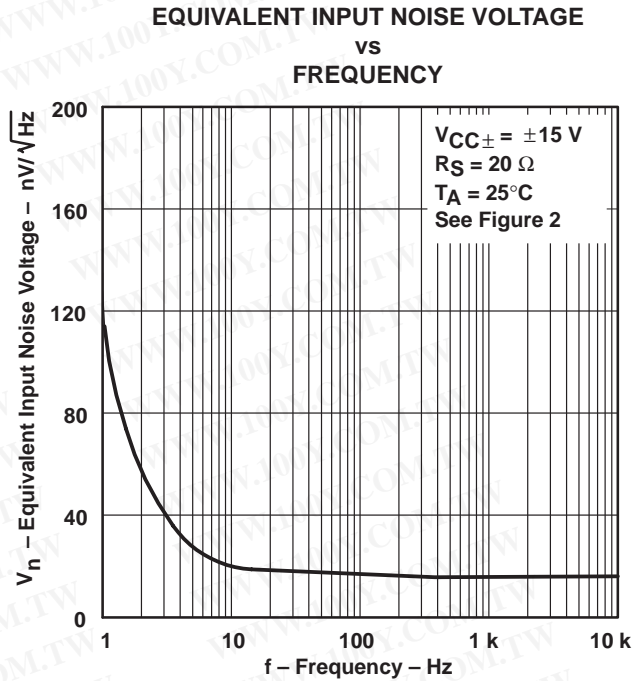

Figure 60

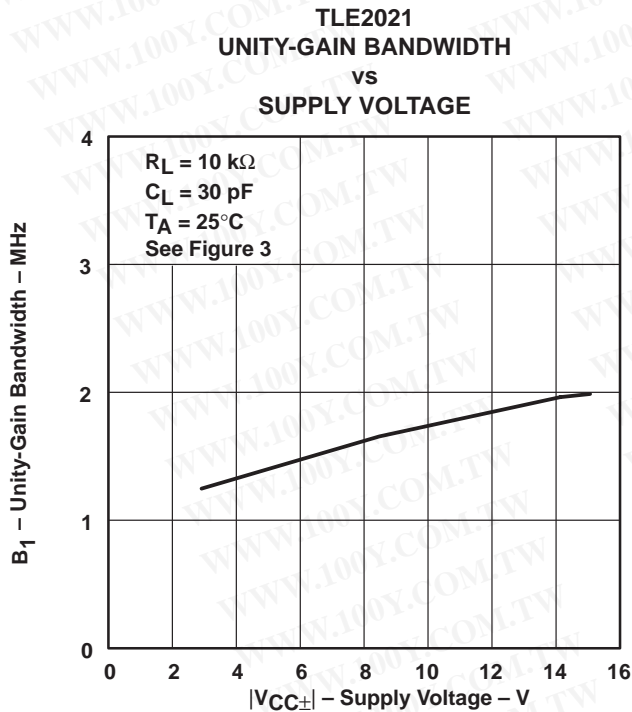

Figure 61

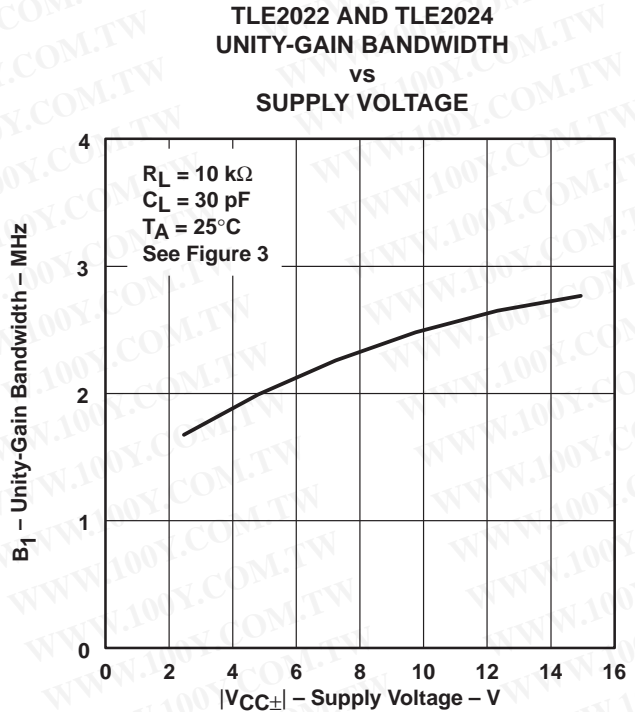

Figure 62

TYPICAL CHARACTERISTICS

TLE2021  
 UNITY-GAIN BANDWIDTH†  
 vs  
 FREE-AIR TEMPERATURE

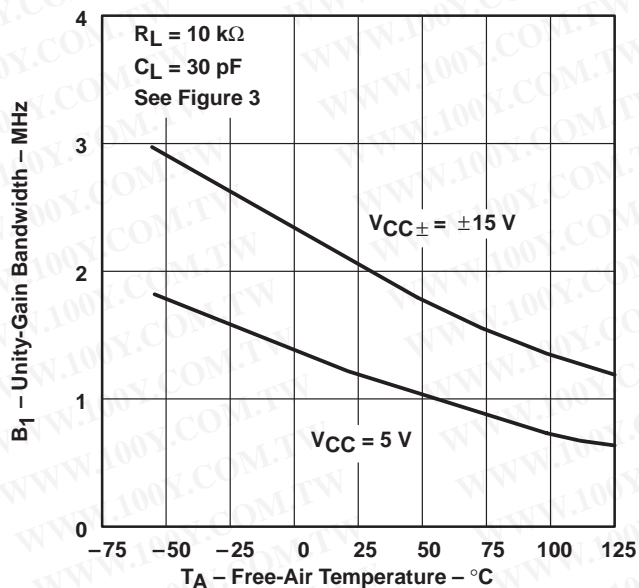

Figure 63

TLE2022 AND TLE2024  
 UNITY-GAIN BANDWIDTH†  
 vs  
 FREE-AIR TEMPERATURE

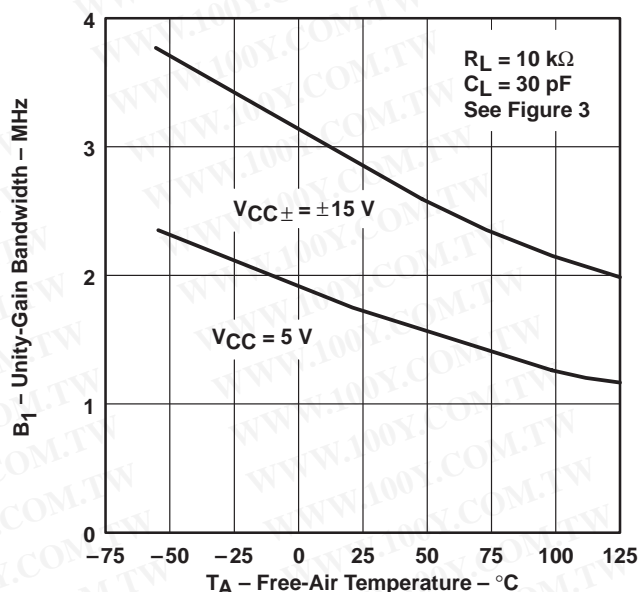

Figure 64

TLE2021  
 PHASE MARGIN  
 vs  
 SUPPLY VOLTAGE

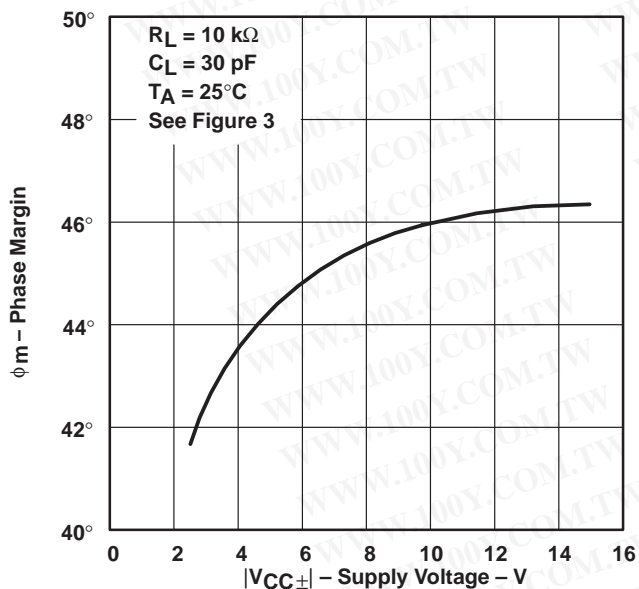

Figure 65

TLE2022 AND TLE2024  
 PHASE MARGIN  
 vs  
 SUPPLY VOLTAGE

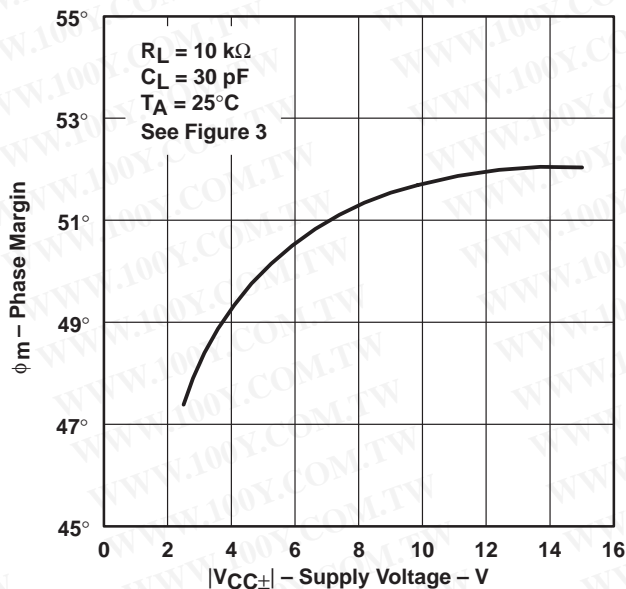
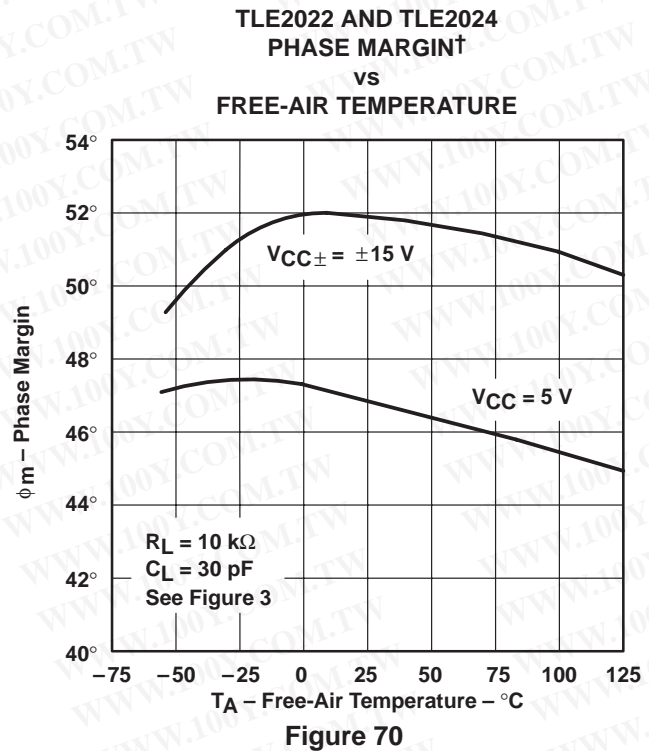
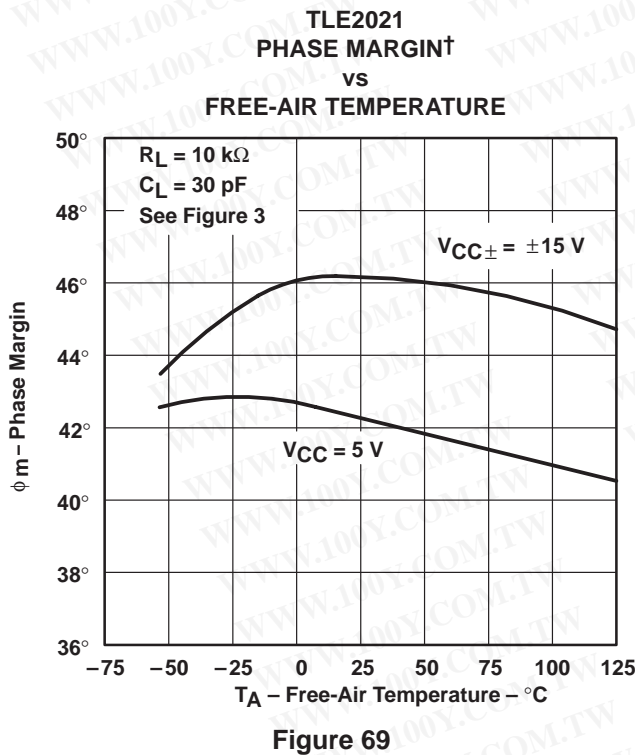
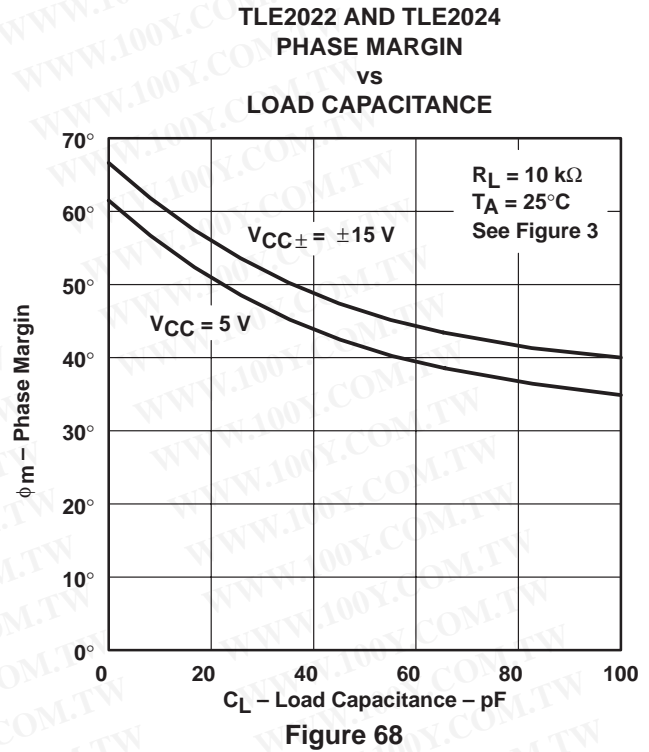
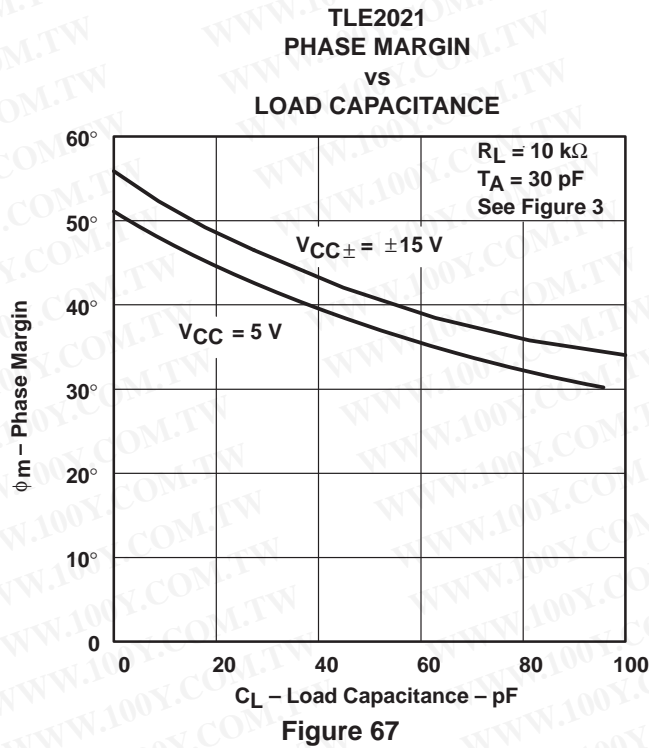

Figure 66

† Data at high and low temperatures are applicable only within the rated operating free-air temperature ranges of the various devices.

TYPICAL CHARACTERISTICS



† Data at high and low temperatures are applicable only within the rated operating free-air temperature ranges of the various devices.

## APPLICATION INFORMATION

### voltage-follower applications

The TLE202x circuitry includes input-protection diodes to limit the voltage across the input transistors; however, no provision is made in the circuit to limit the current if these diodes are forward biased. This condition can occur when the device is operated in the voltage-follower configuration and driven with a fast, large-signal pulse. It is recommended that a feedback resistor be used to limit the current to a maximum of 1 mA to prevent degradation of the device. This feedback resistor forms a pole with the input capacitance of the device. For feedback resistor values greater than 10 k $\Omega$ , this pole degrades the amplifier phase margin. This problem can be alleviated by adding a capacitor (20 pF to 50 pF) in parallel with the feedback resistor (see Figure 71).

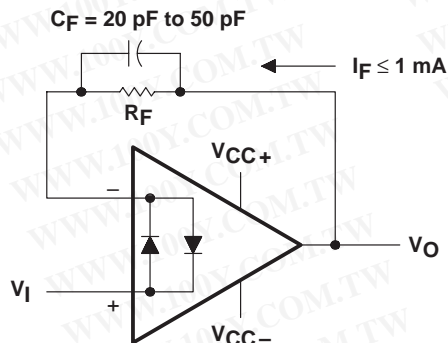

Figure 71. Voltage Follower

### Input offset voltage nulling

The TLE202x series offers external null pins that further reduce the input offset voltage. The circuit in Figure 72 can be connected as shown if this feature is desired. When external nulling is not needed, the null pins may be left disconnected.

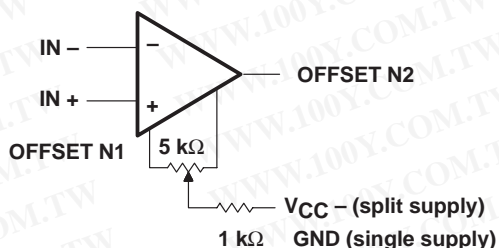

Figure 72. Input Offset Voltage Null Circuit

勝特力材料 886-3-5753170  
勝特力电子(上海) 86-21-34970699  
勝特力电子(深圳) 86-755-83298787  
[Http://www.100y.com.tw](http://www.100y.com.tw)

APPLICATION INFORMATION

macromodel information

Macromodel information provided was derived using Microsim *Parts*<sup>™</sup>, the model generation software used with Microsim *PSpice*<sup>™</sup>. The Boyle macromodel (see Note 5) and subcircuit in73, Figure 74, and Figure 75 were generated using the TLE202x typical electrical and operating characteristics at 25°C. Using this information, output simulations of the following key parameters can be generated to a tolerance of 20% (in most cases):

- Maximum positive output voltage swing
- Maximum negative output voltage swing
- Slew rate
- Quiescent power dissipation
- Input bias current
- Open-loop voltage amplification
- Unity-gain frequency
- Common-mode rejection ratio
- Phase margin
- DC output resistance
- AC output resistance
- Short-circuit output current limit

NOTE 5: G. R. Boyle, B. M. Cohn, D. O. Pederson, and J. E. Solomon, "Macromodeling of Integrated Circuit Operational Amplifiers", *IEEE Journal of Solid-State Circuits*, SC-9, 353 (1974).

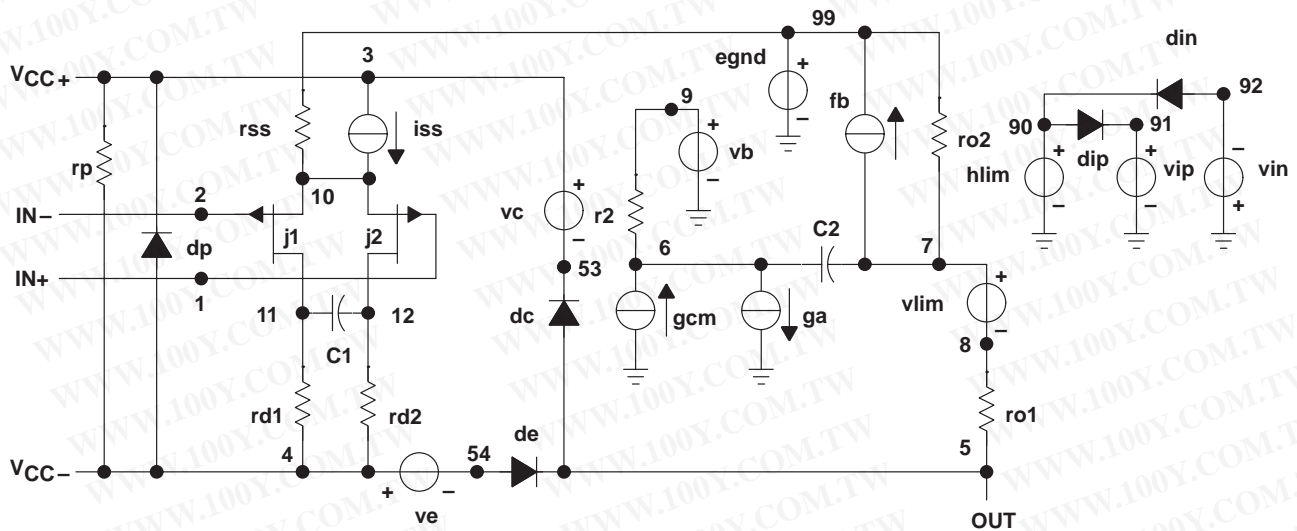

Figure 73. Boyle Subcircuit

勝特力材料 886-3-5753170  
勝特力电子(上海) 86-21-34970699  
勝特力电子(深圳) 86-755-83298787  
[Http://www.100y.com.tw](http://www.100y.com.tw)

*PSpice* and *Parts* are trademarks of MicroSim Corporation.

# TLE202x, TLE202xA, TLE202xB, TLE202xY EXCALIBUR HIGH-SPEED LOW-POWER PRECISION OPERATIONAL AMPLIFIERS

SLOS191 – FEBRUARY 1997

```
.SUBCKT TLE2021 1 2 3 4 5
*
c1 11 12 6.244E-12
c2 6 7 13.4E-12
c3 87 0 10.64E-9
cpsr 85 86 15.9E-9
dcm+ 81 82 dx
dcm- 83 81 dx
dc 5 53 dx
de 54 5 dx
dlp 90 91 dx
dln 92 90 dx
dp 4 3 dx
ecmr 84 99 (2 99) 1
egnd 99 0 poly(2) (3,0) (4,0) 0 .5 .5
epsr 85 0 poly(1) (3,4) -60E-6 2.0E-6
ense 89 2 poly(1) (88,0) 120E-6 1
fb 7 99 poly(6) vb vc ve vlp vln vpsr 0 547.3E6
+ -50E7 50E7 50E7 -50E7 547E6
ga 6 0 11 12 188.5E-6
gcm 0 6 10 99 335.2E-12
gpsr 85 86 (85,86) 100E-6
grc1 4 11 (4,11) 1.885E-4
grc2 4 12 (4,12) 1.885E-4
gre1 13 10 (13,10) 6.82E-4
gre2 14 10 (14,10) 6.82E-4
hlim 90 0 vlim 1k
hcmr 80 1 poly(2) vcm+ vcm- 0 1E2 1E2
irp 3 4 185E-6
iee 3 10 dc 15.67E-6
iio 2 0 2E-9
i1 88 0 1E-21
q1 11 89 13 qx
q2 12 80 14 qx
R2 6 9 100.0E3
rcm 84 81 1K
ree 10 99 14.76E6
rn1 87 0 2.55E8
rn2 87 88 11.67E3
ro1 8 5 62
ro2 7 99 63
vcm+ 82 99 13.3
vcm- 83 99 -14.6
vb 9 0 dc 0
vc 3 53 dc 1.300
ve 54 4 dc 1.500
vlim 7 8 dc 0
vlp 91 0 dc 3.600
vln 0 92 dc 3.600
vpsr 0 86 dc 0
.model dx d(is=800.0E-18)
.model qx pnp(is=800.0E-18 bf=270)
.ends
```

Figure 74. Boyle Macromodel for the TLE2021

```
.SUBCKT TLE2022 1 2 3 4 5
*
c1 11 12 6.814E-12
c2 6 7 20.00E-12
dc 5 53 dx
de 54 5 dx
dlp 90 91 dx
dln 92 90 dx
dp 4 3 dx
egnd 99 0 poly(2) (3,0) (4,0) 0 .5 .5
fb 7 99 poly(5) vb vc ve vlp vln 0
+ 45.47E6 -50E6 50E6 50E6 -50E6
ga 6 0 11 12 377.9E-6
gcm 0 6 10 99 7.84E-10
iee 3 10 DC 18.07E-6
hlim 90 0 vlim 1k
q1 11 2 13 qx
q2 12 1 14 qx
r2 6 9 100.0E3
rc1 4 11 2.842E3
rc2 4 12 2.842E3
ge1 13 10 (10,13) 31.299E-3
ge2 14 10 (10,14) 31.299E-3
ree 10 99 11.07E6
ro1 8 5 250
ro2 7 99 250
rp 3 4 137.2E3
vb 9 0 dc 0
vc 3 53 dc 1.300
ve 54 4 dc 1.500
vlim 7 8 dc 0
vlp 91 0 dc 3
vln 0 92 dc 3
.model dx d(is=800.0E-18)
.model qx pnp(is=800.0E-18 bf=257.1)
.ends
```

Figure 75. Boyle Macromodel for the TLE2022

勝特力材料 886-3-5753170  
 勝特力电子(上海) 86-21-34970699  
 勝特力电子(深圳) 86-755-83298787  
[Http://www.100y.com.tw](http://www.100y.com.tw)



TLE202x, TLE202xA, TLE202xB, TLE202xY  
 EXCALIBUR HIGH-SPEED LOW-POWER PRECISION  
 OPERATIONAL AMPLIFIERS

SLOS191 – FEBRUARY 1997

MECHANICAL INFORMATION

D (R-PDSO-G\*\*)

PLASTIC SMALL-OUTLINE PACKAGE

14 PIN SHOWN

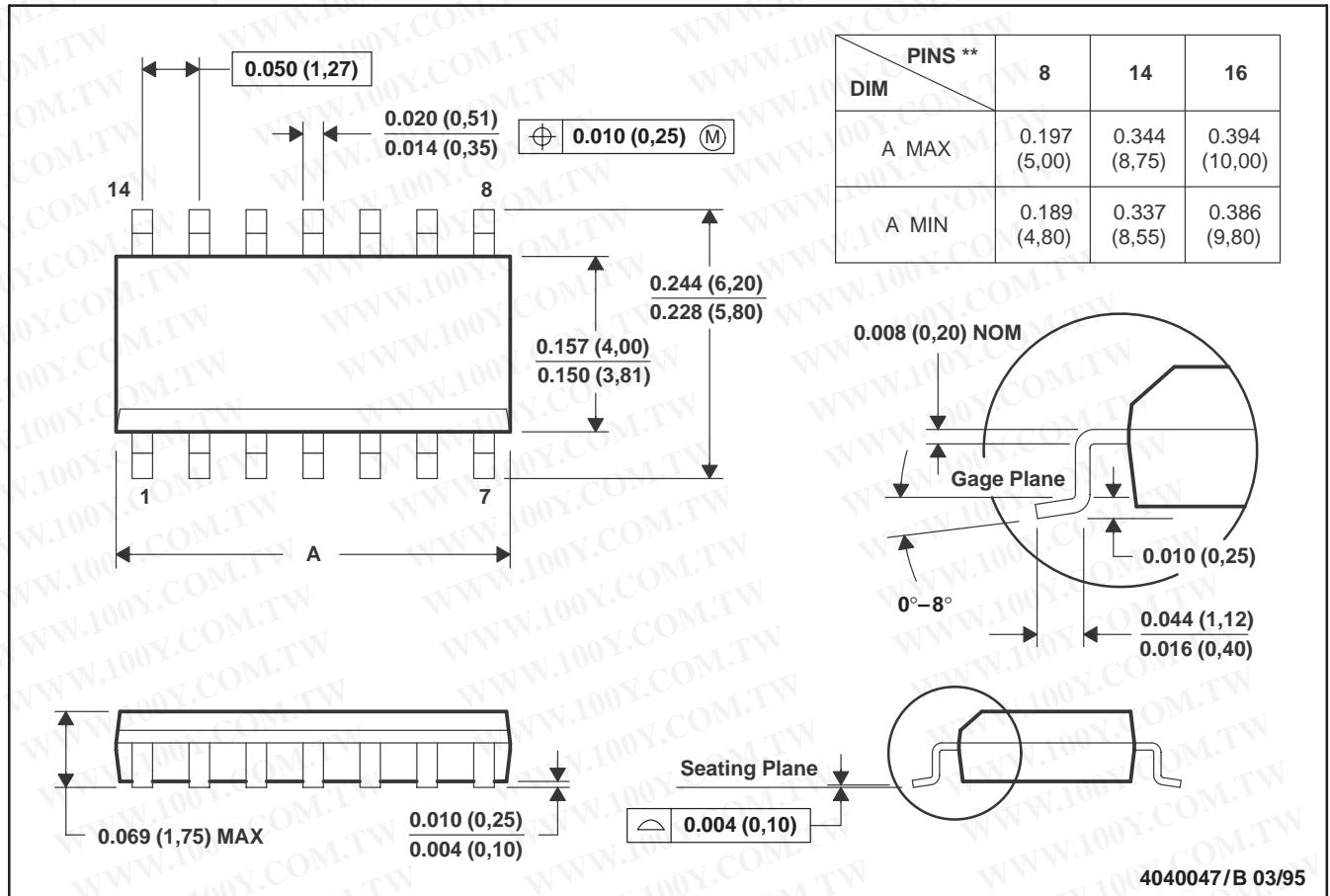

- NOTES: A. All linear dimensions are in inches (millimeters).  
 B. This drawing is subject to change without notice.  
 C. Body dimensions do not include mold flash or protrusion, not to exceed 0.006 (0,15).  
 D. Four center pins are connected to die mount pad.  
 E. Falls within JEDEC MS-012

勝特力材料 886-3-5753170  
 勝特力电子(上海) 86-21-34970699  
 勝特力电子(深圳) 86-755-83298787  
[Http://www.100y.com.tw](http://www.100y.com.tw)

TLE202x, TLE202xA, TLE202xB, TLE202xY  
 EXCALIBUR HIGH-SPEED LOW-POWER PRECISION  
 OPERATIONAL AMPLIFIERS

SLOS191 – FEBRUARY 1997

MECHANICAL INFORMATION

DB (R-PDSO-G\*\*)

PLASTIC SMALL-OUTLINE PACKAGE

28 PIN SHOWN

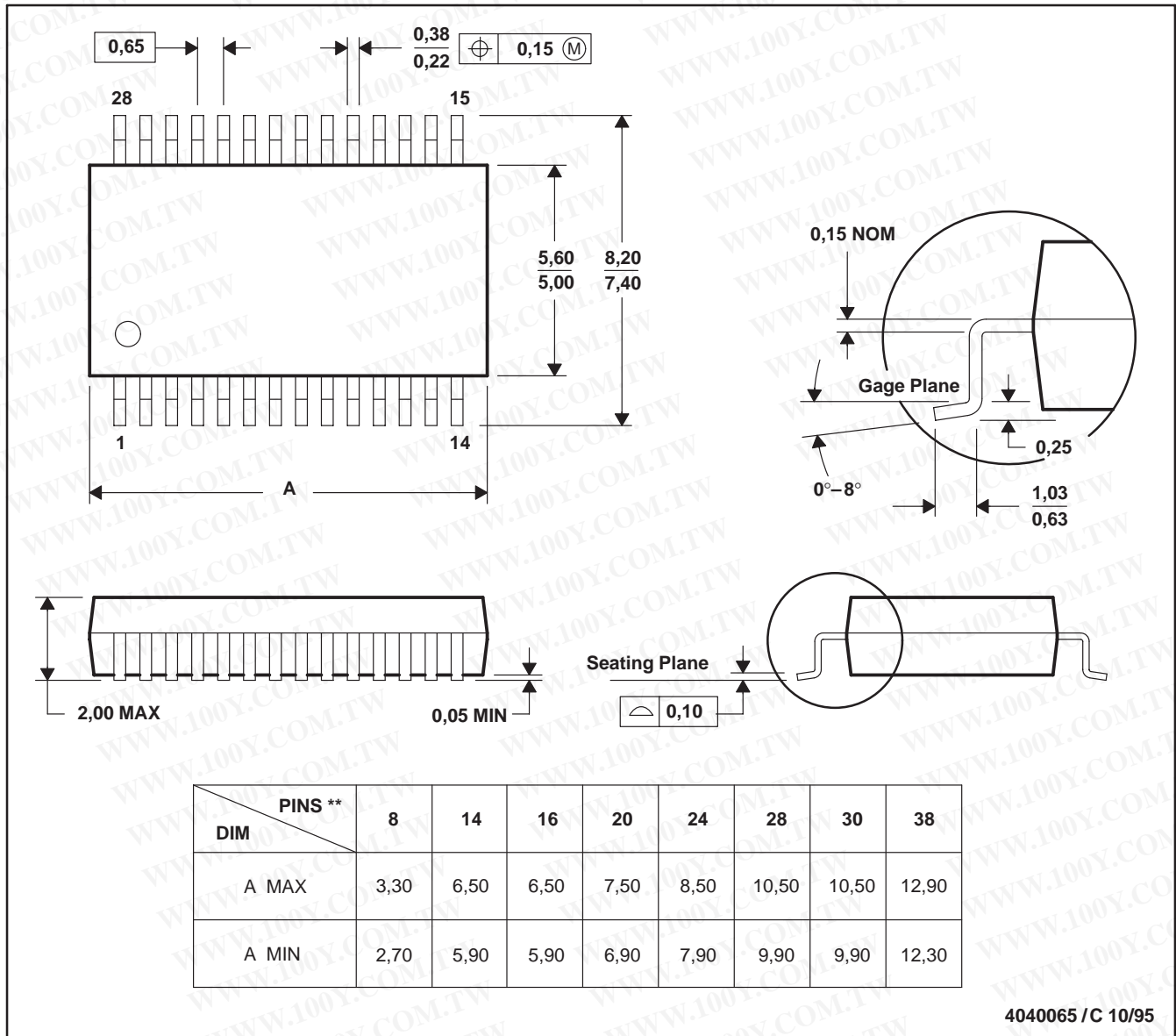

- NOTES: A. All linear dimensions are in millimeters.  
 B. This drawing is subject to change without notice.  
 C. Body dimensions do not include mold flash or protrusion not to exceed 0,15.  
 D. Falls within JEDEC MO-150

勝特力材料 886-3-5753170  
 勝特力电子(上海) 86-21-34970699  
 勝特力电子(深圳) 86-755-83298787  
[Http://www.100y.com.tw](http://www.100y.com.tw)



POST OFFICE BOX 655303 • DALLAS, TEXAS 75265

TLE202x, TLE202xA, TLE202xB, TLE202xY  
 EXCALIBUR HIGH-SPEED LOW-POWER PRECISION  
 OPERATIONAL AMPLIFIERS

SLOS191 – FEBRUARY 1997

MECHANICAL INFORMATION

DW (R-PDSO-G\*\*)

PLASTIC SMALL-OUTLINE PACKAGE

16 PIN SHOWN

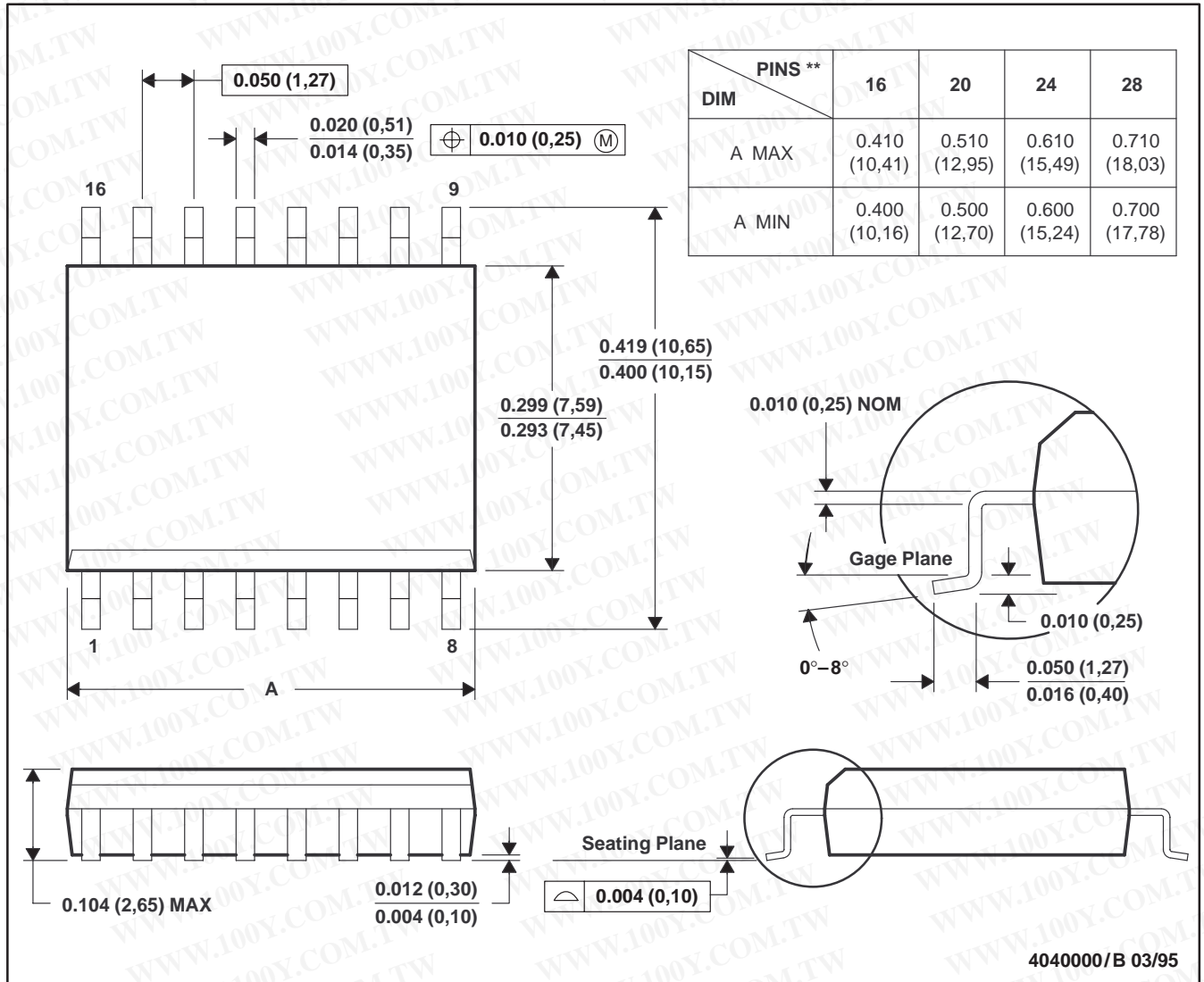

- NOTES: A. All linear dimensions are in inches (millimeters).  
 B. This drawing is subject to change without notice.  
 C. Body dimensions do not include mold flash or protrusion not to exceed 0.006 (0,15).  
 D. Falls within JEDEC MS-013

勝特力材料 886-3-5753170  
 勝特力电子(上海) 86-21-34970699  
 勝特力电子(深圳) 86-755-83298787  
[Http://www.100y.com.tw](http://www.100y.com.tw)



# TLE202x, TLE202xA, TLE202xB, TLE202xY EXCALIBUR HIGH-SPEED LOW-POWER PRECISION OPERATIONAL AMPLIFIERS

SLOS191 – FEBRUARY 1997

## MECHANICAL INFORMATION

FK (S-CQCC-N\*\*)

LEADLESS CERAMIC CHIP CARRIER

28 TERMINAL SHOWN

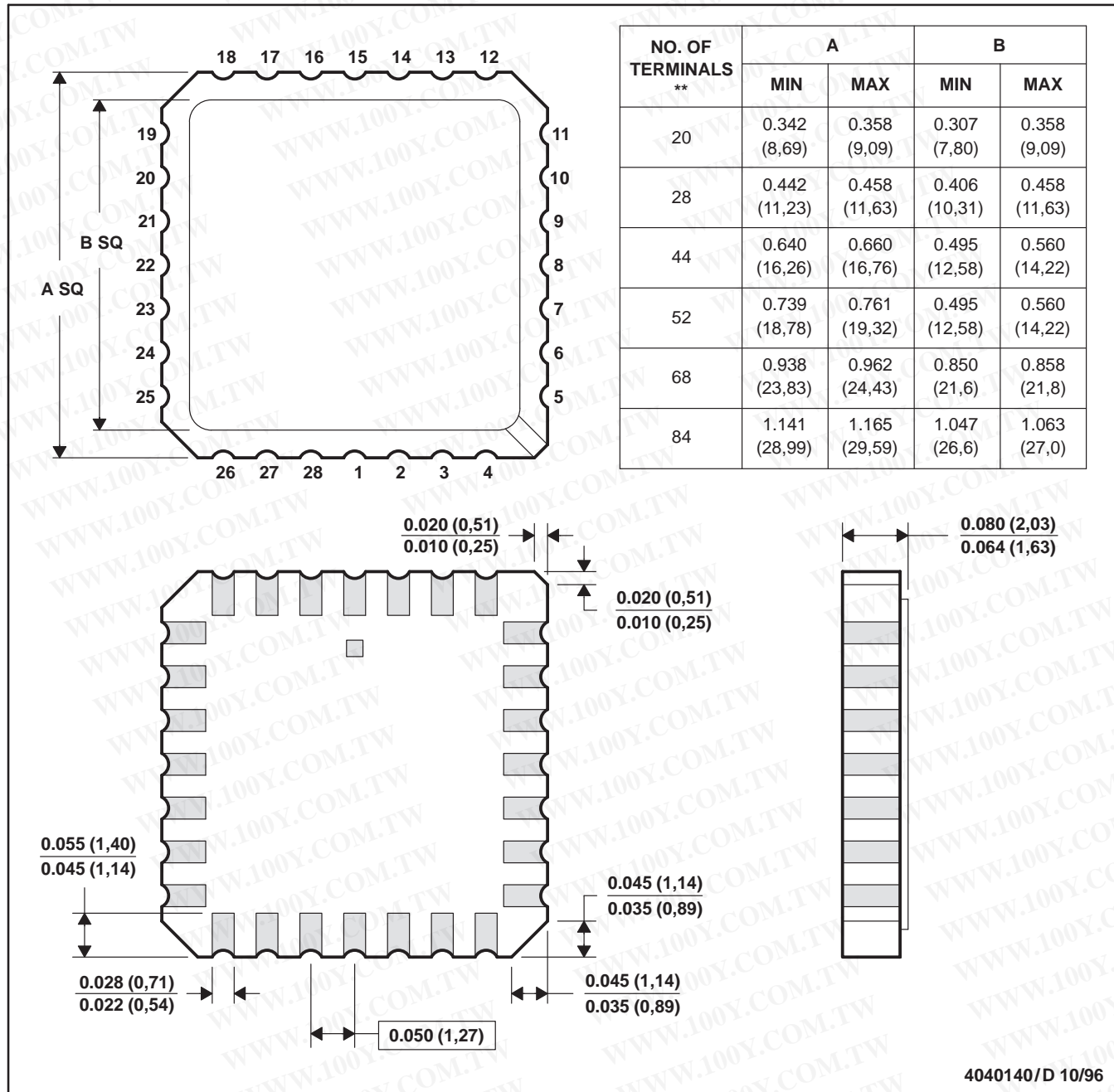

- NOTES: A. All linear dimensions are in inches (millimeters).  
 B. This drawing is subject to change without notice.  
 C. This package can be hermetically sealed with a metal lid.  
 D. The terminals are gold plated.  
 E. Falls within JEDEC MS-004

勝特力材料 886-3-5753170  
 勝特力电子(上海) 86-21-34970699  
 勝特力电子(深圳) 86-755-83298787  
[Http://www.100y.com.tw](http://www.100y.com.tw)



TLE202x, TLE202xA, TLE202xB, TLE202xY  
 EXCALIBUR HIGH-SPEED LOW-POWER PRECISION  
 OPERATIONAL AMPLIFIERS

SLOS191 – FEBRUARY 1997

MECHANICAL INFORMATION

J (R-GDIP-T\*\*)

CERAMIC DUAL-IN-LINE PACKAGE

14 PIN SHOWN

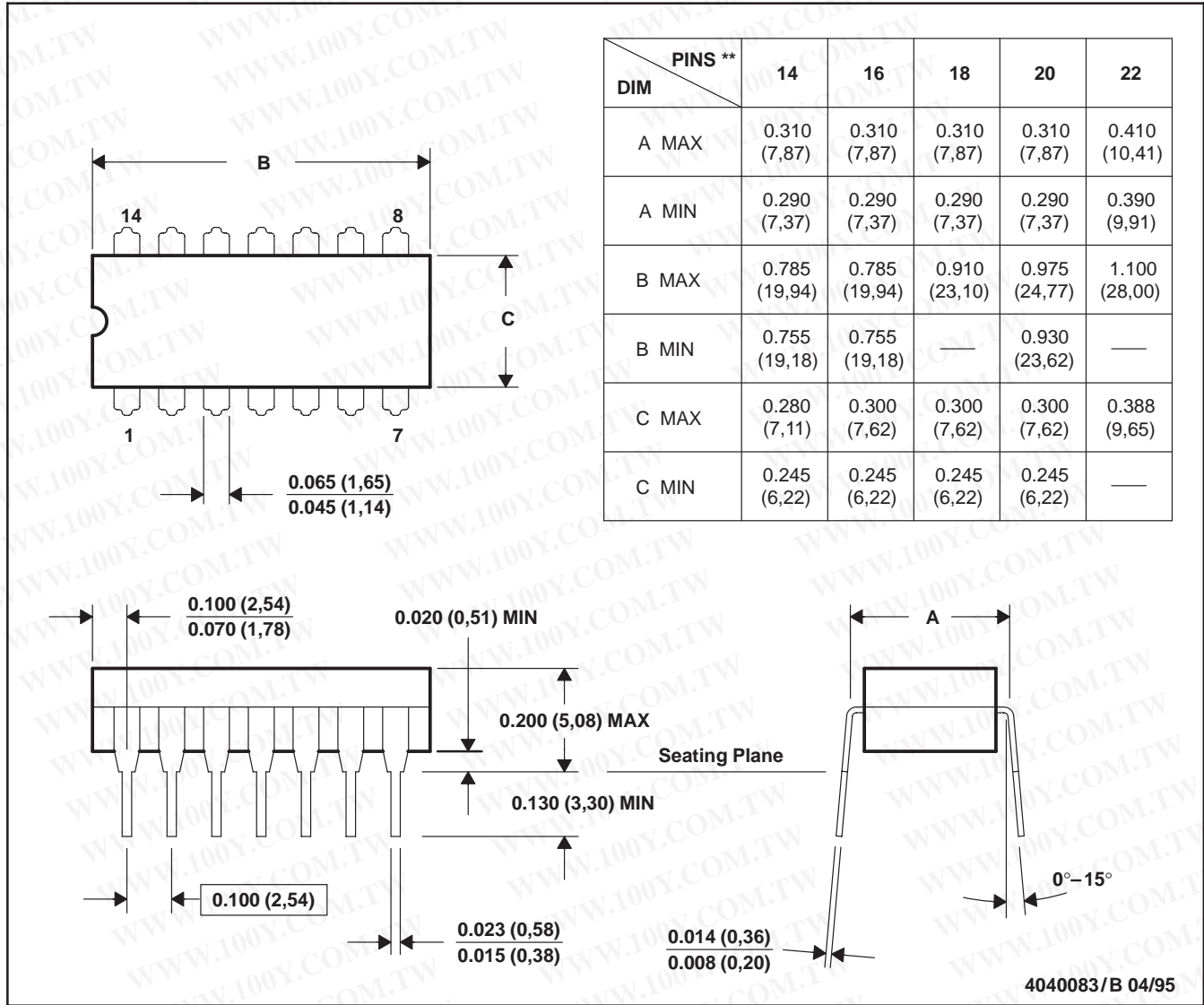

- NOTES: A. All linear dimensions are in inches (millimeters).  
 B. This drawing is subject to change without notice.  
 C. This package can be hermetically sealed with a ceramic lid using glass frit.  
 D. Index point is provided on cap for terminal identification only on press ceramic glass frit seal only.  
 E. Falls within MIL-STD-1835 GDIP1-T14, GDIP1-T16, GDIP1-T18, GDIP1-T20, and GDIP1-T22

勝特力材料 886-3-5753170  
 勝特力电子(上海) 86-21-34970699  
 勝特力电子(深圳) 86-755-83298787  
[Http://www.100y.com.tw](http://www.100y.com.tw)



POST OFFICE BOX 655303 • DALLAS, TEXAS 75265

TLE202x, TLE202xA, TLE202xB, TLE202xY  
 EXCALIBUR HIGH-SPEED LOW-POWER PRECISION  
 OPERATIONAL AMPLIFIERS

SLOS191 – FEBRUARY 1997

MECHANICAL INFORMATION

JG (R-GDIP-T8)

CERAMIC DUAL-IN-LINE PACKAGE

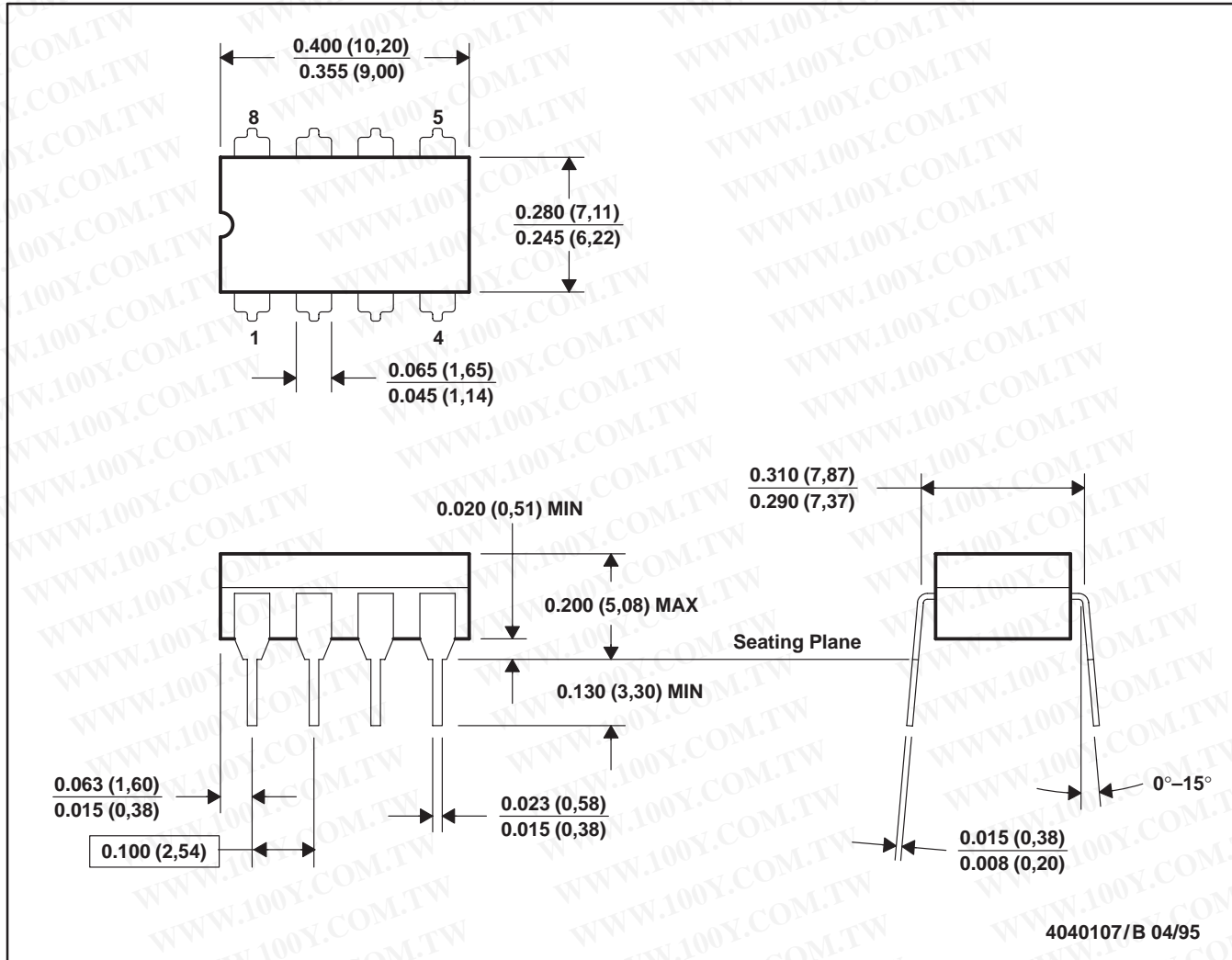

- NOTES: A. All linear dimensions are in inches (millimeters).  
 B. This drawing is subject to change without notice.  
 C. This package can be hermetically sealed with a ceramic lid using glass frit.  
 D. Index point is provided on cap for terminal identification only on press ceramic glass frit seal only  
 E. Falls within MIL-STD-1835 GDIP1-T8

勝特力材料 886-3-5753170  
 勝特力电子(上海) 86-21-34970699  
 勝特力电子(深圳) 86-755-83298787  
[Http://www.100y.com.tw](http://www.100y.com.tw)

TLE202x, TLE202xA, TLE202xB, TLE202xY  
 EXCALIBUR HIGH-SPEED LOW-POWER PRECISION  
 OPERATIONAL AMPLIFIERS

SLOS191 – FEBRUARY 1997

MECHANICAL INFORMATION

N (R-PDIP-T\*\*)

PLASTIC DUAL-IN-LINE PACKAGE

16 PIN SHOWN

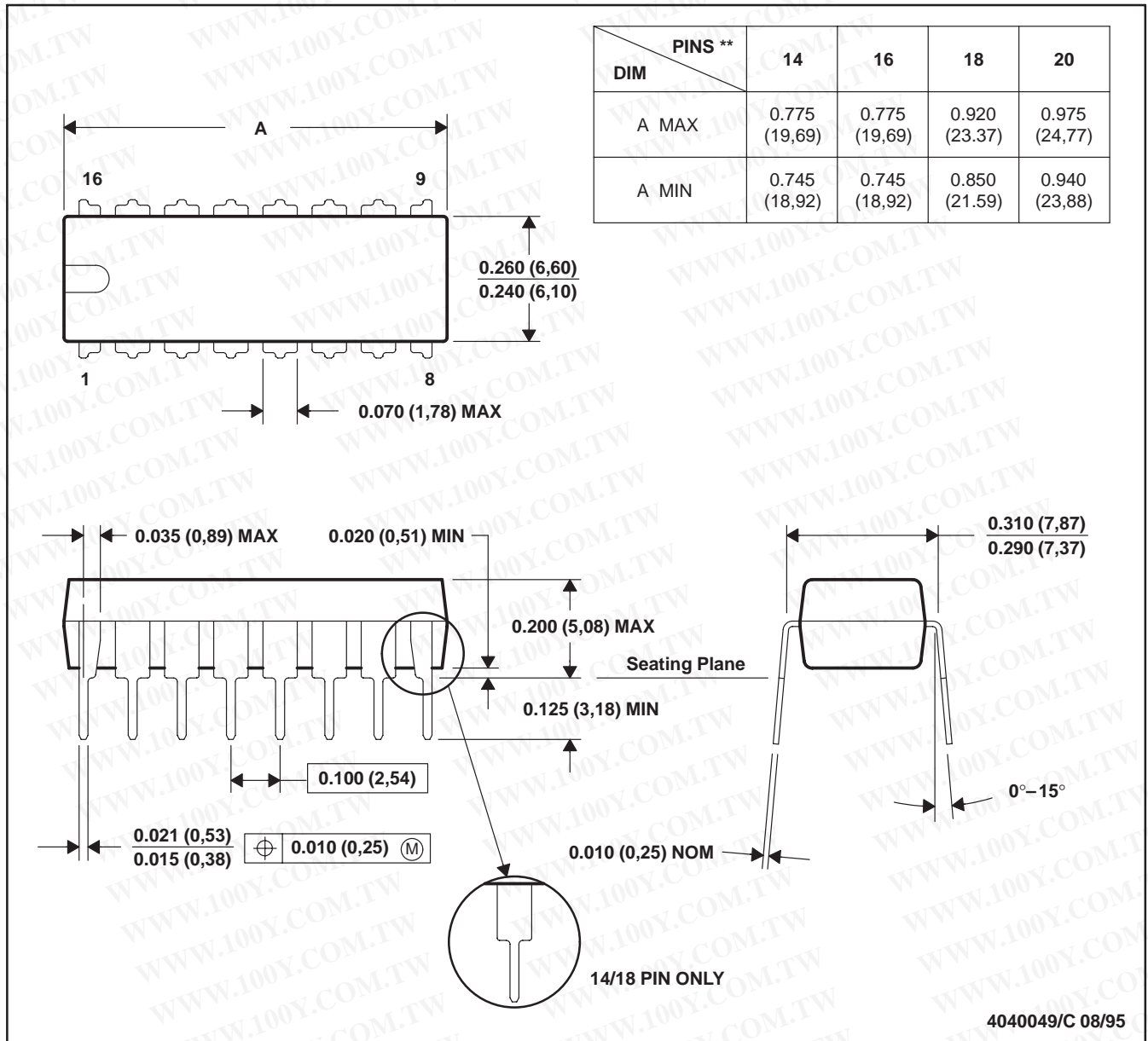

- NOTES: A. All linear dimensions are in inches (millimeters).  
 B. This drawing is subject to change without notice.  
 C. Falls within JEDEC MS-001 (20 pin package is shorter than MS-001.)

勝特力材料 886-3-5753170  
 勝特力电子(上海) 86-21-34970699  
 勝特力电子(深圳) 86-755-83298787  
[Http://www.100y.com.tw](http://www.100y.com.tw)



TLE202x, TLE202xA, TLE202xB, TLE202xY  
 EXCALIBUR HIGH-SPEED LOW-POWER PRECISION  
 OPERATIONAL AMPLIFIERS

SLOS191 – FEBRUARY 1997

MECHANICAL INFORMATION

P (R-PDIP-T8)

PLASTIC DUAL-IN-LINE PACKAGE

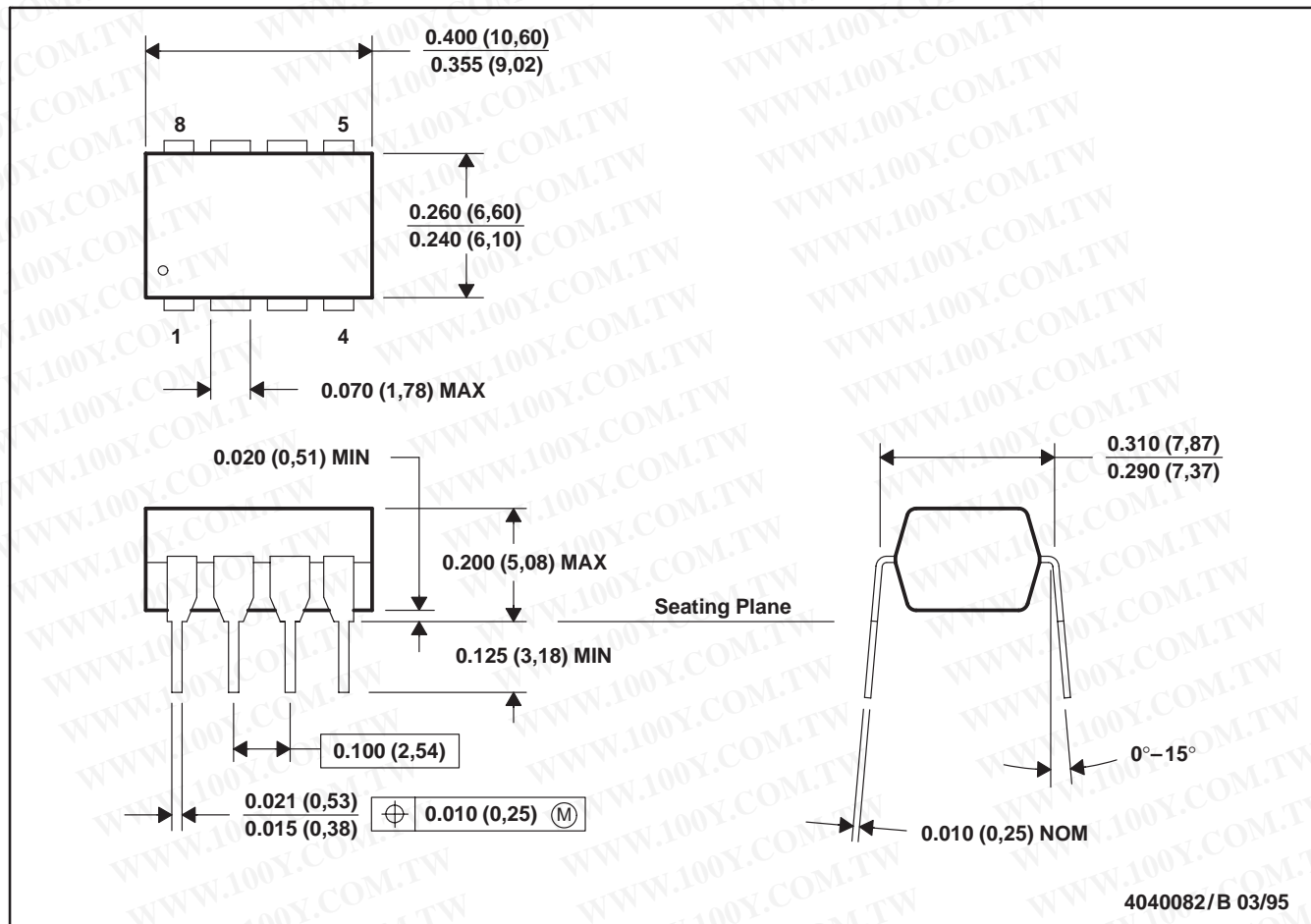

- NOTES: A. All linear dimensions are in inches (millimeters).  
 B. This drawing is subject to change without notice.  
 C. Falls within JEDEC MS-001

勝特力材料 886-3-5753170  
 勝特力电子(上海) 86-21-34970699  
 勝特力电子(深圳) 86-755-83298787  
[Http://www.100y.com.tw](http://www.100y.com.tw)



TLE202x, TLE202xA, TLE202xB, TLE202xY  
 EXCALIBUR HIGH-SPEED LOW-POWER PRECISION  
 OPERATIONAL AMPLIFIERS

SLOS191 – FEBRUARY 1997

MECHANICAL INFORMATION

PW (R-PDSO-G\*\*)

PLASTIC SMALL-OUTLINE PACKAGE

14 PIN SHOWN

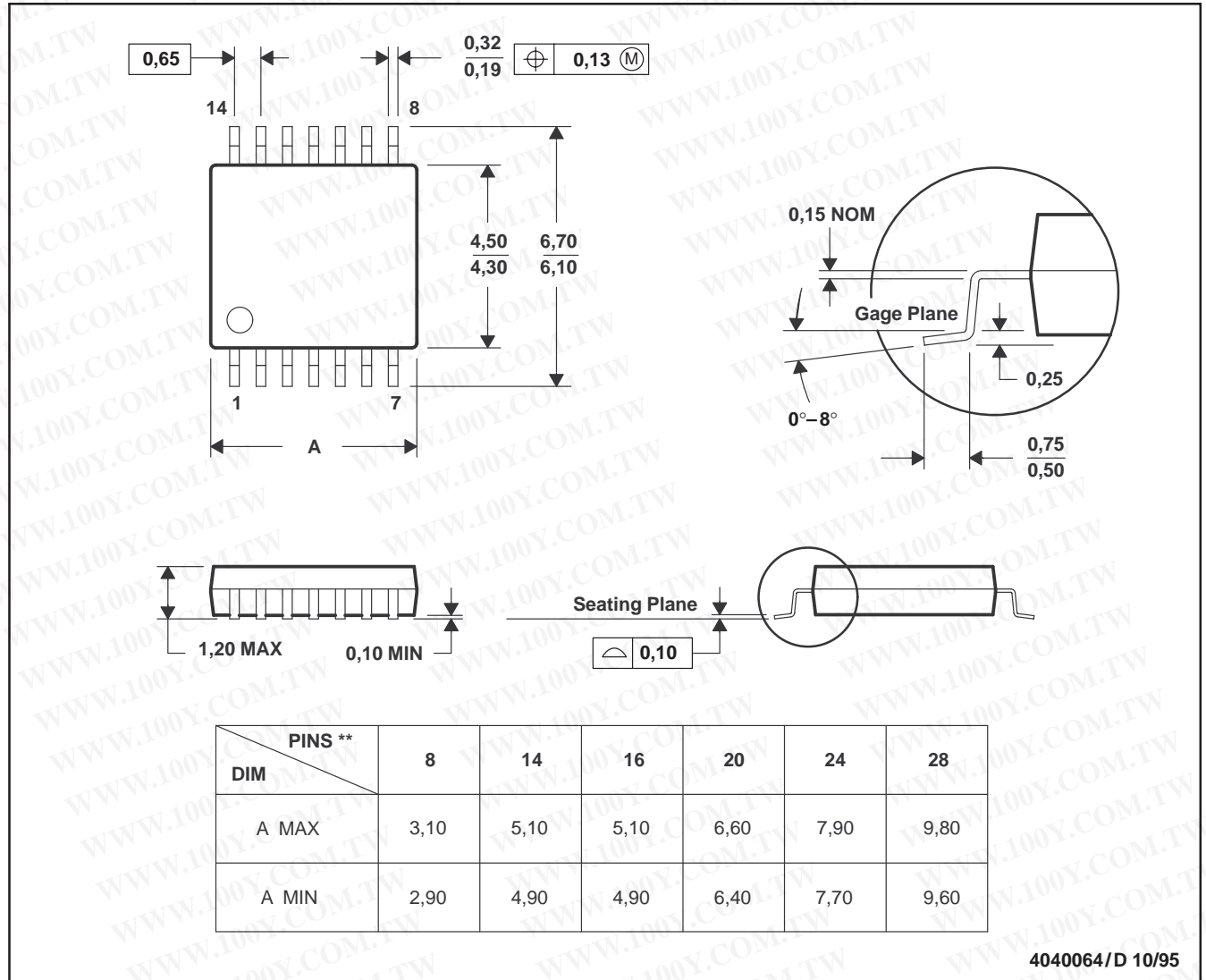

- NOTES: A. All linear dimensions are in millimeters.  
 B. This drawing is subject to change without notice.  
 C. Body dimensions do not include mold flash or protrusion not to exceed 0,15.  
 D. Falls within JEDEC MO-153

勝特力材料 886-3-5753170  
 勝特力电子(上海) 86-21-34970699  
 勝特力电子(深圳) 86-755-83298787  
[Http://www.100y.com.tw](http://www.100y.com.tw)

## IMPORTANT NOTICE

Texas Instruments and its subsidiaries (TI) reserve the right to make changes to their products or to discontinue any product or service without notice, and advise customers to obtain the latest version of relevant information to verify, before placing orders, that information being relied on is current and complete. All products are sold subject to the terms and conditions of sale supplied at the time of order acknowledgement, including those pertaining to warranty, patent infringement, and limitation of liability.

TI warrants performance of its semiconductor products to the specifications applicable at the time of sale in accordance with TI's standard warranty. Testing and other quality control techniques are utilized to the extent TI deems necessary to support this warranty. Specific testing of all parameters of each device is not necessarily performed, except those mandated by government requirements.

CERTAIN APPLICATIONS USING SEMICONDUCTOR PRODUCTS MAY INVOLVE POTENTIAL RISKS OF DEATH, PERSONAL INJURY, OR SEVERE PROPERTY OR ENVIRONMENTAL DAMAGE ("CRITICAL APPLICATIONS"). TI SEMICONDUCTOR PRODUCTS ARE NOT DESIGNED, AUTHORIZED, OR WARRANTED TO BE SUITABLE FOR USE IN LIFE-SUPPORT DEVICES OR SYSTEMS OR OTHER CRITICAL APPLICATIONS. INCLUSION OF TI PRODUCTS IN SUCH APPLICATIONS IS UNDERSTOOD TO BE FULLY AT THE CUSTOMER'S RISK.

In order to minimize risks associated with the customer's applications, adequate design and operating safeguards must be provided by the customer to minimize inherent or procedural hazards.

TI assumes no liability for applications assistance or customer product design. TI does not warrant or represent that any license, either express or implied, is granted under any patent right, copyright, mask work right, or other intellectual property right of TI covering or relating to any combination, machine, or process in which such semiconductor products or services might be or are used. TI's publication of information regarding any third party's products or services does not constitute TI's approval, warranty or endorsement thereof.

勝特力材料 886-3-5753170  
勝特力电子(上海) 86-21-34970699  
勝特力电子(深圳) 86-755-83298787  
[Http://www.100y.com.tw](http://www.100y.com.tw)

Copyright © 1998, Texas Instruments Incorporated