



3-Channel HDTV Video Amplifier With 5th-Order Filters and 6-dB Gain

FEATURES

- 3 HDTV Video Amplifiers for Y'P_BP_R' 720p and 1080i, G'B'R' (R'G'B'), VGA/SVGA/XGA
- Integrated Low-Pass Filters
 - 5th-Order 36-MHz (–3 dB) Butterworth Filter
 - –1 dB Passband Bandwidth at 31 MHz
 - 30 dB Attenuation at 74 MHz
- Versatile Input Biasing
 - DC-Coupled With 140-mV Input Shift
 - AC-Coupled with Sync-Tip Clamp
 - Allows AC-Coupled With Biasing
- Built-in 6-dB Gain (2V/V)
- 3-V to 5-V Single Supply Operation
- Rail-to-Rail Output:
 - Output Swings Within 100 mV From the Rails Allowing AC or DC Output Coupling
 - Supports Driving 2 Lines per Channel
- Low 18.3-mA at 3.3-V Total Quiescent Current
- Low Differential Gain/Phase of 0.1% / 0.1°
- SOIC-8 Package

APPLICATIONS

- Set Top Box Output Video Buffering
- PVR/DVDR Output Buffering
- USB/Portable Low Power Video Buffering

DESCRIPTION

Fabricated using the Silicon-Germanium (SiGe) BiCom-III process, the THS7316 is a low power single-supply 3-V to 5-V, 3-channel integrated video buffer. It incorporates a 5th-order modified Butterworth filter which is useful as a DAC reconstruction filter or an ADC anti-aliasing filter. The 36-MHz filter is a perfect choice for HDTV video which includes Y'P_BP_R' 720p/1080i, G'B'R' (R'G'B'), and VGA/SVGA/XGA signals.

As part of the THS7316 flexibility, the input can be configured for ac or dc coupled inputs. The DC + 140-mV input offset shift to allow for a full sync dynamic range at the output with 0-V input. The AC coupled modes include a transparent sync-tip clamp option for signals with sync such as Y' or Green with sync. AC-coupled biasing for P_BP_R'/Non-sync channels can be achieved by adding an external resistor.

The THS7316 is the perfect choice for all output buffer applications. Its rail-to-rail output stage with 6-dB gain allows for both ac and dc line driving. The ability to drive 2 video lines per channel, or 75-Ω loads, allows for maximum flexibility as a video line driver. The 18.3-mA total quiescent current makes it an excellent choice for USB powered, portable, or other power sensitive video applications.

The THS7316 is available in a small SOIC-8 package that is RoHS compliant.

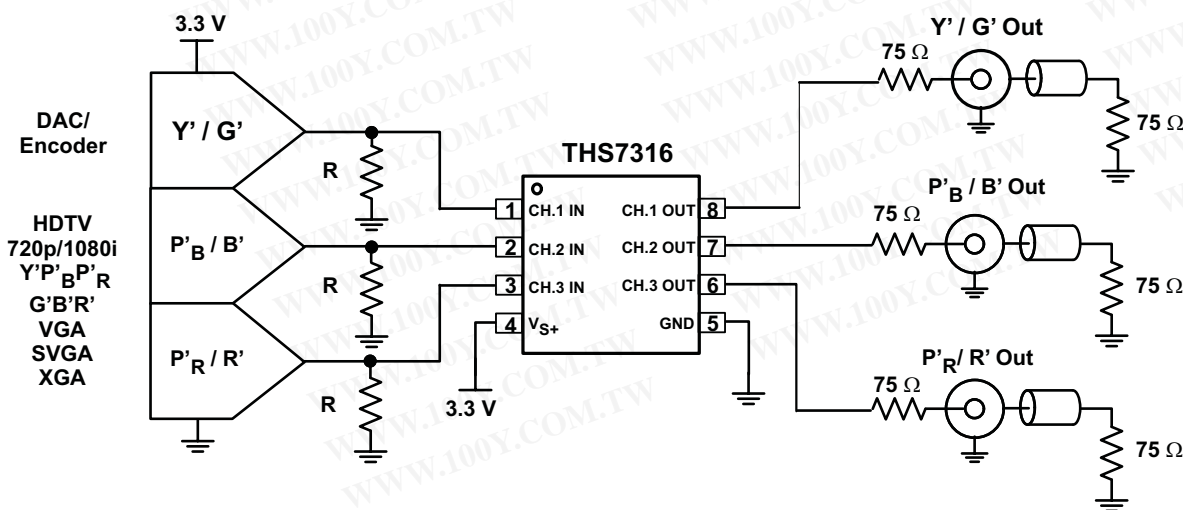

Figure 1. 3.3-V Single-Supply DC-Input/DC Output Coupled Video Line Driver



Please be aware that an important notice concerning availability, standard warranty, and use in critical applications of Texas Instruments semiconductor products and disclaimers thereto appears at the end of this data sheet.



This integrated circuit can be damaged by ESD. Texas Instruments recommends that all integrated circuits be handled with appropriate precautions. Failure to observe proper handling and installation procedures can cause damage.

ESD damage can range from subtle performance degradation to complete device failure. Precision integrated circuits may be more susceptible to damage because very small parametric changes could cause the device not to meet its published specifications.

PACKAGING/ORDERING INFORMATION

PACKAGED DEVICES	PACKAGE TYPE ⁽¹⁾	TRANSPORT MEDIA, QUANTITY
THS7316D	SOIC-8	Rails, 75
THS7316DR		Tape and Reel, 2500

(1) For the most current package and ordering information, see the Package Option Addendum at the end of this document, or see the TI Web site at www.ti.com.

ABSOLUTE MAXIMUM RATINGS

over operating free-air temperature range (unless otherwise noted) ⁽¹⁾

	VALUE	UNIT
Supply voltage, V_{S+} to GND	5.5	V
V_I Input voltage	- 0.4 V to V_{S+}	V
I_O Output current	±90	mA
Continuous power dissipation	See Dissipation Rating Table	
T_J Maximum junction temperature, any condition ⁽²⁾	150	°C
T_J Maximum junction temperature, continuous operation, long term reliability ⁽³⁾	125	°C
T_{stg} Storage temperature range	-65 to 150	°C
ESD ratings	HBM	2000
	CDM	1500
	MM	200

(1) Stresses above those listed under absolute maximum ratings may cause permanent damage to the device. These are stress ratings only and functional operation of the device at these or any other conditions beyond those indicated under *recommended operating conditions* is not implied. Exposure to absolute maximum rated conditions for extended periods may degrade device reliability.

(2) The absolute maximum junction temperature under any condition is limited by the constraints of the silicon process.

(3) The absolute maximum junction temperature for continuous operation is limited by the package constraints. Operation above this temperature may result in reduced reliability and/or lifetime of the device.

DISSIPATION RATINGS

PACKAGE	θ_{JC} (°C/W)	θ_{JA} (°C/W)	POWER RATING ⁽¹⁾ ($T_J = 125^\circ\text{C}$)	
			$T_A = 25^\circ\text{C}$	$T_A = 85^\circ\text{C}$
SOIC-8 (D)	16.8	130 ⁽²⁾	769 mW	308 mW

(1) Power rating is determined with a junction temperature of 125°C. This is the point where performance starts to degrade and long-term reliability starts to be reduced. Thermal management of the final PCB should strive to keep the junction temperature at or below 125°C for best performance and reliability.

(2) This data was taken with the JEDEC High-K test PCB. For the JEDEC low-K test PCB, the θ_{JA} is 196°C/W.

RECOMMENDED OPERATING CONDITIONS

	MIN	MAX	UNIT
V_{S+} Supply voltage	3	5	V
T_A Ambient temperature	-40	85	°C

勝特力材料 886-3-5753170
 勝特力电子(上海) 86-21-54151736
 勝特力电子(深圳) 86-755-83298787
[Http://www.100y.com.tw](http://www.100y.com.tw)

FUNCTIONAL DIAGRAM

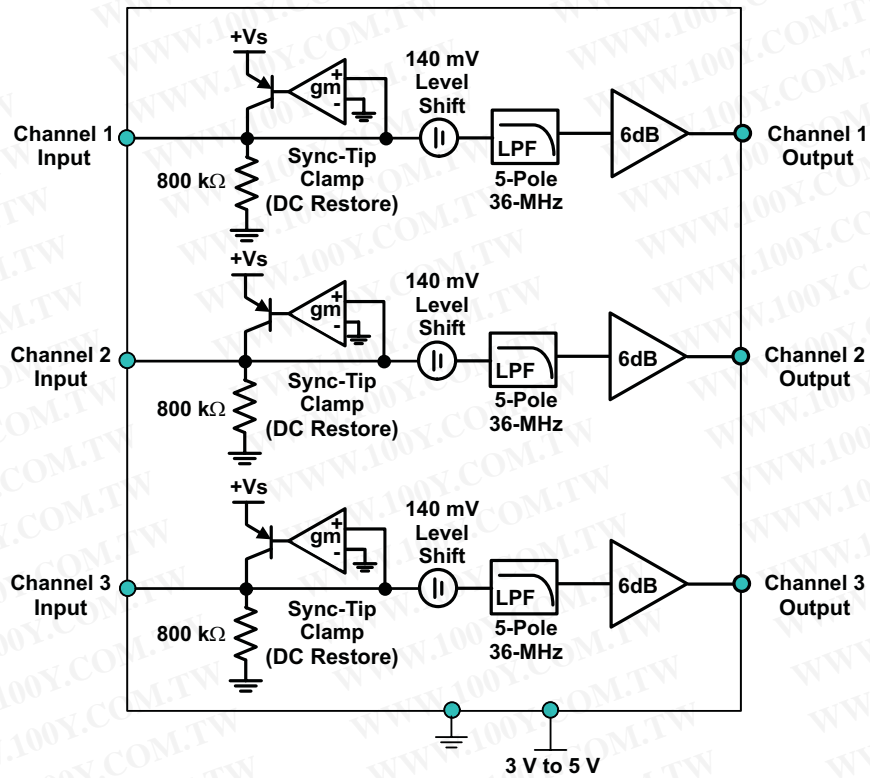

PIN CONFIGURATION

SOIC-8 (D)
(TOP VIEW)
THS7316

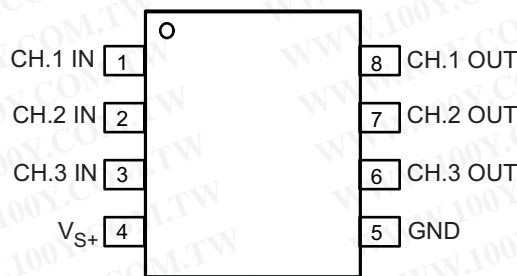

TERMINAL FUNCTIONS

TERMINAL		I/O	DESCRIPTION
NAME	NO. SOIC-8		
CH. 1 – INPUT	1	I	Video Input – Channel 1
CH. 2 – INPUT	2	I	Video Input – Channel 2
CH. 3 – INPUT	3	I	Video Input – Channel 3
+Vs	4	I	Positive Power Supply Pin – connect to 3 V to 5 V.
GND	5	I	Ground Pin for all internal circuitry.
CH. 3 – OUTPUT	6	O	Video Output – Channel 3
CH. 2 – OUTPUT	7	O	Video Output – Channel 2
CH. 1 – OUTPUT	8	O	Video Output – Channel 1

勝特力材料 886-3-5753170
 勝特力电子(上海) 86-21-54151736
 勝特力电子(深圳) 86-755-83298787
[Http://www.100y.com.tw](http://www.100y.com.tw)

THS7316

SLOS521–MARCH 2007

ELECTRICAL CHARACTERISTICS $V_{S+} = 3.3\text{ V}$:

$R_L = 150\ \Omega$ to GND – Reference [Figure 2](#) and [Figure 3](#) (unless otherwise noted)

PARAMETER	TEST CONDITIONS	TYP	OVER TEMPERATURE				UNITS	MIN/ MAX/ TYP
		25°C	25°C	0°C to 70°C	–40°C to 85°C			
AC PERFORMANCE								
Small-signal bandwidth (–3dB)	$V_O = 0.2 V_{PP}^{(1)}$	36	31/43	30/44	30/44	MHz	Min/Max	
Large-signal bandwidth (–3dB)	$V_O = 2 V_{PP}^{(1)}$	36	31/43	30/44	30/44	MHz	Min/Max	
–1 dB Passband bandwidth		31				MHz	Typ	
Attenuation	$f = 27\text{ MHz}^{(2)}$	0.3	–0.3/2.4	–0.35/2.4	–0.4/2.6	dB	Min/Max	
With respect to 100 kHz	$f = 74\text{ MHz}^{(2)}$	30	20	19	19	dB	Min	
Group delay	$f = 100\text{ kHz}$	16.2				ns	Typ	
Group delay variation with respect to 100 kHz	$f = 27\text{ MHz}$	5.4				ns	Typ	
Channel-to-channel delay		0.3				ns	Typ	
Differential gain	NTSC / PAL	0.1 / 0.15%					Typ	
Differential phase	NTSC / PAL	0.1 / 0.1				°	Typ	
Total harmonic distortion	$f = 1\text{ MHz}; V_O = 2 V_{PP}$	–70				dB	Typ	
Signal to noise ratio	No Weighting, 100 kHz to 37.5 MHz	67				dB	Typ	
Channel-to-channel crosstalk	$f = 1\text{ MHz}$	–61				dB	Typ	
AC Gain – All channels		6	5.7/6.3	5.65/6.35	5.65/6.35	dB	Min/Max	
Output Impedance	$f = 10\text{ MHz}$	0.5				Ω	Typ	
DC PERFORMANCE								
Biased output voltage	$V_I = 0\text{ V}$	285	210/370	200/380	190/390	mV	Min/Max	
Input voltage range	DC input, limited by output	–0.1/1.46				V	Typ	
Sync tip clamp charge current	$V_I = -0.1\text{ V}$	360				μA	Typ	
Input resistance		800				k Ω	Typ	
Input capacitance		2				pF	Typ	
OUTPUT CHARACTERISTICS								
High output voltage swing	$R_L = 150\ \Omega$ to 1.65V	3.15				V	Typ	
	$R_L = 150\ \Omega$ to GND	3.1	2.85	2.75	2.75	V	Min	
	$R_L = 75\ \Omega$ to 1.65V	3.1				V	Typ	
	$R_L = 75\ \Omega$ to GND	3.0				V	Typ	
Low output voltage swing	$R_L = 150\ \Omega$ to 1.65V ($V_I = -0.15\text{ V}$)	0.14				V	Typ	
	$R_L = 150\ \Omega$ to GND ($V_I = -0.15\text{ V}$)	0.08	0.17	0.2	0.21	V	Max	
	$R_L = 75\ \Omega$ to 1.65V ($V_I = -0.15\text{ V}$)	0.3				V	Typ	
	$R_L = 75\ \Omega$ to GND ($V_I = -0.15\text{ V}$)	0.1				V	Typ	
Output current (sourcing)	$R_L = 10\ \Omega$ to 1.65V	80				mA	Typ	
Output current (sinking)	$R_L = 10\ \Omega$ to 1.65V	70				mA	Typ	
POWER SUPPLY								
Maximum operating voltage		3.3	5.5	5.5	5.5	V	Max	
Minimum operating voltage		3.3	2.85	2.85	2.85	V	Min	
Maximum quiescent current	$V_I = 0\text{ V}$	18.3	22.5	23	23.4	mA	Max	
Minimum quiescent current	$V_I = 0\text{ V}$	18.3	14	13.6	13.1	mA	Min	
Power Supply Rejection (+PSRR)		52				dB	Typ	

(1) The Min/Max values listed for this specification are specified by design and characterization only.

(2) 3.3-V Supply Filter specifications are specified by 100% testing at 5-V supply along with design and characterization only.

ELECTRICAL CHARACTERISTICS $V_{S+} = 5\text{ V}$:
 $R_L = 150\Omega$ to GND – Reference [Figure 2](#) and [Figure 3](#) (unless otherwise noted)

PARAMETER	TEST CONDITIONS	TYP	OVER TEMPERATURE				UNITS	MIN/ MAX/ TYP
		25°C	25°C	0°C to 70°C	–40°C to 85°C			
AC PERFORMANCE								
Small-signal bandwidth (–3dB)	$V_O = 0.2 V_{PP}^{(1)}$	36	31/43	30/44	30/44	MHz	Min/Max	
Large-signal bandwidth (–3dB)	$V_O = 2 V_{PP}^{(1)}$	36	31/43	30/44	30/44	MHz	Min/Max	
–1dB Passband bandwidth		31				MHz	Typ	
Attenuation	$f = 27\text{ MHz}$	0.3	–0.3/2.4	–0.35/2.5	–0.4/2.6	dB	Min/Max	
With respect to 100 kHz	$f = 74\text{ MHz}$	30	20	19	19	dB	Min	
Group delay	$f = 100\text{ kHz}$	16.1				ns	Typ	
Group delay variation with respect to 100kHz	$f = 27\text{ MHz}$	5.4				ns	Typ	
Channel-to-channel delay		0.3				ns	Typ	
Differential gain	NTSC / PAL	0.1 / 0.15%					Typ	
Differential phase	NTSC / PAL	0.1 / 0.1				°	Typ	
Total harmonic distortion	$f = 1\text{ MHz}; V_O = 2 V_{PP}$	–70				dB	Typ	
Signal to noise ratio	No Weighting, 100 kHz to 37.5 MHz	67				dB	Typ	
Channel-to-channel crosstalk	$f = 1\text{ MHz}$	–62				dB	Typ	
AC Gain – All channels		6	5.7/6.3	5.65/6.35	5.65/6.35	dB	Min/Max	
Output Impedance	$f = 10\text{ MHz}$	0.5				Ω	Typ	
DC PERFORMANCE								
Biased output voltage	$V_I = 0\text{ V}$	290	210/370	200/380	190/390	mV	Min/Max	
Input voltage range	Limited by output	–0.1/2.3				V	Typ	
Sync tip clamp charge current	$V_I = -0.1\text{ V}$	380				μA	Typ	
Input resistance		800				k Ω	Typ	
Input capacitance		2				pF	Typ	
OUTPUT CHARACTERISTICS								
High output voltage swing	$R_L = 150\ \Omega$ to 2.5V	4.85				V	Typ	
	$R_L = 150\ \Omega$ to GND	4.7	4.2	4.1	4.1	V	Min	
	$R_L = 75\ \Omega$ to 2.5V	4.7				V	Typ	
	$R_L = 75\ \Omega$ to GND	4.5				V	Typ	
Low output voltage swing	$R_L = 150\ \Omega$ to 2.5V ($V_I = -0.15\text{ V}$)	0.19				V	Typ	
	$R_L = 150\ \Omega$ to GND ($V_I = -0.15\text{ V}$)	0.09	0.23	0.26	0.27	V	Max	
	$R_L = 75\ \Omega$ to 2.5V ($V_I = -0.15\text{ V}$)	0.35				V	Typ	
	$R_L = 75\ \Omega$ to GND ($V_I = -0.15\text{ V}$)	0.1				V	Typ	
Output current (sourcing)	$R_L = 10\ \Omega$ to 2.5 V	90				mA	Typ	
Output current (sinking)	$R_L = 10\ \Omega$ to 2.5 V	85				mA	Typ	
POWER SUPPLY								
Maximum operating voltage		5	5.5	5.5	5.5	V	Max	
Minimum operating voltage		5	2.85	2.85	2.85	V	Min	
Maximum quiescent current	$V_I = 0\text{ V}$	19.3	23	25	26	mA	Max	
Minimum quiescent current	$V_I = 0\text{ V}$	19.3	14.7	14.2	13.8	mA	Min	
Power Supply Rejection (+PSRR)		52				dB	Typ	

(1) The Min/Max values listed for this specification are specified by design and characterization only.

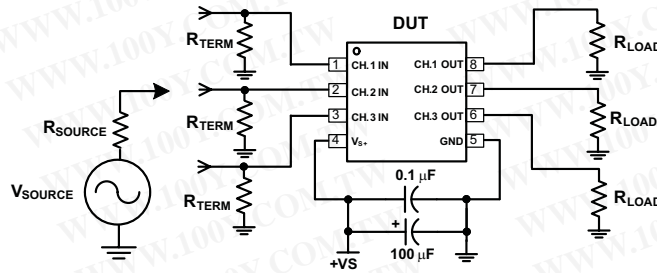

Figure 2. DC Coupled Input and Output Test Circuit

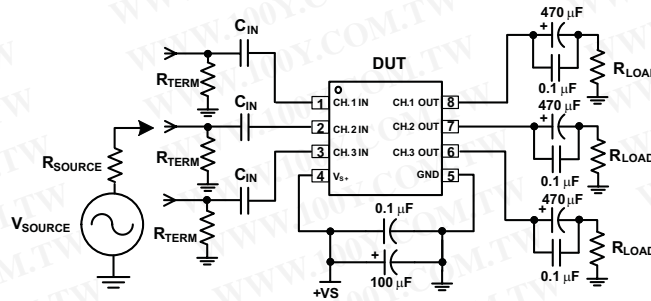

Figure 3. AC Coupled Input and Output Test Circuit

勝特力材料 886-3-5753170
 勝特力电子(上海) 86-21-54151736
 勝特力电子(深圳) 86-755-83298787
[Http://www.100y.com.tw](http://www.100y.com.tw)

TYPICAL CHARACTERISTICS

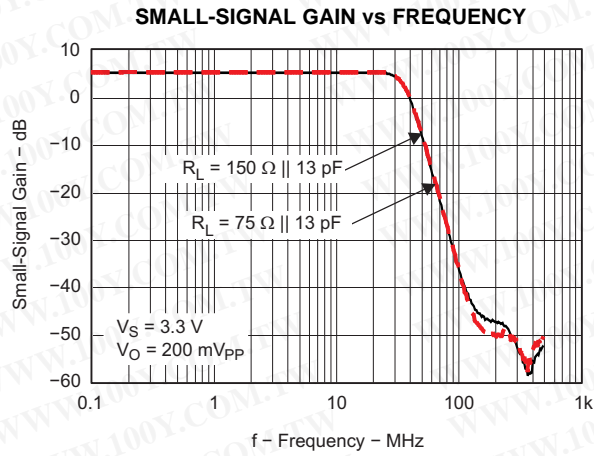

Figure 4.

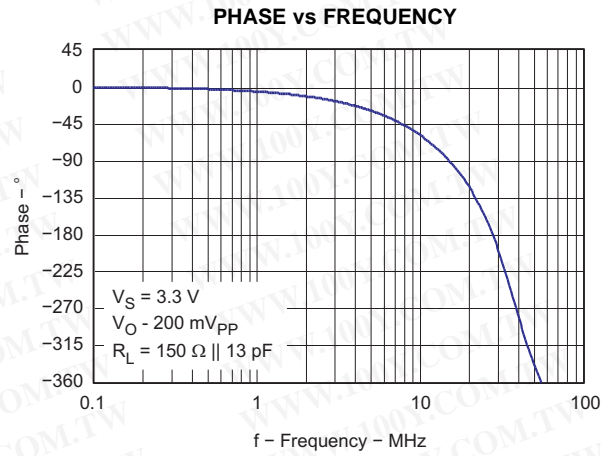

Figure 5.

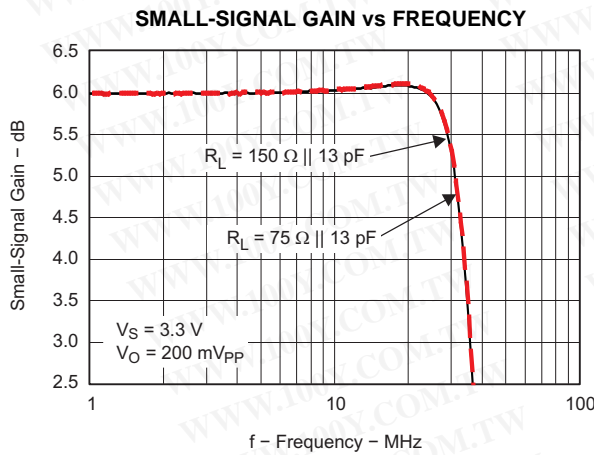

Figure 6.

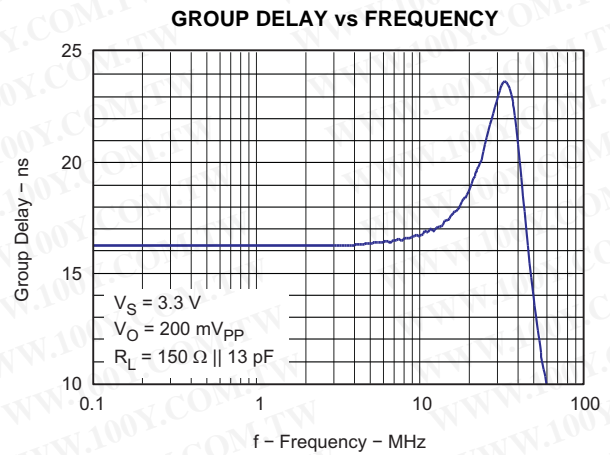

Figure 7.

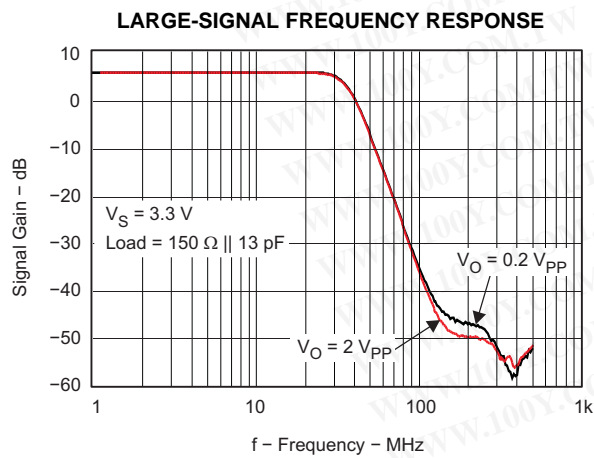

Figure 8.

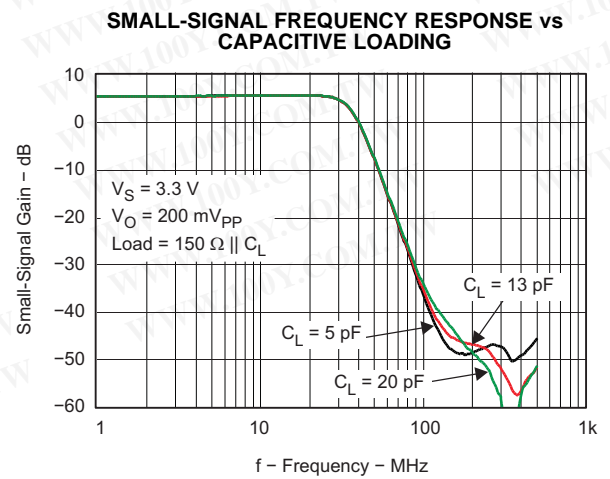

Figure 9.

TYPICAL CHARACTERISTICS (continued)

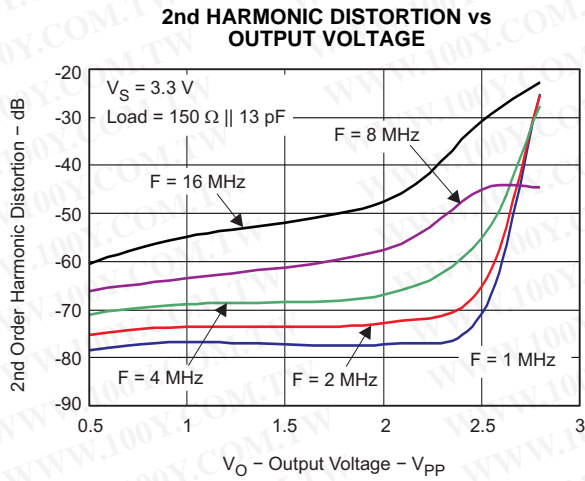

Figure 10.

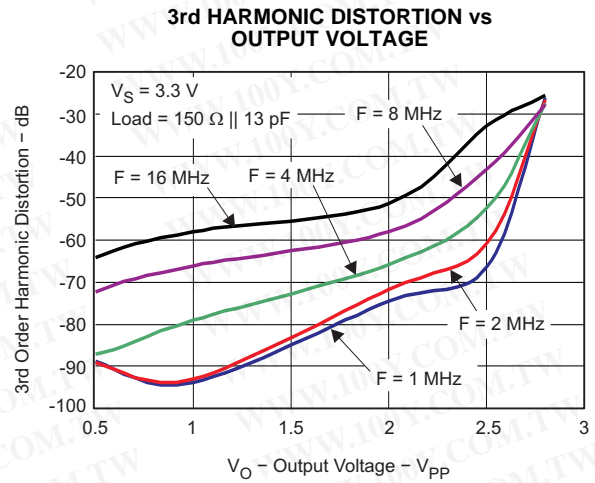

Figure 11.

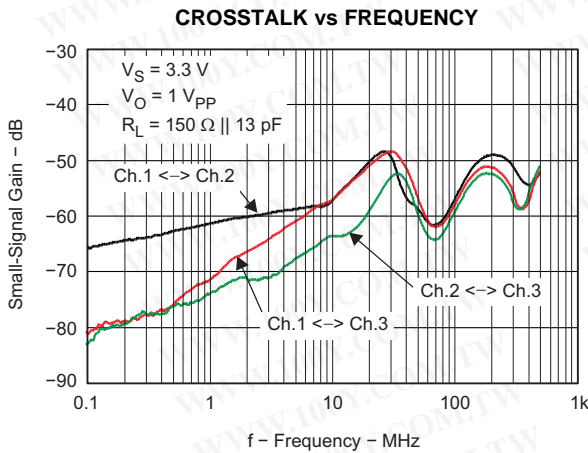

Figure 12.

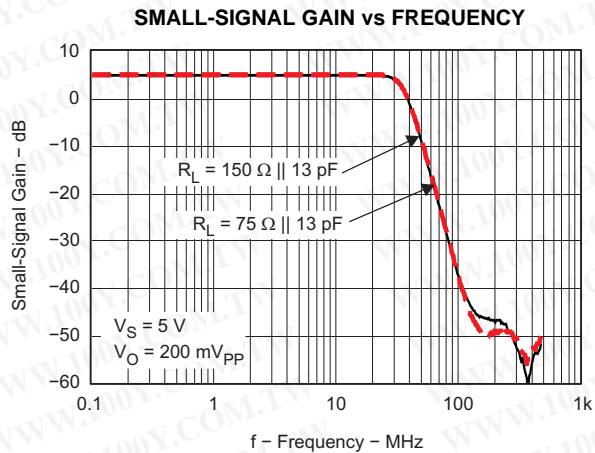

Figure 13.

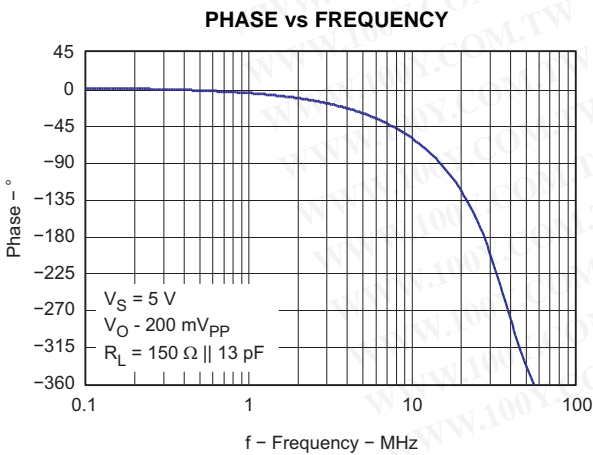

Figure 14.

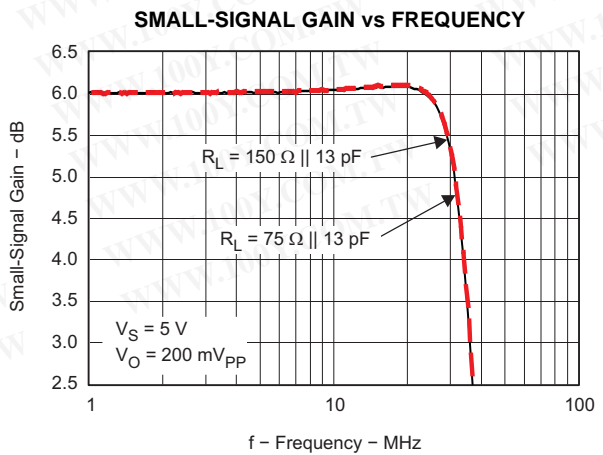

Figure 15.

TYPICAL CHARACTERISTICS (continued)

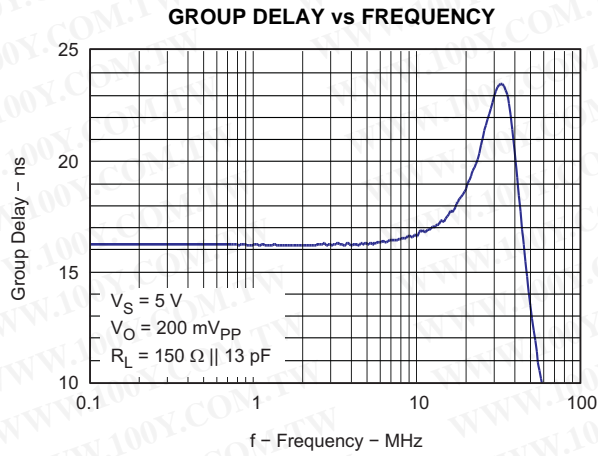

Figure 16.

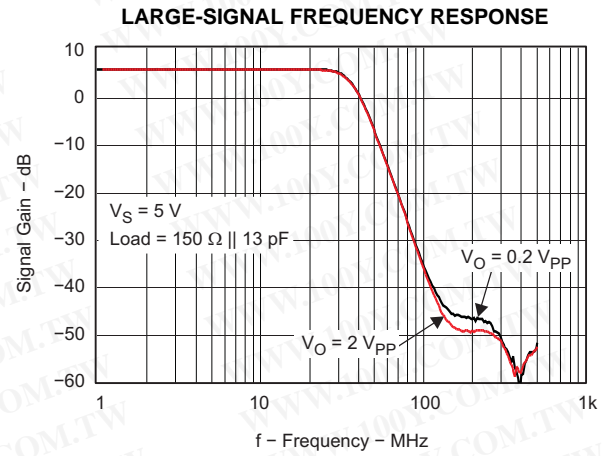

Figure 17.

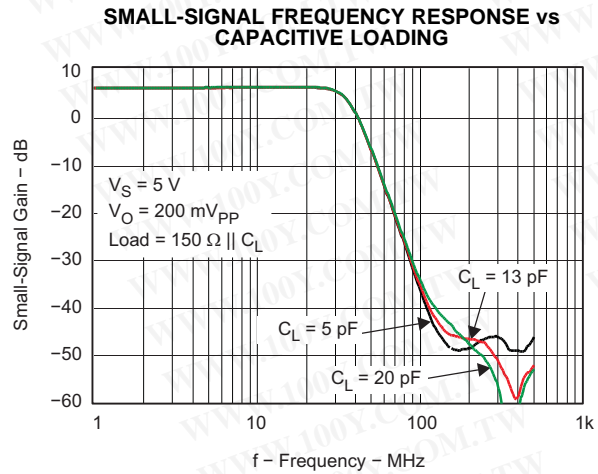

Figure 18.

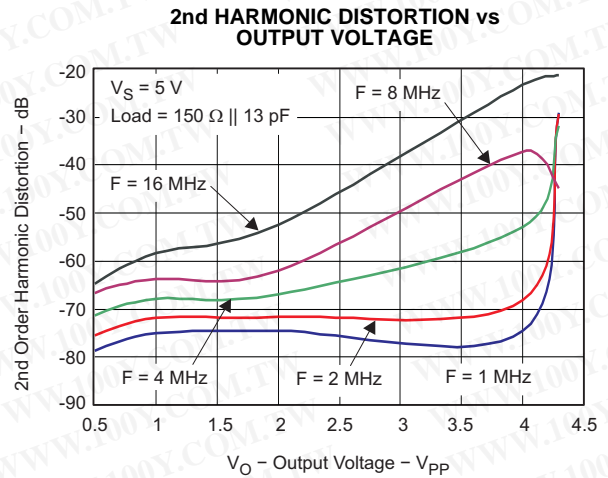

Figure 19.

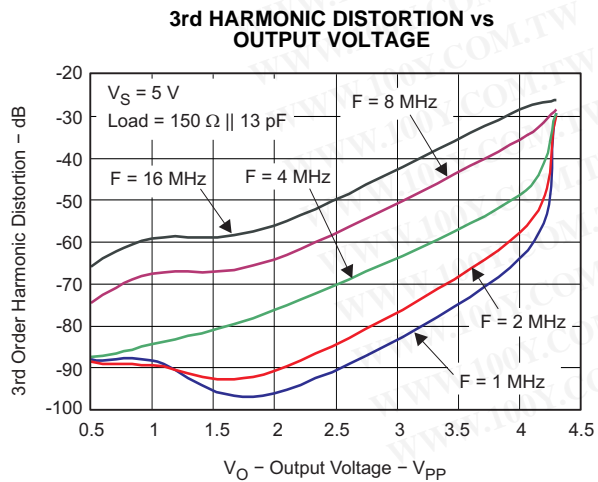

Figure 20.

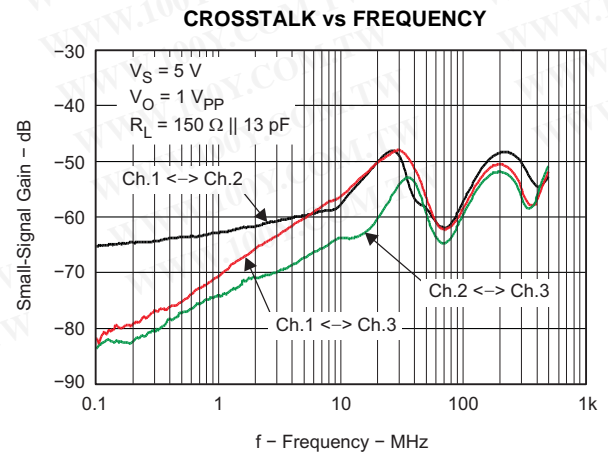

Figure 21.

TYPICAL CHARACTERISTICS (continued)

QUIESCENT CURRENT vs TEMPERATURE

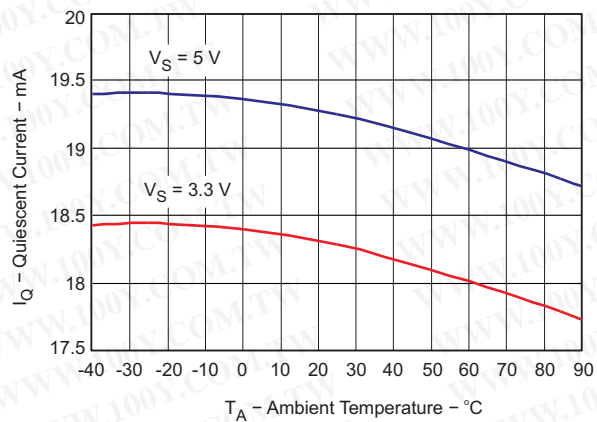

Figure 22.

VOLTAGE GAIN vs TEMPERATURE

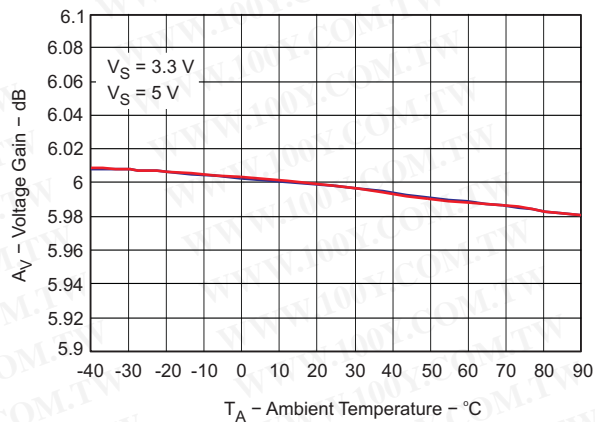

Figure 23.

ATTENUATION at 27 MHz vs TEMPERATURE

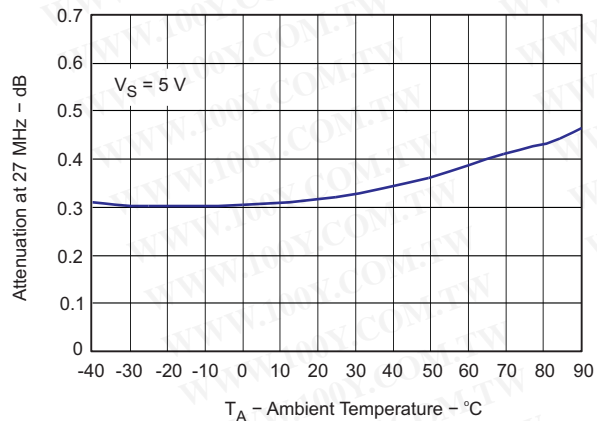

Figure 24.

ATTENUATION at 74 MHz vs TEMPERATURE

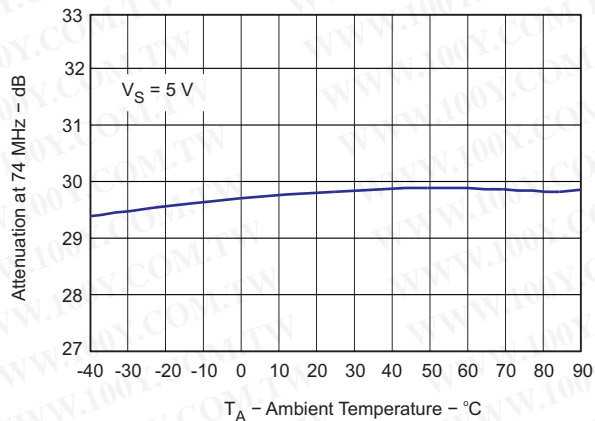

Figure 25.

APPLICATION INFORMATION

The THS7316 is targeted for standard definition video output buffer applications. Although it can be used for numerous other applications, the needs and requirements of the video signal is an important design parameter of the THS7316. Built on the Silicon Germanium (SiGe) BiCom-3 process, the THS7316 incorporates many features not typically found in integrated video parts while consuming low power.

The THS7316 has the following features:

- Single-Supply 3-V to 5-V operation with low total quiescent current of 18.3-mA at 3.3-V and 19.3-mA at 5-V.
- Input configuration accepting DC + Level shift, AC Sync-Tip Clamp.
- AC-Biasing is accomplished with the use of an external pull-up resistor to the positive power supply.
- 5th-Order Low Pass Filter for DAC reconstruction or ADC image rejection:
 - 36-MHz for HDTV, Y'P_BP_R 720p/1080i, G'B'R' (R'G'B'), and Computer VGA/SVGA/XGA signals.
 - Can also be used for SDTV (480i, 576i, CVBS, S-Video), and EDTV (480p and 576p) signals if desired.
- Internal fixed gain of 2 V/V (6 dB) buffer that can drive up to 2 video lines per channel with dc coupling or traditional ac coupling.
- Signal flow-through configuration using an 8-pin SOIC package that complies with the latest (RoHS compatible) and Green manufacturing requirements.

OPERATING VOLTAGE

The THS7316 is designed to operate from 3-V to 5-V over a –40°C to 85°C temperature range. The impact on performance over the entire temperature range is negligible due to the implementation of thin film resistors and high quality – low temperature coefficient capacitors.

The power supply pins should have a 0.1-μF to 0.01-μF capacitor placed as close as possible to these pins. Failure to do so may result in the THS7316 outputs ringing or have an oscillation. Additionally, a large capacitor, such as 22 μF to 100 μF, should be placed on the power supply line to minimize interference with 50/60 Hz line frequencies.

INPUT VOLTAGE

The THS7316 input range allows for an input signal range from –0.3 V to about ($V_{S+} - 1.5$ V). But, due to the internal fixed gain of 2 V/V (6 dB) and the internal level shift of nominally 140-mV, the output is generally the limiting factor for the allowable linear input range. For example, with a 5-V supply, the linear input range is from –0.3 V to 3.5 V. However, due to the gain and level shift, the linear output range limits the allowable linear input range to be from about –0.1 V to 2.3 V.

INPUT OVERVOLTAGE PROTECTION

The THS7316 is built using a high-speed complementary bipolar and CMOS process. The internal junction breakdown voltages are low for these small geometry devices. These breakdowns are reflected in the *Absolute Maximum Ratings* table. All input and output device pins are protected with internal ESD protection diodes to the power supplies, as shown in [Figure 26](#).

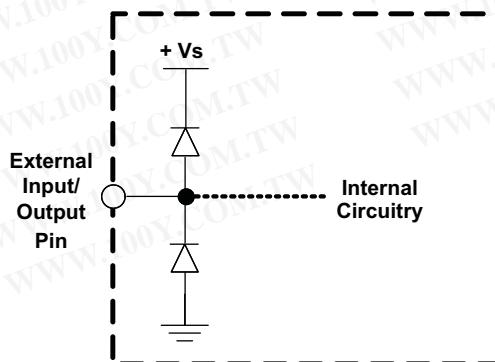

Figure 26. Internal ESD Protection

APPLICATION INFORMATION (continued)

These diodes provide moderate protection to input overdrive voltages above and below the supplies as well. The protection diodes can typically support 30-mA of continuous current when overdriven.

TYPICAL CONFIGURATION and VIDEO TERMINOLOGY

A typical application circuit using the THS7316 as a video buffer is shown in Figure 27. It shows a DAC (or encoder such as the THS8200) driving the three input channels of the THS7316. Although these channels show HDTV Y'P'B'P'R (sometimes labeled Y'C'B'C'R) signals of a 720p or 1080i system, they can also be G'B'R' (R'G'B') signals or other variations.

Note that the Y' term is used for the luma channels throughout this document rather than the more common luminance (Y) term. The reason is to account for the definition of luminance as stipulated by the CIE – International Commission on Illumination. Video departs from true luminance since a nonlinear term, gamma, is added to the true RGB signals to form R'G'B' signals. These R'G'B' signals are then used to mathematically create luma (Y'). Thus luminance (Y) is not maintained providing a difference in terminology.

This rationale is also used for the chroma (C') term. Chroma is derived from the non-linear R'G'B' terms and thus it is nonlinear. Chrominance (C) is derived from linear RGB giving the difference between chroma (C') and chrominance (C). The color difference signals (P'B' / P'R' / U' / V') are also referenced this way to denote the nonlinear (gamma corrected) signals.

R'G'B' (commonly mislabeled RGB) is also called G'B'R' (again commonly mislabeled as GBR) in professional video systems. The SMPTE component standard stipulates that the luma information is placed on the first channel, the blue color difference is placed on the second channel, and the red color difference signal is placed on the third channel. This is consistent with the Y'P'B'P'R nomenclature. Because the luma channel (Y') carries the sync information and the green channel (G') also carries the sync information, it makes logical sense that G' be placed first in the system. Since the blue color difference channel (P'B) is next and the red color difference channel (P'R) is last, then it also makes logical sense to place the B' signal on the second channel and the R' signal on the third channel respectfully. Thus hardware compatibility is better achieved when using G'B'R' rather than R'G'B'. Note that for many G'B'R' systems sync is embedded on all three channels, but may not always be the case in all systems.

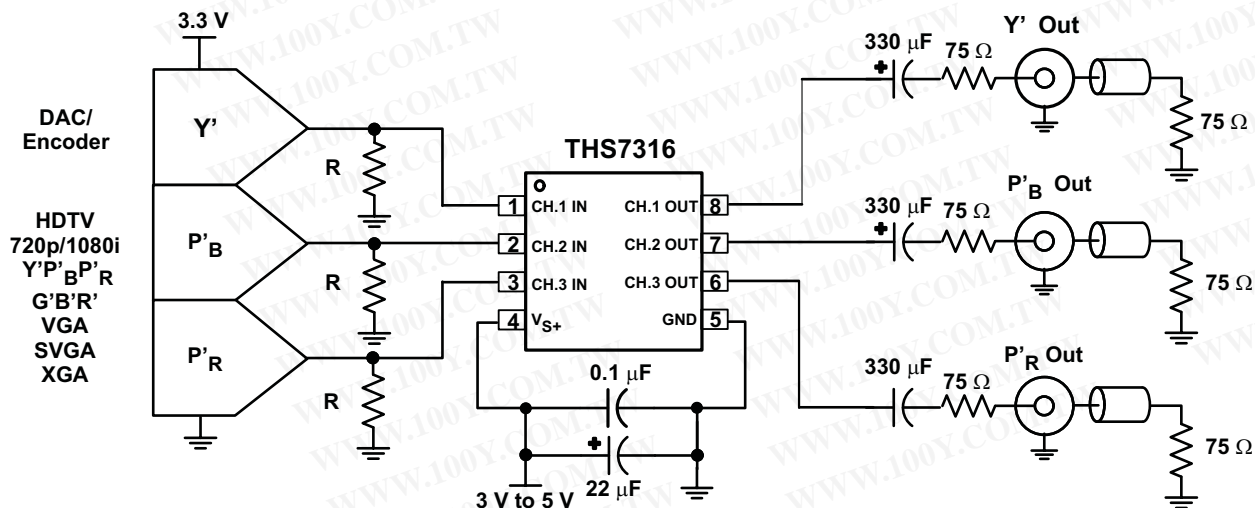

Figure 27. Typical HDTV Y'P'B'/P'R Inputs From DC-Coupled Encoder/DAC With AC-Coupled Line Driving

勝特力材料 886-3-5753170
 勝特力电子(上海) 86-21-54151736
 勝特力电子(深圳) 86-755-83298787
 Http://www.100y.com.tw

APPLICATION INFORMATION (continued)

INPUT MODE OF OPERATION – DC

The inputs to the THS7316 allows for both ac-coupled and dc-coupled inputs. Many DACs or Video Encoders can be dc connected to the THS7316. One of the drawbacks to dc coupling is when 0-V is applied to the input. Although the input of the THS7316 allows for a 0-V input signal with no issues, the output swing of a traditional amplifier cannot yield a 0-V signal resulting in possible clipping. This is true for any single-supply amplifier due to the limitations of the output transistors. Both CMOS and bipolar transistors cannot go to 0-V while sinking current. This trait of a transistor is also the same reason why the highest output voltage is always less than the power supply voltage when sourcing current.

This output clipping can reduce the sync amplitudes (both horizontal and vertical sync amplitudes) on the video signal. A problem occurs if the receiver of this video signal uses an AGC loop to account for losses in the transmission line. Some video AGC circuits derive gain from the horizontal sync amplitude. If clipping occurs on the sync amplitude, then the AGC circuit can increase the gain too much – resulting in too much amplitude gain correction. This may result in a picture with an overly bright display with too much color saturation.

It is good engineering design practice to ensure saturation/clipping does not take place. Transistors always take a finite amount of time to come out of saturation. This saturation could possibly result in timing delays or other aberrations on the signals.

To eliminate saturation/clipping problems, the THS7316 has a dc + 140-mV input shift feature. This feature takes the input voltage and adds an internal +140-mV shift to the signal. Since the THS7316 also has a gain of 6 dB (2 V/V), the resulting output with a 0-V applied input signal is about 280-mV. The THS7316 rail-to-rail output stage can create this output level while connected to a typical video load. This ensures that no saturation / clipping of the sync signals occur. This is a constant shift regardless of the input signal. For example, if a 1-V input is applied, the output is at 2.28-V.

Because the internal gain is fixed at 6 dB, the gain dictates what the allowable linear input voltage range can be without clipping concerns. For example, if the power supply is set to 3-V, the maximum output is about 2.9-V while driving a significant amount of current. Thus, to avoid clipping, the allowable input is $((2.9 \text{ V} / 2) - 0.14 \text{ V}) = 1.31 \text{ V}$. This is true for up to the maximum recommended 5-V power supply that allows about a $((4.9 \text{ V} / 2) - 0.14 \text{ V}) = 2.31 \text{ V}$ input range while avoiding clipping on the output.

The input impedance of the THS7316 in this mode of operation is dictated by the internal 800-k Ω pull-down resistor. This is shown in Figure 28. Note that the internal voltage shift does not appear at the input pin, only the output pin.

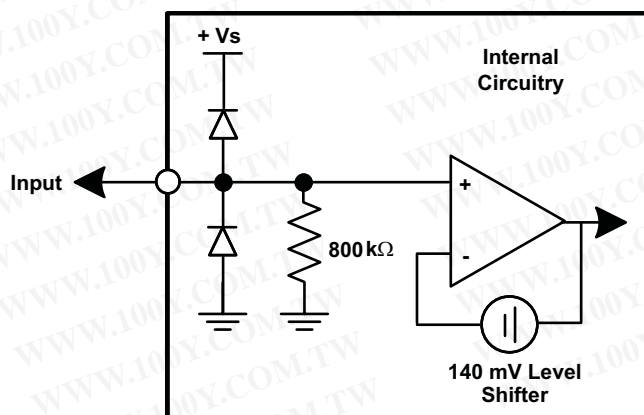

Figure 28. Equivalent DC Input Mode Circuit

APPLICATION INFORMATION (continued)

INPUT MODE OF OPERATION – AC SYNC TIP CLAMP

Some video DACs or encoders are not referenced to ground but rather to the positive power supply. These DACs typically only sink current rather than the more traditional current sourcing DAC where the resistor is referenced to ground. The resulting video signals can be too high of a voltage for a dc-coupled video buffer to function properly. To account for this scenario the THS7316 incorporates a sync-tip clamp circuit. This function requires a capacitor (nominally 0.1 μF) to be in series with the input. Note that while the term sync-tip-clamp is used throughout this document, it should be noted that the THS7316 is better termed as a dc-restoration circuit based on how this function is performed. This circuit is an active clamp circuit and not a passive diode clamp function.

The input to the THS7316 has an internal control loop which sets the lowest input applied voltage to clamp at ground (0-V). By setting the reference at 0-V, the THS7316 allows a dc-coupled input to also function. Hence, the STC is considered transparent since it does not operate unless the input signal goes below ground. The signal then goes through the same 140-mV level shifter resulting in an output voltage low level of 280-mV. If the input signal tries to go below the 0-V, the internal control loop of the THS7316 will source up to 3-mA of current to increase the input voltage level on the THS7316 input side of the coupling capacitor. As soon as the voltage goes above the 0-V level, the loop stops sourcing current and becomes high impedance.

One of the concerns about the sync-tip-clamp level is how the clamp reacts to a sync edge that has overshoot—common in VCR signals or reflections found in poor PCB layouts. Ideally the STC should not react to the overshoot voltage of the input signal. Otherwise, this could result in clipping on the rest of the video signal as it may raise the bias voltage too much.

To help minimize this input signal overshoot problem, the control loop in the THS7316 has an internal low-pass filter as shown in Figure 29. This filter reduces the response time of the STC circuit. This delay is a function of how far the voltage is below ground, but in general it is about a 80-ns delay. The effect of this filter is to slow down the response of the control loop so as not to clamp on the input overshoot voltage, but rather the flat portion of the sync signal.

As a result of this delay, the sync may have an apparent voltage shift. The amount of shift is dependant upon the amount of droop in the signal as dictated by the input capacitor and the STC current flow. Because the sync is primarily for timing purposes with syncing occurring on the edge of the sync signal, this shift is transparent in most systems.

While this feature may not fully eliminate overshoot issues on the input signal for excessive overshoot and/or ringing, the STC system should help minimize improper clamping levels. As an additional method to help minimize this issue, an external capacitor (ex: 10 pF to 47 pF) to ground in parallel with the external termination resistors can help filter overshoot problems.

It should be noted that this STC system is dynamic and does not rely upon timing in any way. It only depends on the voltage appearing at the input pin at any given point in time. The STC filtering helps minimize level shift problems associated with switching noises or very short spikes on the signal line. This helps ensure a very robust STC system.

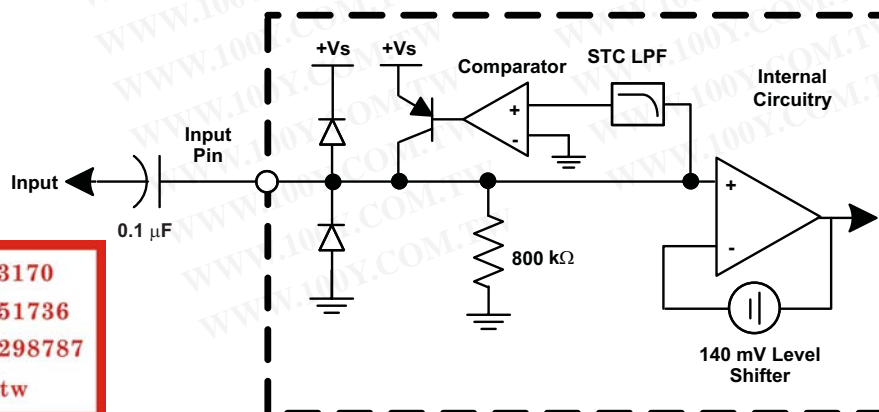

Figure 29. Equivalent AC Sync Tip Clamp Input Circuit

勝特力材料 886-3-5753170
 勝特力电子(上海) 86-21-54151736
 勝特力电子(深圳) 86-755-83298787
[Http://www.100y.com.tw](http://www.100y.com.tw)

APPLICATION INFORMATION (continued)

When the AC Sync-Tip-Clamp (STC) operation is used, there must also be some finite amount of discharge bias current. As previously described, if the input signal goes below the 0-V clamp level, the internal loop of the THS7316 will source current to increase the voltage appearing at the input pin. As the difference between the signal level and the 0-V reference level increases, the amount of source current increases proportionally—supplying up to 3-mA of current. Thus the time to re-establish the proper STC voltage can be fast. If the difference is small, then the source current is also small to account for minor voltage droop.

But, what happens if the input signal goes above the 0-V input level? The problem is the video signal is always above this level, and must not be altered in any way. But if the Sync level of the input signal is above this 0-V level, then the internal discharge (sink) current will discharge the ac-coupled bias signal to the proper 0-V level.

This discharge current must not be large enough to alter the video signal appreciably, or picture quality issues may arise. This is often seen by looking at the tilt (aka droop) of a constant luma signal being applied and looking at the resulting output level. The associated change in luma level from the beginning of the video line to the end of the video line is the amount of line tilt (droop).

If the discharge current is small, the amount of tilt is low which is good. But, the amount of time for the system to capture the sync signal could be too long. This is also termed hum rejection. Hum arises from the ac line voltage frequency of 50-Hz or 60-Hz. The value of the discharge current and the ac-coupling capacitor combine to dictate the hum rejection and the amount of line tilt.

To allow for both dc-coupling and ac-coupling in the same part, the THS7316 incorporates an 800-k Ω resistor to ground. Although a true constant current sink is preferred over a resistor, there are significant issues when the voltage is near ground. This can cause the current sink transistor to saturate and cause potential problems with the signal. This resistor is large enough as to not impact a dc-coupled DAC termination. For discharging an ac-coupled source, Ohm's Law is used. If the video signal is 1 V, then there is $1 \text{ V} / 800 \text{ k}\Omega = 1.25\text{-}\mu\text{A}$ of discharge current. If more hum rejection is desired or there is a loss of sync occurring, then decrease the 0.1- μF input coupling capacitor. A decrease from 0.1 μF to 0.047 μF increases the hum rejection by a factor of 2.1. Alternatively an external pull-down resistor to ground may be added which decreases the overall resistance, and ultimately increases the discharge current.

To ensure proper stability of the AC STC control loop, the source impedance must be less than 1-k Ω with the input capacitor in place. Otherwise, there is a possibility of the control loop to ring and this ringing may appear on the output of the THS7316. Because most DACs or encoders use resistors to establish the voltage, which are typically less than 300- Ω , then meeting the <1-k Ω requirement is done. But, if the source impedance looking from the THS7316 input perspective is high, then add a 1-k Ω resistor to GND to ensure proper operation of the THS7316.

INPUT MODE OF OPERATION – AC BIAS

Sync tip clamps work well for signals that have horizontal and/or vertical syncs associated with them. But, some video signals do not have a sync embedded within the signal – such as Chroma or the P_B' and P_R' channels of a 480i/480p/576i/576p signal; or the bottom of the sync is not the lowest possible level of the video signal – such as the P_B' and P_R' channels of a 720p and 1080i signal. If ac-coupling of these signals is desired, then a dc bias is required to properly set the dc operating point within the THS7316. This function is easily accomplished with the THS7316 by adding an external pull-up resistor to the positive power supply as shown in [Figure 30](#).

勝特力材料 886-3-5753170
勝特力电子(上海) 86-21-54151736
勝特力电子(深圳) 86-755-83298787
[Http://www.100y.com.tw](http://www.100y.com.tw)

APPLICATION INFORMATION (continued)

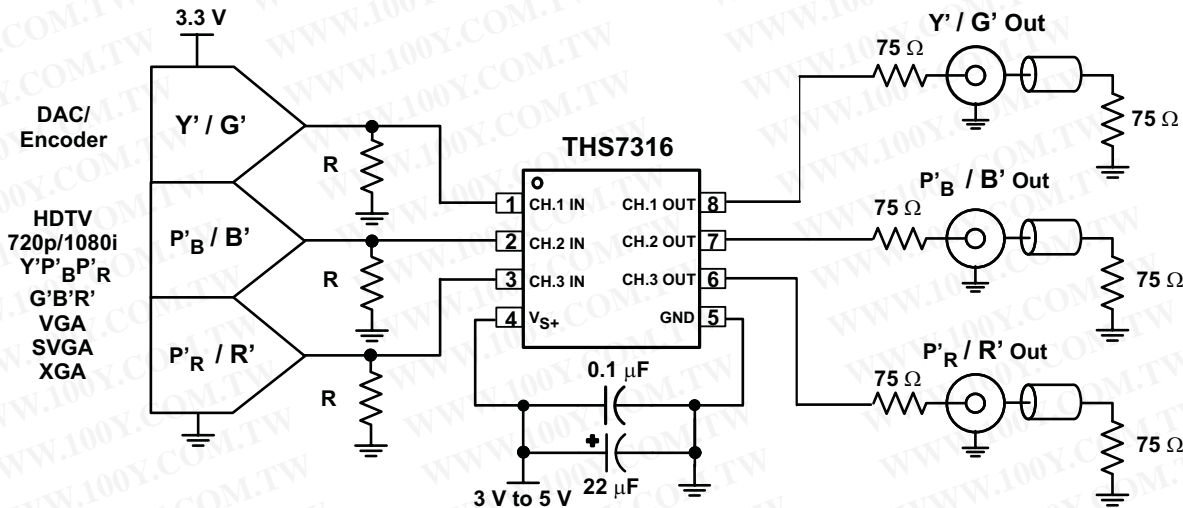

Figure 31. Typical HDTV Y'P'B'R' / G'B'R' System with DC-Coupled Line Driving

One concern of dc-coupling is if the line is terminated to ground. If the ac-bias input configuration is used, the output of the THS7316 will have a dc-bias on the output. With 2 lines terminated to ground, this creates a dc-current path to exist which results in a slightly decreased high output voltage swing and resulting in an increase in power dissipation of the THS7316. While the THS7316 was designed to operate with a junction temperature of up to 125°C, care must be taken to ensure that the junction temperature does not exceed this level or else long term reliability could suffer. Although this configuration only adds less than 10 mW of power dissipation per channel, the overall low power dissipation of the THS7316 design minimizes potential thermal issues even when using the SOIC package at high ambient temperatures.

Another concern of dc coupling is the blanking level voltage of the video signal. The EIA specification dictates that the blanking level shall be 0 V ±1 V. While there is some question as to whether this voltage is at the output of the amplifier or at the receiver, it is generally regarded to be measured at the receiver side of a system as the rest of the specification requirements are given with doubly terminated connections present. With the rail-to-rail output swing capability, combined with the 140-mV input level shift, meeting this requirement is accomplished. Thus, elimination of the large output ac-coupling capacitor can be done while still meeting the EIA specification. This can save significant PCB area and costs.

Note that the THS7316 can drive the line with dc-coupling regardless of the input mode of operation. The only requirement is to make sure the video line has proper termination in series with the output – typically 75-Ω. This helps isolate capacitive loading effects from the THS7316 output. Failure to isolate capacitive loads may result in instabilities with the output buffer potentially causing ringing or oscillations to appear. The stray capacitance appearing directly at the THS7316 output pins should be kept below 20-pF.

OUTPUT MODE OF OPERATION – AC COUPLED

The most common method of coupling the video signal to the line is with the use of a large capacitor. This capacitor is typically between 220-μF and 1000-μF, although 330-μF is common. This value of this capacitor must be this large to minimize the line tilt (droop) and/or field tilt associated with ac-coupling as described previously in this document. AC-coupling is done for several reasons, but the most common reason is to ensure full inter-operability with the receiving video system. This ensures that regardless of the reference dc voltage used on the transmit side, the receive side will re-establish the dc reference voltage to its own requirements, and meets EIA specifications.

Like the dc-output mode of operation, each line should have a 75-Ω source termination resistor in series with the ac-coupling capacitor. If 2 lines are to be driven, it is best to have each line use its own capacitor and resistor rather than sharing these components as shown in Figure 32. This helps ensure line-to-line dc isolation and the potential problems as stipulated previously. Using a single 1000-μF capacitor for 2-lines can be done, but there is a chance for interference to be created between the two receivers.

APPLICATION INFORMATION (continued)

Due to the edge rates and frequencies of operation, it is recommended – but not required – to place a 0.1- μF to 0.01- μF capacitor in parallel with the large 220- μF to 1000- μF capacitor. These large value capacitors are most commonly aluminum electrolytic. These capacitors have significantly large ESR (equivalent series resistance), and their impedance at high frequencies is large due to the associated inductances involved with the leads and construction. The small 0.1- μF to 0.01- μF capacitors help pass these high frequency (>1 MHz) signals with much lower impedance than the large capacitors.

Although it is common to use the same capacitor values for all the video lines, the frequency bandwidth of the chroma signal in a S-Video system are not required to go as low – or as high of a frequency – as the luma channels. Thus the capacitor values of the chroma line(s) can be smaller – such as 0.1- μF .

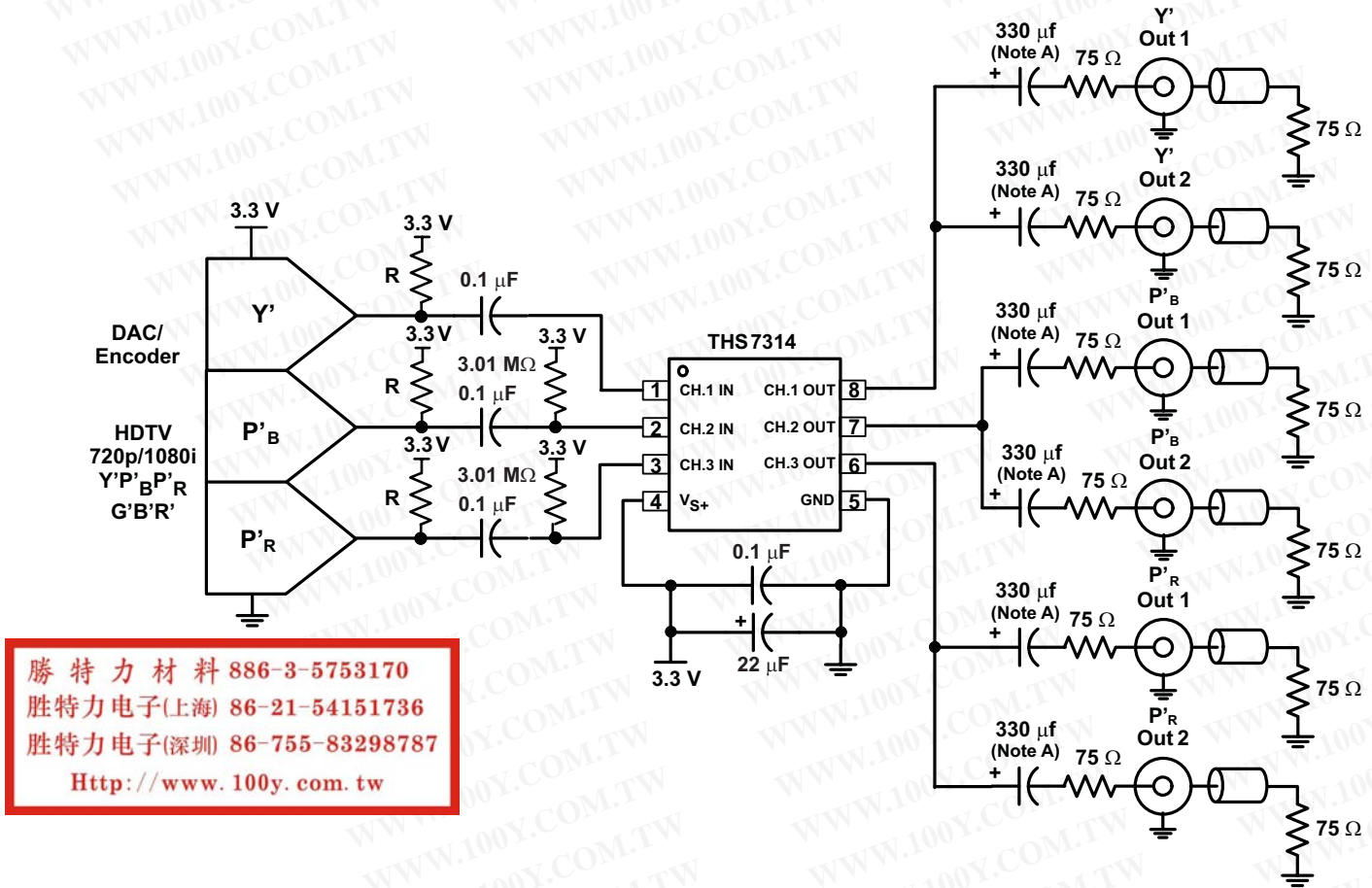

勝特力材料 886-3-5753170
 勝特力电子(上海) 86-21-54151736
 勝特力电子(深圳) 86-755-83298787
[Http://www.100y.com.tw](http://www.100y.com.tw)

- A. Due to the high frequency content of the video signal, it is recommended, but not required, to add a 0.1- μF or 0.01- μF capacitor in parallel with these large capacitors.
- B. Current sinking DAC / Encoder shown. See the application notes.

Figure 32. Typical 480i/576i Y'P'B'P'R AC-Input System Driving 2 AC-Coupled Video Lines

APPLICATION INFORMATION (continued)

LOW PASS FILTER

Each channel of the THS7316 incorporates a 5th-Order Low Pass Filter. These video reconstruction filters minimize DAC images from being passed onto the video receiver. Depending on the receiver design, failure to eliminate these DAC images can cause picture quality problems due to aliasing of the ADC. Another benefit of the filter is to smooth out aberrations in the signal which some DACs can have if their own internal filtering is not good. This helps with picture quality and helps insure the signal meets video bandwidth requirements.

Each filter in the THS7316 is associated with a Butterworth characteristic. The benefit of the Butterworth response is that the frequency response is flat with a relatively steep initial attenuation at the corner frequency. The problem is that the group delay rises near the corner frequency. Group delay is defined as the change in phase (radians/second) divided by a change in frequency. An increase in group delay corresponds to a time domain pulse response that has overshoot and some possible ringing associated with the overshoot.

The use of other type of filters, such as elliptic or chebyshev, are not recommended for video applications due to their very large group delay variations near the corner frequency resulting in significant overshoot and ringing. While these elliptic or chebyshev filters may help meet the video standard specifications with respect to amplitude attenuation, their group delay is beyond the standard specifications. Coupled with the fact that video can go from a white pixel to a black pixel over and over again, ringing can occur. Ringing typically causes a display to have *ghosting* or *fuzziness* appear on the edges of a sharp transition. However, a Bessel filter has an ideal group delay response, but the rate of attenuation is typically too low for acceptable image rejection. Thus the Butterworth filter is a respectable compromise for both attenuation and group delay.

The THS7316 filters have a nominal corner (-3dB) frequency at 36-MHz and a -1 dB passband typically at 31-MHz. This 36-MHz filter is ideal for High Definition (HD) 720p and 1080i signals. For systems that oversample significantly, the THS7316 can also be useful for Standard Definition (SD) NTSC and PAL signals such as 480i/576i Y'P_BP_R, Y'U'V', and broadcast G'B'R' (R'G'B') signals. It can also be useful with Enhanced Definition (ED) signals including 480p/576p Y'P_BP_R, Y'U'V', broadcast G'B'R' (R'G'B') signals, and computer video signals.

The 36-MHz -3dB corner frequency was designed to allow a maximally flat video signal while achieving 30-dB of attenuation at 74.25-MHz – a common sampling frequency between the DAC/ADC 2nd and 3rd Nyquist zones found in many video systems. This is important because any signal appearing around this frequency can appear in the baseband due to aliasing effects of an analog to digital converter found in a receiver. Keep in mind that DAC images do not stop at 74.25 MHz, they continue around the sampling frequencies of 148.5 MHz, 222.75-MHz, 297-MHz, etc. Because of these multiple images that an ADC can fold down into the baseband signal, the low pass filter must also eliminate these higher order images. The THS7316 has over 50-dB attenuation at 148.5-MHz, over 50-dB attenuation at 222.75-MHz, and about 55-dB attenuation at 297-MHz. Attenuation to 1-GHz is at least 36-dB which makes sure that images do not effect the desired video baseband signal.

The 36-MHz filter frequency was chosen to account for process variations in the THS7316. To ensure the required video frequencies are not affected, the filter corner frequency must be high enough to allow component variations. The other consideration is the attenuation must be large enough to ensure the anti-aliasing / reconstruction filtering is enough to meet the system demands. Thus, the filter frequencies were not arbitrarily selected.

勝特力材料 886-3-5753170
勝特力电子(上海) 86-21-54151736
勝特力电子(深圳) 86-755-83298787
[Http://www.100y.com.tw](http://www.100y.com.tw)

APPLICATION INFORMATION (continued)

BENEFITS OVER PASSIVE FILTERING

Two key benefits of using an integrated filter system, such as the THS7316, over a passive system is PCB area and filter variations. The small SOIC-8 package for 3-video channels is much smaller over a passive RLC network, especially a 5-pole passive network. Add in the fact that inductors have at best $\pm 10\%$ tolerances (normally $\pm 15\%$ to $\pm 20\%$ is common) and capacitors typically have $\pm 10\%$ tolerances. Using a Monte Carlo analysis shows that the filter corner frequency (-3 dB), flatness (-1 dB), Q factor (or peaking), and channel-to-channel delay has wide variations. This can lead to potential performance and quality issues in mass-production environments. The THS7316 solves most of these problems by using the corner frequency as essentially the only variable.

One concern about an active filter in an integrated circuit is the variation of the filter characteristics when the ambient temperature and the subsequent die temperature changes. To minimize temperature effects, the THS7316 uses low temperature coefficient resistors and high quality – low temperature coefficient capacitors found in the BiCom-3 process. The filters have been specified by design to account for process variations and temperature variations to maintain proper filter characteristics. This maintains a low channel-to-channel time delay which is required for proper video signal performance.

Another benefit of a THS7316 over a passive RLC filter are the input and output impedances. The input impedance presented to the DAC varies significantly with a passive network and may cause voltage variations over frequency. The THS7316 input impedance is $800\text{-k}\Omega$ and only the 2-pF input capacitance plus the PCB trace capacitance impacting the input impedance. As such, the voltage variation appearing at the DAC output is better controlled with the THS7316.

On the output side of the filter, a passive filter will again have a impedance variation over frequency. The THS7316 is an op-amp which approximates an ideal voltage source. A voltage source is desirable because the output impedance is very low and can source and sink current. To properly match the transmission line characteristic impedance of a video line, a $75\text{-}\Omega$ series resistor is placed on the output. To minimize reflections and to maintain a good return loss, this output impedance must maintain a $75\text{-}\Omega$ impedance. A passive filter impedance variation is not specified while the THS7316 has approximately $0.5\text{-}\Omega$ of output impedance at 10 MHz. Thus, the system is matched better with a THS7316 compared to a passive filter.

One last benefit of the THS7316 over a passive filter is power dissipation. A DAC driving a video line must be able to drive a $37.5\text{-}\Omega$ load - the receiver $75\text{-}\Omega$ resistor and the $75\text{-}\Omega$ impedance matching resistor next to the DAC to maintain the source impedance requirement. This forces the DAC to drive at least 1.25-V peak (100% Saturation CVBS) / $37.5\ \Omega = 33.3\ \text{mA}$. A DAC is a current steering element and this amount of current flows internally to the DAC even if the output is 0-V . Thus, power dissipation in the DAC may be high - especially when 6-channels are being driven. Using the THS7316, with a high input impedance and the capability to drive up to 2-video lines per channel, can reduce the DAC power dissipation significantly. This is because the resistance the DAC is driving can be substantially increased. It is common to set this in a DAC by a current setting resistor on the DAC. Thus, the resistance can be $300\text{-}\Omega$ or more - substantially reducing the current drive demands from the DAC and saving substantial amount of power. For example, a 3.3-V 6-Channel DAC dissipates $660\ \text{mW}$ just for the steering current capability ($6\ \text{ch} \times 33.3\ \text{mA} \times 3.3\ \text{V}$) if it needs to drive $37.5\text{-}\Omega$ load. With a $300\text{-}\Omega$ load, the DAC power dissipation due to current steering current would only be $82.5\ \text{mW}$ ($6\ \text{ch} \times 4.16\ \text{mA} \times 3.3\ \text{V}$).

勝特力材料 886-3-5753170
勝特力电子(上海) 86-21-54151736
勝特力电子(深圳) 86-755-83298787
[Http://www.100y.com.tw](http://www.100y.com.tw)

EVALUATION MODULE

To evaluate the THS7316, an evaluation module (EVM) is available. This allows for testing of the THS7316 in many different systems. Inputs and outputs include RCA connectors for consumer grade interconnections, or BNC connectors for higher level lab grade connections. Several unpopulated component pads are found on the EVM to allow for different input and output configurations as dictated by the user.

Figure 33 shows the schematic of the THS7316 EVM. Figure 34 and Figure 35 shows the top layer and bottom layer of the EVM which incorporates standard high-speed layout practices. The bill of materials is shown in Table 1 as supplied from Texas Instruments.

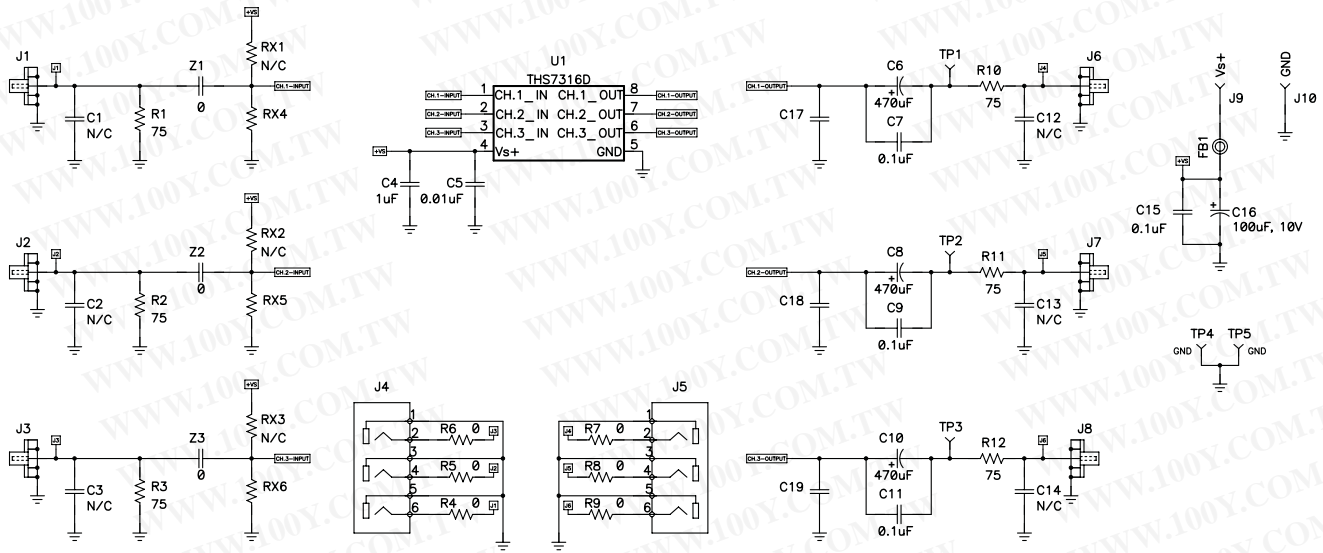

Figure 33. THS7316D EVM

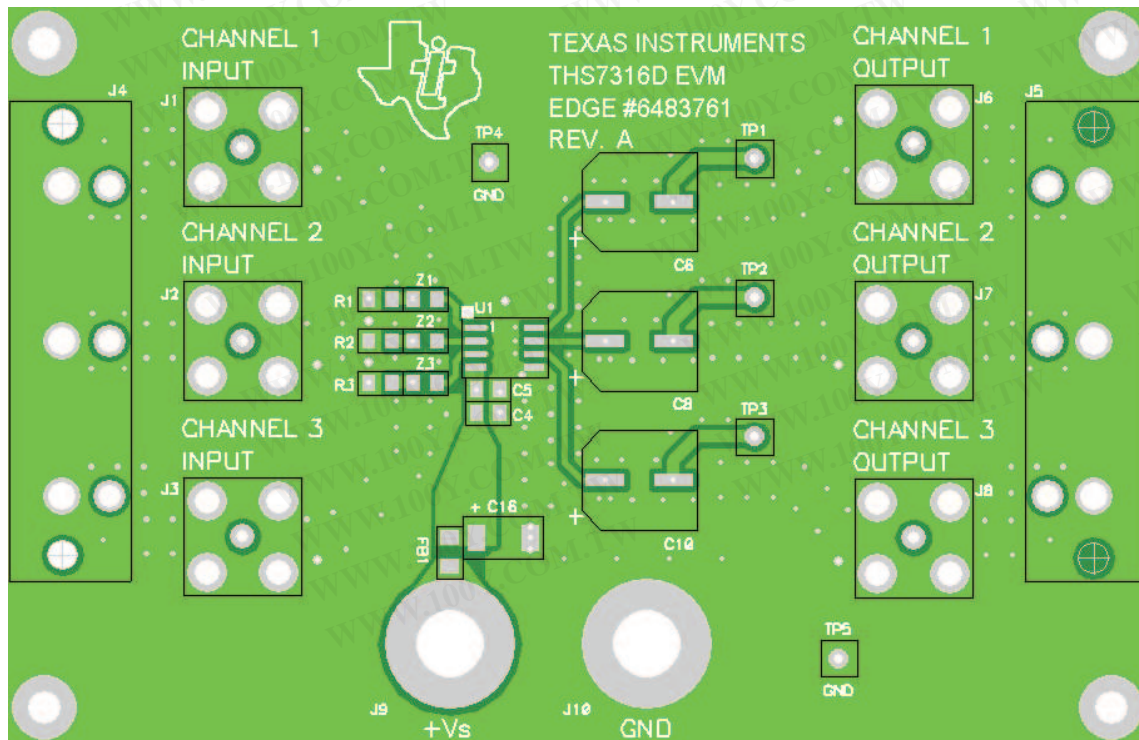

Figure 34. Top View

THS7316

SLOS521-MARCH 2007

EVALUATION MODULE (continued)

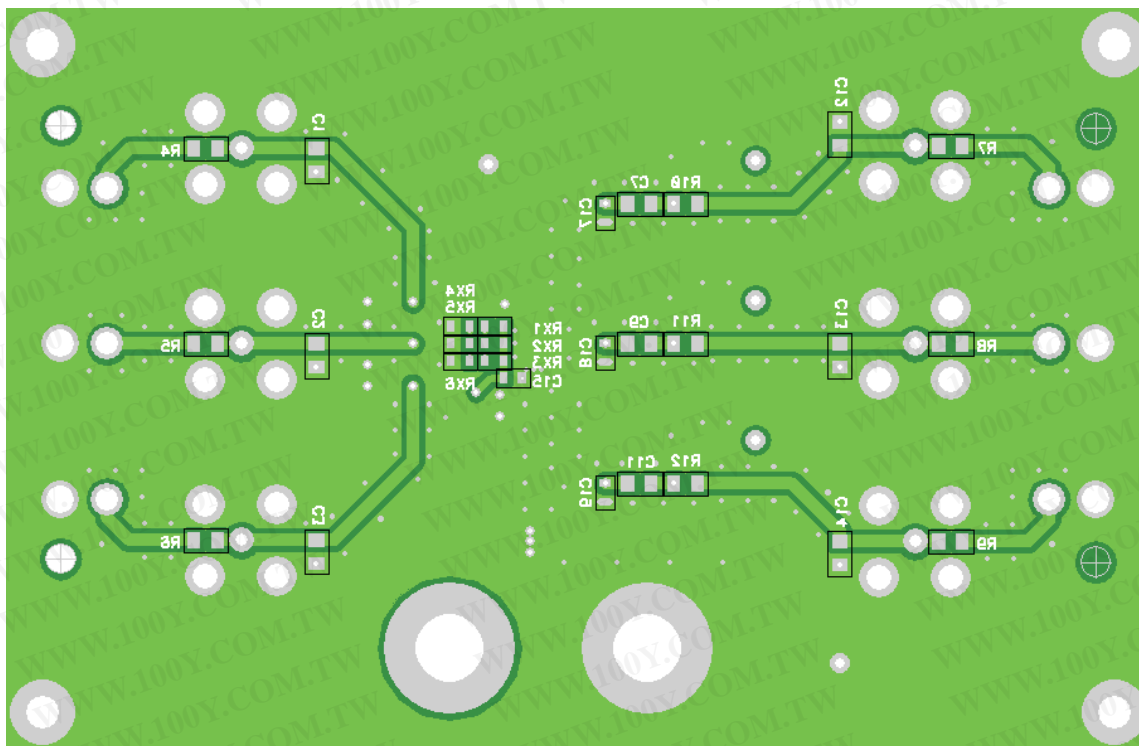

Figure 35. Bottom View

Bill of Materials

Table 1. THS7316D EVM

ITEM	REF DES	QTY	DESCRIPTION	SMD SIZE	MANUFACTURER PART NUMBER	DISTRIBUTOR PART NUMBER
1	FB1	1	BEAD, FERRITE, 2.5A, 330 OHM	0805	(TDK) MPZ2012S331A	(DIGI-KEY) 445-1569-1-ND
2	C16	1	CAP, 100 μ F, TAN, 10V, 10%, LO ESR	C	(AVX) TPSC107K010R0100	(DIGI-KEY) 478-1765-1-ND
3	C17, C18, C19	3	OPEN	0603		
4	C15	1	CAP, 0.1 μ F, CERAMIC, 16V, X7R	0603	(AVX) 0603YC104KAT2A	(GARRETT) 0603YC104KAT2A
5	C1, C2, C3, C12, C13, C14	6	OPEN	0805		
6	C5	1	CAP, 0.01 μ F, CERAMIC, 100V, X7R	0805	(AVX) 08051C103KAT2A	(DIGI-KEY) 478-1358-1-ND
7	C7, C9, C11	3	CAP, 0.1 μ F, CERAMIC, 50V, X7R	0805	(AVX) 08055C104KAT2A	(DIGI-KEY) 478-1395-1-ND
8	C4	1	CAP, 1 μ F, CERAMIC, 16V, X7R	0805	(TDK) C2012X7R1C105K	(DIGI-KEY) 445-1358-1-ND
9	C6, C8, C10	3	CAP, ALUM, 470 μ F, 10V, 20%	F	(CORNELL) AFK477M10F24B	(NEWARK) 97C7597
10	RX1, RX2, RX3, RX4, RX5, RX6	6	OPEN	0603		
11	R4, R5, R6, R7, R8, R9, Z1, Z2, Z3	9	RESISTOR, 0 OHM	0805	(ROHM) MCR10EZJH000	(DIGI-KEY) RHM0.0ACT-ND
12	R1, R2, R3, R10, R11, R12	6	RESISTOR, 75 OHM, 1/8W, 1%	0805	(ROHM) MCR10EZHF75.0	(DIGI-KEY) RHM75.0CCT-ND

EVALUATION MODULE (continued)
Table 1. THS7316D EVM (continued)

ITEM	REF DES	QTY	DESCRIPTION	SMD SIZE	MANUFACTURER PART NUMBER	DISTRIBUTOR PART NUMBER
13	J9, J10	2	JACK, BANANA RECEPTANCE, 0.25" DIA. HOLE		(SPC) 813	(NEWARK) 39N867
14	J1, J2, J3, J6, J7, J8	6	CONNECTOR, BNC, JACK, 75 OHM		(AMPHENOL) 31-5329-72RFX	(NEWARK) 93F7554
15	J4, J5	2	CONNECTOR, RCA, JACK, R/A		(CUI) RCJ-32265	(DIGI-KEY) CP-1446-ND
16	TP1, TP2, TP3	3	TEST POINT, RED		(KEYSTONE) 5000	(DIGI-KEY) 5000K-ND
17	TP4, TP5	2	TEST POINT, BLACK		(KEYSTONE) 5001	(DIGI-KEY) 5001K-ND
18	U1	1	IC, THS7316	D	(TI) THS7316D	
19		4	STANDOFF, 4-40 HEX, 0.625" LENGTH		(KEYSTONE) 1808	(NEWARK) 89F1934
20		4	SCREW, PHILLIPS, 4-40, .250"		(BF) PMS 440 0031 PH	(DIGI-KEY) H343-ND
21		1	BOARD, PRINTED CIRCUIT		EDGE # 6483761 REV. A	

EVALUATION BOARD/KIT IMPORTANT NOTICE

Texas Instruments (TI) provides the enclosed product(s) under the following conditions:

This evaluation board/kit is intended for use for **ENGINEERING DEVELOPMENT, DEMONSTRATION, OR EVALUATION PURPOSES ONLY** and is not considered by TI to be a finished end-product fit for general consumer use. Persons handling the product(s) must have electronics training and observe good engineering practice standards. As such, the goods being provided are not intended to be complete in terms of required design-, marketing-, and/or manufacturing-related protective considerations, including product safety and environmental measures typically found in end products that incorporate such semiconductor components or circuit boards. This evaluation board/kit does not fall within the scope of the European Union directives regarding electromagnetic compatibility, restricted substances (RoHS), recycling (WEEE), FCC, CE or UL, and therefore may not meet the technical requirements of these directives or other related directives.

Should this evaluation board/kit not meet the specifications indicated in the User's Guide, the board/kit may be returned within 30 days from the date of delivery for a full refund. **THE FOREGOING WARRANTY IS THE EXCLUSIVE WARRANTY MADE BY SELLER TO BUYER AND IS IN LIEU OF ALL OTHER WARRANTIES, EXPRESSED, IMPLIED, OR STATUTORY, INCLUDING ANY WARRANTY OF MERCHANTABILITY OR FITNESS FOR ANY PARTICULAR PURPOSE.**

The user assumes all responsibility and liability for proper and safe handling of the goods. Further, the user indemnifies TI from all claims arising from the handling or use of the goods. Due to the open construction of the product, it is the user's responsibility to take any and all appropriate precautions with regard to electrostatic discharge.

EXCEPT TO THE EXTENT OF THE INDEMNITY SET FORTH ABOVE, NEITHER PARTY SHALL BE LIABLE TO THE OTHER FOR ANY INDIRECT, SPECIAL, INCIDENTAL, OR CONSEQUENTIAL DAMAGES.

TI currently deals with a variety of customers for products, and therefore our arrangement with the user **is not exclusive.**

TI assumes **no liability for applications assistance, customer product design, software performance, or infringement of patents or services described herein.**

Please read the User's Guide and, specifically, the Warnings and Restrictions notice in the User's Guide prior to handling the product. This notice contains important safety information about temperatures and voltages. For additional information on TI's environmental and/or safety programs, please contact the TI application engineer or visit www.ti.com/esh.

No license is granted under any patent right or other intellectual property right of TI covering or relating to any machine, process, or combination in which such TI products or services might be or are used.

FCC Warning

This evaluation board/kit is intended for use for **ENGINEERING DEVELOPMENT, DEMONSTRATION, OR EVALUATION PURPOSES ONLY** and is not considered by TI to be a finished end-product fit for general consumer use. It generates, uses, and can radiate radio frequency energy and has not been tested for compliance with the limits of computing devices pursuant to part 15 of FCC rules, which are designed to provide reasonable protection against radio frequency interference. Operation of this equipment in other environments may cause interference with radio communications, in which case the user at his own expense will be required to take whatever measures may be required to correct this interference.

Mailing Address: Texas Instruments, Post Office Box 655303, Dallas, Texas 75265
Copyright © 2007, Texas Instruments Incorporated

EVM WARNINGS AND RESTRICTIONS

It is important to operate this EVM within the input voltage range of 2.85 V to 5.5 V single supply and the output voltage range of 0 V to 5.5 V.

Exceeding the specified input range may cause unexpected operation and/or irreversible damage to the EVM. If there are questions concerning the input range, please contact a TI field representative prior to connecting the input power.

Applying loads outside of the specified output range may result in unintended operation and/or possible permanent damage to the EVM. Please consult the EVM User's Guide prior to connecting any load to the EVM output. If there is uncertainty as to the load specification, please contact a TI field representative.

During normal operation, some circuit components may have case temperatures greater than 85°C. The EVM is designed to operate properly with certain components above 85°C as long as the input and output ranges are maintained. These components include but are not limited to linear regulators, switching transistors, pass transistors, and current sense resistors. These types of devices can be identified using the EVM schematic located in the EVM User's Guide. When placing measurement probes near these devices during operation, please be aware that these devices may be very warm to the touch.

Mailing Address: Texas Instruments, Post Office Box 655303, Dallas, Texas 75265
Copyright © 2007, Texas Instruments Incorporated

勝特力材料 886-3-5753170
勝特力电子(上海) 86-21-54151736
勝特力电子(深圳) 86-755-83298787
[Http://www.100y.com.tw](http://www.100y.com.tw)

PACKAGING INFORMATION

Orderable Device	Status ⁽¹⁾	Package Type	Package Drawing	Pins	Package Qty	Eco Plan ⁽²⁾	Lead/Ball Finish	MSL Peak Temp ⁽³⁾
THS7316D	ACTIVE	SOIC	D	8	75	Green (RoHS & no Sb/Br)	CU NIPDAU	Level-2-260C-1 YEAR
THS7316DG4	ACTIVE	SOIC	D	8	75	Green (RoHS & no Sb/Br)	CU NIPDAU	Level-2-260C-1 YEAR
THS7316DR	ACTIVE	SOIC	D	8	2500	Green (RoHS & no Sb/Br)	CU NIPDAU	Level-2-260C-1 YEAR
THS7316DRG4	ACTIVE	SOIC	D	8	2500	Green (RoHS & no Sb/Br)	CU NIPDAU	Level-2-260C-1 YEAR

⁽¹⁾ The marketing status values are defined as follows:

ACTIVE: Product device recommended for new designs.

LIFEBUY: TI has announced that the device will be discontinued, and a lifetime-buy period is in effect.

NRND: Not recommended for new designs. Device is in production to support existing customers, but TI does not recommend using this part in a new design.

PREVIEW: Device has been announced but is not in production. Samples may or may not be available.

OBSOLETE: TI has discontinued the production of the device.

⁽²⁾ Eco Plan - The planned eco-friendly classification: Pb-Free (RoHS), Pb-Free (RoHS Exempt), or Green (RoHS & no Sb/Br) - please check <http://www.ti.com/productcontent> for the latest availability information and additional product content details.

TBD: The Pb-Free/Green conversion plan has not been defined.

Pb-Free (RoHS): TI's terms "Lead-Free" or "Pb-Free" mean semiconductor products that are compatible with the current RoHS requirements for all 6 substances, including the requirement that lead not exceed 0.1% by weight in homogeneous materials. Where designed to be soldered at high temperatures, TI Pb-Free products are suitable for use in specified lead-free processes.

Pb-Free (RoHS Exempt): This component has a RoHS exemption for either 1) lead-based flip-chip solder bumps used between the die and package, or 2) lead-based die adhesive used between the die and leadframe. The component is otherwise considered Pb-Free (RoHS compatible) as defined above.

Green (RoHS & no Sb/Br): TI defines "Green" to mean Pb-Free (RoHS compatible), and free of Bromine (Br) and Antimony (Sb) based flame retardants (Br or Sb do not exceed 0.1% by weight in homogeneous material)

⁽³⁾ MSL, Peak Temp. -- The Moisture Sensitivity Level rating according to the JEDEC industry standard classifications, and peak solder temperature.

Important Information and Disclaimer:The information provided on this page represents TI's knowledge and belief as of the date that it is provided. TI bases its knowledge and belief on information provided by third parties, and makes no representation or warranty as to the accuracy of such information. Efforts are underway to better integrate information from third parties. TI has taken and continues to take reasonable steps to provide representative and accurate information but may not have conducted destructive testing or chemical analysis on incoming materials and chemicals. TI and TI suppliers consider certain information to be proprietary, and thus CAS numbers and other limited information may not be available for release.

In no event shall TI's liability arising out of such information exceed the total purchase price of the TI part(s) at issue in this document sold by TI to Customer on an annual basis.

勝特力材料 886-3-5753170
 勝特力电子(上海) 86-21-54151736
 勝特力电子(深圳) 86-755-83298787
[Http://www.100y.com.tw](http://www.100y.com.tw)

TAPE AND REEL INFORMATION

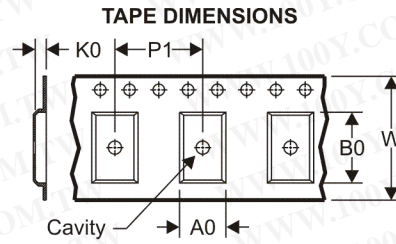
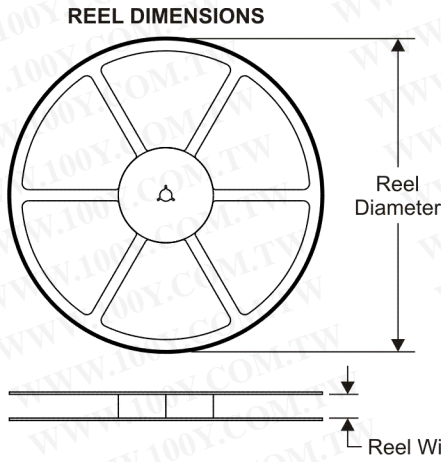

A0	Dimension designed to accommodate the component width
B0	Dimension designed to accommodate the component length
K0	Dimension designed to accommodate the component thickness
W	Overall width of the carrier tape
P1	Pitch between successive cavity centers

QUADRANT ASSIGNMENTS FOR PIN 1 ORIENTATION IN TAPE

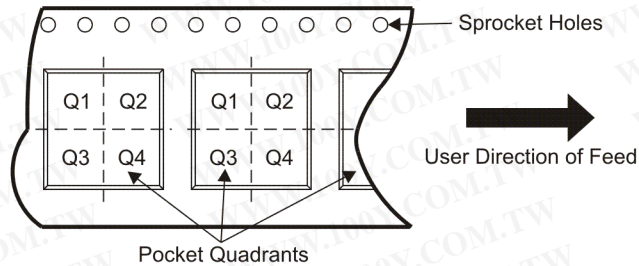

*All dimensions are nominal

Device	Package Type	Package Drawing	Pins	SPQ	Reel Diameter (mm)	Reel Width W1 (mm)	A0 (mm)	B0 (mm)	K0 (mm)	P1 (mm)	W (mm)	Pin1 Quadrant
THS7316DR	SOIC	D	8	2500	330.0	12.4	6.4	5.2	2.1	8.0	12.0	Q1

勝特力材料 886-3-5753170
 勝特力电子(上海) 86-21-54151736
 勝特力电子(深圳) 86-755-83298787
[Http://www.100y.com.tw](http://www.100y.com.tw)

TAPE AND REEL BOX DIMENSIONS

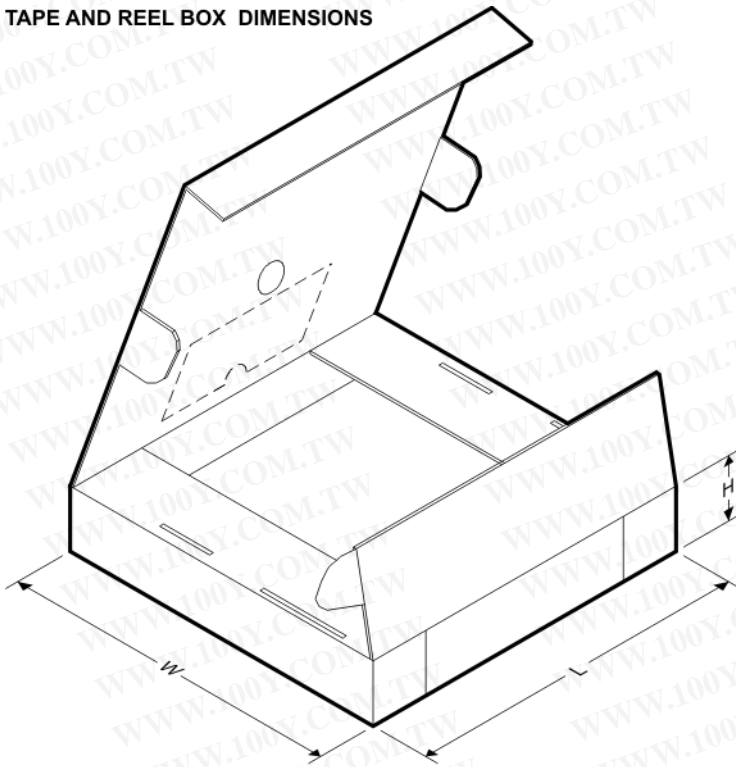

勝特力材料 886-3-5753170
 勝特力电子(上海) 86-21-54151736
 勝特力电子(深圳) 86-755-83298787
 Http://www.100y.com.tw

*All dimensions are nominal

Device	Package Type	Package Drawing	Pins	SPQ	Length (mm)	Width (mm)	Height (mm)
THS7316DR	SOIC	D	8	2500	346.0	346.0	29.0

D (R-PDSO-G8)

PLASTIC SMALL-OUTLINE PACKAGE

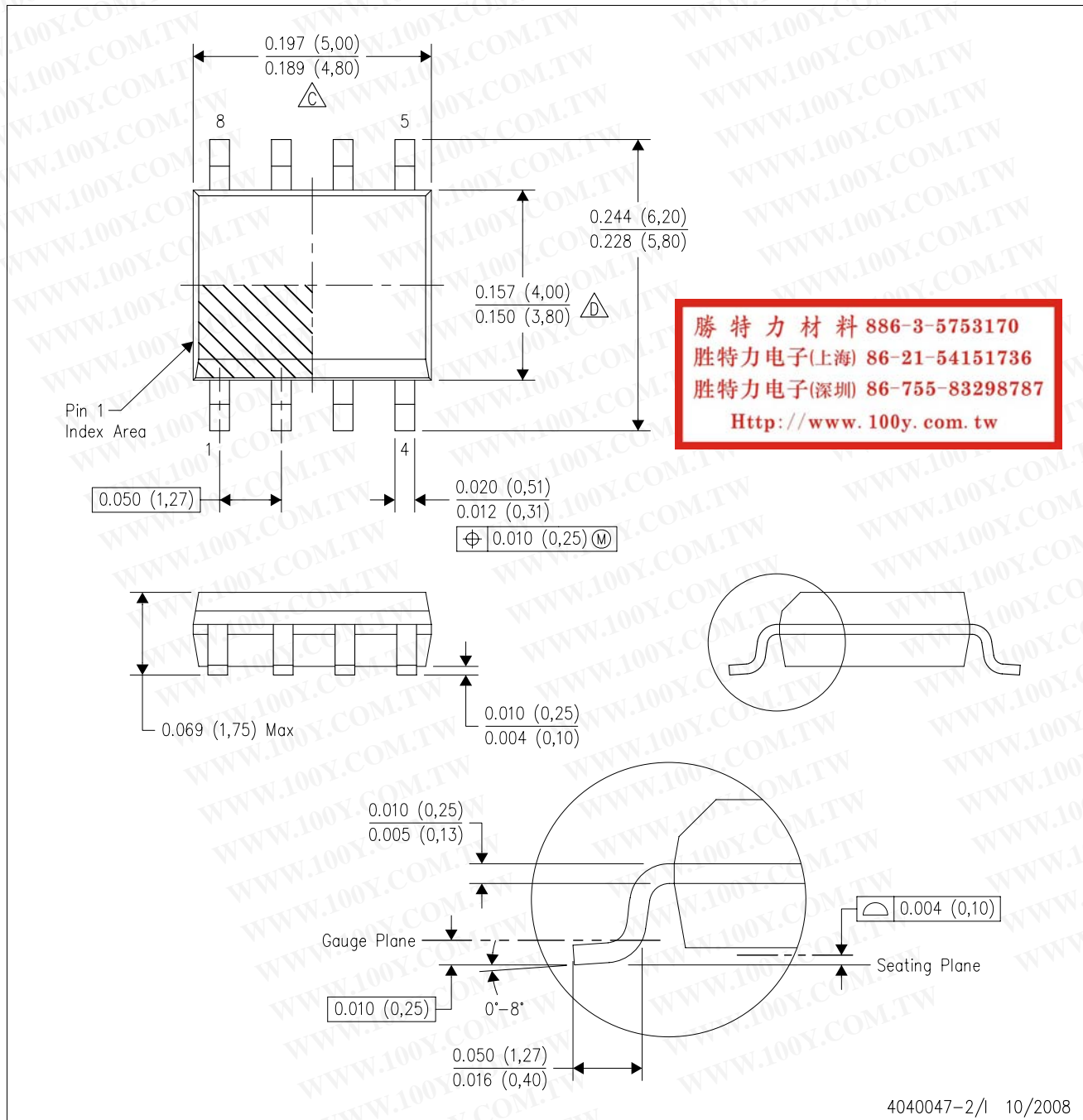

- NOTES:
- A. All linear dimensions are in inches (millimeters).
 - B. This drawing is subject to change without notice.
 - C. Body length does not include mold flash, protrusions, or gate burrs. Mold flash, protrusions, or gate burrs shall not exceed .006 (0,15) per end.
 - D. Body width does not include interlead flash. Interlead flash shall not exceed .017 (0,43) per side.
 - E. Reference JEDEC MS-012 variation AA.

勝特力材料 886-3-5753170
勝特力电子(上海) 86-21-54151736
勝特力电子(深圳) 86-755-83298787
Http://www.100y.com.tw

IMPORTANT NOTICE

Texas Instruments Incorporated and its subsidiaries (TI) reserve the right to make corrections, modifications, enhancements, improvements, and other changes to its products and services at any time and to discontinue any product or service without notice. Customers should obtain the latest relevant information before placing orders and should verify that such information is current and complete. All products are sold subject to TI's terms and conditions of sale supplied at the time of order acknowledgment.

TI warrants performance of its hardware products to the specifications applicable at the time of sale in accordance with TI's standard warranty. Testing and other quality control techniques are used to the extent TI deems necessary to support this warranty. Except where mandated by government requirements, testing of all parameters of each product is not necessarily performed.

TI assumes no liability for applications assistance or customer product design. Customers are responsible for their products and applications using TI components. To minimize the risks associated with customer products and applications, customers should provide adequate design and operating safeguards.

TI does not warrant or represent that any license, either express or implied, is granted under any TI patent right, copyright, mask work right, or other TI intellectual property right relating to any combination, machine, or process in which TI products or services are used. Information published by TI regarding third-party products or services does not constitute a license from TI to use such products or services or a warranty or endorsement thereof. Use of such information may require a license from a third party under the patents or other intellectual property of the third party, or a license from TI under the patents or other intellectual property of TI.

Reproduction of TI information in TI data books or data sheets is permissible only if reproduction is without alteration and is accompanied by all associated warranties, conditions, limitations, and notices. Reproduction of this information with alteration is an unfair and deceptive business practice. TI is not responsible or liable for such altered documentation. Information of third parties may be subject to additional restrictions.

Resale of TI products or services with statements different from or beyond the parameters stated by TI for that product or service voids all express and any implied warranties for the associated TI product or service and is an unfair and deceptive business practice. TI is not responsible or liable for any such statements.

TI products are not authorized for use in safety-critical applications (such as life support) where a failure of the TI product would reasonably be expected to cause severe personal injury or death, unless officers of the parties have executed an agreement specifically governing such use. Buyers represent that they have all necessary expertise in the safety and regulatory ramifications of their applications, and acknowledge and agree that they are solely responsible for all legal, regulatory and safety-related requirements concerning their products and any use of TI products in such safety-critical applications, notwithstanding any applications-related information or support that may be provided by TI. Further, Buyers must fully indemnify TI and its representatives against any damages arising out of the use of TI products in such safety-critical applications.

TI products are neither designed nor intended for use in military/aerospace applications or environments unless the TI products are specifically designated by TI as military-grade or "enhanced plastic." Only products designated by TI as military-grade meet military specifications. Buyers acknowledge and agree that any such use of TI products which TI has not designated as military-grade is solely at the Buyer's risk, and that they are solely responsible for compliance with all legal and regulatory requirements in connection with such use.

TI products are neither designed nor intended for use in automotive applications or environments unless the specific TI products are designated by TI as compliant with ISO/TS 16949 requirements. Buyers acknowledge and agree that, if they use any non-designated products in automotive applications, TI will not be responsible for any failure to meet such requirements.

Following are URLs where you can obtain information on other Texas Instruments products and application solutions:

Products

Amplifiers amplifier.ti.com
Data Converters dataconverter.ti.com
DSP dsp.ti.com
Clocks and Timers www.ti.com/clocks
Interface interface.ti.com
Logic logic.ti.com
Power Mgmt power.ti.com
Microcontrollers microcontroller.ti.com
RFID www.ti-rfid.com
RF/IF and ZigBee® Solutions www.ti.com/lprf

Applications

Audio www.ti.com/audio
Automotive www.ti.com/automotive
Broadband www.ti.com/broadband
Digital Control www.ti.com/digitalcontrol
Medical www.ti.com/medical
Military www.ti.com/military
Optical Networking www.ti.com/opticalnetwork
Security www.ti.com/security
Telephony www.ti.com/telephony
Video & Imaging www.ti.com/video
Wireless www.ti.com/wireless

Mailing Address: Texas Instruments, Post Office Box 655303, Dallas, Texas 75265
Copyright © 2008, Texas Instruments Incorporated