

25mW TRUE CAP FREE STEREO HEADPHONE AMPLIFIER

Description

The PAM8901 / PAM8908 stereo headphone driver is designed for portable equipment where board space is at a premium. The PAM8901 / PAM8908 uses a unique, patent pending architecture to produce a ground-referenced output from a single supply, eliminating the need for large DC-blocking capacitors, saving cost, board space, and component height.

The PAM8901 / PAM8908 delivers up to 25mW per channel into a 16Ω load and has low 0.03% THD+N. A high power-supply rejection ratio (80dB at 1kHz) allows this device to operate from noisy digital supplies without an additional linear regulator.

The PAM8901 / PAM8908 operates from a single supply from 2.5V to 5.5V, has short-circuit and over temperature protection. Shutdown mode reduces supply current to less than 1μA.

Pin Assignments

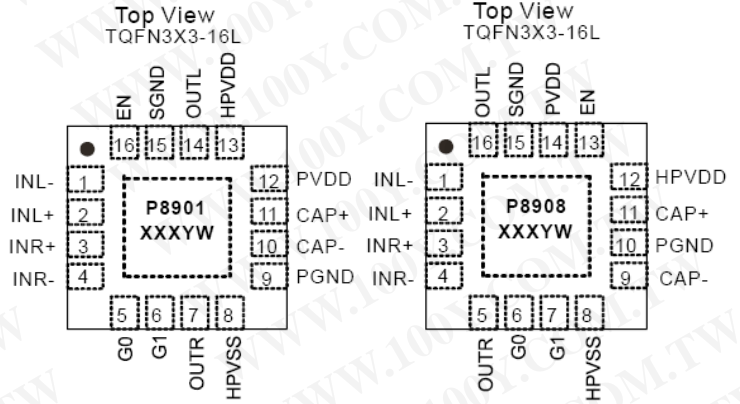

Features

- Patent Pending 3 Phase Power Line Shift Charge Pump Eliminates Need for DC-Blocking Capacitors
- TrueCapFree Architecture, Output Biased at 0V (System Ground)
- Excellent Low Frequency Fidelity
- 80dB PSRR at 1kHz
- Less than 1uA Shutdown current
- Support both Fully differential and Single-Ended Inputs
- Short Circuit and Over Temperature Protection
- Selectable Gain settings: -6dB, 0dB, 3dB and 6dB
- Available in Space Saving Packages: TQFN3x3-16L

Applications

- Smart Phones/Cellular Phones
- Notebook Computers
- Portable DVD Player
- Personal Digital Assistants (PDAs)
- Electronic Dictionaries
- Digital Still Cameras
- Portable Gaming

Typical Applications Circuit

Typical Application Configuration with Differential Input Signals

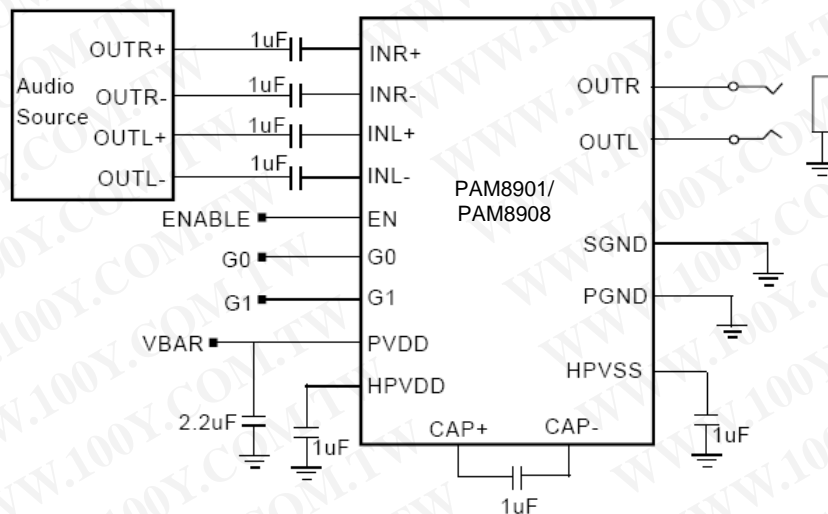

Typical Applications Circuit (cont.)

Typical Application Configuration with Single-Ended Input Signal

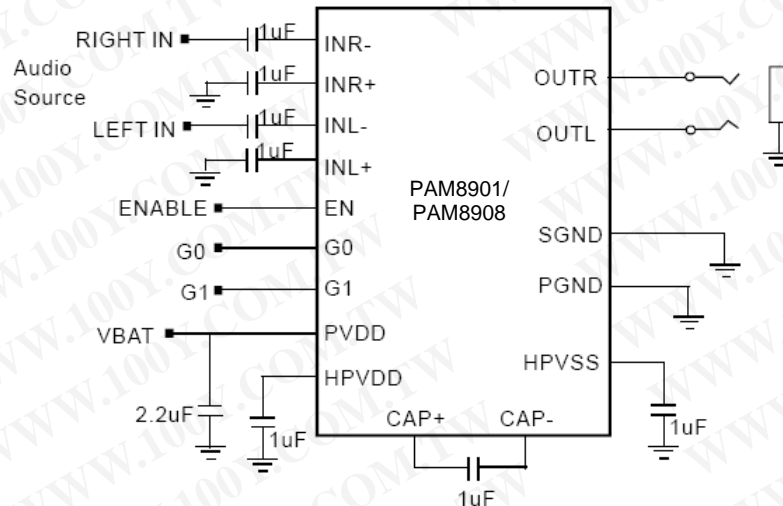

Pin Descriptions

Pin Number		T-QFN3x3-16L Pin Name	I/O/P	Function
PAM8901	PAM8908			
1	1	INL-	I	Inverting left input for differential signals.
2	2	INL+	I	Non-inverting left input for differential signals.
3	3	INR+	I	Inverting right input for differential signals.
4	4	INR-	I	Non-inverting right input for differential signals.
5	6	G0	I	Gain select bit 0
6	7	G1	I	Gain select bit 1
7	5	OUTR	O	Right headphone amplifier output. Connect to right terminal of headphone jack.
8	8	HPVSS	P	Charge pump output and negative power supply for output amplifiers; connect 1µF capacitor to GND
9	10	PGND	P	Power Ground
10	9	CAP-	O	Charge pump negative flying cap.
11	11	CAP+	O	Charge pump positive flying cap.
12	14	PVDD	P	Power V _{DD} .
13	12	HPVDD	O	Positive power supply for headphone amplifiers. Charge pump positive half V _{DD} output.
14	16	OUTL	O	Left headphone amplifier output. Connect to left terminal of headphone jack.
15	15	SGND	I	Amplifier reference voltage.
16	13	EN	I	Amplifier enabled. Connect to logic low to shutdown; connect to logic high to activate

Functional Block Diagram

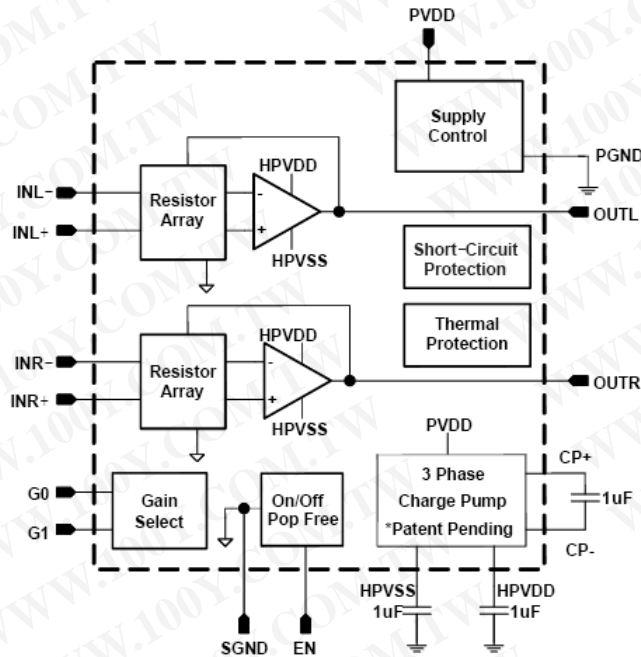

Absolute Maximum Ratings (@T_A = +25°C, unless otherwise specified.)

These are stress ratings only and functional operation is not implied. Exposure to absolute maximum ratings for prolonged time periods may affect device reliability. All voltages are with respect to ground.

Parameter	Rating	Unit
Supply Voltage (PV _{DD})	6.0	V
Input Voltage (INR+, INR-, INL+, INL-)	HPV _{SS} -0.3 to HPV _{DD} +0.3	V
Control Interface Voltage (G0, G1, EN)	-0.3 to PV _{DD} +0.3	V
Storage Temperature	-65 to +150	°C
Maximum Junction Temperature	150	
Soldering Temperature	250, 10sec	

Recommended Operating Conditions (@T_A = +25°C, unless otherwise specified.)

Parameter	Rating	Unit
Supply Voltage Range	2.5 to 5.5	V
Ambient Temperature Range	-40 to +85	°C
Junction Temperature Range	-40 to +125	

Thermal Information

Parameter	Symbol	Package	Max	Unit
Thermal Resistance (Junction to Ambient)	θ _{JA}	TQFN3x3-16	35	°C/W
Thermal Resistance (Junction to Case)	θ _{JC}	TQFN3x3-16	14	°C/W

Electrical Characteristics (@ $T_A = +25^\circ\text{C}$, $PVDD = 3.6\text{V}$, $R_L = 16\Omega$ unless otherwise specified.)

Parameter	Symbol	Test Conditions	Min	Typ	Max	Units
Supply Voltage	PV_{DD}		2.5		5.5	V
Quiescent Current	I_Q	EN = PVDD, No Load		4		mA
Output Power per Channel	P_O	THD = 1%, f = 1kHz, $R_L = 16\Omega$		35		
		THD = 1%, f = 1kHz, $R_L = 32\Omega$		25		mW
Shutdown Current	I_{SD}	EN = 0V, $PVDD = 2.5\text{V}$ to 5.5V		0.1	1	μA
EN High Level Input Voltage	V_{IH}		1.4			V
EN Low Level Voltage	V_{IL}				0.6	V
G0, G1 High Level Input Voltage	V_{GH}		1.4			V
G0, G1 Low Level Voltage	V_{GL}				0.6	V
Output Offset Voltage	V_{OS}			1	5	mV
Closed-Loop Voltage Gain	AV	G0 = 0V, G1 = 0V		-6		dB
		G0 = PVDD, G1 = 0V		0		dB
		G0 = 0V, G1 = PVDD		3		dB
		G0 = PVDD, G1 = PVDD		6		dB
Power Supply Rejection Ratio	PSRR	Input A C-GND, f = 1kHz, $V_{PP} = 200\text{mV}$		75		dB
Total Harmonic Distortion Plus Noise	THD+N	$P_O = 20\text{mW}$, f = 1kHz		0.03		%
Signal to Noise Ratio	SNR	$P_O = 20\text{mW}$, into 16Ω		100		dB
Noise Output Voltage	EN	A-Weighted		10		μV_{RMS}
Crosstalk	CS	$P_O = 15\text{mW}$, f = 1kHz		80		dB
Chargepump Switching Frequency	f_{osc}		1.2	1.5	1.8	MHz
Start-Up Time	t_{ON}	EN from low to high		0.4		Ms
Thermal Shutdown	OTP	Threshold		150		$^\circ\text{C}$
Thermal Shutdown Hysteresis	OTPH	Hysteresis		20		$^\circ\text{C}$

Typical Performance Characteristics (@ $T_A = +25^\circ\text{C}$, PVDD=3.6V, $f = 1\text{kHz}$, Gain = 6dB, unless otherwise specified.)

1. THD+N vs Output Power

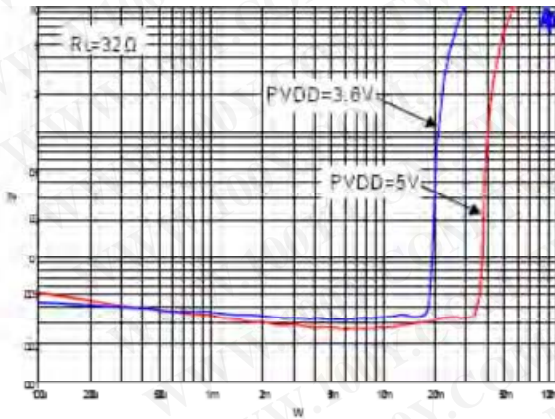

2. THD+N vs Output Power

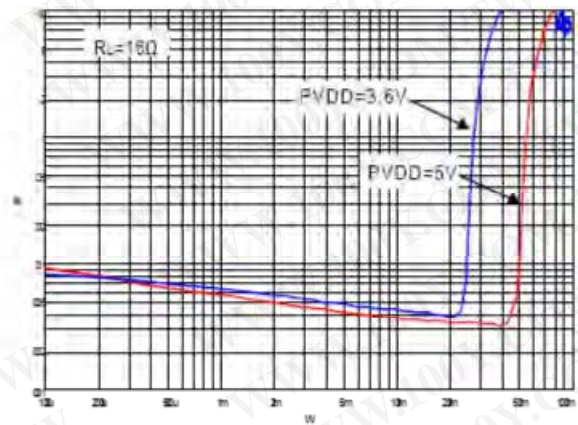

3. THD+N vs Frequency

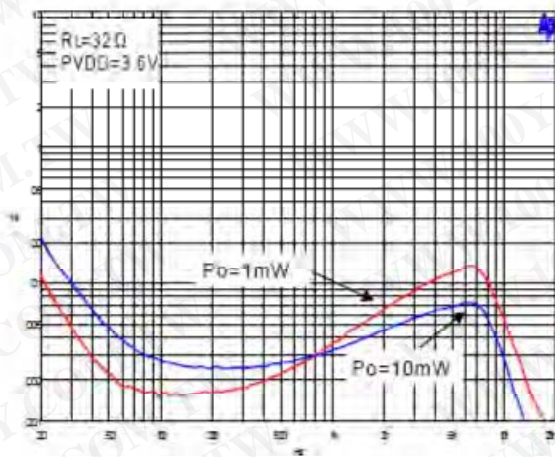

4. THD+N vs Frequency

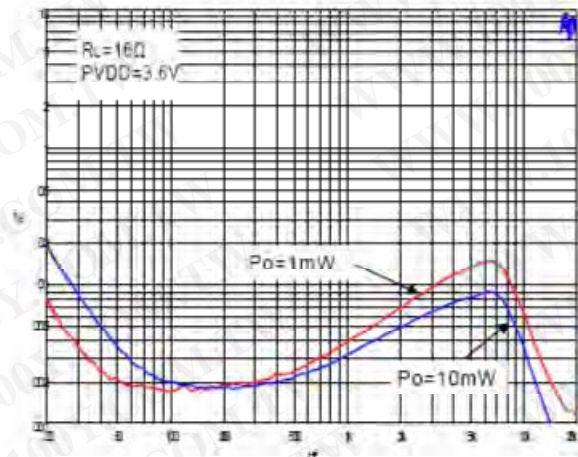

5. Frequency Response

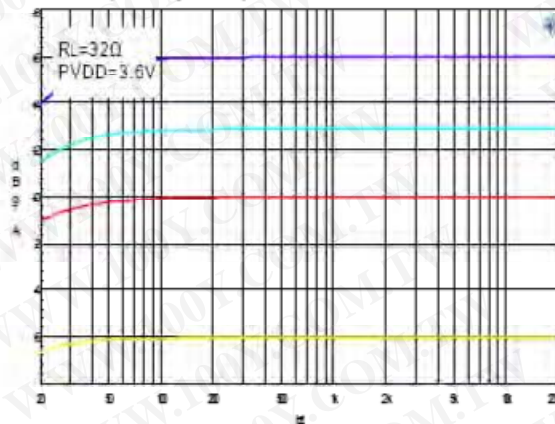

6. Frequency Response

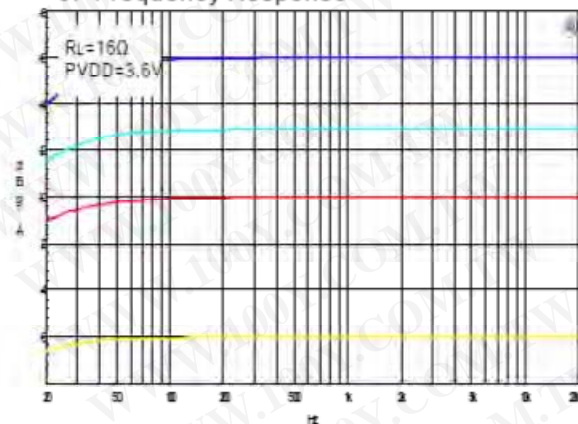

Typical Performance Characteristics (cont.) (@ $T_A=+25^{\circ}\text{C}$, $\text{PVDD}=3.6\text{V}$, $f=1\text{kHz}$, $\text{Gain}=6\text{dB}$, unless otherwise specified.)

7. Crosstalk

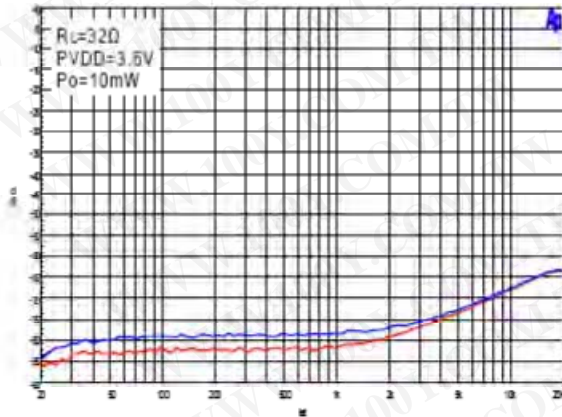

8. Crosstalk

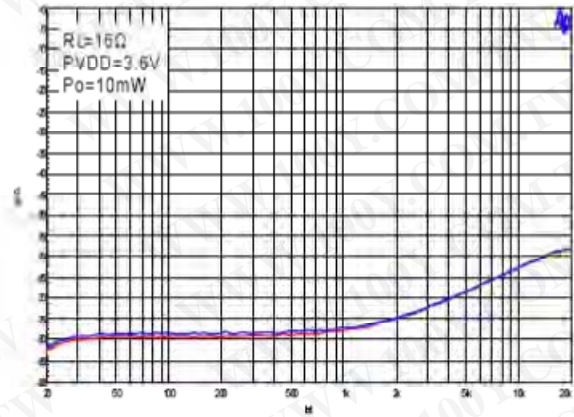

9. PSRR

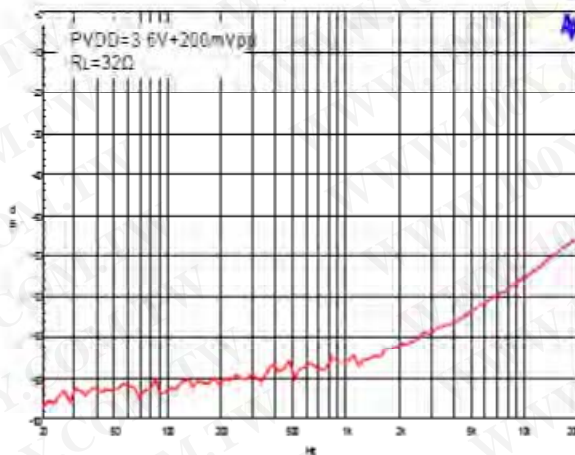

10. PSRR

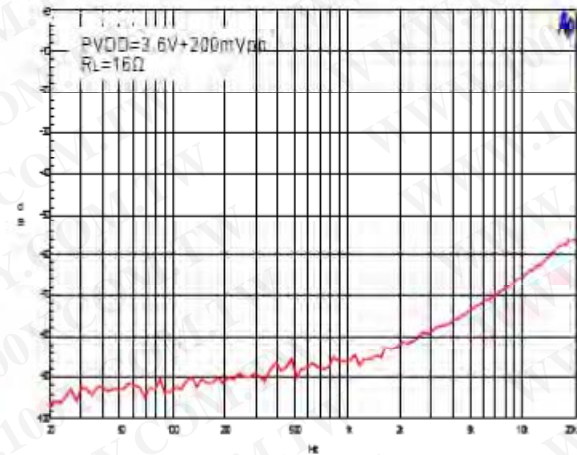

11. FFT Noise

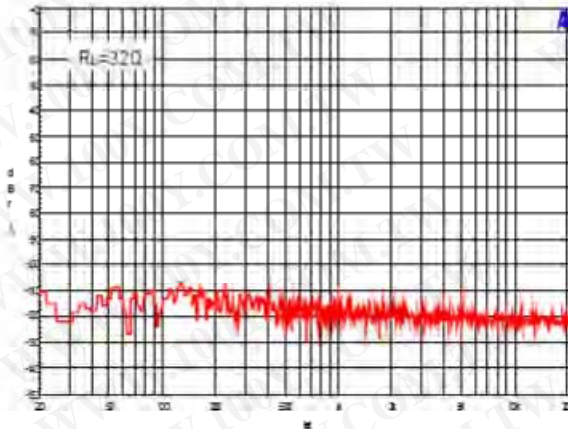

12. FFT Noise

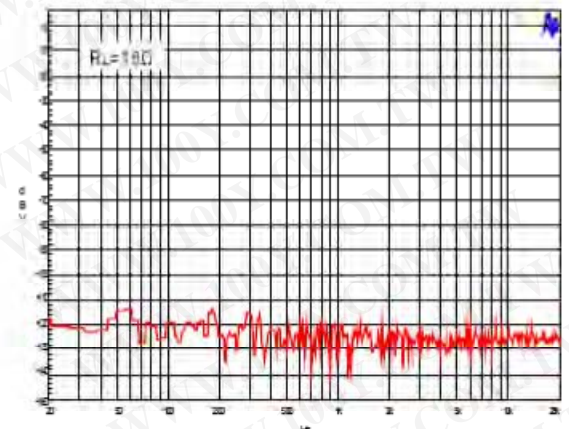

Typical Performance Characteristics (cont.) (@ $T_A = +25^\circ\text{C}$, $C_{IN}=10\mu\text{F}$, $C_O=10\mu\text{F}$, $L=4.7\mu\text{H}$, unless otherwise specified.)

13. Start up with signal



14. Shutdown with signal



15. Start up without signal

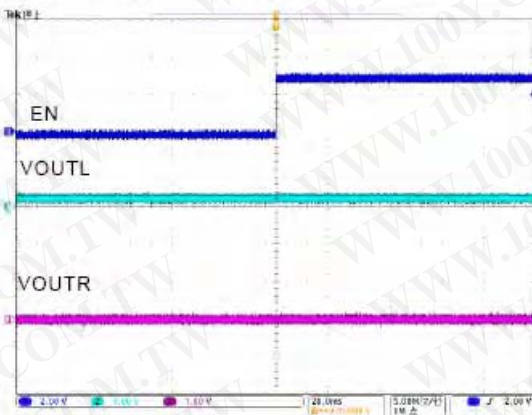

16. Shutdown without signal

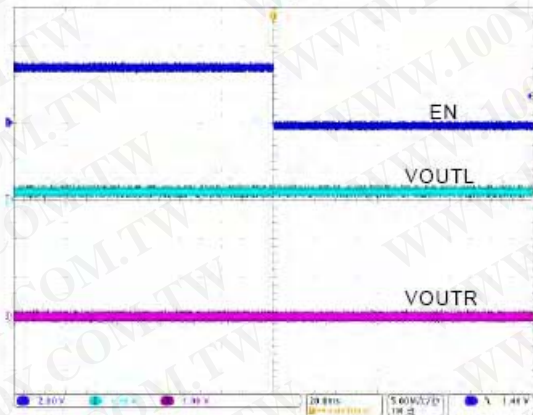

17. Output Voltage vs Supply Voltage

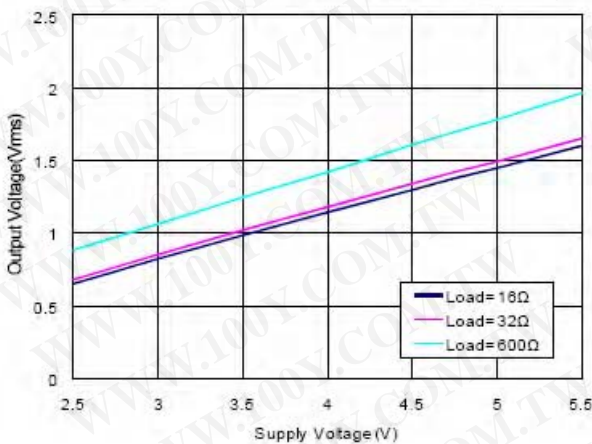

Application Information

The basic PAM8901 / PAM8908 application circuit is shown in page 1 and page 2.

Gain Control

The PAM8901 / PAM8908 has four gain settings which are controlled with pins G0 and G1. The following table gives an overview of the gain function.

G0 Voltage	G1 Voltage	Amplifier Gain
≤0.6V	≤0.6V	-6dB
≥1.4V	≤0.6V	0dB
≤0.6V	≥1.4V	3dB
≥1.4V	≥1.4V	6dB

Input Coupling Capacitors

Input coupling capacitors block any DC bias from the audio source and ensure maximum dynamic range. Input coupling capacitors also minimize PAM8901 / PAM8908 turn-on pop to an inaudible level. The input capacitors are in series with PAM8901 / PAM8908 internal input resistors, creating a high-pass filter. The following Equation calculates the highpass filter corner frequency.

$$f_c = \frac{1}{2\pi R_{IN} C_{IN}}$$

The input impedance, R_{IN}, is dependent on device gain. Larger input capacitors decrease the corner frequency. See the following table for input impedance values.

G0 Voltage	G1 Voltage	R _{IN}
≤0.6V	≤0.6V	26.4kΩ
≥1.4V	≤0.6V	19.8kΩ
≤0.6V	≥1.4V	16.5kΩ
≥1.4V	≥1.4V	13.2kΩ

For a given high-pass cutoff frequency, the minimum input coupling capacitor is found as:

$$C_{IN} = \frac{1}{2\pi f_c R_{IN}}$$

Example: Design for a 20Hz corner frequency with a PAM8901 / PAM8908 gain of +6dB. The input impedance table gives R_{IN} as 13.2kΩ. The C_{IN} Equation shows the input coupling capacitors must be at least 0.6μF to achieve a 20Hz highpass corner frequency. Choose a 0.68μF standard value capacitor for each PAM8901 / PAM8908 input (X5R material or better is required for best performance).

Charge Pump Flying Capacitor, HPVDD Capacitor and HPVSS Capacitor

The PAM8901 / PAM8908 uses a built-in charge pump to generate a positive and negative voltage supply for the headphone amplifiers. The charge pump flying capacitor connects between CAP+ and CAP-. It transfers charge to generate the positive and negative supply voltage. The HPVDD capacitor or HPVSS capacitor must be at least equal in or larger than value to the flying capacitor to allow maximum charge transfer. Use low equivalent-series-resistance (ESR) ceramic capacitors (X5R material or better is required for best performance) to maximize charge pump efficiency. Typical values are 1μF for the HPVDD, HPVSS and flying capacitors.

Power Supply Decoupling Capacitors

The PAM8901 / PAM8908 TrueCapFree headphone amplifier requires adequate power supply decoupling to ensure that output noise and total harmonic distortion (THD) remain low. Use good low equivalent-series-resistance (ESR) ceramic capacitors (X5R material or better is required for best performance). Place a 2.2μF capacitor within 5mm of the PVDD pin. Reducing the distance between the decoupling capacitor and PVDD minimizes parasitic inductance and resistance, improving PAM8901 / PAM8908 supply rejection performance. Use 0402 or smaller size capacitors if possible.

Power Supply Sequencing

Use input coupling capacitors to ensure inaudible turn-on pop. Activate the PAM8901 / PAM8908 after all audio sources have been activated and their output voltages have settled. On power down, deactivate the PAM8901 / PAM8908 before deactivating the audio input source. The EN pin controls device shutdown: Set to 0.6V or lower to deactivate the PAM8901 / PAM8908; set to 1.4V or higher to activate.

Application Information (cont.)

TrueCapFree Headphone Amplifiers

The TrueCapFree amplifier architecture operates from a single supply voltage and uses two internal charge pumps to generate a positive supply and a rail for the headphone amplifier. The output voltages are centered around 0V and are capable of positive and negative voltage swings as shown in the following drawing.

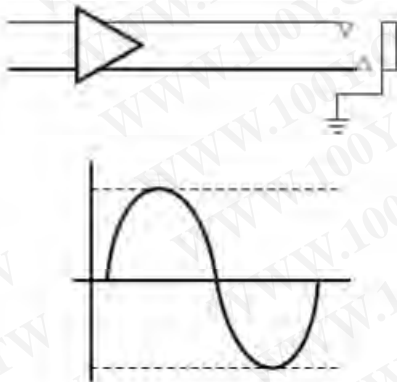

TrueCapFree amplifiers require no output DC-blocking capacitors. The headphone connector shield pin connects to ground and will interface with headphones and non-headphone accessories. The PAM8901 / PAM8908 is a TrueCapFree amplifier.

LAYOUT RECOMMENDATIONS

Exposed Pad on PAM8901 / PAM8908

Solder the exposed metal pad on the PAM8901 / PAM8908 TQFN package to the landing pad on the PCB. Connect the landing pad to ground or leave it electrically unconnected (floating). Do not connect the landing pad to PVDD or to any other power supply voltage. If the pad is grounded, it must be connected to the same ground as the PGND. Soldering the thermal pad is required for mechanical reliability and enhances thermal conductivity of the package.

GND Connections

The SGND pin is an input reference and must be connected to the headphone ground connector pin. This ensures no turn-on pop and minimizes output offset voltage. Do not connect more than $\pm 0.3V$ to SGND.

PGND is a power ground. Connect supply decoupling capacitors for PVDD, HPVDD, and HPVSS to PGND.

Power Supply Connections

Connect the supply voltage to the PVDD pin and decouple it with an X5R or better capacitor. Place both PVDD capacitor within 5mm of PVDD pin on the PAM8901 / PAM8908. Ensure that the ground connection of PVDD capacitor has a minimum length return path to the device. Failure to properly decouple the PAM8901 / PAM8908 may degrade audio or EMC performance.

Ordering Information

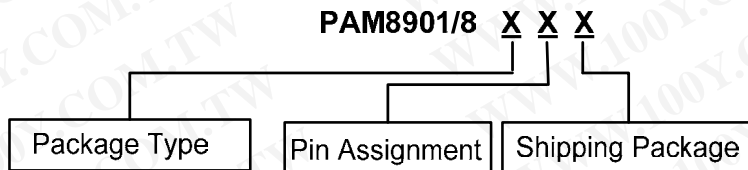

Part Number	Package Type	Standard Package
PAM8901JER	TQFN3x3-16L	3000 Units/ Tape & Reel
PAM8908JER	TQFN3x3-16L	3000 Units/ Tape & Reel

Marking Information

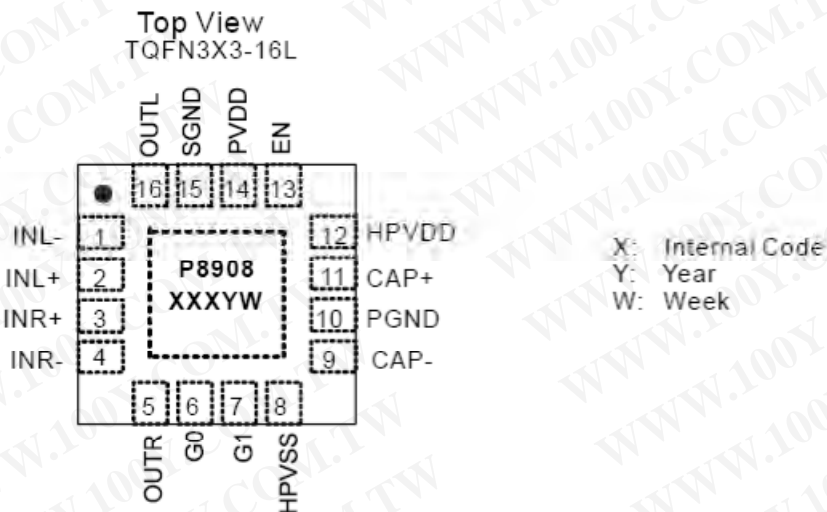
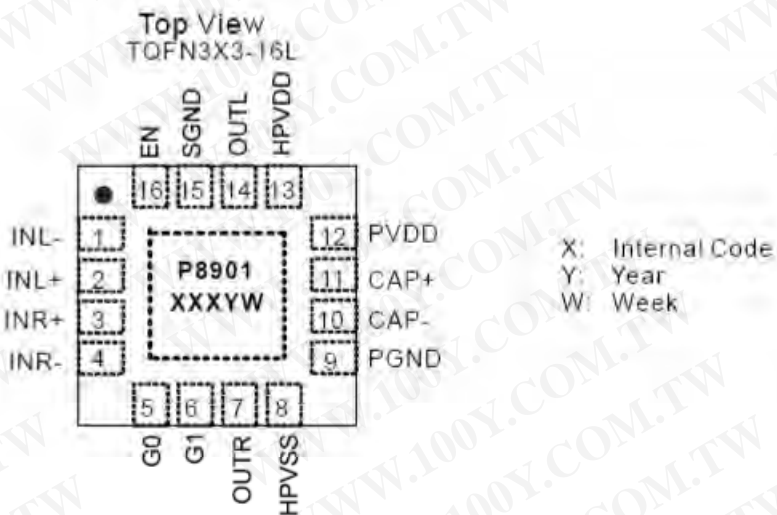

Package Outline Dimensions (All dimensions in mm.)

TQFN3x3mm-16

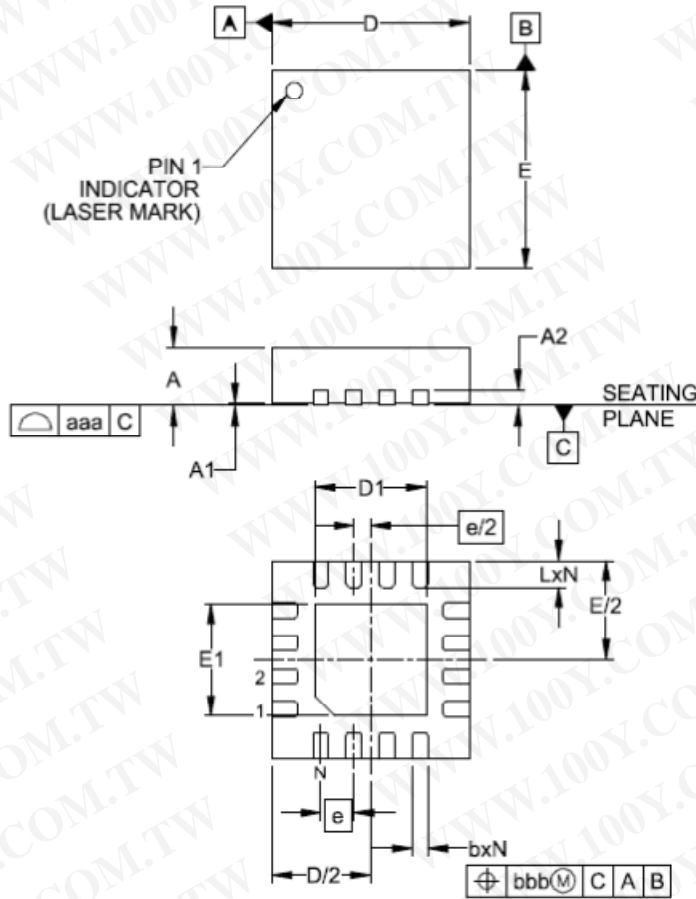

DIMENSIONS (Millimeters)			
	MIN	TYP	MAX
A	0.40	0.50	0.60
A1	0.00	0.02	0.05
A2	0.20		
b	0.18	0.25	0.30
D	2.90	3.00	3.10
D1	1.55	1.70	1.80
E	2.90	3.00	3.10
E1	1.55	1.70	1.80
e	0.50BSC		
L	0.30	0.40	0.50
N	16		
aaa	0.08		
bbb	0.10		

- Notes:
1. Controlling dimensions are in millimeters (angles in degrees).
 2. Coplanarity applies to the exposed pad as well as the terminals.
 3. DAP is 1.90 x 1.90mm.

IMPORTANT NOTICE

DIODES INCORPORATED MAKES NO WARRANTY OF ANY KIND, EXPRESS OR IMPLIED, WITH REGARDS TO THIS DOCUMENT, INCLUDING, BUT NOT LIMITED TO, THE IMPLIED WARRANTIES OF MERCHANTABILITY AND FITNESS FOR A PARTICULAR PURPOSE (AND THEIR EQUIVALENTS UNDER THE LAWS OF ANY JURISDICTION).

Diodes Incorporated and its subsidiaries reserve the right to make modifications, enhancements, improvements, corrections or other changes without further notice to this document and any product described herein. Diodes Incorporated does not assume any liability arising out of the application or use of this document or any product described herein; neither does Diodes Incorporated convey any license under its patent or trademark rights, nor the rights of others. Any Customer or user of this document or products described herein in such applications shall assume all risks of such use and will agree to hold Diodes Incorporated and all the companies whose products are represented on Diodes Incorporated website, harmless against all damages.

Diodes Incorporated does not warrant or accept any liability whatsoever in respect of any products purchased through unauthorized sales channel. Should Customers purchase or use Diodes Incorporated products for any unintended or unauthorized application, Customers shall indemnify and hold Diodes Incorporated and its representatives harmless against all claims, damages, expenses, and attorney fees arising out of, directly or indirectly, any claim of personal injury or death associated with such unintended or unauthorized application.

Products described herein may be covered by one or more United States, international or foreign patents pending. Product names and markings noted herein may also be covered by one or more United States, international or foreign trademarks.

LIFE SUPPORT

Diodes Incorporated products are specifically not authorized for use as critical components in life support devices or systems without the express written approval of the Chief Executive Officer of Diodes Incorporated. As used herein:

A. Life support devices or systems are devices or systems which:

1. are intended to implant into the body, or
2. support or sustain life and whose failure to perform when properly used in accordance with instructions for use provided in the labeling can be reasonably expected to result in significant injury to the user.

B. A critical component is any component in a life support device or system whose failure to perform can be reasonably expected to cause the failure of the life support device or to affect its safety or effectiveness.

Customers represent that they have all necessary expertise in the safety and regulatory ramifications of their life support devices or systems, and acknowledge and agree that they are solely responsible for all legal, regulatory and safety-related requirements concerning their products and any use of Diodes Incorporated products in such safety-critical, life support devices or systems, notwithstanding any devices- or systems-related information or support that may be provided by Diodes Incorporated. Further, Customers must fully indemnify Diodes Incorporated and its representatives against any damages arising out of the use of Diodes Incorporated products in such safety-critical, life support devices or systems.

Copyright © 2012, Diodes Incorporated

www.diodes.com