

# LM2903/LM2903I, LM393/LM393A, LM293/LM293A

## Dual Differential Comparator

### Features

- Single Supply Operation: 2V to 36V
- Dual Supply Operation:  $\pm 1V$  to  $\pm 18V$
- Allow Comparison of Voltages Near Ground Potential
- Low Current Drain 800 $\mu A$  Typ.
- Compatible with all Forms of Logic
- Low Input Bias Current 25nA Typ.
- Low Input Offset Current  $\pm 5nA$  Typ.
- Low Offset Voltage  $\pm 1mV$  Typ.

### Description

The LM2903/LM2903I, LM393/LM393A, LM293/LM293A consist of two independent voltage comparators designed to operate from a single power supply over a wide voltage range.

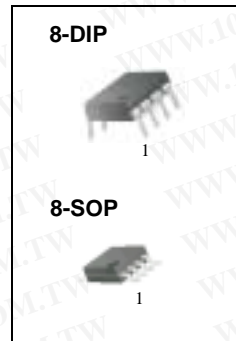

### Internal Block Diagram

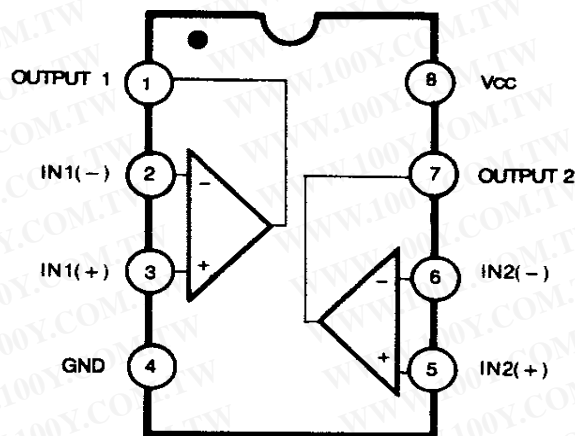

勝特力材料 886-3-5753170  
 勝特力电子(上海) 86-21-34970699  
 勝特力电子(深圳) 86-755-83298787  
[Http://www.100y.com.tw](http://www.100y.com.tw)

## Schematic Diagram

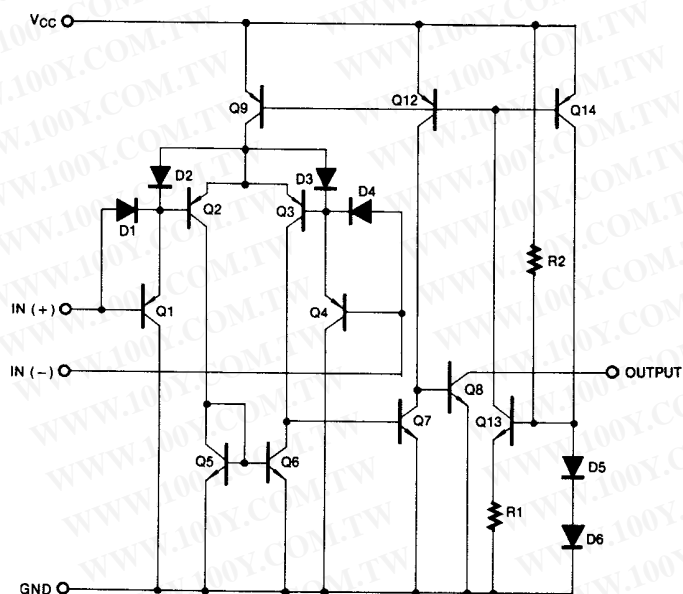

## Absolute Maximum Ratings

Parameter	Symbol	Value	Unit
Power Supply Voltage	VCC	±18 or 36	V
Differential Input Voltage	V <sub>I(DIFF)</sub>	36	V
Input Voltage	V <sub>I</sub>	- 0.3 to +36	V
Output Short Circuit to GND	-	Continuous	-
Power Dissipation, T <sub>a</sub> = 25°C	P <sub>D</sub>	1040	mW
8-DIP 8-SOP		480	
Operating Temperature	TOPR	0 ~ +70	°C
LM393/LM393A		- 40 ~ +85	
LM2903		-40 ~ +105	
LM2903I LM293/LM293A		-25 ~ +85	
Storage Temperature	TSTG	- 65 ~ +150	°C

## Thermal Data

Parameter	Symbol	Value	Unit
Thermal Resistance Junction-Ambient Max.	R <sub>θja</sub>	120	°C/W
8-DIP 8-SOP		260	

勝特力材料 886-3-5753170  
 勝特力电子(上海) 86-21-34970699  
 勝特力电子(深圳) 86-755-83298787  
[Http://www.100y.com.tw](http://www.100y.com.tw)

## Electrical Characteristics

( $V_{CC} = 5V$ ,  $T_A = 25^\circ C$ , unless otherwise specified)

Parameter	Symbol	Conditions	LM293A/LM393A			LM293/LM393			Unit
			Min.	Typ.	Max.	Min.	Typ.	Max.	
Input Offset Voltage	$V_{IO}$	$V_{O(P)} = 1.4V$ , $R_S = 0\Omega$	-	$\pm 1$	$\pm 2$	-	$\pm 1$	$\pm 5$	mV
		$V_{CM} = 0$ to $1.5V$   Note 1	-	-	$\pm 4.0$	-	-	$\pm 9.0$	
Input Offset Current	$I_{IO}$		-	$\pm 5$	$\pm 50$	-	$\pm 5$	$\pm 50$	nA
		Note 1	-	-	$\pm 150$	-	-	$\pm 150$	
Input Bias Current	$I_{BIAS}$		-	65	250	-	65	250	nA
		Note 1	-	-	400	-	-	400	
Input Common Mode Voltage Range	$V_{I(R)}$		0	-	$V_{CC} - 1.5$	0	-	$V_{CC} - 1.5$	V
		Note 1	0	-	$V_{CC} - 2$	0	-	$V_{CC} - 2$	
Supply Current	$I_{CC}$	$R_L = \infty$ , $V_{CC} = 5V$	-	0.6	1	-	0.6	1	mA
		$R_L = \infty$ , $V_{CC} = 30V$	-	0.8	2.5	-	0.8	2.5	
Voltage Gain	$G_V$	$V_{CC} = 15V$ , $R_L \geq 15K\Omega$ (for large $V_{O(P-P)}$ swing)	50	200	-	50	200	-	V/mV
Large Signal Response Time	$T_{LRES}$	$V_I = \text{TTL Logic Swing}$ $V_{REF} = 1.4V$ , $V_{RL} = 5V$ , $R_L = 5.1K\Omega$	-	350	-	-	350	-	nS
Response Time	$T_{RES}$	$V_{RL} = 5V$ , $R_L = 5.1K\Omega$	-	1.4	-	-	1.4	-	$\mu S$
Output Sink Current	$I_{SINK}$	$V_{I(-)} \geq 1V$ , $V_{I(+)} = 0V$ , $V_{O(P)} \leq 1.5V$	6	18	-	6	18	-	mA
Output Saturation Voltage	$V_{SAT}$	$V_{I(-)} \geq 1V$ , $V_{I(+)} = 0V$	-	160	400	-	160	400	mV
		$I_{SINK} = 4mA$   Note 1	-	-	700	-	-	700	
Output Leakage Current	$I_{O(LKG)}$	$V_{I(-)} = 0V$ , $V_{I(+)} = 1V$	-	0.1	-	-	0.1	-	nA
		$V_{O(P)} = 30V$	-	-	1.0	-	-	1.0	$\mu A$

### NOTE 1

LM393/LM393A:  $0 \leq T_A \leq +70^\circ C$

LM2903:  $-40 \leq T_A \leq +85^\circ C$

LM2903I:  $-40 \leq T_A \leq +105^\circ C$

LM293/LM293A:  $-25 \leq T_A \leq +85^\circ C$

勝特力材料 886-3-5753170  
 勝特力电子(上海) 86-21-34970699  
 勝特力电子(深圳) 86-755-83298787  
[Http://www.100y.com.tw](http://www.100y.com.tw)

**Electrical Characteristics** (Continued)

(VCC = 5V, TA = 25°C, unless otherwise specified)

Parameter	Symbol	Conditions	LM2903/LM2903I			Unit
			Min.	Typ.	Max.	
Input Offset Voltage	V <sub>IO</sub>	V <sub>O(P)</sub> = 1.4V, R <sub>S</sub> = 0Ω	-	±1	±7	mV
		V <sub>CM</sub> = 0 to 1.5V   Note 1	-	±9	±15	
Input Offset Current	I <sub>IO</sub>		-	±5	±50	nA
		Note 1	-	±50	±200	
Input Bias Current	I <sub>BIAS</sub>		-	65	250	nA
		Note 1	-	-	500	
Input Common Mode Voltage Range	V <sub>I(R)</sub>		0	-	V <sub>CC</sub> -1.5	V
		Note 1	0	-	V <sub>CC</sub> -2	
Supply Current	I <sub>CC</sub>	R <sub>L</sub> = ∞, V <sub>CC</sub> = 5V	-	0.6	1	mA
		R <sub>L</sub> = ∞, V <sub>CC</sub> = 30V	-	1	2.5	
Voltage Gain	G <sub>V</sub>	V <sub>CC</sub> = 15V, R <sub>L</sub> ≥ 15KΩ (for large V <sub>O(P-P)</sub> swing)	25	100	-	V/mV
Large Signal Response Time	T <sub>LRES</sub>	V <sub>I</sub> = TTL Logic Swing V <sub>REF</sub> = 1.4V, V <sub>R</sub> L = 5V, R <sub>L</sub> = 5.1KΩ	-	350	-	nS
Response Time	T <sub>RES</sub>	V <sub>R</sub> L = 5V, R <sub>L</sub> = 5.1KΩ	-	1.5	-	μS
Output Sink Current	I <sub>SINK</sub>	V <sub>I(-)</sub> ≥ 1V, V <sub>I(+)</sub> = 0V, V <sub>O(P)</sub> ≤ 1.5V	6	16	-	mA
Output Saturation Voltage	V <sub>SAT</sub>	V <sub>I(-)</sub> ≥ 1V, V <sub>I(+)</sub> = 0V	-	160	400	mV
		I <sub>SINK</sub> = 4mA   Note 1	-	-	700	
Output Leakage Current	I <sub>O(LKG)</sub>	V <sub>I(-)</sub> = 0V, V <sub>O(P)</sub> = 5V	-	0.1	-	nA
		V <sub>I(+)</sub> = 1V, V <sub>O(P)</sub> = 30V	-	-	1.0	μA

**Note 1**

LM393/LM393A: 0 ≤ TA ≤ +70°C

LM2903: -40 ≤ TA ≤ +85°C

LM2903I: -40 ≤ TA ≤ +105°C

LM293/LM293A: -25 ≤ TA ≤ +85°C

勝特力材料 886-3-5753170  
 勝特力电子(上海) 86-21-34970699  
 勝特力电子(深圳) 86-755-83298787  
[Http://www.100y.com.tw](http://www.100y.com.tw)

## Typical Performance Characteristics

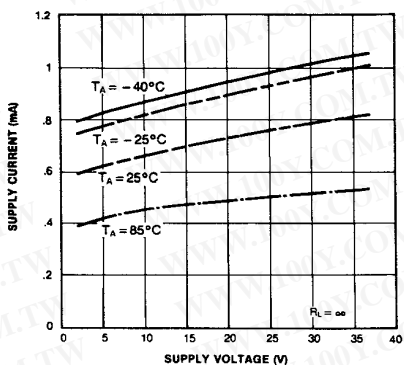

Figure 1. Supply Current vs Supply Voltage

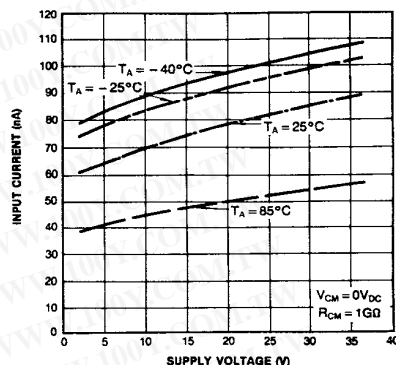

Figure 2. Input Current vs Supply Voltage

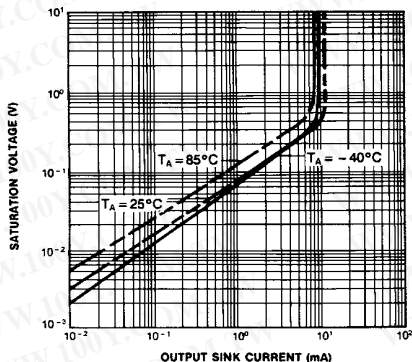

Figure 3. Output Saturation Voltage vs Sink Current

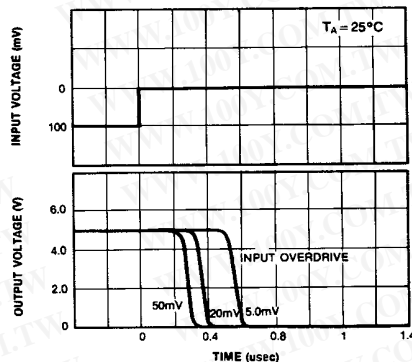

Figure 4. Response Time for Various Input Overdrive-Negative Transition

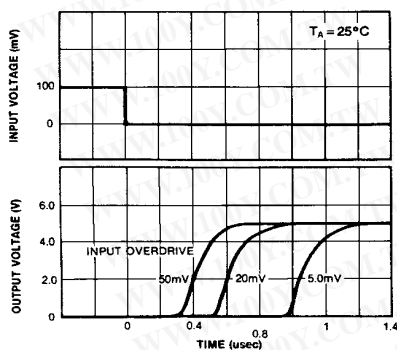

Figure 5. Response Time for Various Input Overdrive-Positive Transition

勝特力材料 886-3-5753170  
 勝特力电子(上海) 86-21-34970699  
 勝特力电子(深圳) 86-755-83298787  
[Http://www.100y.com.tw](http://www.100y.com.tw)

# Mechanical Dimensions

Package

Dimensions in millimeters

## 8-DIP

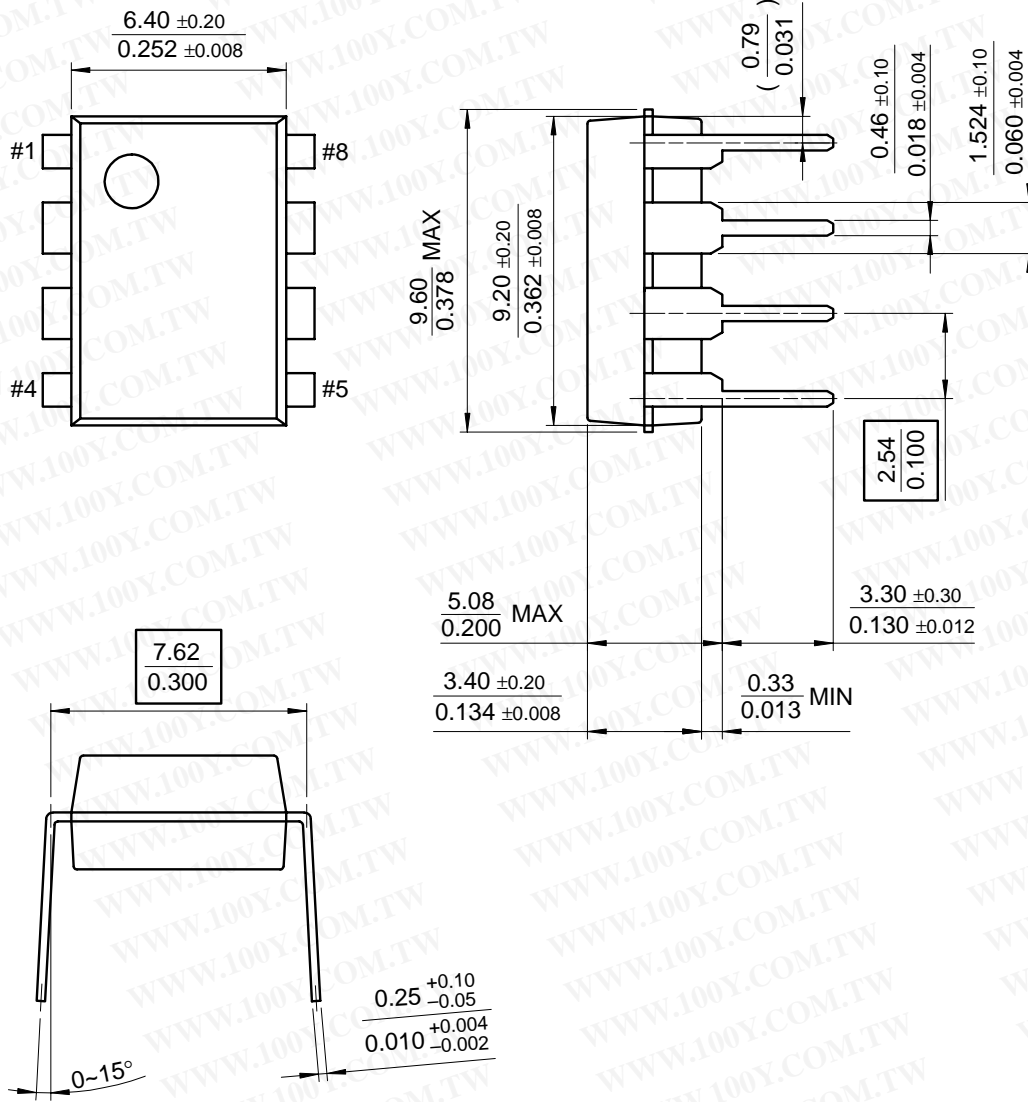

勝特力材料 886-3-5753170  
 勝特力电子(上海) 86-21-34970699  
 勝特力电子(深圳) 86-755-83298787  
[Http://www.100y.com.tw](http://www.100y.com.tw)



## Ordering Information

Product Number	Package	Operating Temperature
LM393N	8-DIP	0 ~ + 70°C
LM393AN		
LM393M	8-SOP	
LM393AM		
LM2903N	8-DIP	-40 ~ + 85°C
LM2903M	8-SOP	
LM2903IN	8-DIP	-40 ~ + 105°C
LM2903IM	8-SOP	
LM293N	8-DIP	-25 ~ + 85°C
LM293AN		
LM293M	8-SOP	
LM293AM		

勝特力材料 886-3-5753170  
 勝特力电子(上海) 86-21-34970699  
 勝特力电子(深圳) 86-755-83298787  
[Http://www.100y.com.tw](http://www.100y.com.tw)

### DISCLAIMER

FAIRCHILD SEMICONDUCTOR RESERVES THE RIGHT TO MAKE CHANGES WITHOUT FURTHER NOTICE TO ANY PRODUCTS HEREIN TO IMPROVE RELIABILITY, FUNCTION OR DESIGN. FAIRCHILD DOES NOT ASSUME ANY LIABILITY ARISING OUT OF THE APPLICATION OR USE OF ANY PRODUCT OR CIRCUIT DESCRIBED HEREIN; NEITHER DOES IT CONVEY ANY LICENSE UNDER ITS PATENT RIGHTS, NOR THE RIGHTS OF OTHERS.