

High Voltage Power Operational Amplifiers

FEATURES

- RoHS COMPLIANT
- LOW COST
- WIDE BANDWIDTH - 1.1 Mhz
- HIGH OUTPUT CURRENT - 1A per amplifier
- WIDE COMMON MODE RANGE Includes negative supply
- WIDE SUPPLY VOLTAGE RANGE Single supply: 5V to 40V Split supplies: $\pm 2.5V$ to $\pm 20V$
- LOW QUIESCIENT CURRENT
- VERY LOW DISTORTION

APPLICATIONS

- HALF AND FULL BRIDGE MOTOR DRIVERS
- AUDIO POWER AMPLIFIER
 - Stereo - 15.91W RMS per channel
 - Bridge - 31.82W RMS per 2 channels
- IDEAL FOR SINGLE SUPPLY SYSTEMS
 - 5V - Peripherals
 - 12V - Automotive
 - 28V - Avionic

DESCRIPTION

The amplifier design is a dual power op amp on a single monolithic die. This approach provides a cost-effective solution to applications where multiple amplifiers are required or a bridge configuration is needed. Very low harmonic distortion of 0.02% THD and low I_Q makes the PA60 a good solution for low power audio applications such as laptops and computer speakers.

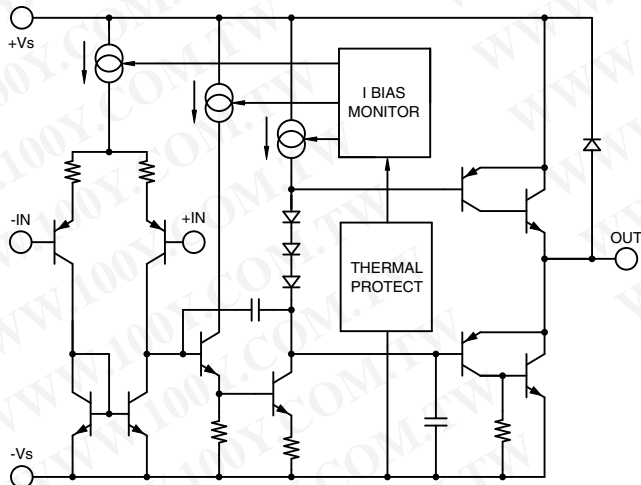

FIGURE 1. Equivalent schematic (one channel)

The dual output PA60EU, is available in a 12-Pin Molded Plastic SIP with standard 100 mil spacing. The heat tab of EU package is tied to -VS.



12-PIN SIP PACKAGE STYLE EU

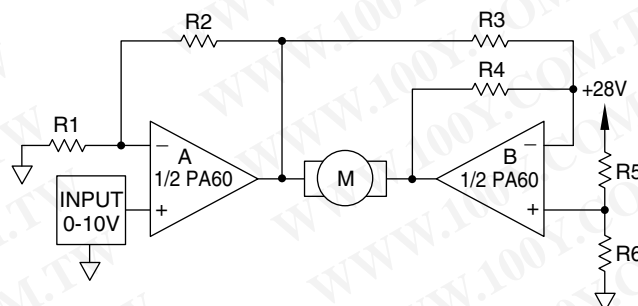

FIGURE 2. Bi-directional speed control from a single supply

TYPICAL APPLICATION

R1 and R2 set up Amplifier A as non-inverting. Amplifier B is set up as a unity gain inverter driven from the output of Amplifier A. Note that Amplifier B inverts the signals about the reference node, which is set at mid-supply by R5 and R6. When the command input is midrange, so is the output of Amplifier A. Since this is also equivalent to the reference node voltage, the output of Amplifier B is the same resulting in 0V across the motor. Inputs more positive than 5V result in motor current flow from left to right (see Figure 2). Inputs less than 5V drive the motor in the opposite direction.

The amplifiers are especially well-suited for applications such as this. The extended common mode range allows command inputs as low as 0V. The output swing lets it drive within 2V of the supply at an output of 1A. This means that a command input that ranges from 0 to 10V will drive a 24V motor from full scale CCW to full scale CW at $\pm 1A$.

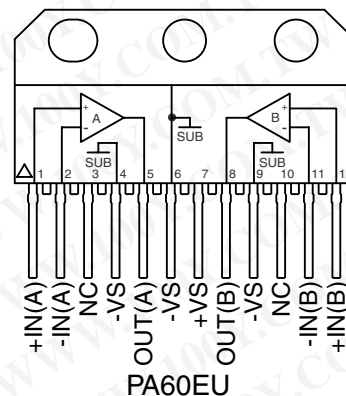

FIGURE 3. External connections



ABSOLUTE MAXIMUM RATINGS

SUPPLY VOLTAGE, total	5V to 40V
OUTPUT CURRENT	SOA
POWER DISSIPATION, internal (PA60EU, 1 amplifier)	19.89W
POWER DISSIPATION, internal (PA60EU, 2 amplifiers) ⁴	31.82W
INPUT VOLTAGE, differential	±Vs
INPUT VOLTAGE, common mode	+Vs, -Vs - 5V
JUNCTION TEMPERATURE, max. ¹	150°C
TEMPERATURE, pin solder - 10 secs max.	220°C
TEMP RANGE STORAGE	-55°C to 150°C
OPERATING TEMP RANGE, case ¹	-40°C to 125°C

SPECIFICATIONS (PER AMPLIFIER)

PARAMETER	TEST CONDITIONS ^{1,2}	MIN	TYP	MAX	UNTS
INPUT					
OFFSET VOLTAGE, initial			1	15	mV
OFFSET VOLTAGE, vs. temperature	Full temp range		20		μV/°C
BIAS CURRENT, initial			100	500	nA
COMMON MODE RANGE	Full temp range	-Vs		+Vs - 1.3	V
COMMON MODE REJECTION, DC		60	90		dB
POWER SUPPLY REJECTION	Full temp range	60	90		dB
CHANNEL SEPARATION	I _{OUT} = 500mA, f = 1kHz	50	68		dB
INPUT NOISE VOLTAGE	R _S = 100Ω, f = 1 to 100kHz		22		nV/√Hz
GAIN					
OPEN LOOP GAIN	V _O = ±10V, R _L = 2.0KΩ	89	100		dB
GAIN BANDWIDTH PRODUCT	f = 100kHz, C _L = 100pF, R _L = 2.0KΩ	0.9	1.4		MHz
PHASE MARGIN	Full temp range, C _L = 100pF, R _L = 2KΩ		65		°C
POWER BANDWIDTH	V _O (P-P) = 28V		13.6		kHz
OUTPUT					
CURRENT, peak				1.5	A
SLEW RATE		1.0	1.4		V/μS
VOLTAGE SWING	Full temp range, I _O = 100mA	V _S - 1.1	V _S - 0.8		V
VOLTAGE SWING	Full temp range, I _O = 1A	V _S - 1.8	V _S - 1.4		V
HARMONIC DISTORTION	A _V = 1, R _L = 50Ω, V _O = .5VRMS, f = 1kHz		.02		%
POWER SUPPLY					
VOLTAGE, V _{SS} ³		5	30	40	V
CURRENT, quiescent total			8	10	mA
THERMAL					
RESISTANCE, junction to case					
DC, 1 amplifier			5.71	6.29	°C/W
DC, 2 amplifiers ⁴			3.57	3.93	°C/W
AC, 1 amplifier			4.29	4.71	°C/W
AC, 2 amplifiers ⁴			2.68	2.95	°C/W
RESISTANCE, junction to air			30		°C/W

- Notes:
1. Long term operation at the maximum junction temperature will result in reduced product life. Derate internal power dissipation to achieve high MTTF.
 2. Unless otherwise noted, the following conditions apply: ±V_S = ±15V, T_C = 25°C.
 3. +V_S and -V_S denote the positive and negative rail respectively. V_{SS} denotes total rail-to-rail supply.
 4. Rating applies when power dissipation is equal in each of the amplifiers.
 5. If -V_S is disconnected before +V_S, a diode between -V_S and ground is recommended to avoid damage.

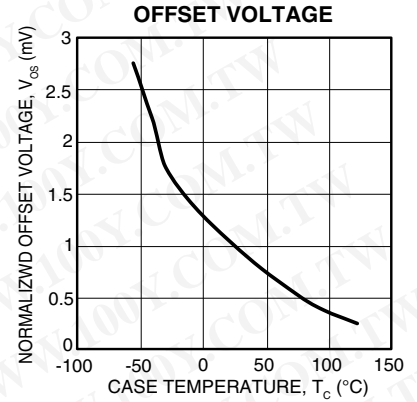
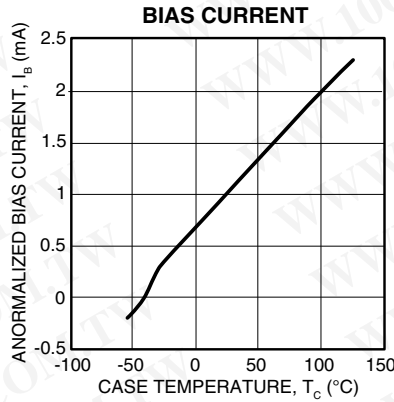
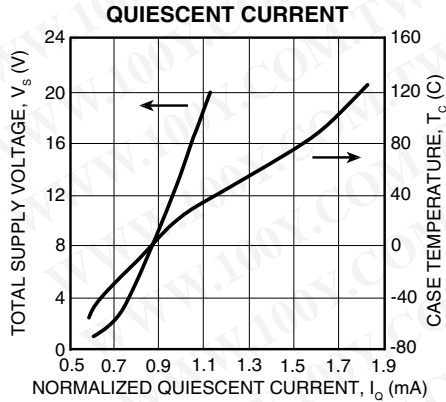

PHASE MARGIN vs. OUTPUT LOAD CAPACITANCE

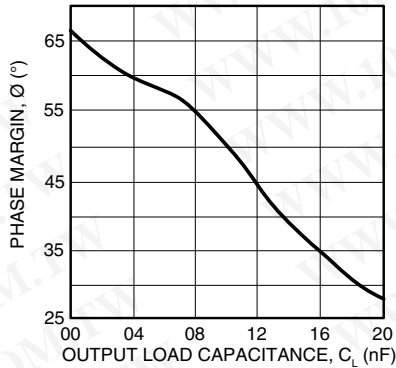

VOLTAGE GAIN & PHASE vs. FREQUENCY

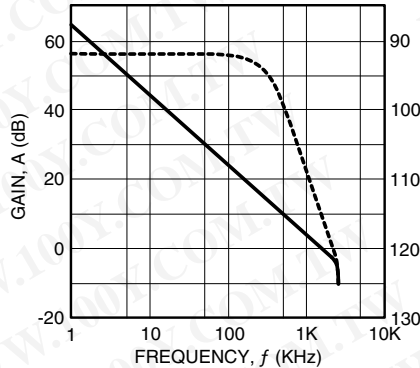

OUTPUT VOLTAGE SWING

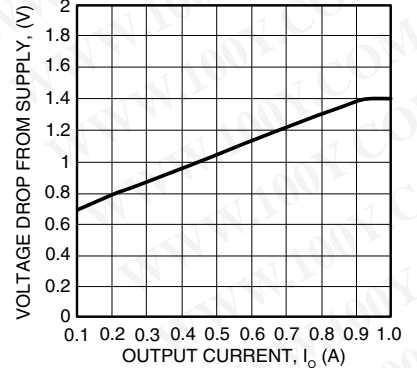

PULSE RESPONSE

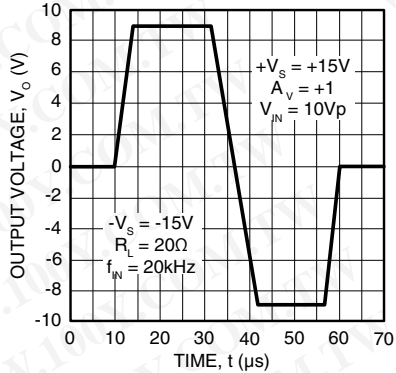

PULSE RESPONSE

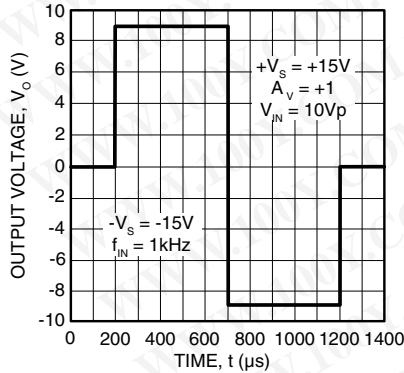

GENERAL

Please read Application Note 1 "General Operating Considerations" which covers stability, supplies, heatsinking, mounting, SOA interpretation, and specification interpretation. Visit www.Cirrus.com for design tools that help automate tasks such as calculations for stability, internal power dissipation, heatsink selection; Apex's complete Application Notes library; Technical Seminar Workbook; and Evaluation Kits.

STABILITY CONSIDERATIONS

All monolithic power op amps use output stage topologies that present special stability problems. This is primarily due to non-complementary (both devices are NPN) output stages with a mismatch in gain and phase response for different polarities of output current. It is difficult for the op amp manufacturer to optimize compensation for all operating conditions.

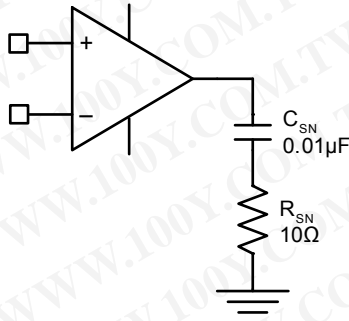

FIGURE 4. R-C Snubber

For applications with load current exceeding 300mA, oscillation may appear. The oscillation may occur only with the output voltage swing at the negative or positive half cycle. Under most operating and load conditions acceptable stability can be achieved by providing a series RC snubber network connected from the output to ground (see Figure 4). The recommended component values of the of the network are, $R_{SN} = 10\Omega$ and $C_{SN} = 0.01\mu F$. Please refer to Application Note 1 for further details.

SAFE OPERATING AREA (SOA)

The SOA curves combine the effect of all limits for this power op amp. For a given application, the direction and magnitude of the output current should be calculated or measured and checked against the SOA curves. This is simple for resistive loads but more complex for reactive and EMF generating loads. The following guidelines may save extensive analytical efforts.

THERMAL CONSIDERATIONS

The PA60EU has a large exposed copper heat tab to which the monolithic is directly attached. The PA60EU may require a thermal washer, which is electrically insulating since the tab is directly tied to -VS. This can result in a thermal impedance RCS of up to 1°C/W or greater.

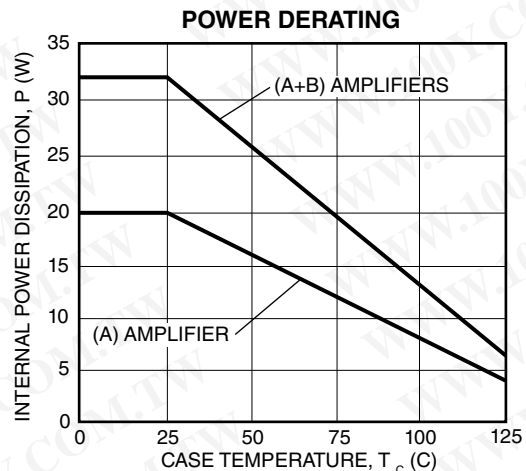
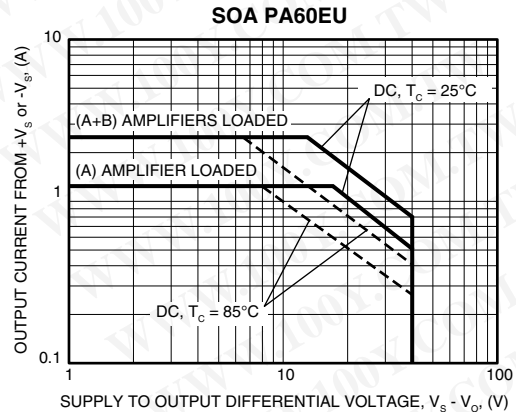

MOUNTING PRECAUTIONS

1. Always use a heat sink. Even unloaded the PA60EU can dissipate up to .4 watts.
2. Avoid bending the leads. Such action can lead to internal damage.
3. Always fasten the tab of the EU package to the heat sink before the leads are soldered to fixed terminals.
4. Strain relief must be provided if there is any probability of axial stress to the leads.