

TO-92



Pin Definition:

1. Source
2. Gate
3. Drain

PRODUCT SUMMARY

V_{DS} (V)	$R_{DS(on)}$ (Ω)	I_D (mA)
60	5 @ $V_{GS} = 10V$	100
	5.5 @ $V_{GS} = 5V$	100

Features

- Low On-Resistance
- ESD Protection
- High Speed Switching
- Low Voltage Drive

Ordering Information

Part No.	Package	Packing
TSM2N7000KCT B0	TO-92	1Kpcs / Bulk
TSM2N7000KCT A3	TO-92	2Kpcs / Ammo

Block Diagram

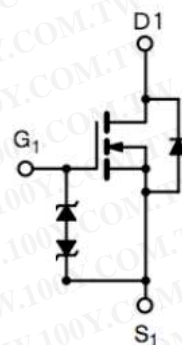

N-Channel MOSFET

Absolute Maximum Rating ($T_a = 25^\circ C$ unless otherwise noted)

Parameter	Symbol	Limit	Unit
Drain-Source Voltage	V_{DS}	60	V
Gate-Source Voltage	V_{GS}	± 20	V
Drain Current	Continuous @ $T_A=25^\circ C$	I_D	300
	Pulsed	I_{DM}	700
Drain Reverse Current	Continuous @ $T_A=25^\circ C$	I_{DR}	300
	Pulsed	I_{DMR}	700
Maximum Power Dissipation	P_D	400	mW
Operating Junction Temperature	T_J	+150	$^\circ C$
Operating Junction and Storage Temperature Range	T_J, T_{STG}	-55 to +150	$^\circ C$

Thermal Performance

Parameter	Symbol	Limit	Unit
Lead Temperature (1/8" from case)	T_L	10	S
Junction to Ambient Thermal Resistance (PCB mounted)	$R\theta_{JA}$	357	$^\circ C/W$

Notes:

- a. Pulse width limited by the Maximum junction temperature
- b. Surface Mounted on FR4 Board, $t \leq 5$ sec.

Electrical Specifications (Ta = 25°C, unless otherwise noted)

Parameter	Conditions	Symbol	Min	Typ	Max	Unit
Static						
Drain-Source Breakdown Voltage	$V_{GS} = 0V, I_D = 10\mu A$	BV_{DSS}	60	--	--	V
Gate Threshold Voltage	$V_{DS} = V_{GS}, I_D = 250\mu A$	$V_{GS(TH)}$	1.0	--	2.5	V
Gate Body Leakage	$V_{GS} = \pm 20V, V_{DS} = 0V$	I_{GSS}	--	--	± 10	μA
Zero Gate Voltage Drain Current	$V_{DS} = 60V, V_{GS} = 0V$	I_{DSS}	--	--	1.0	μA
Drain-Source On-State Resistance	$V_{GS} = 10V, I_D = 100mA$	$R_{DS(ON)}$	--	3	5	Ω
	$V_{GS} = 5V, I_D = 100mA$		--	3.6	5.5	
Forward Transconductance	$V_{DS} = 10V, I_D = 200mA$	g_{fs}	100	--	--	mS
Diode Forward Voltage	$I_S = 300mA, V_{GS} = 0V$	V_{SD}	--	0.9	1.2	V
Dynamic^b						
Total Gate Charge	$V_{DS} = 10V, I_D = 250mA,$ $V_{GS} = 4.5V$	Q_g	--	0.4	--	nC
Input Capacitance	$V_{DS} = 25V, V_{GS} = 0V,$ $f = 1.0MHz$	C_{iss}	--	7.32	--	pF
Output Capacitance		C_{oss}	--	3.42	--	
Reverse Transfer Capacitance		C_{rss}	--	7.63	--	
Switching^c						
Turn-On Delay Time	$V_{DD} = 30V, R_G = 10\Omega$	$t_{d(on)}$	--	25	--	nS
Turn-Off Delay Time	$I_D = 100mA, V_{GEN} = 10V,$	$t_{d(off)}$	--	35	--	

Notes:

- a. pulse test: $PW \leq 300\mu S$, duty cycle $\leq 2\%$
- b. For DESIGN AID ONLY, not subject to production testing.
- b. Switching time is essentially independent of operating temperature.

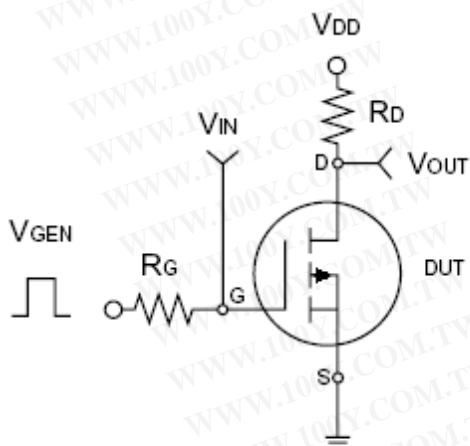

Switching Test Circuit

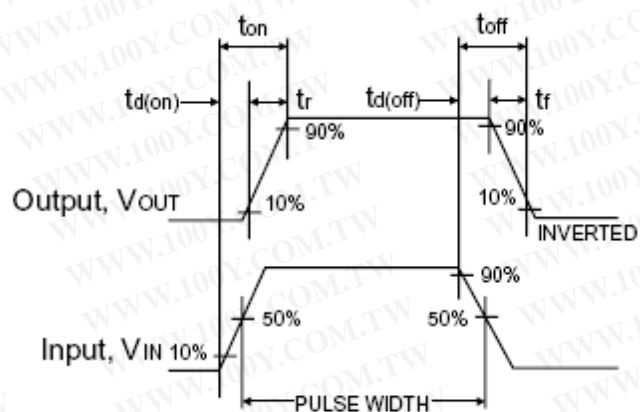

Switchin Waveforms

Electrical Characteristics Curve (Ta = 25°C, unless otherwise noted)

Output Characteristics

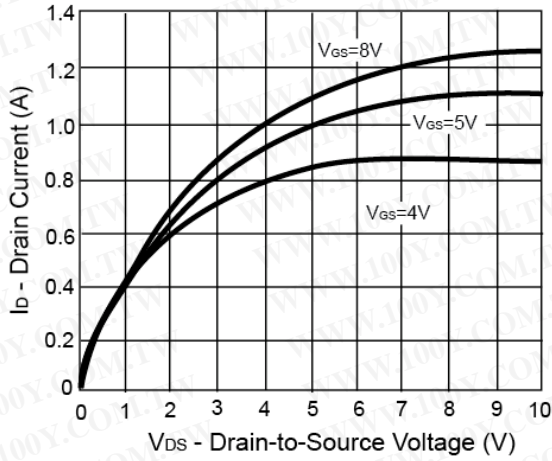

Transfer Characteristics

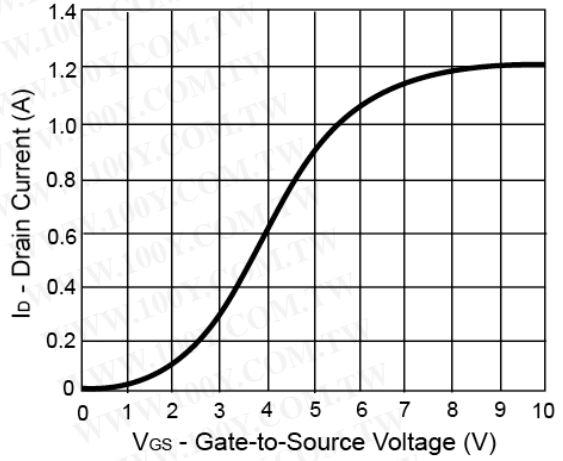

On-Resistance vs. Drain Current

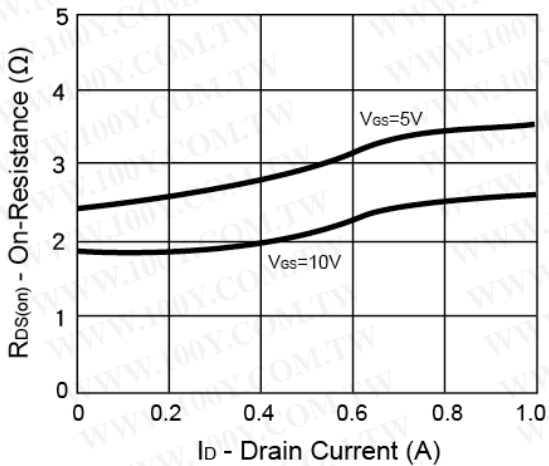

Forward Transfer Admittance vs. Drain Current

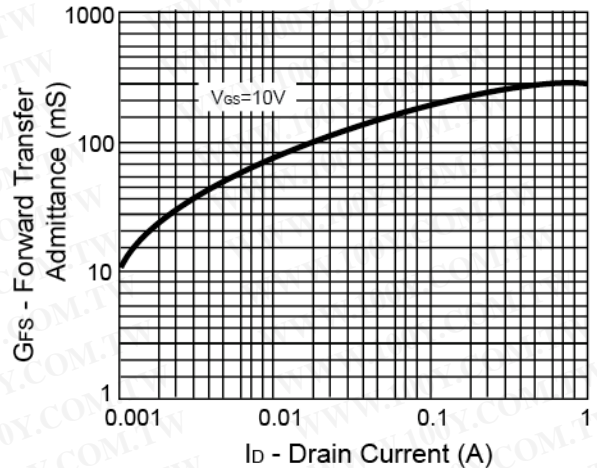

On-Resistance vs. Gate-Source Voltage

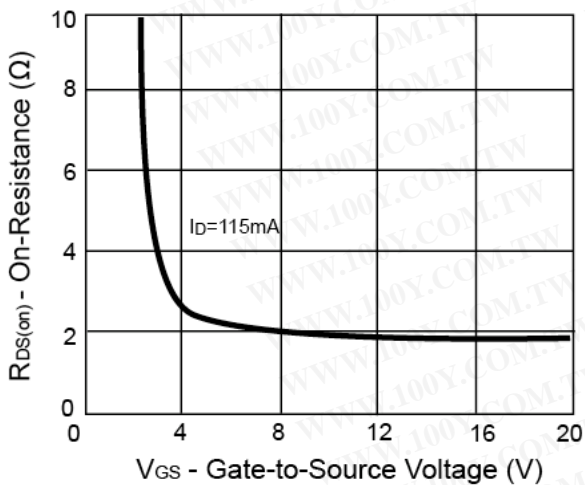

Power Derating Curve

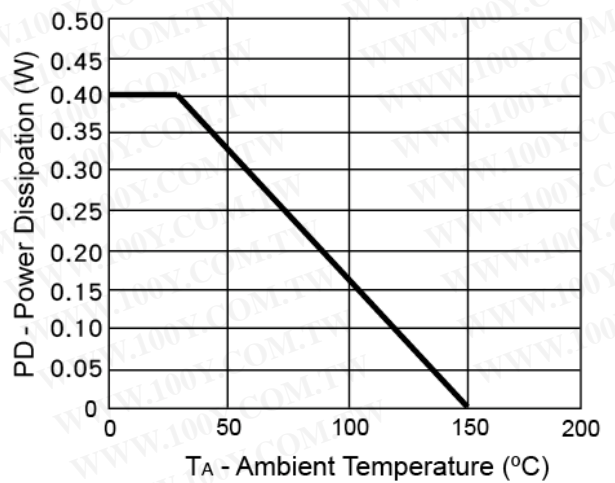

TO-92 Mechanical Drawing

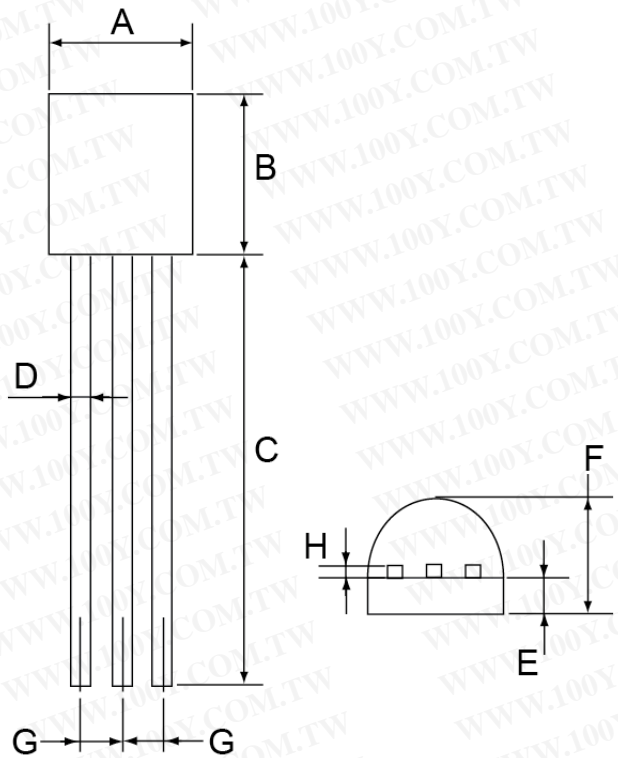

TO-92 DIMENSION				
DIM	MILLIMETERS		INCHES	
	MIN	MAX	MIN	MAX
A	4.30	4.70	0.169	0.185
B	4.30	4.70	0.169	0.185
C	13.53 (typ)		0.532 (typ)	
D	0.39	0.49	0.015	0.019
E	1.18	1.28	0.046	0.050
F	3.30	3.70	0.130	0.146
G	1.27	1.31	0.050	0.051
H	0.33	0.43	0.013	0.017

勝特力材料 886-3-5753170
 勝特力电子(上海) 86-21-34970699
 勝特力电子(深圳) 86-755-83298787
[Http://www.100y.com.tw](http://www.100y.com.tw)

Marking Diagram

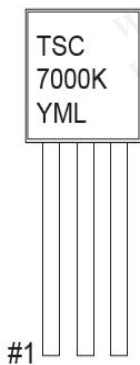

- Y = Year Code
- M = Month Code
- (A=Jan, B=Feb, C=Mar, D=Apr, E=May, F=Jun, G=Jul, H=Aug, I=Sep, J=Oct, K=Nov, L=Dec)
- L = Lot Code

TO-92 Ammo Pack Mechanical Drawing

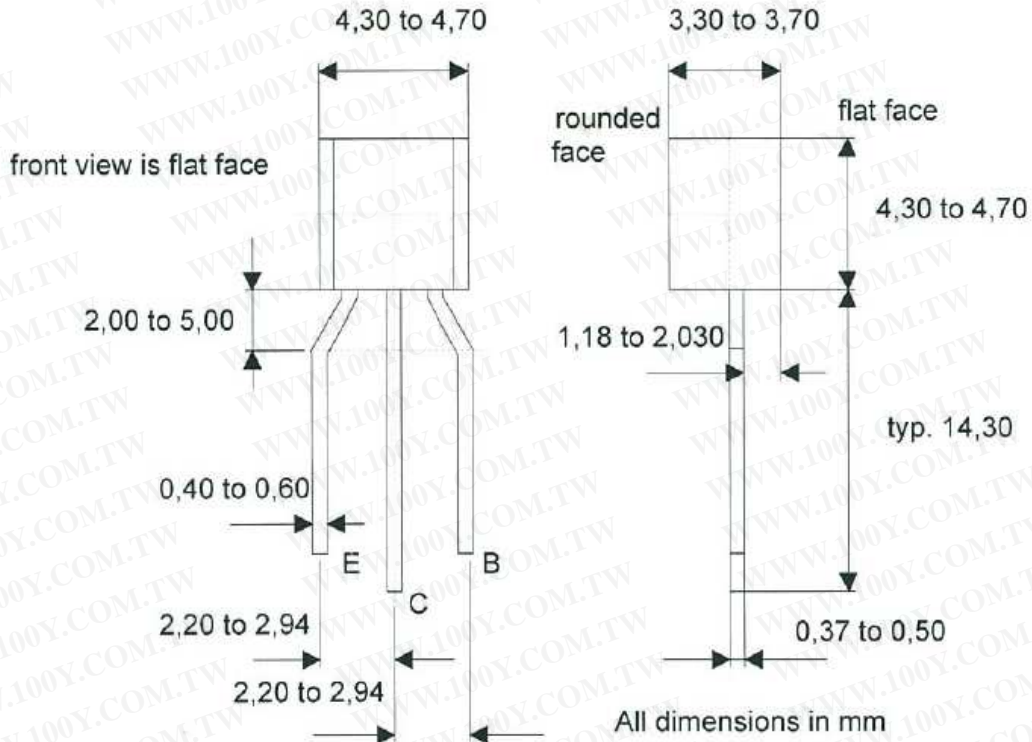

勝特力材料 886-3-5753170
勝特力电子(上海) 86-21-34970699
勝特力电子(深圳) 86-755-83298787
[Http://www.100y.com.tw](http://www.100y.com.tw)

勝特力材料 886-3-5753170
勝特力电子(上海) 86-21-34970699
勝特力电子(深圳) 86-755-83298787
[Http://www.100y.com.tw](http://www.100y.com.tw)

Notice

Specifications of the products displayed herein are subject to change without notice. TSC or anyone on its behalf, assumes no responsibility or liability for any errors or inaccuracies.

Information contained herein is intended to provide a product description only. No license, express or implied, to any intellectual property rights is granted by this document. Except as provided in TSC's terms and conditions of sale for such products, TSC assumes no liability whatsoever, and disclaims any express or implied warranty, relating to sale and/or use of TSC products including liability or warranties relating to fitness for a particular purpose, merchantability, or infringement of any patent, copyright, or other intellectual property right.

The products shown herein are not designed for use in medical, life-saving, or life-sustaining applications. Customers using or selling these products for use in such applications do so at their own risk and agree to fully indemnify TSC for any damages resulting from such improper use or sale.