

NPN-SWITCHING SILICON TRANSISTOR

Qualified per MIL-PRF-19500/251

DEVICES

2N2218	2N2219
2N2218A	2N2219A
2N2218AL	2N2219AL

勝特力材料 886-3-5753170
 勝特力电子(上海) 86-21-34970699
 勝特力电子(深圳) 86-755-83298787
[Http://www.100y.com.tw](http://www.100y.com.tw)

LEVELS

JAN
JANTX
JANTXV
JANS *

* Also available in Radiation Hardened versions. See datasheet for JANSR2N2218 & JANSR2N2219

ABSOLUTE MAXIMUM RATINGS ($T_C = +25^\circ\text{C}$ unless otherwise noted)

Parameters / Test Conditions	Symbol	2N2218 2N2219	2N221A; L 2N2219A; L	Unit
Collector-Emitter Voltage	V_{CEO}	30	50	Vdc
Collector-Base Voltage	V_{CBO}	60	75	Vdc
Emitter-Base Voltage	V_{EBO}	5.0	6.0	Vdc
Collector Current	I_C	800		mA
Total Power Dissipation	P_T	@ $T_A = +25^\circ\text{C}$	0.8	W
		@ $T_C = +25^\circ\text{C}$	3.0	W
Operating & Storage Junction Temp. Range	T_{op}, T_{stg}	-55 to +200		$^\circ\text{C}$

THERMAL CHARACTERISTICS

Parameters / Test Conditions	Symbol	Value	Unit
Thermal Resistance, Junction-to-Case	$R_{\theta JC}$	59	$^\circ\text{C}/\text{W}$

Note: (1) Derate linearly 4.6mW/ $^\circ\text{C}$ above $T_A > +25^\circ\text{C}$
 (2) Derate linearly 17.0mW/ $^\circ\text{C}$ above $T_C > +25^\circ\text{C}$

ELECTRICAL CHARACTERISTICS ($T_A = +25^\circ\text{C}$, unless otherwise noted)

Parameters / Test Conditions	Symbol	Min.	Max.	Unit
OFF CHARACTERISTICS				
Collector-Emitter Breakdown Voltage $I_E = 10\text{mA}$	$V_{(BR)CEO}$	30	50	Vdc
2N2218; 2N2219 2N2218A; 2N2219A / AL				
Emitter-Base Cutoff Current $V_{EB} = 5.0\text{Vdc}$	I_{EBO}		10	μAdc
$V_{EB} = 6.0\text{Vdc}$			10	ηAdc
$V_{EB} = 4.0\text{Vdc}$			10	
Collector-Base Cutoff Current $V_{CE} = 30\text{Vdc}$	I_{CES}		10	ηAdc
$V_{CE} = 50\text{Vdc}$			10	

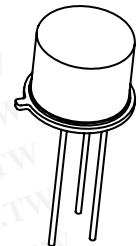

TO-39 (TO-205AD)
 2N2218, 2N2218A
 2N2219, 2N2219A

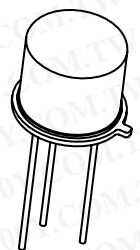

TO-5
 2N2218AL
 2N2219AL

ELECTRICAL CHARACTERISTICS ($T_A = +25^\circ\text{C}$, unless otherwise noted) (Con't)

Parameters / Test Conditions	Symbol	Min.	Max.	Unit
Collector-Base Cutoff Current				
$V_{CB} = 50\text{Vdc}$	2N2218; 2N2219		10	$\eta\text{A dc}$
$V_{CB} = 60\text{Vdc}$	2N2218; 2N2219		10	$\mu\text{A dc}$
$V_{CB} = 60\text{Vdc}$	2N2218A; 2N2219A / AL		10	$\eta\text{A dc}$
$V_{CB} = 75\text{Vdc}$	2N2218A; 2N2219A / AL		10	$\mu\text{A dc}$
ON CHARACTERISTICS (3)				
Forward-Current Transfer Ratio				
$I_C = 0.1\text{mA dc}$, $V_{CE} = 10\text{Vdc}$	2N2218	20		
	2N2219	35		
	2N2218A; 2N2218AL	30		
	2N2219A; 2N2219AL	50		
$I_C = 1.0\text{mA dc}$, $V_{CE} = 10\text{Vdc}$	2N2218	25	150	
	2N2219	50	325	
	2N2218A; 2N2218AL	35	150	
	2N2219A; 2N2219AL	75	325	
$I_C = 10\text{mA dc}$, $V_{CE} = 10\text{Vdc}$	2N2218	35		
	2N2219	75		
	2N2218A; 2N2218AL	40		
	2N2219A; 2N2219AL	100		
$I_C = 150\text{mA dc}$, $V_{CE} = 10\text{Vdc}$	2N2218; A; AL	40	120	
	2N2219; A; AL	100	300	
$I_C = 500\text{mA dc}$, $V_{CE} = 10\text{Vdc}$	2N2218; A; AL	20		
	2N2219; A; AL	30		
Collector-Emitter Saturation Voltage				
$I_C = 150\text{mA dc}$, $I_B = 15\text{mA dc}$	2N2218; 2N2219		0.4	
	2N2218A; 2N2219A / AL		0.3	Vdc
$I_C = 500\text{mA dc}$, $I_B = 50\text{mA dc}$	2N2218; 2N2219		1.6	
	2N2218A; 2N2219A / AL		1.0	
Base-Emitter Saturation Voltage				
$I_C = 150\text{mA dc}$, $I_B = 15\text{mA dc}$	2N2218; 2N2219	0.6	1.3	
	2N2218A; 2N2219A / AL	0.6	1.2	Vdc
$I_C = 500\text{mA dc}$, $I_B = 50\text{mA dc}$	2N2218; 2N2219		2.6	
	2N2218A; 2N2219A / AL		2.0	

DYNAMIC CHARACTERISTICS

Parameters / Test Conditions	Symbol	Min.	Max.	Unit
Magnitude of Small-Signal Forward Current Transfer Ratio $I_C = 20\text{mA}$, $V_{CE} = 20\text{V}$, $f = 100\text{MHz}$	$ h_{fe} $	2.5	12	
Small-Signal Forward Current Transfer Ratio $I_C = 1.0\text{mA}$, $V_{CE} = 10\text{V}$, $f = 1.0\text{kHz}$	h_{fe}	25 50 35 75		
Output Capacitance $V_{CB} = 10\text{V}$, $I_E = 0$, $100\text{kHz} \leq f \leq 1.0\text{MHz}$	C_{obo}		8.0	pF
Input Capacitance $V_{EB} = 0.5\text{V}$, $I_C = 0$, $100\text{kHz} \leq f \leq 1.0\text{MHz}$	C_{ibo}		25	pF

SWITCHING CHARACTERISTICS

Parameters / Test Conditions	Symbol	Min.	Max.	Unit
$V_{CC} = 30\text{V}$, $I_C = 150\text{mA}$, $I_{B1} = 15\text{mA}$				
Turn-On Time (See Figure 3 of MIL-PRF-19500/251)	t_{on}	2N2218, 2N2219 2N2218A, 2N2219A / AL	40 35	ηs
Turn-Off Time (See Figure 4 of MIL-PRF-19500/251)	t_{off}	2N2218, 2N2219 2N2218A, 2N2219A / AL	250 300	ηs

(3) Pulse Test: Pulse Width = $300\mu\text{s}$, Duty Cycle $\leq 2.0\%$.

PACKAGE DIMENSIONS

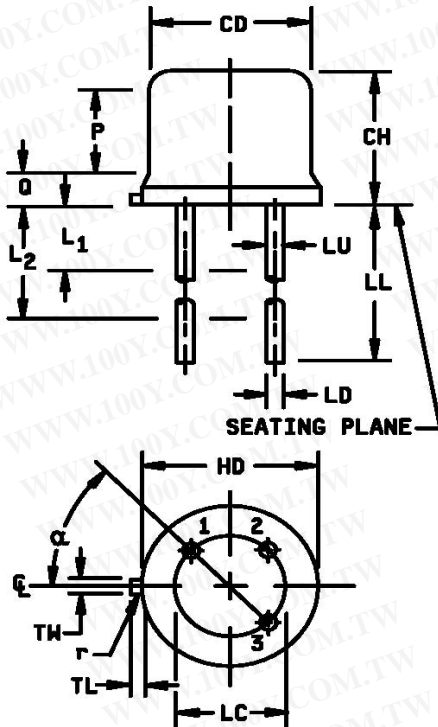

Symbol	Dimensions				Notes
	Inches		Millimeters		
	Min	Max	Min	Max	
CD	.305	.335	7.75	8.51	
CH	.240	.260	6.10	6.60	
HD	.335	.370	8.51	9.40	
LC	.200 TP		5.08 TP		7
LD	.016	.019	0.41	0.48	8, 9
LL	See note 14				
LU	.016	.019	0.41	0.48	8, 9
L ₁		.050		1.27	8, 9
L ₂	.250		6.35		8, 9
P	.100		2.54		7
Q		.030		0.76	5
TL	.029	.045	0.74	1.14	3, 4
TW	.028	.034	0.71	0.86	3
r		.010		0.25	10
α	45° TP		45° TP		7

NOTES:

- Dimensions are in inches.
- Millimeters are given for general information only.
- Beyond r (radius) maximum, TW shall be held for a minimum length of .011 (0.28 mm).
- Dimension TL measured from maximum HD.
- Body contour optional within zone defined by HD, CD, and Q.
- CD shall not vary more than .010 inch (0.25 mm) in zone P. This zone is controlled for automatic handling.
- Leads at gauge plane .054 +.001 -.000 inch (1.37 +0.03 -0.00 mm) below seating plane shall be within .007 inch (0.18 mm) radius of true position (TP) at maximum material condition (MMC) relative to tab at MMC.
- Dimension LU applies between L₁ and L₂. Dimension LD applies between L₂ and LL minimum. Diameter is uncontrolled in L₁ and beyond LL minimum.
- All three leads.
- The collector shall be internally connected to the case.
- Dimension r (radius) applies to both inside corners of tab.
- In accordance with ASME Y14.5M, diameters are equivalent to φx symbology.
- Lead 1 = emitter, lead 2 = base, lead 3 = collector.
- For L suffix devices (TO-5), dimension LL = 1.5 inches (38.10 mm) min. and 1.75 inches (44.45 mm) max. For non-L suffix types (TO-39), dimension LL = .5 inch (12.70 mm) min. and .750 inch (19.05 mm) max.

勝特力材料 886-3-5753170
 勝特力电子(上海) 86-21-34970699
 勝特力电子(深圳) 86-755-83298787
[Http://www.100y.com.tw](http://www.100y.com.tw)

FIGURE 1. Physical dimensions (similar to TO-39, TO-5).