

# Up to 6 GHz Low Noise Silicon Bipolar Transistor

## Technical Data

勝特力材料 886-3-5753170  
 勝特力电子(上海) 86-21-34970699  
 勝特力电子(深圳) 86-755-83298787  
[Http://www.100y.com.tw](http://www.100y.com.tw)

### AT-41486

#### Features

- **Low Noise Figure:**  
1.4 dB Typical at 1.0 GHz  
1.7 dB Typical at 2.0 GHz
- **High Associated Gain:**  
18.0 dB Typical at 1.0 GHz  
13.0 dB Typical at 2.0 GHz
- **High Gain-Bandwidth Product:** 8.0 GHz Typical  $f_T$
- **Surface Mount Plastic Package**
- **Tape-and-Reel Packaging Option Available<sup>[1]</sup>**

**Note:**

1. Refer to "Tape-and-Reel Packaging for Semiconductor Devices".

#### Description

Hewlett-Packard's AT-41486 is a general purpose NPN bipolar transistor that offers excellent high frequency performance. The AT-41486 is housed in a low cost surface mount .085" diameter plastic package. The 4 micron

emitter-to-emitter pitch enables this transistor to be used in many different functions. The 14 emitter finger interdigitated geometry yields an intermediate sized transistor with impedances that are easy to match for low noise and moderate power applications. Applications include use in wireless systems as an LNA, gain stage, buffer, oscillator, and mixer. An optimum noise match near  $50 \Omega$  at 900 MHz, makes this device easy to use as a low noise amplifier.

The AT-41486 bipolar transistor is fabricated using Hewlett-Packard's 10 GHz  $f_T$  Self-Aligned-Transistor (SAT) process. The die is nitride passivated for surface protection. Excellent device uniformity, performance and reliability are produced by the use of ion-implantation, self-alignment techniques, and gold metalization in the fabrication of this device.

#### 86 Plastic Package



#### Pin Connections

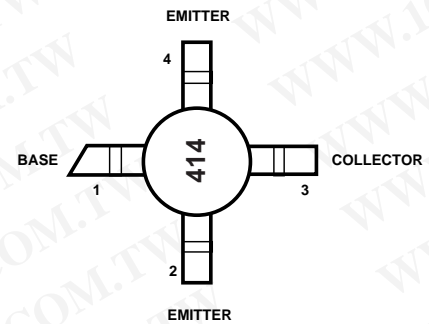

## AT-41486 Absolute Maximum Ratings

Symbol	Parameter	Units	Absolute Maximum <sup>[1]</sup>
V <sub>EBO</sub>	Emitter-Base Voltage	V	1.5
V <sub>CBO</sub>	Collector-Base Voltage	V	20
V <sub>CEO</sub>	Collector-Emitter Voltage	V	12
I <sub>C</sub>	Collector Current	mA	60
P <sub>T</sub>	Power Dissipation <sup>[2,3]</sup>	mW	500
T <sub>j</sub>	Junction Temperature	°C	150
T <sub>STG</sub>	Storage Temperature	°C	-65 to 150

### Thermal Resistance<sup>[2,4]</sup>:

$$\theta_{jc} = 165^{\circ}\text{C/W}$$

#### Notes:

1. Permanent damage may occur if any of these limits are exceeded.
2. T<sub>CASE</sub> = 25°C.
3. Derate at 6 mW/°C for T<sub>C</sub> > 68°C.
4. See MEASUREMENTS section "Thermal Resistance" for more information.

## Part Number Ordering Information

Part Number	Increment	Comments
AT-41486-TR1	1000	Reel
AT-41486-BLK	100	Bulk

**Note:** For more information, see "Tape and Reel Packaging for Semiconductor Devices".

## Electrical Specifications, T<sub>A</sub> = 25°C

Symbol	Parameters and Test Conditions	Units	Min.	Typ.	Max.
S <sub>21E</sub>   <sup>2</sup>	Insertion Power Gain; V <sub>CE</sub> = 8 V, I <sub>C</sub> = 25 mA f = 2.0 GHz f = 4.0 GHz	dB		17.5 11.5	
P <sub>1dB</sub>	Power Output @ 1 dB Gain Compression V <sub>CE</sub> = 8 V, I <sub>C</sub> = 25 mA	dBm		18.0	
G <sub>1dB</sub>	1 dB Compressed Gain; V <sub>CE</sub> = 8 V, I <sub>C</sub> = 25 mA	dB		13.5	
NF <sub>O</sub>	Optimum Noise Figure: V <sub>CE</sub> = 8 V, I <sub>C</sub> = 10 mA f = 1.0 GHz f = 2.0 GHz f = 4.0 GHz	dB		1.4 1.7 3.0	1.8
G <sub>A</sub>	Gain @ NFO; V <sub>CE</sub> = 8 V, I <sub>C</sub> = 10 mA f = 1.0 GHz f = 2.0 GHz f = 4.0 GHz	dB	17.0	18.0 13.0 9.0	
f <sub>T</sub>	Gain Bandwidth Product: V <sub>CE</sub> = 8 V, I <sub>C</sub> = 25 mA	GHz		8.0	
h <sub>FE</sub>	Forward Current Transfer Ratio; V <sub>CE</sub> = 8 V, I <sub>C</sub> = 10 mA	—	30	150	270
I <sub>CBO</sub>	Collector Cutoff Current; V <sub>CB</sub> = 8 V	μA			0.2
I <sub>EBO</sub>	Emitter Cutoff Current; V <sub>EB</sub> = 1 V	μA			1.0
C <sub>CB</sub>	Collector Base Capacitance <sup>[1]</sup> ; V <sub>CB</sub> = 8 V, f = 1 MHz	pF		0.25	

#### Note:

1. For this test, the emitter is grounded.

**AT-41486 Typical Performance,  $T_A = 25^\circ\text{C}$**

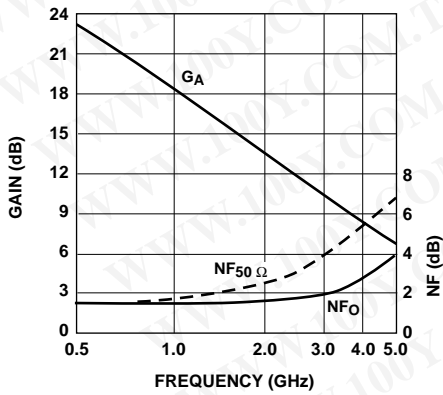

**Figure 1. Noise Figure and Associated Gain vs. Frequency.**  
 $V_{CE} = 8\text{ V}$ ,  $I_C = 10\text{ mA}$ .

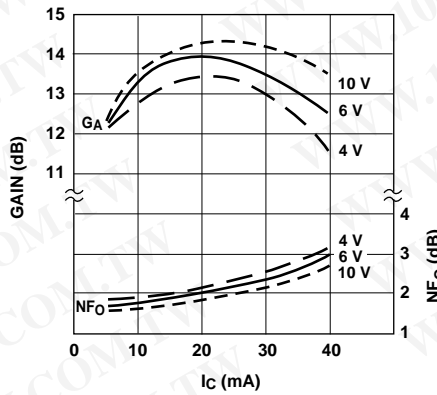

**Figure 2. Optimum Noise Figure and Associated Gain vs. Collector Current and Collector Voltage.**  $f = 2.0\text{ GHz}$ .

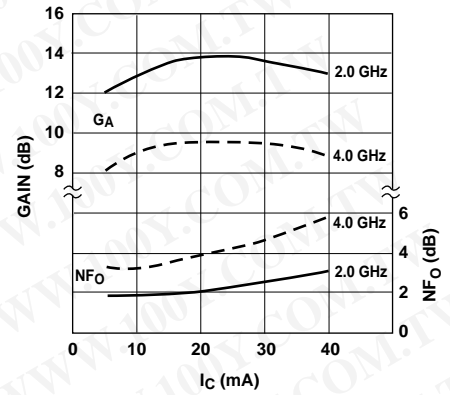

**Figure 3. Optimum Noise Figure and Associated Gain vs. Collector Current and Frequency.**  $V_{CE} = 8\text{ V}$ .

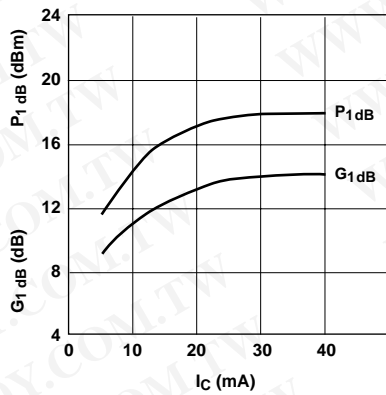

**Figure 4. Output Power and 1 dB Compressed Gain vs. Collector Current and Frequency.**  $V_{CE} = 8\text{ V}$ ,  $f = 2.0\text{ GHz}$ .

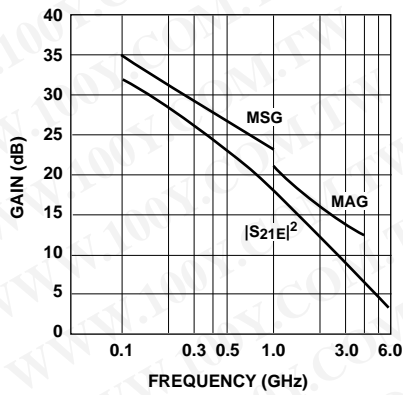

**Figure 5. Insertion Power Gain, Maximum Available Gain and Maximum Stable Gain vs. Frequency.**  
 $V_{CE} = 8\text{ V}$ ,  $I_C = 25\text{ mA}$ .

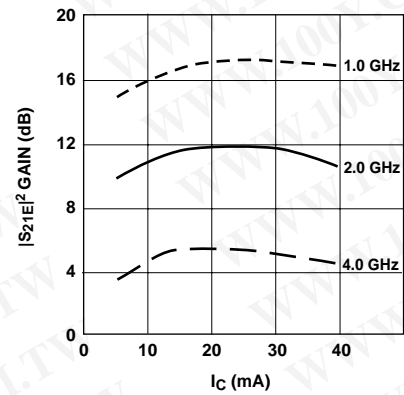

**Figure 6. Insertion Power Gain vs. Collector Current and Frequency.**  
 $V_{CE} = 8\text{ V}$ .

**AT-41486 Typical Scattering Parameters, Common Emitter,**

$Z_O = 50\ \Omega$ ,  $T_A = 25^\circ\text{C}$ ,  $V_{CE} = 8\ \text{V}$ ,  $I_C = 10\ \text{mA}$

Freq. GHz	$S_{11}$		dB	$S_{21}$		dB	$S_{12}$		$S_{22}$	
	Mag.	Ang.		Mag.	Ang.		Mag.	Ang.	Mag.	Ang.
0.1	.74	-38	28.1	25.46	157	-39.6	.011	68	.94	-12
0.5	.59	-127	22.0	12.63	107	-30.2	.031	47	.60	-29
1.0	.56	-168	16.8	6.92	84	-27.7	.041	46	.49	-29
1.5	.57	169	13.5	4.72	69	-26.2	.049	49	.45	-32
2.0	.62	152	11.1	3.61	56	-24.8	.058	43	.42	-39
2.5	.63	142	9.3	2.91	47	-23.4	.068	52	.40	-42
3.0	.64	130	7.6	2.41	37	-22.2	.078	52	.39	-50
3.5	.68	122	6.3	2.06	26	-20.6	.093	51	.37	-60
4.0	.71	113	5.1	1.80	16	-19.5	.106	48	.35	-70
4.5	.74	105	4.0	1.59	7	-18.0	.125	48	.35	-84
5.0	.77	99	3.1	1.42	-4	-17.2	.139	43	.35	-98
5.5	.79	93	2.0	1.27	-13	-16.3	.153	38	.35	-114
6.0	.81	87	1.1	1.13	-22	-15.4	.170	34	.35	-131

**AT-41486 Typical Scattering Parameters,**

Common Emitter,  $Z_O = 50\ \Omega$ ,  $T_A = 25^\circ\text{C}$ ,  $V_{CE} = 8\ \text{V}$ ,  $I_C = 25\ \text{mA}$

Freq. GHz	$S_{11}$		dB	$S_{21}$		dB	$S_{12}$		$S_{22}$	
	Mag.	Ang.		Mag.	Ang.		Mag.	Ang.	Mag.	Ang.
0.1	.50	-75	32.0	40.01	142	-41.3	.009	54	.85	-17
0.5	.55	-158	23.2	14.38	97	-34.1	.020	48	.51	-24
1.0	.57	177	17.5	7.50	78	-29.9	.032	61	.46	-24
1.5	.57	161	14.1	5.07	65	-27.3	.043	62	.44	-28
2.0	.59	148	11.5	3.75	53	-24.8	.058	59	.43	-35
2.5	.61	139	9.6	3.02	45	-22.9	.072	58	.40	-41
3.0	.65	128	8.0	2.52	34	-21.6	.083	57	.38	-49
3.5	.70	121	6.7	2.17	24	-20.1	.099	56	.36	-59
4.0	.74	113	5.7	1.92	14	-18.8	.115	52	.34	-72
4.5	.78	107	4.7	1.72	3	-17.6	.132	47	.32	-87
5.0	.78	102	3.7	1.53	-8	-16.6	.149	42	.31	-106
5.5	.78	96	2.7	1.36	-19	-15.4	.169	36	.31	-125
6.0	.76	91	1.6	1.21	-29	-14.5	.188	31	.33	-144

A model for this device is available in the DEVICE MODELS section.

**AT-41486 Noise Parameters:  $V_{CE} = 8\ \text{V}$ ,  $I_C = 10\ \text{mA}$**

Freq. GHz	$NF_0$ dB	$\Gamma_{opt}$		$R_N/50$
		Mag	Ang	
0.1	1.3	.12	3	0.17
0.5	1.3	.10	16	0.17
1.0	1.4	.04	43	0.16
2.0	1.7	.12	-145	0.16
4.0	3.0	.44	-99	0.40

## 86 Plastic Package Dimensions

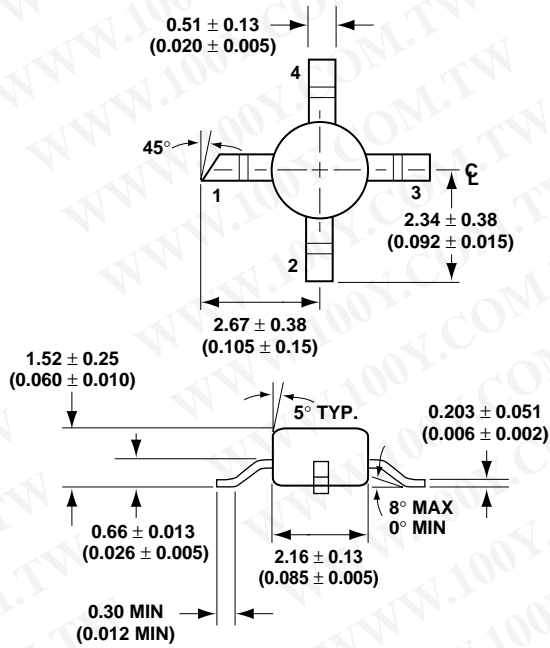

DIMENSIONS ARE IN MILLIMETERS (INCHES)

This datasheet has been download from:

[www.datasheetcatalog.com](http://www.datasheetcatalog.com)

Datasheets for electronics components.